

AGENDA
 IRVINE RANCH WATER DISTRICT
 SUPPLY RELIABILITY PROGRAMS COMMITTEE
 THURSDAY, MARCH 21, 2024

This meeting will be held in-person at the District’s headquarters located at 15600 Sand Canyon Avenue, Irvine, California. The meeting will be held in the second floor SC Committee room. The meeting will also be broadcasted via Webex for those wanting to observe the meeting virtually.

To observe this meeting virtually, please join online using the link and information below:

Via Web: <https://irwd.webex.com/irwd/j.php?MTID=m4fd1880315c0b5f8b2e94d9c93122f9d>
 Meeting Number (Access Code): 2489 978 3480
 Meeting Password: M3RacpmX3b3

As courtesy to the other participants, please mute your device when you are not speaking.

PLEASE NOTE: Participants joining the meeting will be placed into the Webex lobby when (if) the Committee enters Closed Session. Participants who remain in the “lobby” will automatically be returned to the open session of the Committee once the closed session has concluded. Participants who join the meeting while the Committee is in closed session will receive a notice that the meeting has been locked. They will be able to join the meeting once the Closed Session has concluded.

CALL TO ORDER 1:30 p.m.

ATTENDANCE Committee Chair: Doug Reinhart _____
 Committee Member: Peer Swan _____

ALSO PRESENT

Paul Cook	_____	Paul Weghorst	_____
Neveen Adly	_____	Fiona Sanchez	_____
Kent Morris	_____	Kellie Welch	_____
Natalie Palacio	_____	Robert Huang	_____
Marina Lindsay	_____	_____	_____
_____	_____	_____	_____

PUBLIC COMMENT NOTICE

If you wish to address the Committee on any item, please submit a request to speak via the “chat” feature available when joining the meeting virtually. Remarks are limited to three minutes per speaker on each subject. Public comments are limited to three minutes per speaker on each subject. You may also submit a public comment in advance of the meeting by emailing comments@irwd.com before 5:00 p.m. on March 20, 2024.

COMMUNICATIONS

1. Notes: Weghorst
2. Public Comments
3. Determine the need to discuss and/or take action on item(s) introduced that came to the attention of the District subsequent to the agenda being posted.
4. Determine which items may be approved without discussion.

INFORMATION

5. WATER BANKING PROJECT FACILITIES, CAPACITIES, OPERATIONS AND PROGRAMS – PALACIO / WELCH / SANCHEZ / WEGHORST

Recommendation: Receive and file.

6. UPDATE ON IRWD AGRICULTURAL LAND LEASES – PALACIO / WELCH / SANCHEZ / WEGHORST

Recommendation: Receive and file.

OTHER BUSINESS

7. Receive Oral Updates from District’s liaison to Dudley Ridge Water District and provide information on relevant activities.
8. Directors’ Comments
9. Adjourn

Availability of agenda materials: Agenda exhibits and other writings that are disclosable public records distributed to all or a majority of the members of the above-named Committee in connection with a matter subject to discussion or consideration at an open meeting of the Committee are available for public inspection in the District’s office, 15600 Sand Canyon Avenue, Irvine, California (“District Office”). If such writings are distributed to members of the Committee less than 72 hours prior to the meeting, they will be available from the District Secretary of the District Office at the same time as they are distributed to Committee Members, except that if such writings are distributed one hour prior to, or during, the meeting, they will be available electronically via the Webex meeting noted. Upon request, the District will provide for written agenda materials in appropriate alternative formats, and reasonable disability-related modification or accommodation to enable individuals with disabilities to participate in and provide comments at public meetings. Please submit a request, including your name, phone number and/or email address, and a description of the modification, accommodation, or alternative format requested at least two days before the meeting. Requests should be emailed to comments@irwd.com. Requests made by mail must be received at least two days before the meeting. Requests will be granted whenever possible and resolved in favor of accessibility.

March 21, 2024

Prepared by: N. Palacio / K. Welch

Submitted by: F. Sanchez / P. Weghorst

Approved by: Paul A. Cook



SUPPLY RELIABILITY PROGRAMS COMMITTEE

WATER BANKING PROJECT FACILITIES, CAPACITIES, OPERATIONS, AND PROGRAMS

SUMMARY:

Staff has prepared information related to IRWD's water banking facilities, capacities, operations, and exchange programs. The information is regularly updated to reflect changes in the status of IRWD's projects, programs, and operations. At the Committee meeting, staff will review this information and provide information on IRWD's forecasted monthly recharge operations for 2024.

BACKGROUND:

Staff has prepared reference materials in tabular, map, and schematic formats to describe IRWD's water banking facilities, capacities, operations, storage, and exchange programs. These reference materials are updated regularly to reflect changes in the status of the projects, programs, and operations. The following is an overview of the reference materials as well as forecasted recharge operations for calendar year 2024 at the IRWD Water Bank.

Capacity and Operations Tables:

A table presenting storage, recharge, and recovery capacities of existing and planned IRWD water banking projects, including capacities available to IRWD in the Kern Water Bank (KWB), is provided as Exhibit "A". Exhibits "B" and "C" provide an update on water banking recovery and recharge operations as well as the balance of the water stored in the Kern Water Bank. Exhibit "B" provides before-loss estimates of water recharged and in storage at the water banking projects, and Exhibit "C" provides after-loss estimates of water recharged and in storage at the projects. There are no changes to Exhibits "B" and "C" from last month.

Summary of Programs:

A table summarizing IRWD's water purchase and exchange programs is presented as Exhibit "D". This table lists each water purchase and exchange program IRWD has entered into and presents information related to the type of exchange, year executed, agreement type, and water type. IRWD and partner shares are listed, and the table shows the total amount of water included in each program. The balances listed for IRWD, and its partners show the amount of water remaining in storage, with IRWD's balances specifying whether the water is stored in Metropolitan Water District's system, Kern County, or owed to IRWD by Dudley Ridge. The table also provides details related to the exportability of IRWD's supplies. There are no changes to Exhibit "D" from last month.

Exhibit “E” graphically depicts how storage of SWP and non-SWP water has changed annually in the Strand and Stockdale Integrated Banking Projects. Exhibit “E” also depicts the balance of water owed to IRWD by Dudley Ridge. The table provided as Exhibit “F” shows how capacities in the water banking projects have been dedicated to IRWD’s existing and proposed exchange programs.

Project Maps:

To support the tables and figures provided as Exhibits “A”, “B”, “C”, “D”, “E”, and “F”, staff has prepared maps depicting project wells, pipelines, recharge basins, and Cross Valley Canal turnout locations, along with the most current recharge rates. These maps are provided as Exhibits “G”, “H”, and “I”, respectively. Exhibit “I” includes current estimated recharge rates at the IRWD Water Bank. The facilities shown on the maps are associated with the Strand Ranch, Stockdale West, Stockdale East, and Drought Relief Projects.

Program Agreement Diagrams:

Schematic diagrams have been prepared that depict IRWD water banking and exchange programs with Rosedale-Rio Bravo Water Storage District, Buena Vista Water Storage District, Dudley Ridge, Metropolitan, and Antelope Valley-East Kern Water Agency (AVEK). These diagrams are provided as Exhibits “J”, “K”, “L”, “M”, “N”, “O”, and “P” as described in the List of Exhibits.

Cost of Water Table:

A table presenting a summary of the costs of water from each of IRWD’s unbalanced exchange partnerships through the year 2021 is provided as Exhibit “Q”. The table lists each of IRWD’s unbalanced exchange partnerships and presents information related to the period over which water was acquired, water type, IRWD’s share of water, and various cost components as well as the total cost of water delivered to IRWD’s service area. Cost components include fixed and variable operating costs, estimated future IRWD recovery costs, the 2024 Metropolitan Full Service Untreated Tier-1 Rate, and a capital cost of water. The variable costs include an administrative fee issued by the Kern County Water Agency for staff time related to processing Transaction Request Forms. The costs of water are presented on a dollar per acre-foot basis. Exhibit “Q” will be updated to reflect 2022 and 2023 operations once all invoices have been received from Rosedale-Rio Bravo Water District.

IRWD’s Coordinated Agreement with Metropolitan:

An overview of IRWD’s Coordinated Operating, Water Storage, Exchange, and Delivery Agreement with Metropolitan and Municipal Water District of Orange County (Coordinated Agreement) is provided as Exhibit “R”. The benefits to IRWD are foundational to the success of IRWD’s water banking project and programs.

Forecasted 2024 Water Recharge Activities:

Projected deliveries to IRWD's Water Bank in 2024 are depicted in Exhibit "S". These projections reflect the current 15% SWP allocation, which does not factor in the February and early March storms. Staff will update the forecasted delivery amounts shown in Exhibit "S" as more information becomes available. Anticipated water bank deliveries in 2024 are as follows:

- AVEK Unbalanced Exchange Program: Early this year AVEK informed staff that it may deliver up to 13,000 AF of SWP Table A water to the IRWD Water Bank but has not provided any further information. Deliveries from AVEK have been removed from Exhibit "S" until further communication has been received from AVEK.
- Homer Capacity Exchange Program: In 2023, IRWD recharged approximately 1,800 AF of water into storage at the IRWD Water Bank using Homer's Cross Valley Canal capacity. Consistent with the terms of the Pilot Capacity Exchange Program, Homer can use recharge capacity at the IRWD Water Bank to recharge an equal amount of its supplies in 2024.
- Silvertip Unbalanced Exchange Program: Staff estimates that Silvertip may deliver up to 4,000 AF of SWP supplies to the IRWD Water Bank in 2024. The preparation of the necessary DWR agreement and securing the approval of Metropolitan and the Kern County Water Agency could require up to five months to finalize.
- Santa Clara Valley Water District Unbalanced Exchange Program: Santa Clara Valley Water District informed staff that it expects to have up to 20,000 AF of SWP Table A Water available for delivery to the IRWD Water Bank in 2024. Staff anticipates that the necessary DWR agreements and approvals may be secured by May allowing deliveries to begin at that time.
- IRWD's SWP Table A Allocation: Last month, DWR announced an increase in the 2024 SWP Table A allocation from 10% to 15%. Because this increase did not consider the February and early March storms, the allocation amount is expected to increase again. Staff anticipates that IRWD will take delivery of its Table A water from Dudley Ridge once the allocation amount has been finalized later in the year.

At the meeting, staff will update the Committee on water supply conditions for the Colorado River, SWP, Central Valley Project, and Kern River systems; staff will also provide an update on landowner matters at the Dudley Ridge Water District.

FISCAL IMPACTS:

None.

ENVIRONMENTAL COMPLIANCE:

Not applicable.

RECOMMENDATION:

Receive and file.

LIST OF EXHIBITS:

- Exhibit “A” – Recharge, Storage and Recovery Capacities of Current and Anticipated Water Banking Projects
- Exhibit “B” – Water Banking Storage, Recharge, and Recovery Operations before Losses
- Exhibit “C” – Water Banking Storage, Recharge, and Recovery Operations after Losses
- Exhibit “D” – Status of IRWD Purchase and Exchange Programs
- Exhibit “E” – Historic Water Storage in Strand and Stockdale Projects
- Exhibit “F” – Dedicated Capacities of Current Water Banking Projects
- Exhibit “G” – Map of Water Banking Project Wells and Pipelines
- Exhibit “H” – Map of Water Banking Recharge Basins and Turnout Facilities
- Exhibit “I” – Map of Water Banking Recharge Rates
- Exhibit “J” – Diagram of IRWD-Rosedale Water Banking and Exchange Program Agreements
- Exhibit “K” – Diagram of Long-term Water Exchange Program with Buena Vista Water Storage District and Diagram of One-year Program to Augment Recharge Using Stockdale West Recharge Facilities with Buena Vista Water Storage District
- Exhibit “L” – Diagram of Unbalanced Exchange Program Diagram with Dudley Ridge
- Exhibit “M” – Diagram of Coordinated Operating, Water Storage, Exchange, and Delivery Agreement with Metropolitan
- Exhibit “N” – Diagram of Template Wheeling Agreement with Metropolitan
- Exhibit “O” – Diagram of Dudley Ridge One-for-One Exchange
- Exhibit “P” – Diagram of Long-term Water Exchange Program with Antelope Valley-East Kern
- Exhibit “Q” – Cost of Water Tables
- Exhibit “R” – Summary of IRWD’s Coordinated Operating, Water Storage, Exchange and Delivery Agreement with Metropolitan and MWDOC (updated 8 Feb 2024)
- Exhibit “S” – Actual and Forecasted 2024 Recharge Operations

Exhibit "A"

TABLE 1
Current and Anticipated Water Banking Projects
Recharge, Storage and Recovery Capacities
 March 21, 2024

WATER BANKING PROJECT	OWNERSHIP AND WELL INFO		ALLOCATED CAPACITY (AF)					1 ST PRIORITY RECOVERY CONDITIONS (CFS)		2 ND PRIORITY RECOVERY CONDITIONS (CFS)	
	IRWD OWNED	WELLS EXISTING	TOTAL STORAGE CAPACITY	ANNUAL RECHARGE 1 ST PRIORITY	ANNUAL RECHARGE 2 ND PRIORITY	ANNUAL RECOVERY 1 ST PRIORITY	ANNUAL RECOVERY 2 ND PRIORITY	RECOVERY CAPACITY AS PLANNED ¹	RECOVERY CAPACITY (Average Daily Production 1/1/2021 - 7/31/2022)	RECOVERY CAPACITY AS PLANNED	RECOVERY CAPACITY CURRENT CONDITIONS
Strand Ranch	Yes	7	50,000	17,500	-	17,500	-	40.0	20.5	-	-
Stockdale West	Yes	3	26,000	27,100	-	11,250	-	15.0	11.6	-	-
Stockdale East	No	2	-	-	19,000	-	7,500	-	-	10.0	9.0
IRWD Acquired Storage Account ²	No	-	50,000	-	-	-	-	-	-	-	-
Drought Relief Project Wells ²	No	3	-	-	-	-	-	15.0	16.5	-	-
Kern Water Bank Storage Account ⁴	No	-	9,495	3,200	-	1,520	<5,000	-	-	-	-
TOTALS		15	135,495	47,800	19,000	30,270	12,500	70.0	48.6	10.0	9.0
Partner Capacities ³			38,000	22,300	9,500	10,850	0	35.5	25.0	-	-
IRWD Capacities (does not include Kern Water Bank capacities)			88,000	22,300	9,500	17,900	7,500	34.5	25.0	-	-
IRWD's recovery <i>during</i> 6 month partner recovery period (AF)								12,420	9,000	-	-
IRWD's recovery <i>after</i> 6 month partner recovery period (AF)								5,480	6,733	-	-
TOTALS (AF)								17,900	15,733	-	-
Number of months needed to recover IRWD's total AF after partners' recovery (Assumes IRWD has use of total recovery capacity after partners' recovery)								8.6	10.2	-	-
Strand Ranch monthly recharge amount assuming 0.3 ft/day average recharge rate (AF)										4,518	
Stockdale West monthly recharge amount assuming 0.3 ft/day average recharge rate (AF)										2,331	
¹ Based on designed Strand recovery capacity assuming 370' bgs. Assumes 5 cfs for each of the Stockdale West and Drought Relief wells in order to meet IRWD's Water Banking, Transfers, and Wheeling policy position. Assumes partners' water is recovered over 6 months. ² IRWD has use of Acquired Storage and Drought Relief Project wells until January 12, 2039, unless the term of the agreement is extended. ³ One half of storage capacity at Stockdale West and Strand Ranch will be allocated for partners. ⁴ Kern Water Bank capacities based on 6.58% of Dudley Ridge Water District's 9.62% share of the Kern Water Bank. Annual recharge amount is based on an average of recharge rates for high and low groundwater level conditions. 5,000 AF of recovery capacity may be available for second priority use.											

Note: This page is intentionally left blank.

Exhibit "B"

TABLE 2
IRWD's Water Banking Storage, Recharge and Recovery Operations - BEFORE LOSSES
 March 21, 2024

TRANSACTIONS	WATER BANKING ENTITY							TOTAL BY WATER TYPE AND STORAGE LOCATION
	IRWD		BUENA VISTA (BVWSD)	CENTRAL COAST (CCWA)	ANTELOPE VALLEY-EAST KERN (AVEK)	VALLEY WATER	DUDLEY RIDGE WATER DISTRICT (DRWD) ³	
	SWP ¹	NON-SWP ²	NON-SWP	SWP	SWP	SWP	SWP	
BEGINNING WATER IN STORAGE 2023 (AF)								
Total Kern Water Bank ⁴	-	3,751	-	-	-	-	-	3,751
Total MWD System	12,033	-	-	-	-	-	43	12,076
Total Kern County	1,383	9,641	225	-	-	-	-	11,249
Total DRWD 1-for-1 Long Term Exchange Credit ⁵	16,500	-	-	-	-	-	-	16,500
TOTAL STORED WATER (1/1/2023)	29,916	13,392	225	-	-	-	43	43,576
(RECOVERY) AND RECHARGE IN 2023 (AF)								
KWB Recovery for use on Jackson Ranch ⁶	-	(232)	-	-	-	-	-	(232)
KWB Deliveries ⁷	-	803	-	-	-	-	-	803
2023 SWP Allocation (100%) Est.	875	-	-	-	-	-	874	1,749
2020 Reserve Water	13	-	-	-	-	-	-	13
BV Long Term Program Kern River Water Est.	-	8,750	8,750	-	-	-	-	17,500
BV 2023 Recharge Kern River Water Est.	-	2,250	2,250	-	-	-	-	4,500
CCWA 2023 Short Term Exchange Est.	225	-	-	225	-	-	-	450
AVEK Long Term Exchange Est.	3,425	-	-	-	3,424	-	-	6,849
DRWD 1-for-1 Long Term Exchange (Recharge) Est.	9,358	-	-	-	-	-	-	9,358
TOTAL 2023 TRANSACTIONS	13,896	11,571	11,000	225	3,424	-	874	40,990
Total Kern Water Bank ⁴	-	4,322	-	-	-	-	-	4,322
Total MWD System	12,033	-	-	-	-	-	43	12,076
Total Kern County	15,279	20,641	11,225	225	3,424	-	874	51,668
Total DRWD 1-for-1 Long Term Exchange Credit ⁵	7,142	-	-	-	-	-	-	7,142
TOTAL STORED WATER (1/1/2024)	34,454	24,963	11,225	225	3,424	-	917	71,784
(RECOVERY) AND RECHARGE IN 2024 (AF)								
KWB Recovery for use on Jackson Ranch ⁶ Est.	-	-	-	-	-	-	-	-
2024 SWP Allocation (15%)	-	-	-	-	-	-	-	-
BV Long Term Program Kern River Water Est.	-	-	-	-	-	-	-	-
AVEK Long Term Exchange Est.	-	-	-	-	-	-	-	-
Silver Tip 2023 Short Term Exchange	-	-	-	-	-	-	-	-
DRWD 1-for-1 Long Term Exchange (Recharge) Est.	2,200	-	-	-	-	-	-	2,200
TOTAL ESTIMATED 2024 TRANSACTIONS	2,200	-	-	-	-	-	-	2,200
ESTIMATED WATER IN STORAGE 2024 (AF)								
Total Kern Water Bank ⁴	-	4,322	-	-	-	-	-	4,322
Total MWD System	12,033	-	-	-	-	-	43	12,076
Total Kern County	17,479	20,641	11,225	225	3,424	-	874	53,868
Total DRWD 1-for-1 Long Term Exchange Credit ⁵	4,942	-	-	-	-	-	-	4,942
TOTAL ESTIMATED STORED WATER TO DATE	34,454	24,963	11,225	225	3,424	-	917	75,208

NOTES: MWD = Metropolitan Water District of Southern California.

¹ IRWD's SWP includes 295 AF from CVWD that stays in Kern County.

² IRWD's Non-SWP total includes 2,403 AF, net of losses, of Kern County Water Agency Article 21 Water.

³ DRWD water supply will be returned by MWD or IRWD's Strand Ranch to IRWD's Jackson Ranch. MWD took delivery of IRWD's 2022 SWP allocation in June 2022.

⁴ IRWD's KWB Account balance includes SWP, Friant and Kern River water. The KWB account balance is included in the Non-SWP column because it is not exportable to IRWD's service area.

⁵ Per the DRWD Long-Term 1-for-1 Exchange Program, Non-SWP water delivered to DRWD landowners will be returned to IRWD as SWP water at a later date. To account for the SWP water that will be returned at a later date, the amount of water owed will be shown as a credit. Total assumes all water is returned to IRWD Water Bank which adds in a 10% loss factor.

⁶ Water recovered from IRWD's Kern Water Bank account for use on Jackson Ranch.

⁷ A portion of IRWD's 2023 SWP deliveries from DRWD include 803 AF of Article 21 water, which was delivered to the Kern Water Bank.

Note: This page is intentionally left blank.

Exhibit "C"

TABLE 3
IRWD's Water Banking Storage, Recharge and Recovery Operations - AFTER LOSSES
 March 21, 2024

TRANSACTIONS	WATER BANKING ENTITY							TOTAL BY WATER TYPE AND STORAGE LOCATION
	IRWD		BUENA VISTA (BVWSD)	CENTRAL COAST (CCWA)	ANTELOPE VALLEY-EAST KERN (AVEK)	VALLEY WATER	DUDLEY RIDGE WATER DISTRICT (DRWD) ³	
	SWP ¹	NON-SWP ²	NON-SWP	SWP	SWP	SWP	SWP	
BEGINNING WATER IN STORAGE 2023 (AF)								
Total Kern Water Bank ⁴	-	3,751	-	-	-	-	-	3,751
Total MWD System	12,033	-	-	-	-	-	43	12,076
Total Kern County	344	5,705	225	-	-	-	-	6,274
Total DRWD 1-for-1 Long Term Exchange Credit ⁵	15,000	-	-	-	-	-	-	15,000
TOTAL STORED WATER (1/1/2023)	27,377	9,456	225	-	-	-	43	37,101
(RECOVERY) AND RECHARGE IN 2023 (AF)								
KWB Recovery for use on Jackson Ranch ⁶	-	(232)	-	-	-	-	-	(232)
KWB Deliveries ⁷	-	723	-	-	-	-	-	723
2023 SWP Allocation (100%) Est.	750	-	-	-	-	-	749	1,499
2020 Reserve Water	12	-	-	-	-	-	-	12
BV Long Term Program Kern River Water Est.	-	7,501	7,896	-	-	-	-	15,397
BV 2023 Recharge Kern River Water Est.	-	1,929	2,030	-	-	-	-	3,959
CCWA 2023 Short Term Exchange Est.	193	-	-	193	-	-	-	386
AVEK Long Term Exchange Est.	2,936	-	-	-	2,935	-	-	5,871
DRWD 1-for-1 Long Term Exchange (Recharge) Est.	8,022	-	-	-	-	-	-	8,022
TOTAL 2023 TRANSACTIONS	11,913	9,921	9,926	193	2,935	-	749	35,637
Total Kern Water Bank	-	4,242	-	-	-	-	-	4,242
Total MWD System	12,033	-	-	-	-	-	43	12,076
Total Kern County	12,257	15,135	10,151	193	2,935	-	749	41,420
Total DRWD 1-for-1 Long Term Exchange Credit	6,978	-	-	-	-	-	-	6,978
TOTAL STORED WATER (1/1/2024)	31,268	19,377	10,151	193	2,935	-	792	64,716
(RECOVERY) AND RECHARGE IN 2024 (AF)								
KWB Recovery for use on Jackson Ranch ⁶ Est.	-	-	-	-	-	-	-	-
2024 SWP Allocation (15%)	-	-	-	-	-	-	-	-
BV Long Term Program Kern River Water Est.	-	-	-	-	-	-	-	-
AVEK Long Term Exchange Est.	-	-	-	-	-	-	-	-
Silver Tip 2023 Short Term Exchange	-	-	-	-	-	-	-	-
DRWD 1-for-1 Long Term Exchange (Recharge) Est.	1,886	-	-	-	-	-	-	1,886
TOTAL ESTIMATED 2024 TRANSACTIONS	1,886	-	-	-	-	-	-	1,886
ESTIMATED WATER IN STORAGE 2024 (AF)								
Total Kern Water Bank	-	4,242	-	-	-	-	-	4,242
Total MWD System	12,033	-	-	-	-	-	43	12,076
Total Kern County	14,143	15,135	10,151	193	2,935	-	749	43,306
Total DRWD 1-for-1 Long Term Exchange Credit	5,092	-	-	-	-	-	-	5,092
TOTAL ESTIMATED STORED WATER TO DATE	31,268	19,377	10,151	193	2,935	-	792	64,716

NOTES: Water in storage has been adjusted to account for losses. IRWD's water stored in Kern County is adjusted 15% for losses (5% for out of county loss, 6% surface loss, and 4% reserve loss); Water stored for BVWSD in Kern County is adjusted 10% (6% for surface loss and 4% for reserve loss); no losses for water directly delivered to MWD system.

MWD = Metropolitan Water District of Southern California.

¹ IRWD's SWP includes 251 AF from CVWD that stays in Kern County.

² IRWD's Non-SWP total includes 2,403 AF of Kern County Water Agency Article 21 Water.

³ DRWD water will be returned by MWD or IRWD's Strand Ranch to IRWD's Jackson Ranch. MWD took delivery of IRWD's 2022 SWP allocation in June 2022. MWD will not take delivery of IRWD's 2023 SWP Allocation.

⁴ IRWD's KWB Account balance includes SWP, Friant and Kern River water. The KWB account balance is included in the Non-SWP column because it is not exportable to IRWD's service area. The 2022 beginning KWB balance was revised by DRWD based on KCWA 2021 end of year balances.

⁵ Per the DRWD Long-Term 1-for-1 Exchange Program, Non-SWP water delivered to DRWD landowners will be returned to IRWD as SWP water at a later date. To account for the SWP water that will be returned at a later date, the amount of water owed will be shown as a credit. Total assumes all water is returned to IRWD Water Bank which adds in a 10% loss factor. Final amounts may be subject to additional CVC losses.

⁶ Water recovered from IRWD's Kern Water Bank account for use on Jackson Ranch.

⁷ A portion of IRWD's 2023 SWP Deliveries from DRWD include 723 AF of Article 21, after losses, which was delivered to the Kern Water Bank.

Note: This page is intentionally left blank.

Exhibit "D"

TABLE 4
Status of IRWD Purchase and Exchange Programs (AFTER LOSSES)
 March 21, 2024

PARTNER	EXCHANGE RATIO	YEAR EXECUTED	AGREEMENT TYPE	WATER TYPE	PARTNER WATER		IRWD WATER							SELLABLE (Y/N)		
					PARTNER SHARE (AF)	PARTNER BALANCE (AF)	IRWD SHARE (AF)	IRWD BALANCE			EXPORTABILITY					
								IN MWD SYSTEM (AF)	STORED IN KERN (AF)		OWED BY DUDLEY RIDGE WD	TOTAL (AF)	EXPORTABLE TO IRWD (AF)		NON-EXPORTABLE (AF)	FOR USE ON JACKSON RANCH (DRWD)
		Strand and Stockdale	Kern Fan (W.Enos)													
Semitropic Water Storage District	NA	2008	Purchase	SWP Article 21	NA	NA	2,842		2,403			2,403		2,403		Yes
Carpinteria Valley Water District	2-for-1	2008	Short-Term	SWP Table A	277		250		250			250		250		Yes
Buena Vista Water Storage District ¹	2-for-1	2010	Pilot	Kern River	4,108		3,903									Yes
	2-for-1	2011	Long-Term	Kern River	29,369	8,121	27,900		10,803	0		10,803		10,803		
Antelope Valley East Kern Water Agency	2-for-1	2011	Pilot	SWP Table A	2,229		2,337	2,337				2,337	2,337			No
Carpinteria Valley Water District	2-for-1	2011	Pilot	SWP Table A	624		655	655				655	655			No
Dudley Ridge Water District (SWPAO #13012)	2-for-1	2013	SWPAO	SWP Table A	1,876		1,876	1,876				1,876	1,876			Yes
				SWP Article 21	1,553		1,554	1,554			1,554	1,554			Yes	
Metropolitan Water District ²	1-for-1	2014	Short-Term	SWP Table A	NA	NA	4,000	4,000				4,000	4,000			No
Dudley Ridge Water District (SWPAO #17030)	2-for-1	2018	SWPAO	SWP Table A	1,803	792	1,887	1,055	831			1,887	1,887		792	Yes
Central Coast Water Authority (SWPAO #17001)	2-for-1	2017	Short-Term	SWP Table A	258		258	258				258	258			No
Dudley Ridge Water District ³ (SWPAO #19001)	1-for-1	2017	Long-Term	SWP Table A	NA	NA	9,908		9,682	226		9,908	15,000			No
				Credit	NA	NA	5,092			5,092	5,092				No	
Central Coast Water Authority (SWPAO #19031)	2-for-1	2019	Short-Term	SWP Table A	298		323	298	25			323	323			No
Buena Vista Water Storage District ¹	2-for-1	2023	Short-Term	Kern River	2,030	2,030	1,929		1,268	661		1,929		1,929		Yes
Central Coast Water Authority (SWPAO #23012)	2-for-1	2023	Short-Term	SWP Table A	193	193	193		193			193	193			No
Antelope Valley East Kern Water Agency	2-for-1	2018	Long-Term	SWP Table A	2,935	2,935	2,936		2,041	895		2,936	2,936			No
Total:					47,554	14,071	67,843	12,033	27,496	1,782	5,092	46,403	31,018	15,385	792	NA

¹ Water acquired through BVWSD will be exportable after it is exchanged for SWP Table A through 1-for-1 exchange with Dudley Ridge Water District.

² Source of water was Buena Vista Water Storage District Kern River high flow water.

³ To account for the SWP water that will be returned to IRWD, the amount of water owed is shown as a credit. The total net of losses is 15,000 AF.

Note: This page is intentionally left blank.

Exhibit "E"

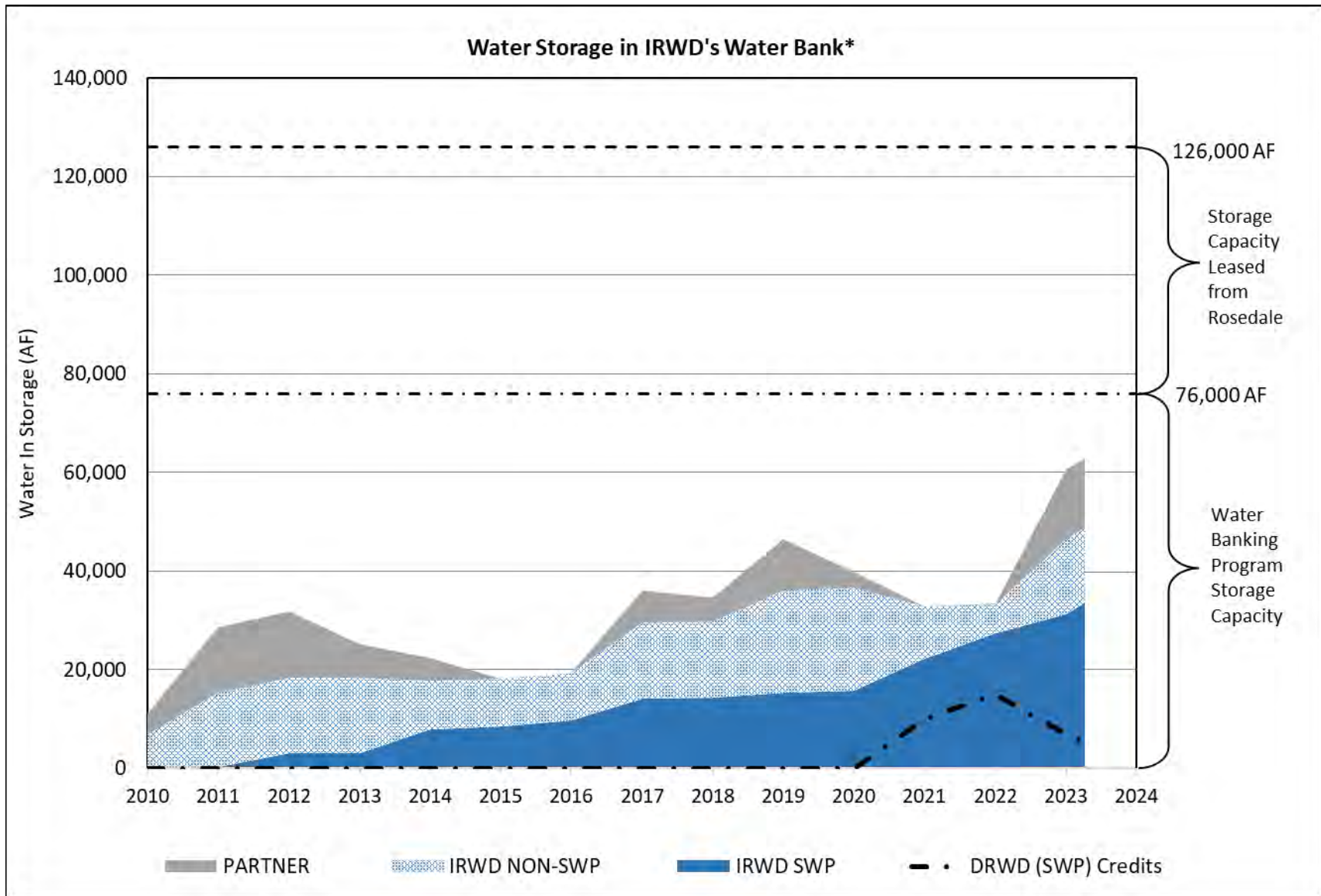

*After losses

Note: This page is intentionally left blank.

Exhibit "F"

TABLE 5
IRWD Dedicated Water Banking Capacities for Existing and Proposed Exchange Programs
 March 21, 2024

STORAGE CAPACITY

Program	Dedicated Storage Capacity Strand Ranch (AF)	Dedicated Storage Capacity Stockdale West (AF)	Dedicated Storage Capacity Leased Storage Account (AF)	Kern Water Bank Storage Capacity (AF)
Total Capacity	50,000	26,000	50,000	9,495
BVWSD	40,000	-	-	-
DRWD	10,000	-	-	-
AVEK	-	20,000	-	-
Total Dedicated	50,000	20,000	-	-
Total Remaining	-	6,000	50,000	9,495

RECHARGE CAPACITY

Program	Dedicated Recharge Capacity Strand Ranch (AF)	Dedicated Recharge Capacity Stockdale West (AF)	Dedicated Recharge Capacity Leased Storage Account (AF)	Kern Water Bank Recharge Capacity (AF)
Total Capacity	17,500	27,100	-	3,200
BVWSD	17,500	-	-	-
DRWD	-	-	-	-
AVEK	-	20,000	-	-
Total Dedicated	17,500	20,000	-	-
Total Remaining	-	7,100	-	3,200

RECOVERY CAPACITY

Program Partner	Dedicated Recovery Capacity Strand Ranch (AF)	Dedicated Recovery Capacity Stockdale West (AF)	Dedicated Recovery Capacity Leased Storage Account (AF)	Kern Water Bank Recovery Capacity (AF)
Total Capacity	17,500	11,250	-	1,520
BVWSD	6,667	-	-	-
DRWD	-	-	-	-
AVEK	-	3,333	-	-
IRWD	10,833	7,084	-	1,520
Total Dedicated	17,500	10,417	-	1,520
Total Remaining	-	833	-	-

Note: This page is intentionally left blank.



Location Map: IRWD Water Banking Projects Wells and Turnin Pipelines

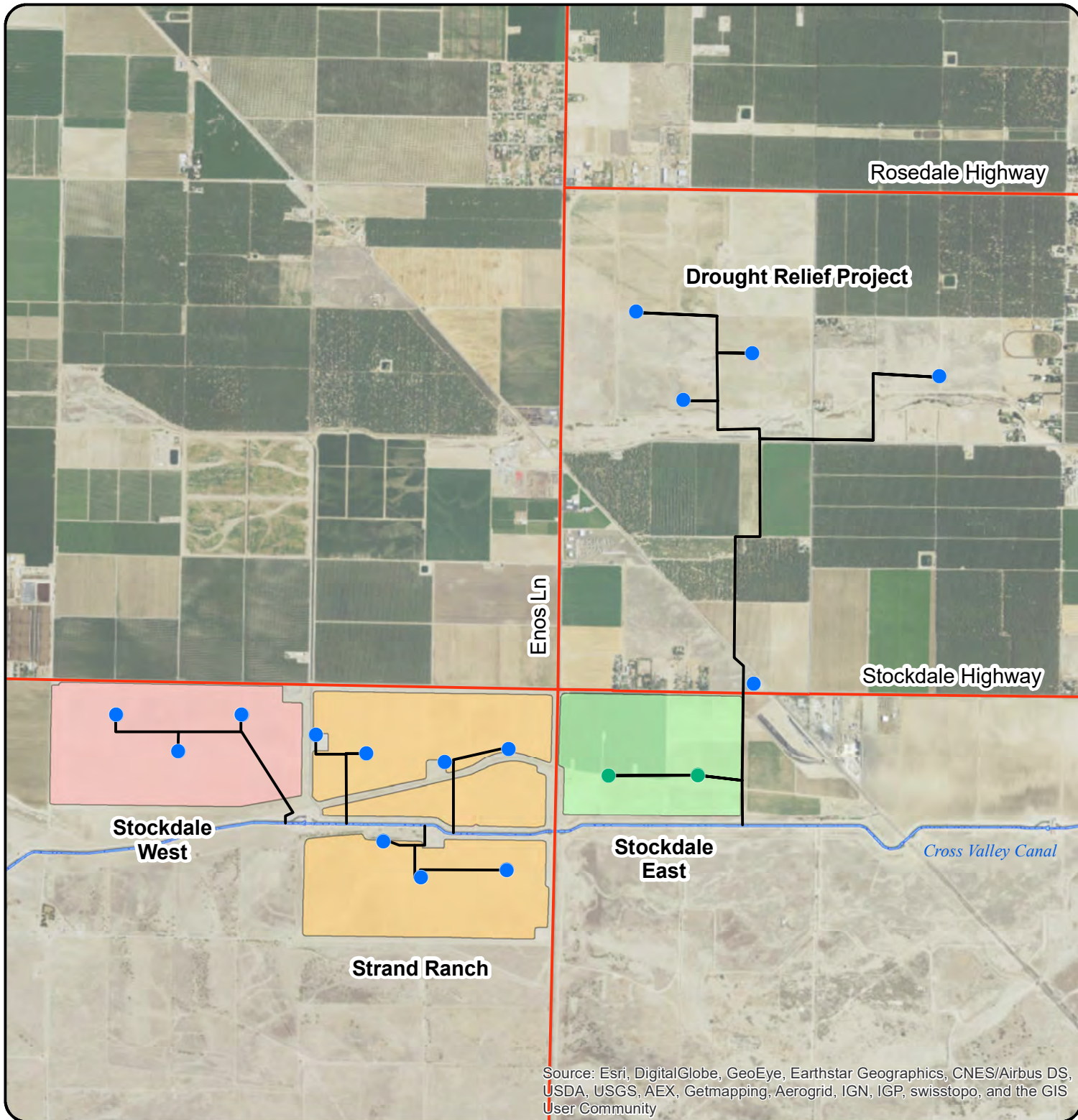

MAP FEATURES

- Extraction Well
- Extraction Well
- Well Discharge Pipelines
- Stockdale East
- Stockdale West
- Strand Ranch

This figure shows the location of IRWD's water banking project sites and extraction wells.

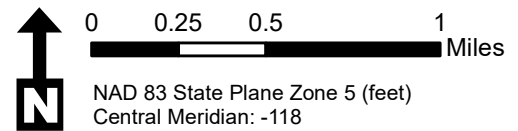

Source: Esri, DigitalGlobe, GeoEye, Earthstar Geographics, CNES/Airbus DS, USDA, USGS, AEX, Getmapping, Aerogrid, IGN, IGP, swisstopo, and the GIS User Community

Note: This page is intentionally left blank.



Location Map: IRWD Water Banking Projects Recharge Basins & Turnout Facilities

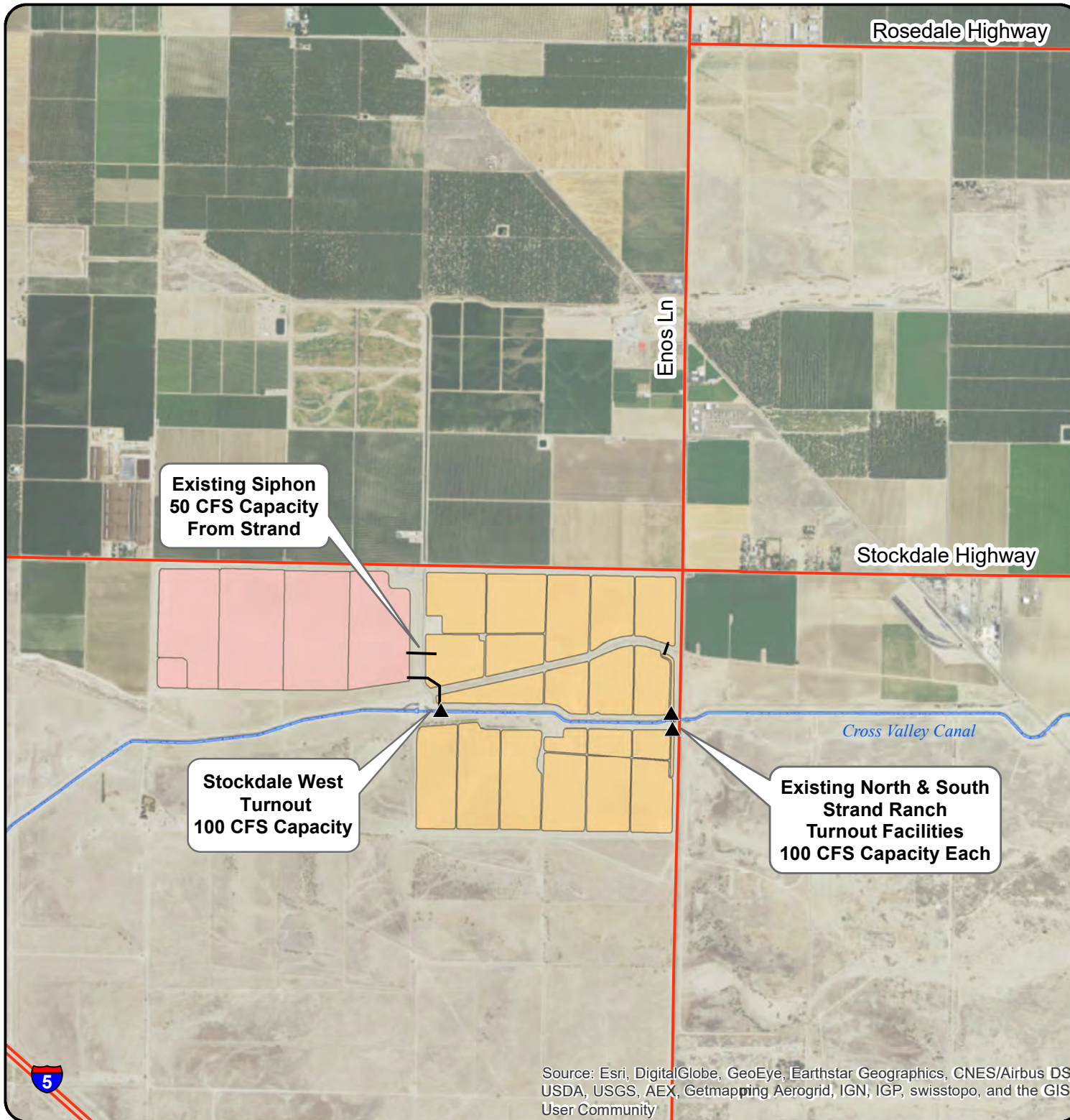

MAP FEATURES

- ▲ Turnouts
- Stockdale West
- Strand Ranch

This figure shows the location of recharge basins, pipelines and turnout facilities.

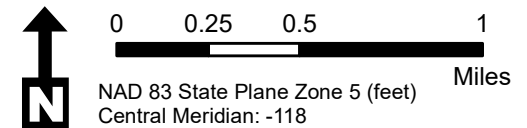

Source: Esri, DigitalGlobe, GeoEye, Earthstar Geographics, CNES/Airbus DS, USDA, USGS, AEX, Getmapping AeroGrid, IGN, IGP, swisstopo, and the GIS User Community

Note: This page is intentionally left blank.



Location Map: IRWD Water Banking Projects Recharge Rates

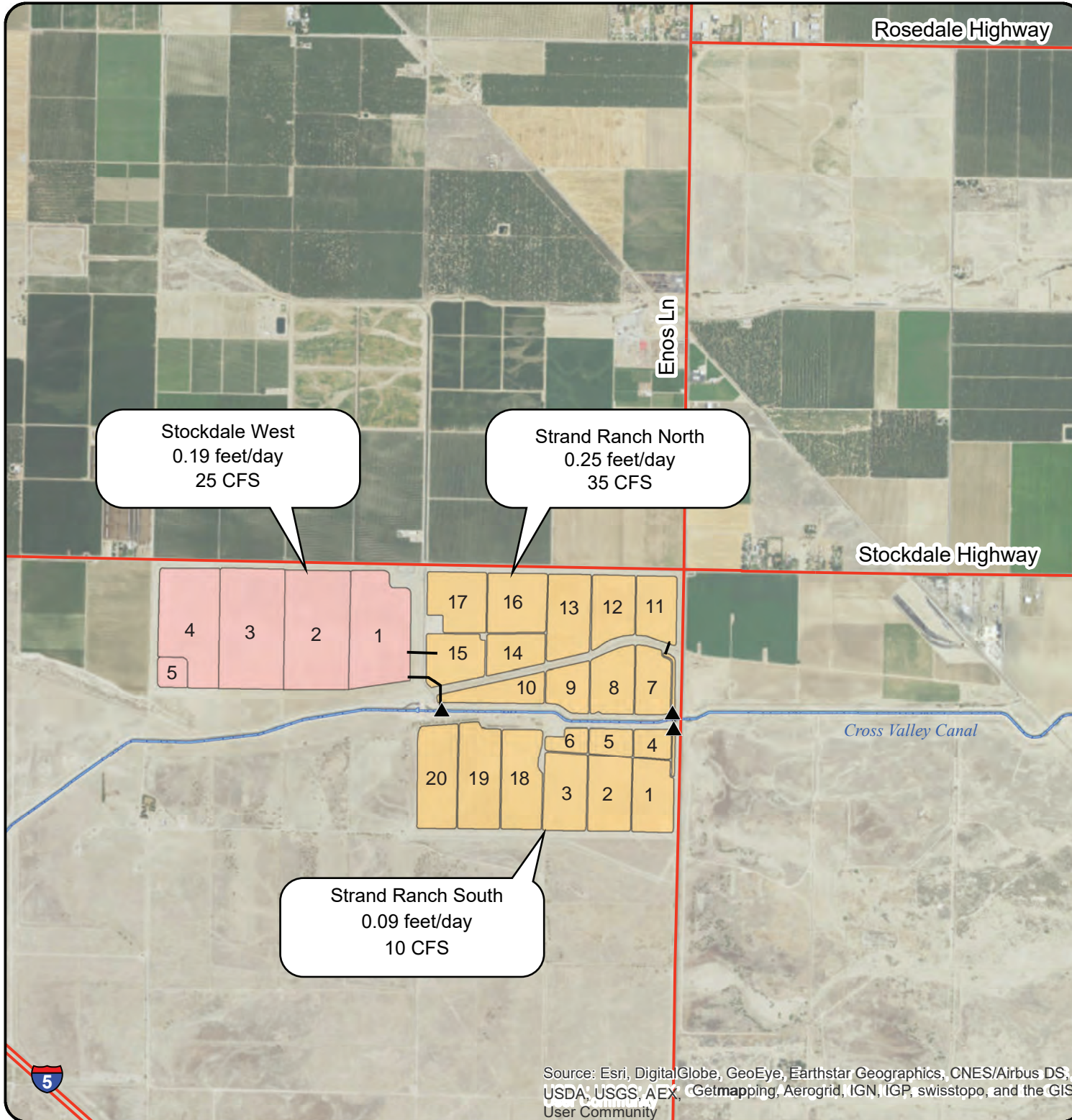

MAP FEATURES

- ▲ Turnouts
- Stockdale West
- Strand Ranch

This figure shows the location of recharge basins and their associated recharge rates as of January 4, 2024

Source: Esri, DigitalGlobe, GeoEye, Earthstar Geographics, CNES/Airbus DS, USDA, USGS, AEX, Getmapping, Aerogrid, IGN, IGP, swisstopo, and the GIS User Community

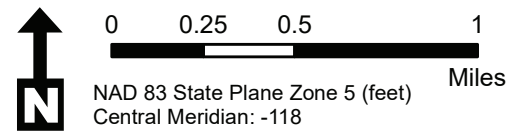

Note: This page is intentionally left blank.

Exhibit "J"
IRWD-Rosedale Water Banking and Exchange Program Agreements
 Effective 1/12/2009 through 1/12/2039 (Strand Ranch)
 2/4/2016 through 1/12/2039 (Stockdale West)

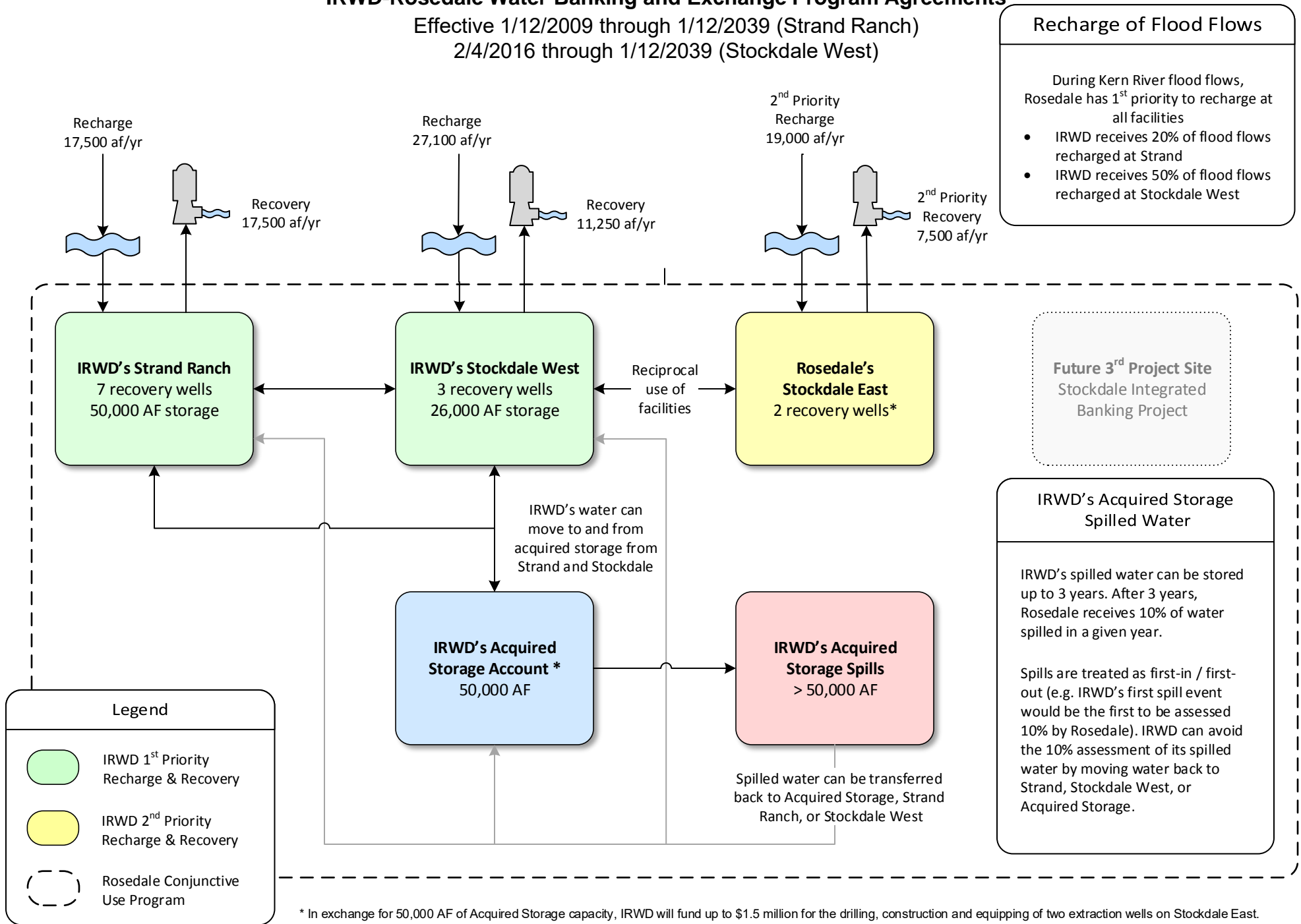



Note: This page is intentionally left blank.

Buena Vista Water Storage District Long Term Water Exchange Program
 Effective 1/1/2011 through 1/12/2039

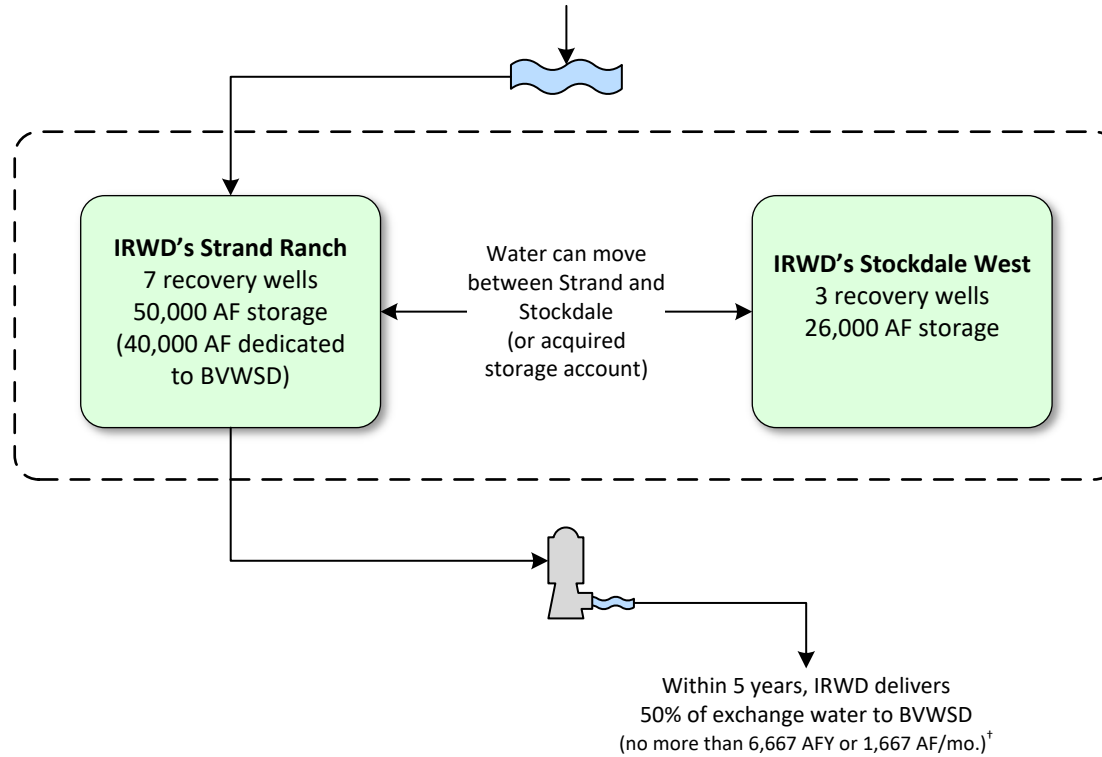
BVWSD delivers non-SWP water to Strand Ranch
 (IRWD receives 50%)
 (Up to 17,500 AFY or 4,375 AF/mo.)



Legend	
	IRWD 1 st Priority Recharge & Recovery
	Rosedale Conjunctive Use Program & Coordinated Operation

†IRWD shall remit one-half of the exchanged supply less one-half of reasonable losses back to BV no later than December 31st of the 4th year following the associated recharge event. IRWD pays for recovery of water returned to BV. Water to be remitted back to BV may remain in storage at Strand Ranch beyond the 4th year, in exchange for a greater percent being transferred to IRWD as compensation per the table shown to the right:

Year Following Recharge Event	Percent Transferred to IRWD	Percent Returned to BV During or Before Indicated Year
1	50%	50%
2	50%	50%
3	50%	50%
4	50%	50%
5	60%	40%
6	70%	30%
7	80%	20%
8	90%	10%
9	100%	0%

Buena Vista Water Storage District One-Year Program to Augment Recharge Using Stockdale West Recharge Facilities

Effective 6/28/2023 through 12/31/2023

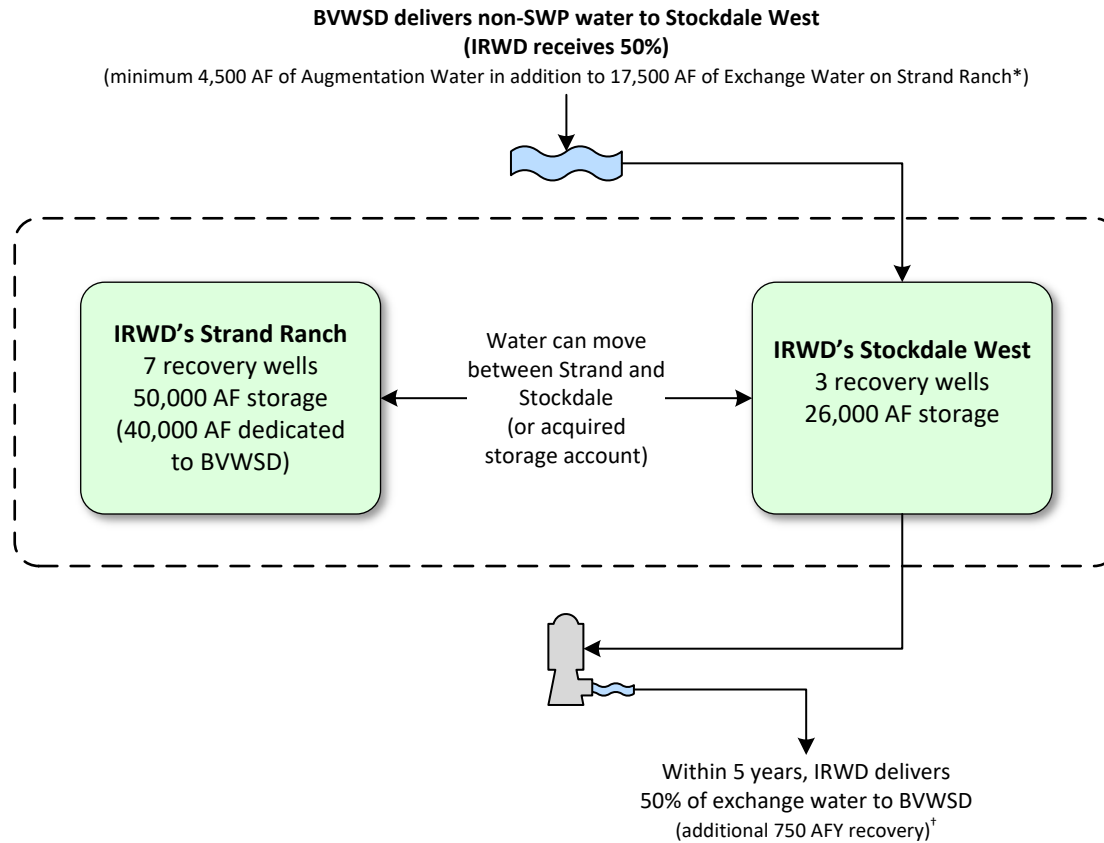

Legend	
	IRWD 1 st Priority Recharge & Recovery
	Rosedale Conjunctive Use Program & Coordinated Operation

* IRWD agrees to pay BV \$25 per AF for IRWD's share of the Augmentation Water and Exchange Water

[†]IRWD shall remit one-half of the exchanged supply less one-half of reasonable losses back to BV no later than December 31st of the 4th year following the associated recharge event. BV pays for recovery of its share of Augmentation Water. Water to be remitted back to BV may remain in storage at Strand Ranch beyond the 4th year, in exchange for a greater percent being transferred to IRWD as compensation per the table shown to the right:

Year Following Recharge Event	Percent Transferred to IRWD	Percent Returned to BV During or Before Indicated Year
1	50%	50%
2	50%	50%
3	50%	50%
4	50%	50%
5	60%	40%
6	70%	30%
7	80%	20%
8	90%	10%
9	100%	0%

Exhibit "L"
Dudley Ridge Water District (DRWD) Unbalanced Exchange Program
 Up to 12,240 AF delivered from 6/7/2018 through 12/31/2027

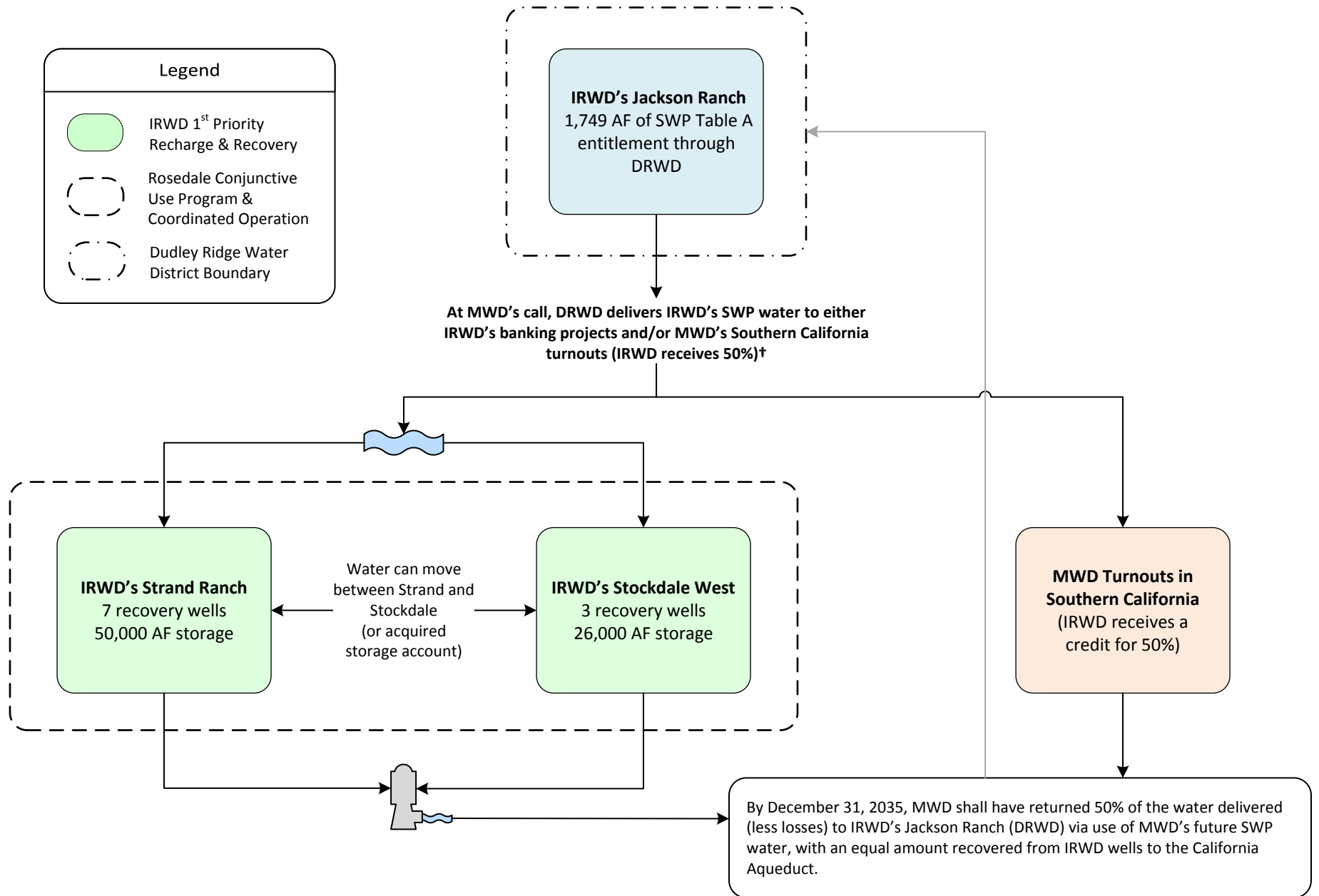

†Consistent with IRWD-MWD coordinated operating agreement.

Note: This page is intentionally left blank.

Coordinated Operating, Water Storage, Exchange and Delivery Agreement Between MWD, MWDOC and IRWD
 Effective 5/1/2011 through 11/4/2035

With MWD's consent, IRWD secures SWP water (Program Water) through exchanges with IRWD Banking Partners for use as extraordinary supply under MWD Water Supply Allocation Plan

MWD has three options for the use and storage of Program Water:

- Storage of water in IRWD's Integrated Banking Project
- Delivery to Southern California for immediate use and/or storage in MWD system
- Borrow a portion of Program water, with accrual in MWD Delivery Account

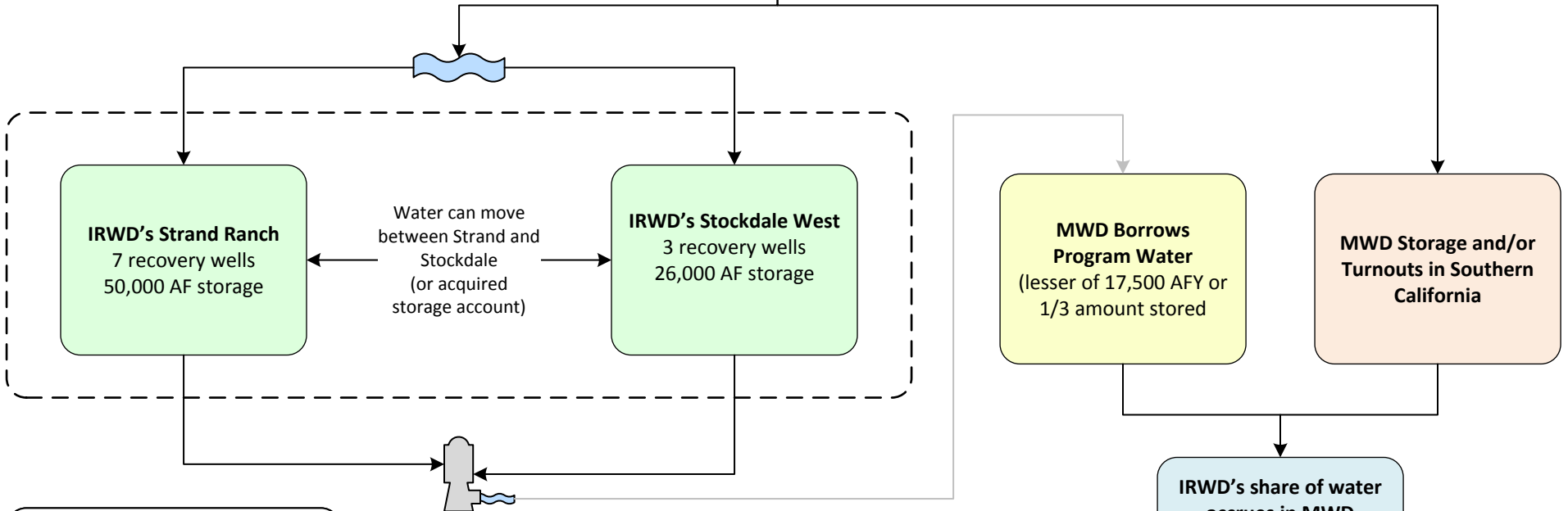

Legend

- IRWD 1st Integrated Banking Project
- Rosedale Conjunctive Use Program & Coordinated Operation

- Under an MWD Allocation, when IRWD calls for water, IRWD must first recover Program Water from the Integrated Banking Project before receiving water from the MWD Delivery Account.
- MWDOC shall pass through extraordinary supply credits for IRWD's benefit.
- † IRWD's banking partner share of Program Water to be returned by MWD.

Note: This page is intentionally left blank.

Exhibit "N"

Agreement for Conveyance of Water Between MWD, MWDOC, and IRWD (Wheeling Agreement) Template for future agreements

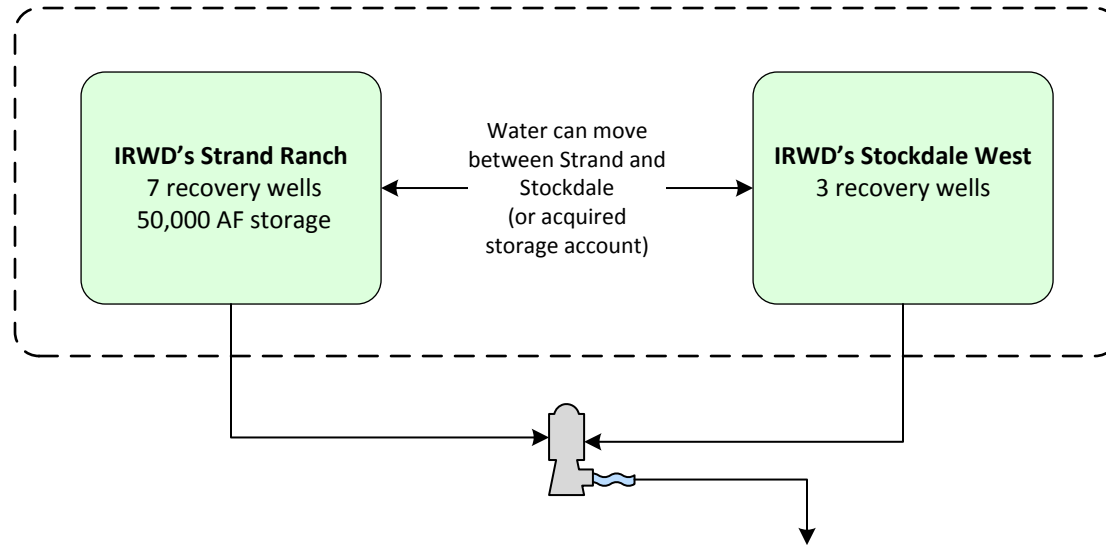

IRWD recovers its share of non-SWP water from its Integrated Banking Projects for use as extraordinary supply under a declared MWD Water Supply Allocation. MWD will coordinate the conveyance and delivery of recovered water to be used within IRWD's Service Area. Delivery can also occur through an operational exchange.*

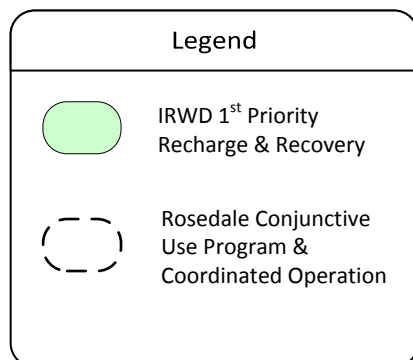

*The recovered water must be used within IRWD's service area. IRWD to pay MWD wheeling charges, including system access rate, water stewardship rate, and treatment surcharge (if applicable), for each acre foot of recovered water wheeled by MWD. IRWD will pay the actual costs of power incurred by MWD to convey recovered water in the California Aqueduct to IRWD delivery points.

Note: This page is intentionally left blank.

Dudley Ridge Water District Long Term 1-for-1 Water Exchange Program
 Effective 5/31/2017 through 11/4/2035

Scenario A
 (Per Sections 2, 3, 4.1.1, and 4.1.3)

x= Non-Project Water required to stay in Kern County
 y= Non-Project Water allowed to leave Kern County
 z= DRWD Table A Water equal to x+y less applicable losses, if any

Per Section 4.1.3, z can be delivered to IRWD via in-ground transfer to IRWD, SWP delivery to IRWD banking facilities, or SWP delivery to MWDSC

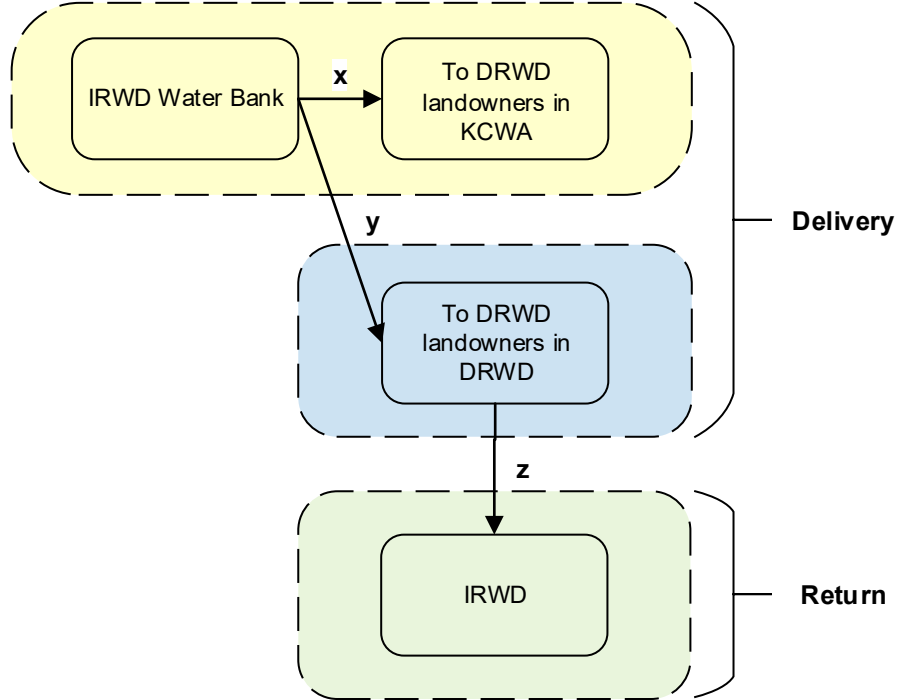

Scenario B
 (Per Sections 2, 3, and 4.1.2)

$a + b = c + d$
 (less applicable losses, if any)

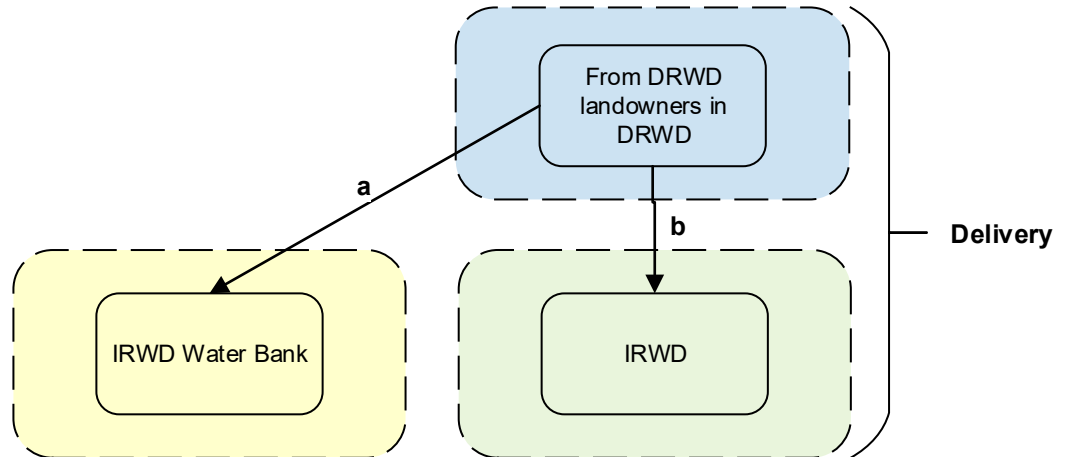

Legend

- KCWA Service Area
- DRWD Service Area
- IRWD Service Area

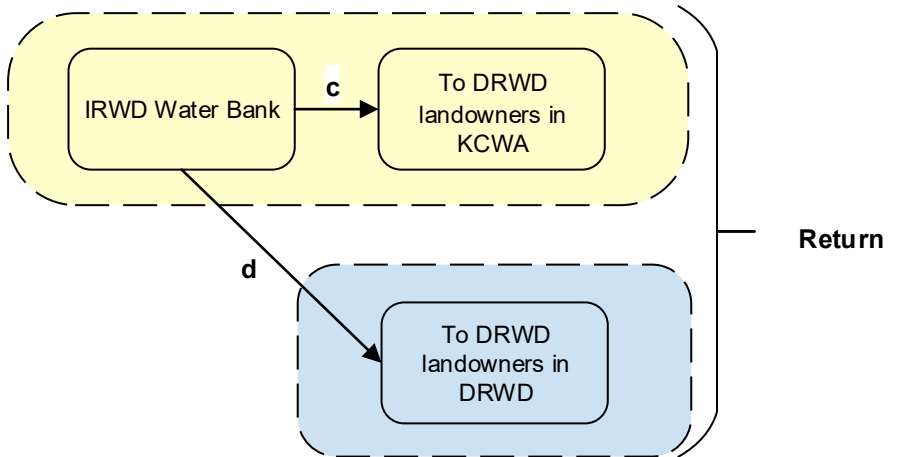

Note: This page is intentionally left blank.



Exhibit "P"

Antelope Valle-East Kern Water Agency (AVEK) Long Term Water Exchange Program Effective 12/21/2018 through 12/31/2035

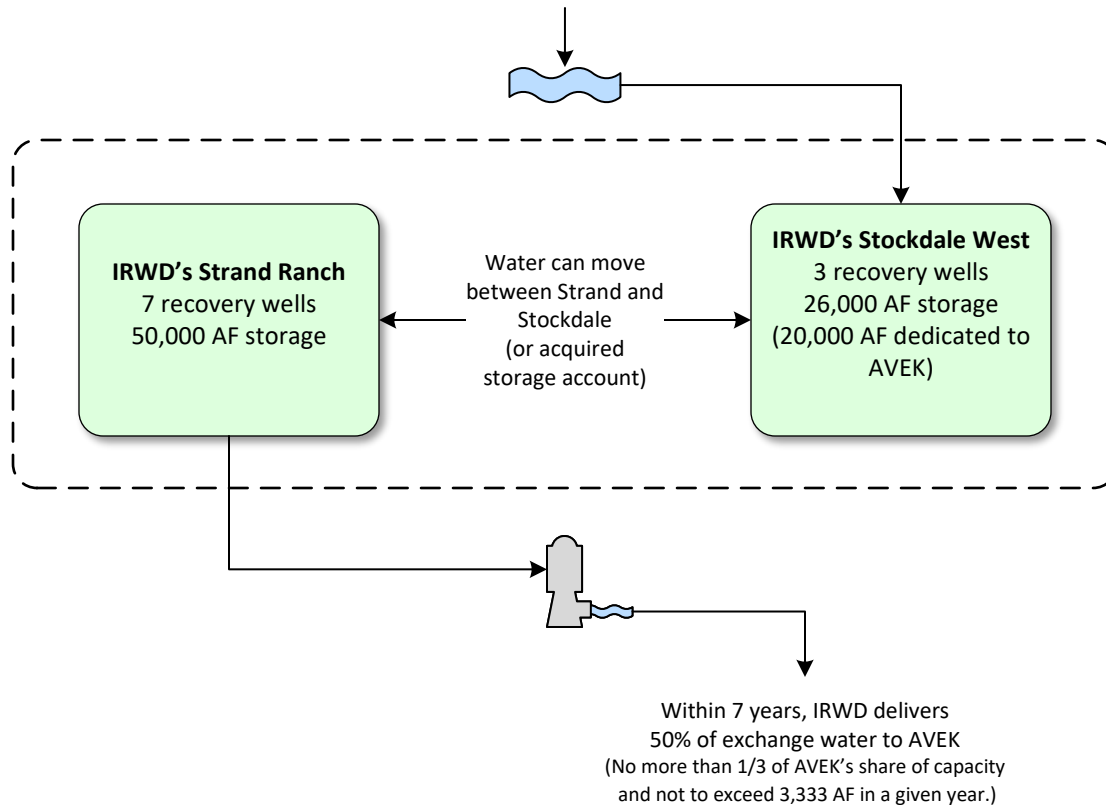
AVEK delivers SWP water to IRWD Water Bank
(IRWD receives 50%)
(Up to 20,000 AFY or 2,200 AF/mo.)*



Legend

-  IRWD 1st Priority Recharge & Recovery
-  Rosedale Conjunctive Use Program & Coordinated Operation

*Up to 20,000 AF per year of AVEK Exchange Water may be delivered to IRWD for recharge using recharge facilities at the Strand Ranch and Stockdale West for storage in the Stockdale West Bank. IRWD shall remit one-half of stored supplies less one half of losses back to AVEK no later than December 31st of the 7th year, following the associated recharge event.

Note: This page is intentionally left blank.

Exhibit "Q"

TABLE 6
IRWD Water Banking Program Costs of Water Summary
 March 21, 2024

Program Partner	Time Period	Water Type	IRWD Amount (AF)	Variable costs ² (\$/AF)	Fixed Cost Component ³ (\$/AF)	Fixed & Variable (\$/AF)	Capital Component ⁴ (\$/AF)	Cost of Water (\$/AF)	Estimated Recovery of Water ⁵ (\$/AF)	2024 MWD Tier 1 Untreated Rate + SAC Surcharge ⁶ (\$/AF)	Cost of Water in IRWD Service Area (\$/AF)
				(A)	(B)	(C)	(D)	(E)	(F)	(G)	(H)
						A+B		C+D			E+F+G
Buena Vista	2010-2015	Kern River	12,832	\$ 75.98	\$ 48.36	\$124.34	\$ 190.00	\$ 314.34	\$ 120.00	\$ 903.99	\$ 1,338.33
Buena Vista ¹	2017-2021	Kern River	11,256	\$ 159.16	\$ 48.36	\$207.52	\$ 190.00	\$ 397.52	\$ 120.00	\$ 903.99	\$ 1,421.51
AVEK	2012-2014	SWP Table A	2,229	\$ 11.70	\$ 48.36	\$ 60.06	\$ 190.00	\$ 250.06	\$ 120.00	\$ 903.99	\$ 1,274.05
AVEK ⁷	2012-2014	SWP Table A	108	\$ 11.70	\$ 48.36	\$ 60.06	\$ 190.00	\$ 250.06	\$ -	\$ 903.99	\$ 1,154.05
Carpinteria	2010-2015	SWP Table A	874	\$ 27.04	\$ 48.36	\$ 75.40	\$ 190.00	\$ 265.40	\$ 120.00	\$ 903.99	\$ 1,289.39
Carpinteria ⁷	2010-2015	SWP Table A	31	\$ 27.04	\$ 48.36	\$ 75.40	\$ 190.00	\$ 265.40	\$ -	\$ 903.99	\$ 1,169.39
Central Coast ⁷	2017-2021	SWP Table A	556	\$ 30.34	\$ 48.36	\$ 78.70	\$ 190.00	\$ 268.70	\$ -	\$ 903.99	\$ 1,172.69
DRWD ⁷	2014-2021	SWP Table A /Article 21	4,452	\$ 362.67	\$ 48.36	\$411.03	\$ 190.00	\$ 601.03	\$ -	\$ 903.99	\$ 1,505.02
Total			32,338								

¹ Water purchased in 2019 includes commodity charge of \$110/AF

² Variable Costs shown above are based on actual costs. The different components and average costs included in the variable cost are as follows: recharge variable operating costs (\$5.00/AF), Rosedale administration fees (\$3.00/AF), CVC pumping (\$9.00/AF), operating and stand-by fees (\$3.50/AF), and KCWA fees (\$5.00/AF) plus \$3,000 per transaction request. IRWD pays Buena Vista recovery costs. (Net of partner payments to IRWD for their share of water)

³ Fixed costs include IRWD share of fixed operating costs (\$25.00/AF), annual property taxes (\$88,000), PG&E standby costs (up to \$5,000/year), GSP fees (\$8,450/year) and CVC expansion costs (\$28,000/year)

⁴ Capital component does not include land costs, grants received, and revenue from DRWD water sold in 2021. Add \$60/AF to include these costs.

⁵ Increased PG&E costs for recovering water.

⁶ Assumes IRWD would take delivery as extraordinary supply through Irvine Lake to the Baker Water Treatment Plant. The SAC surcharge rate as of 6/30/2023 was \$0.99 per AF.

⁷ No recovery costs for DRWD water delivered in 2014-2016 and water recovered in 2022 as part of MWD borrowing.

Note: This page is intentionally left blank.

Exhibit “R”

Summary of IRWD’s Coordinated Operating, Water Storage, Exchange and Delivery Agreement with Metropolitan Water District and Municipal Water District of Orange County (MWDOC) (February 8, 2024)

Agreement approved (unanimously) by the IRWD Board on November 22, 2010;
Agreement Term: April 21, 2011 to November 4, 2035

Summary of Benefits to IRWD:

1. IRWD benefits from all State Water Project (SWP) water IRWD secures; Metropolitan’s borrowing of this water is temporary.
2. On behalf of IRWD, Metropolitan uses its SWP exchange and conveyance capacities to move IRWD’s water for banking.
3. IRWD can “store” water in Metropolitan’s system as a credit, freeing up space in IRWD’s Water Bank with the water stored closer to the IRWD service area.
4. IRWD does not incur conveyance or evaporation losses on its water that is conveyed in Metropolitan’s system and stored in Metropolitan’s reservoirs.
5. IRWD avoids groundwater recovery (pumping) costs when Metropolitan issues a credit for IRWD’s SWP supplies in Southern California (currently \$122/AF¹).
6. IRWD pays Metropolitan’s melded system power rate – currently \$182/AF, not DWR’s current power costs of \$330/AF² (\$148/AF savings).
7. Deliveries are on-demand to IRWD at its service connections in Orange County, which are not subject to lower priorities for wheeling.
8. Metropolitan pays all SWP costs, including variable OMP&R supply costs, associated with SWP water secured by IRWD³.
9. IRWD pays Metropolitan’s Full-Service Tier-1 Untreated Rate, which is currently \$903/AF, for deliveries at its service connections allowing IRWD to avoid higher Metropolitan wheeling charges.
10. IRWD only pays once for supply at the current Tier-1 Supply Rate of \$332/AF.
11. Deliveries to IRWD’s service area qualify as Extraordinary Supply during a Water Supply Allocation, allowing IRWD to avoid Metropolitan’s Allocation Surcharge of between \$1,480/AF and \$2,960/AF.
12. IRWD increases local water supply reliability for its ratepayers.

¹ Estimated from IRWD’s current groundwater pumping costs and Water Bank related operations costs. Metropolitan has the option to extinguish credits by returning water to the IRWD Water Bank. In recent borrowing letter agreement, Metropolitan agreed to waive its ability to return borrowed water to the Water Bank.

² Melded system and actual power costs were taken from Metropolitan’s Fiscal Years 2022-23 and 2023-24 Biennial Budget Report and 2022 Cost of Service Study.

³ Does not include fixed costs paid by IRWD’s unbalanced exchange partners. In 2014 and 2017, Metropolitan’s SWP costs were \$1,097/AF and \$359/AF, respectively.

Summary of Benefits to MWD:

1. Metropolitan maintains control of all SWP supplies entering its service area as required by its SWP Contract with California Department of Water Resources (DWR).
2. Metropolitan's investments in the SWP are protected by not causing a reduction in revenue received by Metropolitan for payment of SWP fixed charge obligations.
3. Metropolitan can temporarily borrow SWP water secured by IRWD.
4. Metropolitan is assured that IRWD is not competing for water supplies.
5. Increased regional water supply reliability.

Exhibit "S"

IRWD 2024 Recharge Operations- BEFORE LOSSES

March 21, 2024

Actual and Forecasted Amounts:

Month	IRWD Table A (AF)	DRWD 1:1 (AF)	Buena Vista (AF)	AVEK (AF)	Homer (AF)	Valley Water (AF)	Silver Tip (AF)	Total (AF)	Status	Expected Recharge ¹ (AF)	Expected Recharge Rate (CFS)
January	-	2,200	-	-	-	-	-	2,200	prelim	2,200	80
February	-	-	-	-	-	-	-	-	prelim	-	70
	-	2,200	-	-	-	-	-	2,200		2,200	
March	-	-	-	-	-	-	-	-		-	60
April	-	-	-	-	-	-	2,000	2,000		2,000	60
May	-	-	-	-	-	3,689	-	3,689		3,689	60
June	-	-	-	-	-	3,570	-	3,570		3,570	60
July	-	-	-	-	-	3,689	-	3,689		3,689	60
August	-	-	-	-	-	3,689	-	3,689		3,689	60
September	-	-	-	-	-	3,570	-	3,570		3,570	60
October	262	-	-	-	1,636	1,792	-	3,689		3,689	60
November	-	-	-	-	164	-	463	627		627	60
December	-	-	-	-	-	-	1,537	1,537		1,537	60
	262	2,200	-	-	1,800	20,000	4,000	28,262		28,262	
Recharge goal:	262	7,142	-	-	1,800	20,000	4,000	33,204			

Note: This page is intentionally left blank.

March 21, 2024

Prepared by: N. Palacio / K. Welch

Submitted by: F. Sanchez / P. Weghorst

Approved by: Paul A. Cook 

SUPPLY RELIABILITY PROGRAMS COMMITTEE

UPDATE ON IRWD AGRICULTURAL LAND LEASES

SUMMARY:

IRWD owns property in Kings and Riverside Counties for water supply reliability purposes. These agricultural properties are currently farmed through tenant farm leases and contract farming arrangements. At the Committee meeting, staff will provide an update on IRWD's current farm lease and contract farming agreements.

BACKGROUND:

Since 2010, IRWD has purchased approximately 4,000 acres of farmland that are operational agricultural properties used for water supply reliability purposes. These properties are located in both Kings and Riverside Counties as described below.

Kings County Properties:

In 2010, IRWD purchased 883 acres of farmland in Kings County known as the Jackson Ranch. This property is located within the service area of Dudley Ridge Water District, which is a State Water Project (SWP) contractor. The Jackson Ranch includes rights to the use of 1,749 acre-feet (AF) of SWP Table A water. In accordance with the Dudley Ridge Rules and Regulations, IRWD can make use of 50% of the allocated Table A supplies in IRWD's service area with the remainder to be used on IRWD's Jackson Ranch or on other lands in Dudley Ridge. A location map of the property is attached as Exhibit "A".

IRWD regulates its Table A supplies through storage at the IRWD Water Bank in Kern County. IRWD has agreements in place with Dudley Ridge, Metropolitan Water District, Kern County Water Agency, and the California Department of Water Resources that allow IRWD to make use of half of these supplies in IRWD's service area.

Tenant Farming Arrangements:

Since 2014, Mr. Brett Adee of Adee Honey Farms has leased the Jackson Ranch primarily for bee foraging. The original lease was for a 5-year term with an option for multiple extensions. IRWD has executed three lease amendments extending the lease term. The current lease amendment will terminate on May 14, 2025. Under the lease, Mr. Adee can purchase up to 235 AF of water per year from IRWD, and additional supplemental water above 235 AF if IRWD determines it to be available. The water is sold to Mr. Adee at cost plus applicable IRWD Water Bank costs. The lessee is required to keep the property maintained such that all areas are free of weeds.

Riverside County Properties:

IRWD owns 3,101 acres of land within the Palo Verde Irrigation District (PVID), of which 2,845 are water toll acres. PVID is in Riverside County adjacent to the Colorado River and has the highest priority rights to Colorado River water in California. Ownership of this land will eventually become another element of IRWD's long-term program to increase water supply reliability for its customers during droughts and other potential water supply interruptions. The location and total acres of IRWD's properties are shown in Exhibit "B".

Tenant and Contract Farming Arrangements:

IRWD's properties in PVID are currently farmed by tenant farmers and through contract arrangements. IRWD receives payments for rent and water tolls as well as proceeds from hay sales. IRWD expects to continue with this practice. All IRWD properties in PVID are enrolled in the Palo Verde Land Management, Crop Rotation, and Water Supply Program (Following Program). IRWD receives payments from Metropolitan Water District for water conserved on the fallowed areas through the Following Program.

Exhibit "C" includes a summary of the current farming leases and contract farming agreements on IRWD lands in Kings and Riverside Counties. At the Committee meeting, staff will provide additional information related to the leases and contract farming agreements.

FISCAL IMPACTS:

Payments received by IRWD on its agricultural lands in Kings and Riverside County are applied as offsets to IRWD's cost of water.

ENVIRONMENTAL COMPLIANCE:

Not applicable.

RECOMMENDATION:

Receive and file.

LIST OF EXHIBITS:

Exhibit "A" – Location Map of IRWD's Jackson Ranch Property in Dudley Ridge

Exhibit "B" – Location Map of IRWD Owned Properties in PVID

Exhibit "C" – Summary of Agricultural Land Leases

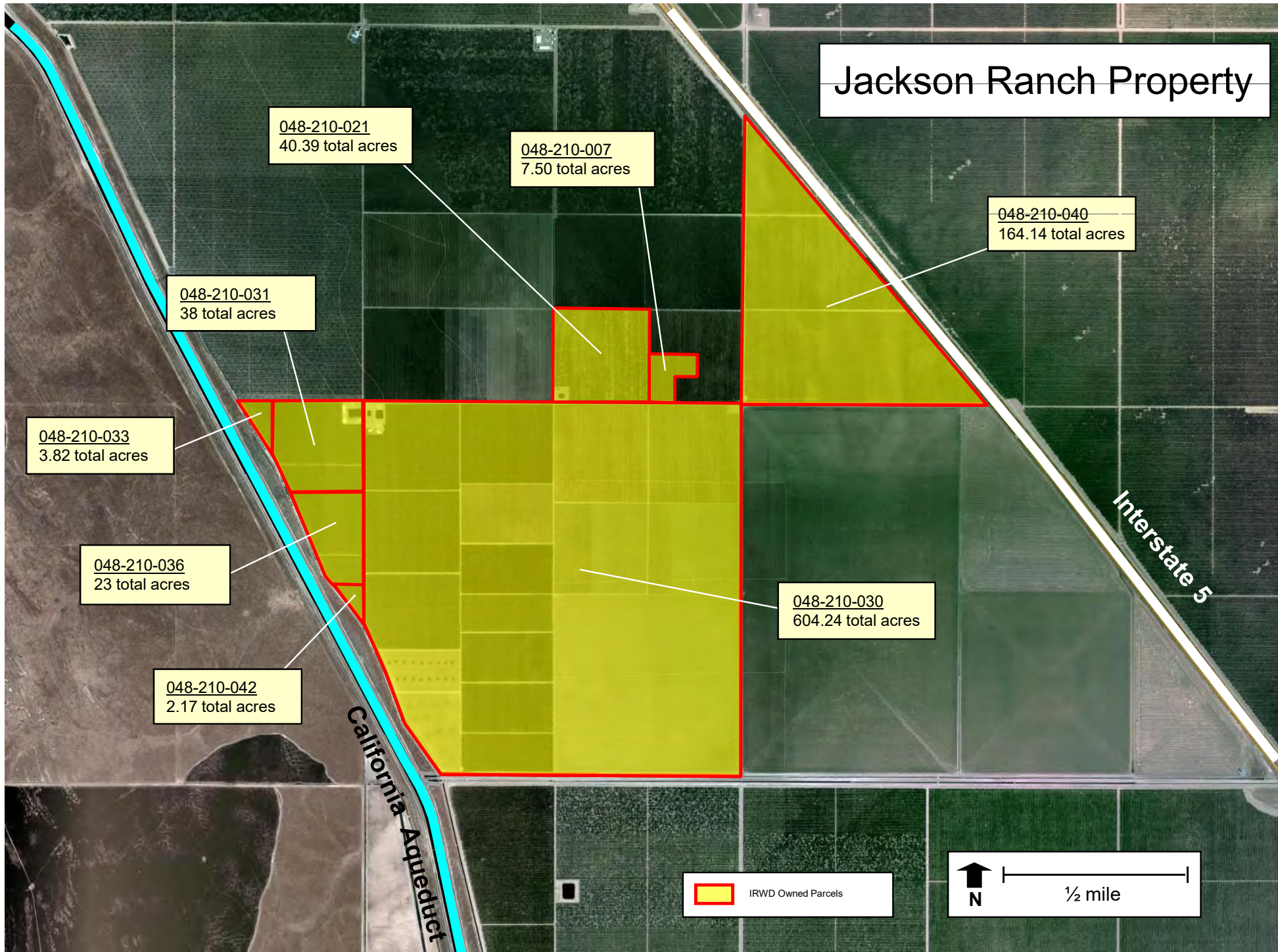

Note: This page is intentionally left blank.

Exhibit "B"
 IRWD PVID Owned Properties

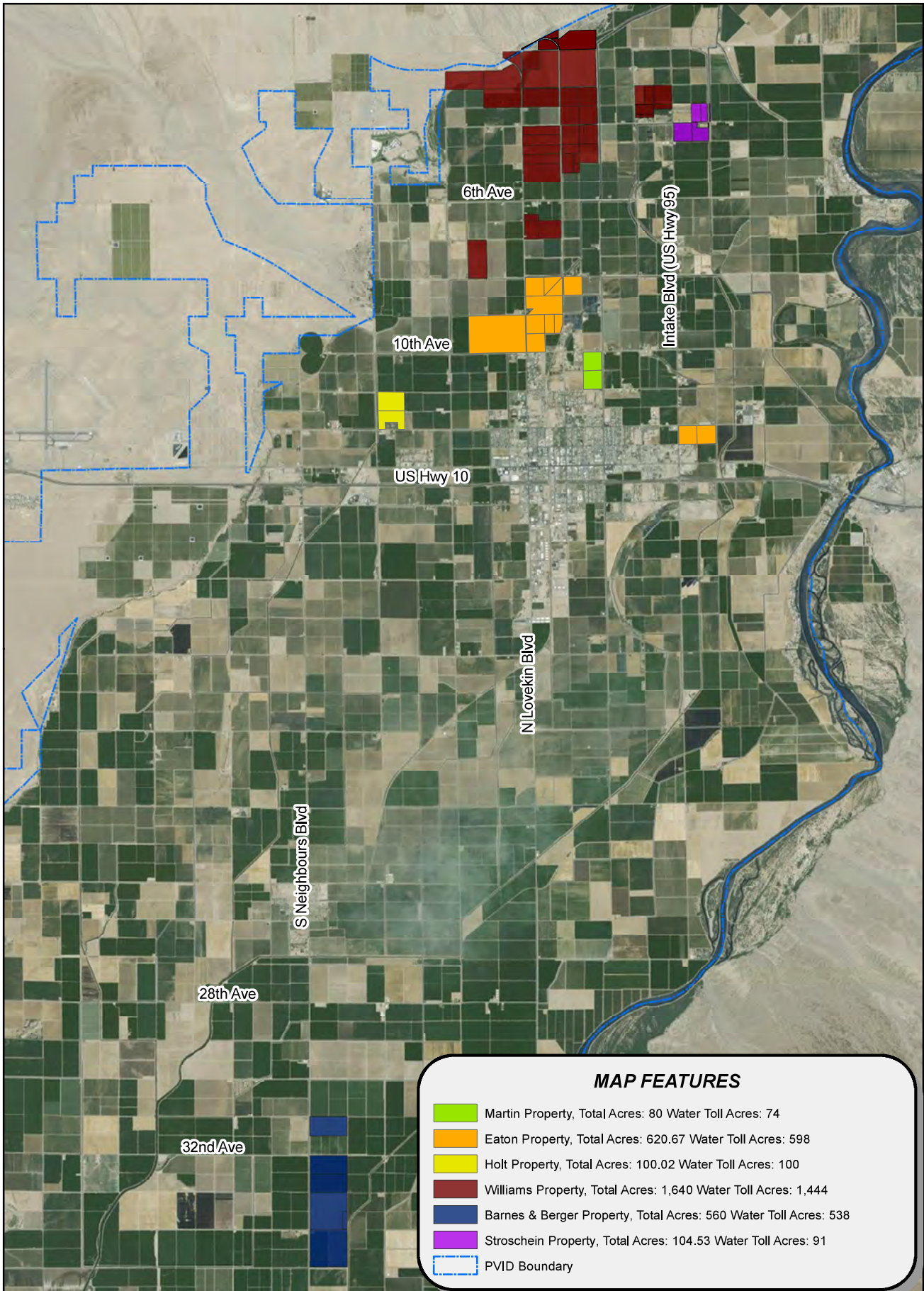

Note: This page is intentionally left blank.

Exhibit "C"

SUMMARY OF IRWD AGRICULTURAL LAND LEASES AND AGREEMENTS

Property	Gross Acres	Water Toll Acres	Agreement Type	Lessee/ Contract Farmer	Leasing Start Date	Current Lease End Date	Revenue
Jackson Ranch	883	NA	Agricultural Lease	Adee Honey Farms	5/15/2014	5/14/2025	Rent per acre (883 acres) Water cost per AF (up to 235 AF)
Eaton	621	598	Agricultural Lease	Van Dyke Farms Inc.	9/1/2016	8/31/2027	Rent per farmed acre (varies) Water Toll per farmed acre (varies)
Stroschein	105	91	Agricultural Lease	Deconinck Farms	1/1/2018	12/31/2027	Rent per farmed acre (varies) Water Toll per farmed acre (varies)
Barnes-Berger ¹	556	538	Agricultural Lease	Barnes and Berger (Subtenant- Coxco LLC)	3/30/2016	12/31/2025	Rent per farmed acre (varies) Water Toll per farmed acre (varies)
Williams ²	1640	1444	Agricultural Lease	E&S Farming	11/1/2017	9/30/2024	Rent per farmed acre (varies) Water Toll per farmed acre (varies)
Holt	100	100	Management Agreement	Chairel Custom Hay Inc.	12/16/2016	NA	Payments for hay sold
Martin	80	74	Management Agreement	Coxco LLC	7/1/2016	NA	Payments for hay sold

¹ A sublease agreement was executed 10/18/2023 for Coxco LLC to sublease from Barnes-Berger.

² IRWD purchased the Williams property on 2/27/2017 and assumed the existing farming lease with E&S Farming. A new lease between IRWD and E&S Farming was executed 11/1/2017.

Note: This page is intentionally left blank.