

DAM SAFETY PROGRAM

Guidelines & Governance



**Irvine Ranch
Water District**

January 2025

IRVINE RANCH WATER DISTRICT

DAM SAFETY PROGRAM

GUIDELINES & GOVERNANCE



Jacob J. Moeder, Dam Safety Engineer



Kevin L. Burton, Executive Director of Technical Services

JANUARY 2025

TABLE OF CONTENTS

DAM SAFETY PROGRAM Guidelines & Governance

NUMBER	DESCRIPTION	DATE
00	Dam Safety Program Overview	January 2025
DSP Guidelines		
01	Training	May 2023
02	Vegetation and Animal Activity Management	January 2025
03	Seismic Monitoring	January 2025
04	Seepage & Piezometer Monitoring	January 2025
05	Inspection Reports & Annual Surveillance Reports	January 2025
06	Movement Monitoring	January 2025
07	Maintenance	January 2025
08	Emergency Preparedness and Planning	May 2023
09	Non-routine Dam Safety Activities	May 2023
10	Periodic Dam Safety Review (PDSR)	July 2023
11	Data Management	January 2025
Emergency Action Plans & Response Plans		
EAP - 1	San Joaquin Dam Emergency Action Plan	-
EAP - 2	Sand Canyon Dam Emergency Action Plan	-
EAP - 3	Syphon Dam Emergency Action Plan	-
EAP - 4	Rattlesnake Dam Emergency Action Plan	-
EAP - 5	Santiago Creek Dam Emergency Action Plan	-
RP - 1	Santiago Creek Dam Valve Replacement Plan	March 2020
Operational Considerations		
IRRM -1	Santiago Creek Dam Interim Risk Reduction Measure	February 2020
IRRM -2	Rattlesnake Dam Interim Risk Reduction Measure	September 2024

1.0 Purpose

The purpose of this document is to provide an overview of Irvine Ranch Water District’s (IRWD’s) Risk Informed Decision Making (RIDM) based Dam Safety Program (DSP).

2.0 Introduction

This document summarizes the overall framework, including principles and guidelines for IRWD’s risk informed dam safety program and its portfolio of dams. IRWD currently owns and operates five large dams¹ and reservoirs as key components of its water supply/delivery system. IRWD also owns and operates a small concrete dam that is completely filled with sediment. The dams are summarized in Table 1 below.

Dam and Reservoir	Originally Constructed	Dam Height (ft)	Reservoir Storage (ac-ft)
Santiago Creek ²	1933	136	24,000
San Joaquin	1966	224	3,036
Sand Canyon	1942	58	768
Syphon	1949	59	578
Rattlesnake	1960	79	1,480
Harding Canyon ³	1900 (circa)	37	23

² Reservoir storage is to spillway crest and without flashboards installed.

³ The reservoir is completely filled with sediment, but at one point stored up to 23 acre-feet of native runoff.

The five large earthen embankment dams are regulated by the California Department of Water Resources, Division of Safety of Dams (DSOD). Each of the dams have been classified Extremely High Hazard by DSOD. The Extremely High Hazard designation is the result of DSOD’s determination that there are more than 1,000 residents within the estimated sunny day failure inundation limits below each dam.

The risk informed dam safety program summarized in this document provides a rigorous, systematic, and thorough framework that improves the quality of, and support for, dam safety decisions. The added benefit of the risk informed program is its ability to be scaled to the decision-making needs at IRWD. For example, when risks are relatively straight forward, a low level of effort may be suitable for IRWD to make an informed decision. In some instances, an identified risk that may require a significant cost to mitigate, or that significantly impacts IRWD’s ability to store and deliver water, may be addressed with much more rigorous risk estimating methods. More rigorous risk estimating methods, applied in combination with results from investigations and engineering analyses, can reduce uncertainty and increase IRWD’s confidence that corrective actions to reduce risk (e.g., dam modifications) are justified – or not. Overall, this system provides IRWD with critical information needed to proactively understand the condition of its dams, maintain an appropriate level of safety based on estimated risks, prioritize dam safety actions, and engage with the DSOD regulatory process.

¹ International Commission on Large Dams (ICOLD) defines a large dam as a dam having a height of 50-ft or more.

Dam Safety Program Overview

A risk informed dam safety program is grounded in identification of potential failure modes (PFMs) that could occur at each dam. The PFMs are tailored to a dam’s specific configuration along with the geologic and natural hazard setting of the dam and reservoir. Once PFMs are identified and described, the application of risk as a fundamental basis requires execution of three distinct components:

- Risk analysis
- Risk assessment
- Risk management

These components and their relationship to one another are illustrated on Figure 1.

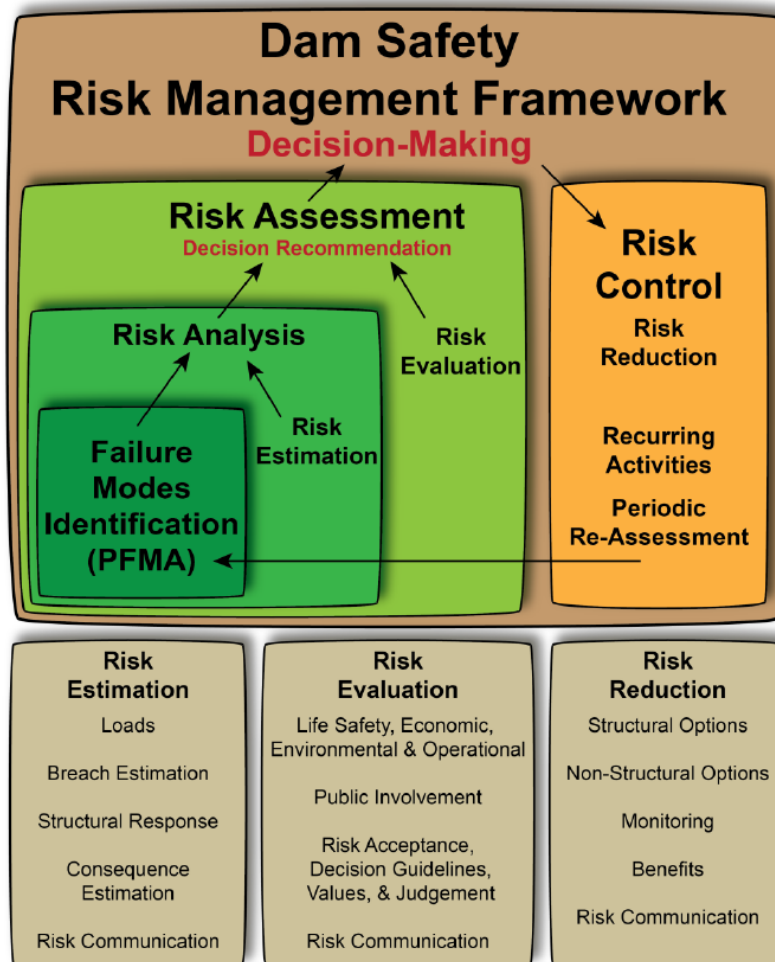

Figure 1: Dam Safety Risk Management Framework (FEMA 2015)

For risk analysis, the key activity is risk estimation. For risk assessment, the key activity is risk evaluation; a qualitative or quantitative description of the nature, magnitude, and likelihood of the adverse effects associated with a hazard. A risk evaluation under this program may include not only estimates of risk, but development of risk descriptions, identification of risk management options, economic and other evaluations, and estimates of changes in risk

attributable to the management options that are identified (FEMA, 2015). When risks are deemed unacceptable, decision-making is used to guide selection and implementation of risk reduction measures.

Estimating risk involves evaluation of three components as expressed in the following relationship:

$$\text{Risk} = \text{Probability of the loading} * \text{Probability of failure given the loading} * \text{Consequences given failure}$$

Risk: As shown above, risk is the product of the likelihood of the dam or appurtenant structure being loaded, adverse structural performance (e.g., dam failure) and the magnitude of the resulting consequences. Dam failure risk is measured in terms of lives per year.

Probability of the loading: The loading probability is estimated considering factors such as (1) reservoir operations and how often the reservoir reaches certain elevations, and (2) the size and frequency of natural hazard events such as floods and earthquakes. The annual probability of the loading event occurring is measured in units of per year.

Probability of failure given the loading: This is the conditional probability of failure given that the loading occurs and is sometimes referred to as the system response probability.

Consequences given failure: For IRWD's dam safety risk, consequences refer to life loss given failure occurs. Consequences may also include economic or environmental consequences. Consequences are incremental, meaning that dam failure life loss does not include life loss from non-breach events such as floods with large discharges.

Risk estimates reflect the condition of the dam or appurtenant structure being analyzed at a snapshot in time. These conditions can and will likely change over time, requiring periodic updates to the risk analysis. Likewise, the life loss consequences of a dam failure may also change as development occurs within potential dam failure inundation areas.

3.0 Guiding Principles

IRWD developed the following guiding principles for the risk informed dam safety program:

- Prioritize public safety and earn the public's trust by developing and implementing a state-of-the-art Dam Safety Program.
- Enhance the clarity and transparency of IRWD's Dam Safety Program with IRWD's customers and the community.
- Establish "Risk Informed Decision Making" strategies and guidelines for dam and reservoir management consistent with industry best practices that maximize safety and water supply reliability.
- Ensure that IRWD's dams achieve and maintain the highest condition rating issued by DSOD.

- Prioritize dam safety through dam and reservoir facility monitoring, inspection, maintenance, and risk reduction as appropriate.
- Establish IRWD as a leader in Dam Safety Programs.

3.1 Additional Objectives

The risk informed Dam Safety Program also serves the following key purposes:

- To establish a supportive and resilient culture of dam safety within all IRWD programs, management levels, and staff including IRWD's Board of Directors.
- To achieve an appropriate level of public safety through ongoing, periodic, and one-time program activities, including, periodic dam inspections and evaluations, surveillance, instrumentation monitoring, risk analyses, risk reduction activities (e.g., dam modifications), and dam emergency action plans with inundation maps. IRWD will take actions to mitigate/reduce risks commensurate with the identified risks within its dam portfolio.
- To develop and implement appropriate communication strategies within IRWD, with DSOD, and with other community stakeholders (e.g., fire and police departments) regarding the safety of IRWD's dams and actions that are being taken to achieve a tolerable level of risk.

4.0 Dam Safety Program Process

IRWD's DSP consists of routine and non-routine dam safety activities. The activities are shown in Figure 1 below.

Dam Safety Program Overview

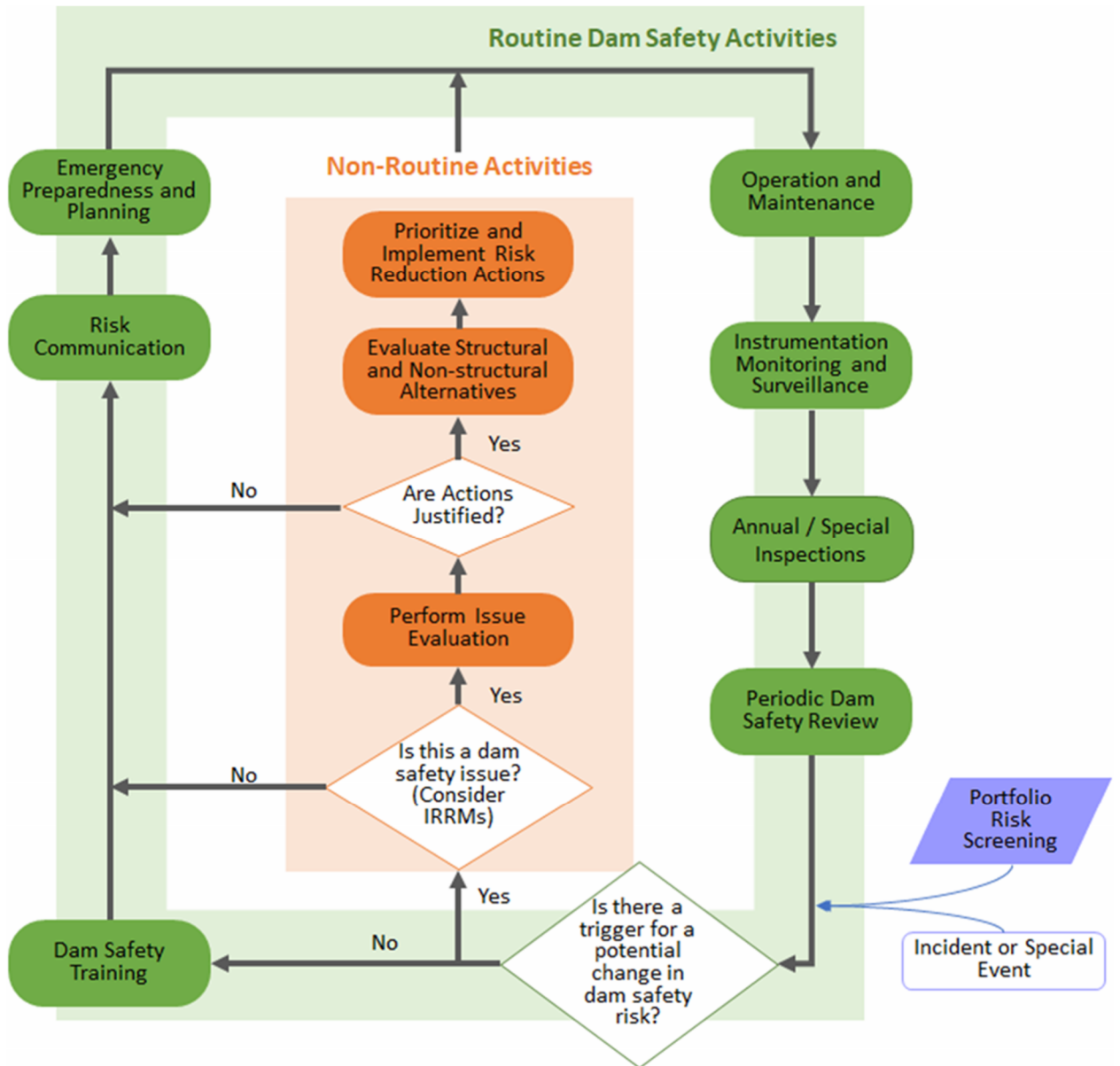

Figure 2: Routine and Non-routine dam safety activities.

The routine dam safety activities are implemented to continuously monitor dam performance and manage dam safety risks. They include operation and maintenance, surveillance and monitoring, different types of inspections, periodic dam safety reviews (PDSRs), dam safety training, risk communication and emergency preparedness. The order or position of the routine recurring dam safety activities on the outer loop (green) is not intended to be chronological because each of the recurring activities has its own timing. PDSRs include risk assessments of existing or any newly identified PFMs to re-evaluate risk using the most up to date information on loadings (hydrologic and seismic), dam performance and downstream consequences. The

Dam Safety Program uses risk to inform activities at individual dams and to prioritize actions across the portfolio.

Non-routine activities will be implemented to address a potential dam safety issue or specific concern. These activities include evaluating the need for interim risk reduction measures, issue evaluation(s), dam safety modification alternatives evaluation and design, and implementation of selected risk reduction measures. On an infrequent basis, dam safety emergencies may require emergency response that also triggers non-routine activities. The Dam Safety Program uses risk to make decisions about the severity of the situation and the urgency of actions, to select the recommended course of action, and to guide their implementation.

5.0 IRWD and DSOD Responsibilities

As the owner, IRWD is responsible for the safety of its dams and appurtenant structures. In this role, IRWD has established and implements a Dam Safety Program that manages the risks of its dams including training of staff in maintenance, operation, and safety of the dams; performing routine operation and maintenance activities; completing routine surveillance and monitoring; performing periodic dam safety inspections in accordance with industry best practices; analyzing the safety/risks of each dam and reservoir; mitigating unacceptable risks; developing and exercising dam Emergency Action Plans with inundation maps; and communicating with all IRWD stakeholders.

As the regulator for the safety of dams in California, DSOD is responsible for providing regulatory oversight of IRWD's Dam Safety Program, and conducting state inspections of IRWD dams. DSOD may also perform independent dam safety related analyses (e.g., seismic) and evaluation of IRWD's dams and impose operational restrictions on reservoir storage levels if deemed necessary to protect the life and property of potentially impacted downstream residents. DSOD also reviews and permits the investigation, design, and construction of modifications of IRWD's dams. DSOD has provided notice to all dam owners under its jurisdiction that it is in the process of adopting risk-informed decision making processes within its Dam Safety Program. DSOD intends on utilizing RIDM to prioritize the comprehensive re-evaluation of dams in the state of California and is not intended to be used as criteria for design.

6.0 Organizational Structure, Roles, and Responsibilities

IRWD is comprised of several departments that report to the General Manager under the direction of the Board of Directors (Board). Of these departments, the Technical Services and Operations departments carry primary responsibilities related to dam safety. This section outlines the responsibilities for each level and organizational group at IRWD that has a role in assuring dam safety.

6.1 Board

IRWD's Board governs the program and is responsible for policy and approvals in excess of staff's authority. Specifically, the Board:

- Has general knowledge of IRWD dams, the Dam Safety Program, risks, benefits and liabilities posed by IRWD dams, and supports organization-wide dam safety philosophy.
- Gives full consideration of dam safety project funding needs.
- Reviews and approves major dam safety and dam risk reduction projects.

6.2 General Manager

The General Manager oversees the entire IRWD and assigns the primary responsibility for the Dam Safety Program to the Technical Services Department. Specifically, the General Manager:

- Has specific knowledge of IRWD dams, the Dam Safety Program, risks, benefits and liabilities posed by IRWD dams.
- Actively promotes the District's organization-wide dam safety philosophy.

6.3 Executive Director of Technical Services

The Executive Director of Technical Services reports to the General Manager and provides oversight of the Dam Safety Program. Specifically, the Executive Director of Technical Services:

- Has specific knowledge of dams and their risk.
- Has frequent communication with the Dam Safety Engineer.
- Champions dam safety within IRWD and stakeholder community.
- Ensures the Dam Safety Program has adequate staffing.
- Promotes a culture of dam safety throughout the entire organization.
- Ensures the program has a positive working relationship with DSOD and CalOES.
- Identifies the need for and reviews dam safety processes, procedures, and guidelines.
- Supports dam safety in the organization's strategic plans, goals, and budgeting.
- Receives the Dam Safety Engineer's annual report and briefing, annual work plan, and five-year capital investment plan.
- Evaluates and recommends to the IRWD Board any proposed non-routine projects at dams (e.g., issue evaluation studies, investigations, analyses, and/or dam modifications) and major routine activities (e.g., significant maintenance projects) in accordance with IRWD's procurement procedures.
- Provides program quality assurance and governance including;
 - Assures that engineering designs and construction are adequate.
 - Ensures independent program reviews are conducted periodically and that recommendations are implemented.

- Incorporates dam safety roles and responsibilities in position descriptions and staff performance evaluations.

6.4 Dam Safety Engineer

The Dam Safety Program is led by the Dam Safety Engineer. The Dam Safety Engineer has overall responsibility for implementing and maintaining the overall Dam Safety Program processes.

The Dam Safety Engineer:

- Reports to the Executive Director of Technical Services.
- Implements the Dam Safety Program routine and non-routine activities.
- Responds promptly and effectively to dam incidents and ensures that incident lessons are discovered and learned.
- Maintains and manages the dam portfolio risks and any necessary risk mitigation projects.
- Develops, in collaboration with Operations, contingency plans to ensure reliability of dam operations.
- Engages with IRWD decision makers as needed and provides decision support for decisions that might include implementing responses to emerging dam safety incidents, implementing interim risk reduction measures (IRRM), and implementing permanent actions to reduce risk.
- Establishes budgetary requirements to ensure funding is available for implementation of routine and non-routine dam safety activities.
- Produces an annual dam safety report and updates a five-year Dam Safety Program work plan.
- Stays current with dam safety technological improvements and regulatory requirements.
- Ensures regulatory requirements for all facilities are satisfied.
- Develops processes, procedures and guidelines for the Dam Safety Program as a whole and for individual program areas.
- Establishes and maintains Dam Safety Program specific quality control processes.

The Dam Safety Engineer leads and manages program staff or consultants that perform program tasks and projects, including:

- Recurring routine dam safety activities (dam records, instrumentation and monitoring, annual inspections, PDSRs, Emergency Action Plans, etc.).
- Non-routine activities (issue evaluations, field programs, analyses, alternatives analysis, modification designs and construction, etc.)
- Planning and executing the dam safety training program (customized for all levels of the organization).

To perform the duties and responsibilities of the position, the Dam Safety Engineer may rely on staff or highly qualified consultants for assistance with specific technical areas

including, but not limited to, structural engineering, seismology, geotechnical engineering, geology, hydrology, hydraulics, emergency management, instrumentation, and risk informed decision making. The Dam Safety Engineer coordinates and communicates internally and externally by:

- Engaging internally on a regular basis with Operations
- Engaging externally with DSOD and Cal-OES, as needed
- Supporting public safety and security at dams and personnel safety
- Representing IRWD in state and dam safety association meetings and events

6.5 Program Staff

IRWD staff will be assigned, as needed, to assist the Dam Safety Engineer in performing Dam Safety Program functions and tasks in the areas of:

- Dam data and record keeping
- Regulatory compliance
- Dam inspections and DSOD inspections
- Dam surveillance, instrumentation and monitoring
- Dam safety risk analyses
- Risk assessment
- Non-routine activities including field investigations, analyses, and dam modifications
- Emergency management including Emergency Action Plans and inundation maps.

Because of workload or need for specialty skills, knowledge, and expertise, program tasks and projects may be contracted out to qualified consultants; however, responsibility for the program activities shall always be retained and managed by the Dam Safety Engineer.

7.0 Guidelines for Routine Dam Safety Activities

IRWD has developed guidelines for dam safety activities identified in the Figure 2 process flow chart. The guidelines describe the activities, the frequency of activities, and responsible parties. Below in Table 1 is a list of the routine and non-routine dam safety activities and the corresponding guidelines contained in IRWD's Dam Safety Program.

Dam Safety Program Overview

Table 1: Guidelines for Routine Dam Safety Activities	
Activity	Related Guideline/Plan
Dam Safety Training	<ul style="list-style-type: none"> DSP Guideline No. 1 – Training
Emergency Preparedness and Planning	<ul style="list-style-type: none"> DSP Guideline No. 8 – Emergency Preparedness and Planning Emergency Action Plan – San Joaquin Dam Emergency Action Plan – Sand Canyon Dam Emergency Action Plan – Syphon Dam Emergency Action Plan – Rattlesnake Dam Emergency Action Plan – Santiago Creek Dam Santiago Reservoir Valve Replacement Plan, March 12, 2019
Operations and Maintenance	<ul style="list-style-type: none"> DSP Guideline No. 2 – Vegetation and Animal Activity Management DSP Guideline No. 7 – Maintenance Operational Considerations Related to Dam Safety DSP Guideline No. 11 – Data Management
Instrumentation Monitoring and Surveillance	<ul style="list-style-type: none"> DSP Guideline No. 3 – Seismic Monitoring DSP Guideline No. 4 – Seepage and Piezometer Monitoring DSP Guideline No. 6 – Movement Monitoring
Annual / Special Inspections	<ul style="list-style-type: none"> DSP Guideline No. 5 – Inspection Reports & Annual Surveillance Reports
Periodic Dam Safety Review	<ul style="list-style-type: none"> DSP Guideline No. 10 – Periodic Dam Safety Review (PDSR)
Non-routine Activities	<ul style="list-style-type: none"> DSP Guideline No. 9 – Non-routine Dam Safety Activity

8.0 References

8.1 HDR, “Dam Safety Program Framework”, September 15, 2021

Dam Safety Program Guideline No. 1 - Training

1.0 Purpose

The purpose of this guideline is to ensure that Irvine Ranch Water District (IRWD) staff that have an active role in dam safety are adequately trained for the functions they perform, that new employees are properly trained, and that staff continue to remain abreast of current practices and procedures in the dam industry to further enrich IRWD's dam safety program (DSP).

2.0 Definitions

Below is a summary of terms used herein that are used in this guideline.

Training - The act of teaching an individual on a particular topic so that the individual may garner a particular skill that they may or may not already possess.

Continuing Education - The act of refreshing on existing knowledge or expanding an individual's knowledge in a particular field or topic.

3.0 General Guidelines

Staff involved with IRWD's DSP shall receive training and be encouraged to pursue continuing education in the field of dam safety. Below in Table 1 is a summary of training topics, the positions at IRWD that should receive training, and the frequency of the training.

Table 1: Training Schedule			
Training Topic	Description of Activity	Position(s) to Receive Training	Frequency
Piezometers	Procedure for collecting, interpreting, troubleshooting, and distributing data	<ul style="list-style-type: none"> • Recycled Water Operations Supervisor • Operations staff in Water Operations Group 	At least once in first year of employment and when equipment or procedures change and as needed
	Procedure for monitoring piezometer data (e.g., frequency of review, expected readings, readings that require a response, etc)	<ul style="list-style-type: none"> • Recycled Water Operations Supervisor • Operations staff in Recycled Water Operations Group • Engineering staff in Dams & Storage Group 	At least once in first year of employment and as needed thereafter
Seepage	Procedure for collecting, interpreting, troubleshooting, and distributing data	<ul style="list-style-type: none"> • Recycled Water Operations Supervisor • Operations staff in Recycled Water Operations Group 	At least once in first year of employment and when equipment or procedures change and as needed

Dam Safety Program Guideline No. 1 - Training

Table 1: Training Schedule			
Training Topic	Description of Activity	Position(s) to Receive Training	Frequency
	Procedure for monitoring seepage data (e.g., frequency of review, expected readings, readings that require a response, etc)	<ul style="list-style-type: none"> • Recycled Water Operations Supervisor • Operations staff in Recycled Water Operations Group • Engineering staff in Dams & Storage Group 	At least once in first year of employment and as needed thereafter
Daily/Weekly Reservoir Patrols	This item generally includes routine general inspection of reservoir, inspection reports, equipment, security, collection of data, and performance of reservoir	<ul style="list-style-type: none"> • Recycled Water Operations staff 	At least once in first six months of employment and as needed thereafter
Emergency Action Plans (EAP)	Review of EAP, notification tree, and location of EAP	<ul style="list-style-type: none"> • EAP Plan Holders • Water Operations staff • Dams & Storage engineering staff • Standby staff • Emergency Operation Team Members¹ 	Once annually
Dam Safety Program Guidelines	Review DSP Guidelines	<ul style="list-style-type: none"> • IRWD staff involved with subject of specific guideline 	As needed
Inspection Reports	Review of components of dam and how to complete Inspect Reports	<ul style="list-style-type: none"> • Water Operations Staff 	At least once in first year of employment and as needed thereafter

¹IRWD maintains an Emergency Operations Plan (EOP) that is separate from the EAP. The EOP guides staff internal to IRWD to effectively manage response and recovery.

The goal of the training is for the employee to acquire or refresh on the skills necessary to perform the employee’s job duties and to ensure overlap in knowledge base.

Operators in the water group, or cross training in the group, shall be trained in how to collect, report, and interpret data from all types of piezometers, seismic monitoring equipment, flow meters, and level sensors utilized at IRWD’s dams. The training shall also include identifying faulty reads, troubleshooting, and process for repairing nonfunctional instruments.

In addition to the training requirements, staff involved with the DSP should pursue continuing education to remain abreast of current trends, practices, and concerns in the dam safety industry. Staff are encouraged to attend webinars, technical seminars, and conferences to remain informed. Part of continuing education is remaining informed as to the dam safety risks for IRWD’s dams and the District’s approach to managing the risks. IRWD’s Risk Informed Decision Making (RIDM) based DSP includes a perpetual cycle of risk assessment and re-

prioritization of action items geared towards managing risks. On a recurring basis, and as significant changes are identified in the risk assessment of IRWD’s dams, the Dam Safety Engineer will provide updates to engineering and operations staff of the perceived risks in IRWD’s portfolio of dams. Understanding risks with each dam, and how the risks are managed, will promote awareness of specific areas of concern (e.g., seepage, movement, etc) for the betterment of IRWD’s DSP and public safety.

A minimum of four (4) staff (two (2) from Engineering and two (2) from Operations) should maintain a membership to a professional dam organization including, but not limited to, Association of State Dam Safety Officials (ASDSO), United States Society of Dams (USSD), or International Commission of Large Dams (ICOLD).

4.0 Responsibility

Various staff are responsible for identifying and ensuring the completion of training. Table 2 summarizes the responsibility of staff for identifying training and continuing education opportunities.

Table 2: Responsibilities for Identifying and Ensuring Completion of Training Opportunities	
Description of Responsibility	Responsible Party
Maintain Training and Continuing Education Log	Dam Safety Engineer
Identify and encourage appropriate staff to pursue continuing education	Water Operations Manager, Recycled Water Supervisor, and Dam Safety Engineer
Ensure that new Operators in the Recycled Water Operations group undergo instrumentation and monitoring training	Water Operations Manager, Recycled Water Supervisor
Inform appropriate staff of identified dam safety risks	Dam Safety Engineer
Ensure appropriate staff are trained on EAP for each dam	Director of Safety and Security

Maintaining records is an important component of IRWD’s DSP. On a routine basis, the Dam Safety Engineer, Water Operations Manager, and Recycled Water Supervisor will collaborate on identifying staff that require training and who should be encouraged to pursue continuing education.

5.0 References

- 5.1 IRWD Policy No. 23 – Education and Training
- 5.2 IRWD Emergency Operations Plan, September 2020
- 5.3 ASDSO Website: <https://damsafety.org/>
 - 5.3.1 Dam Owner Academy: Dams 101 https://youtu.be/0H_TVGP5ik
- 5.4 USSD Website: <https://www.usstdams.org/>
- 5.5 ICOLD Website: <https://cda.ca/international/icold>

1.0 Purpose

The purpose of this document is to provide guidance for monitoring, managing, and repairing damage from vegetation and animal activity at Irvine Ranch Water District's (IRWD) dams.

2.0 Definitions

Below is a summary of terms used herein that are related to IRWD's Dam Safety Program (DSP).

Abutment - The contact between the sides of the dam and the natural ground that the dam butts up against.

Landscape Contractor - Contractor hired by IRWD to maintain landscape that is managed by IRWD's Landscape Manager.

Downstream Slope of Dam - The face of dam that is located away from the reservoir water.

Earthen Embankment - A dam constructed of compacted natural soil fill materials that are selected to retain water behind the dam while minimizing seepage.

IRWD's Landscape Manager - IRWD staff responsible for ensuring irrigated and landscaped areas at IRWD's facilities, including IRWD's dams, are properly maintained with the use of internal or external staff.

Rodent Control Contractor - Contractor hired by IRWD, and managed by IRWD's Landscape Manager, that monitors, maintains, and controls animal activity.

Seepage - The flow of water from the body of stored water through the embankment, abutments, or foundation of the dam.

Upstream Slope of Dam - Reservoir or lake side of dam.

3.0 General Guidelines

3.1 Vegetation

IRWD's five earthen embankments have different surface treatments on the downstream and upstream slope of the dam. Surfaces having soil will have a propensity for vegetation growth and require more frequent vegetation clearing than impervious surfaces. Below in Table 1 is a summary of the surfaces at each of IRWD's dams.

**Dam Safety Program
Guideline No. 2
Vegetation and Animal Activity Management**

Table 1: Summary of Finished Surfaces at IRWD's Dams				
Dam	Upstream	Dam Crest	Downstream	Spillway
San Joaquin	Compacted impervious earth lining – AC pavement	AC pavement	Rolled random rock	Overflow vault and Reinforced Concrete Pipe through embankment
Sand Canyon	AC pavement	AC pavement	Compact pervious material, vegetated	Open rectangular channel that is a combination of concrete walls and sandstone bedrock that is filled with dental concrete
Syphon	Compacted fill, vegetated	Compacted fill	Compacted fill, vegetated	Concrete lined trapezoidal channel
Rattlesnake	AC pavement	AC pavement	Compacted fill, vegetated	Concrete and gunite lined trapezoidal channel
Santiago Creek	Concrete lined	Compacted impervious fill	Compacted pervious fill, vegetated	Concrete line rectangular channel
Harding Canyon	Concrete with bentonite liner on upstream side of dam	Concrete	Concrete	Concrete notch in dam crest

Vegetation growth on dams and related appurtenances is a dam safety concern as it could lead to, but is not limited to, the following:

- Trees could be uprooted and produce large voids that reduce the cross section of the dam.
- Roots of vegetation, particularly woody vegetation, could decay over time thereby creating seepage paths and lead to internal erosion.
- Vegetation on the dams could hinder visual inspections.
- Vegetation in spillways could reduce hydraulic capacity, damage the spillway structure, and undermine the foundation.
- Vegetation could hide animal burrowing activity.
- Vegetation could serve as a food source to animals that pose a dam safety concern.

**Dam Safety Program
Guideline No. 2
Vegetation and Animal Activity Management**

- Roots can wedge into cracks and joints at key locations, such as along abutments and toe of embankment and thereby increase the potential exposure to leakage.
- Roots could impact subdrain systems and outlet conduits.

Given the dam safety concern with vegetation growth on dams, IRWD shall routinely inspect, manage, and remove the vegetation on the upstream and downstream side of the dam and in the spillway.

IRWD maintains Landscape Maintenance Specifications that describe the scope, service level and frequency at major IRWD facilities. The specifications include requirements for IRWD’s dams such as the areas to maintain, frequency of maintenance, growth tolerance, and special requirements. To enhance awareness and further ensure the vegetation throughout the dam is thoroughly managed, staff should follow a process for reviewing the vegetation maintenance and notifying appropriate staff when the maintenance is complete. Figure 1 describes the vegetation management notification and review process for IRWD’s dams.

3.2 Animal Activity

Various animals thrive in Southern California, some of which may be a concern for earthen embankments. Animal activity that may impact dam safety include, but are not limited to, creating animal burrows, ruts, nests, and erosion. Table 2 below summarizes the animals of concern that are known to exist in the Southern California region that have the potential for inhabiting IRWD’s earthen embankments.

Table 2: Summary of Animals on Earthen Dams		
Species	Type of Activity	Threat to Dams
Pocket Gopher - Botta (Thomomys botta)	Dig burrows in dam.	Burrows can lead to internal erosion and structural integrity losses in the dam. Presence of gophers can lead to badger activity.
North American Badgers	Dig in pursuit of prey and digging is highly destructive compared to gophers. Can dig large burrows from 5-30 feet long.	Badgers prey on gophers and will exacerbate internal and external erosion in earthen dams by enlarging existing burrows for gophers, squirrels, and other animals that may inhabit the dam.
Ground Squirrel - California (Spermophilus beecheyi)	Dig burrows in dam.	Burrows can lead to internal erosion and structural integrity losses in the dam. Presence of gophers can lead to badger activity.
Crayfish	Dig burrows in dam. Generally found in fresh water along shorelines.	Burrows can lead to internal erosion and structural integrity losses in the dam.

Dam Safety Program Guideline No. 2 Vegetation and Animal Activity Management

Coyote	Build dens and dig in pursuit of prey.	Digging can lead to loss of structural integrity.
Voles (meadow mice or field mice)	Dig burrows in dam.	Burrows can lead to internal erosion and structural integrity losses in the dam.
Gray Fox (<i>Urocyon cinereoargenteus</i>)	Dig in pursuit of prey.	Digging can lead to loss of structural integrity.
Canada Goose (<i>Branta canadensis</i>)	Nest near water, which could occur at earthen dam and cause external erosion.	Nest building can lead to external erosion.
Ants	Build complex series of tunnels.	Complex network of tunnels can exacerbate existing cracks and can soften the embankment and impact the structural integrity.

Additional information on the above listed species, including photos, description of food sources, behavior, and tips for the field can be obtained by reviewing the Federal Emergency Management Agency (FEMA) 473 Impacts of Animals on Earthen Dams. Animal burrowing is the primary dam safety concern. Figure 2 provides a cross section view of a sample earthen dam that shows potential animal burrowing activity in relation to possible water level through the dam. The figure illustrates how animal activity can reduce the cross section of the dam and present a dam safety concern. As such, it is critically important to control animal activity and protect the condition of the dam.

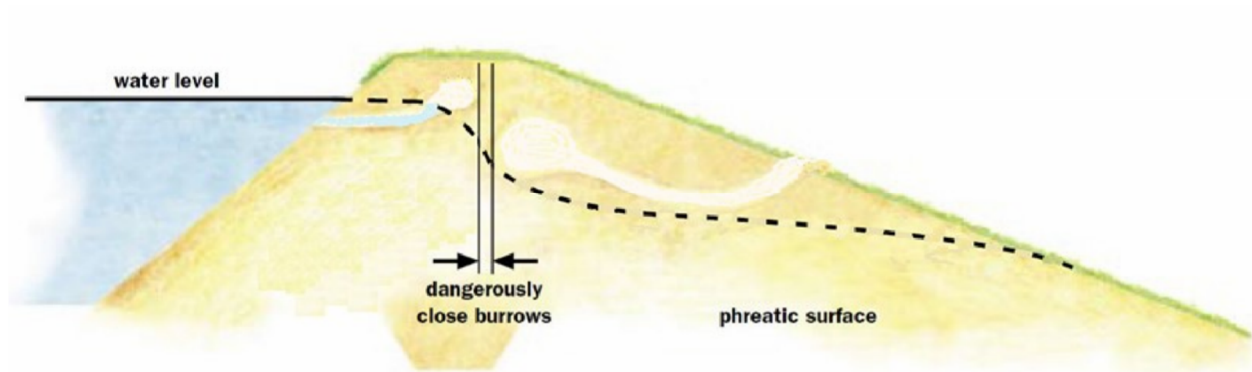

Figure 2: Section View of Dam with Animal Burrowing Activity (FEMA 473).

3.3 Repair of Damage from Vegetation and Animal Activity

FEMA 473 offers guidance on various types of repairs based on the level of impacts to the embankment. Table 3, which is based on FEMA 473, describes various repair

Dam Safety Program Guideline No. 2 Vegetation and Animal Activity Management

methods and responsible parties to carry out the repairs to the dam including the upstream slope, dam crest, downstream slope and spillway. It is important to determine if there are visual signs of embankment distress, such as cracks, settlement, or slumping, when considering an area for repair. If signs of embankment distress are present, the Dam Safety Engineer will review the condition of the embankment in collaboration with dam experts, as needed, to recommend a repair.

Table 3: Vegetation and Animal Burrowing Repair Methods and Responsible Parties

Description	Repair Method	Responsible Party
Loss of vegetation	Revegetate area.	Landscape Contractor, Landscape Manager
Embankment material loss (less than 6-inches deep ¹) from vegetation removal or animal activity	Place soil of similar type and compact by foot or with handheld equipment.	Rodent Control Contractor, Landscape Manager
Embankment material loss (6-inches deep or greater ¹) from vegetation removal without signs of embankment distress	Check for signs of embankment distress (e.g., cracking, slumping, depression, erosion, sinkholes, ruts, sloughing, slides, and scarps) in the area of material loss. If no signs of distress, place soil of similar type and compact using handheld or walk behind equipment. If signs of embankment distress, contact Dam Safety Engineer.	Construction Services, Engineering (if beyond Construction Services capabilities)
Embankment material loss (6-inches deep or greater ¹) from animal burrowing without signs of embankment distress	Check for signs of embankment distress (e.g., cracking, slumping) in the area of material loss. If no signs of distress, the burrows may be filled with impervious material or cementitious grout. "Mud-packing" may also be used to fill the entire burrow, which consists of placing piping in the burrow and placing a mixture 90% earth and 10% concrete, plus appropriate amount of water to promote flowability.	Construction Services
Embankment material loss from vegetation removal or animal activity with any signs of embankment distress	To be determined, based on condition assessment.	Dam Safety Engineer

Dam Safety Program Guideline No. 2 Vegetation and Animal Activity Management

Vegetation removed from impervious surfaces (e.g., concrete spillway, concrete liner, AC pavement)	For concrete surface, repairs shall be in accordance with United States Bureau of Reclamation Guide to Concrete Repair. For AC surfaces, repairs shall be in accordance with IRWD's General Technical Specifications.	Construction Services
--	---	-----------------------

¹Depth is measured perpendicular to surface.

4.0 Responsibility

Various staff are responsible for monitoring and controlling vegetation growth and animal activity. Table 4 summarizes the responsibilities of staff for managing vegetation and animal activity.

Table 4: Vegetation and Animal Activity Management Responsibilities		
Description of Responsibility	Responsible Party	Notes
Maintenance of IRWD's Landscape Maintenance Specifications	Facilities/Fleet Manager	Dam Safety Engineer shall be involved with updates related to dams
Document status of vegetation and animal activity in routine inspection reports	Operations staff	Refer to DSP Guideline No. 5, Inspection Reports & Annual Surveillance Reports, for details on inspection reports
Review and accept adequacy of vegetation management	Landscape Manager	
Notify IRWD staff when vegetation management is complete	Landscape Manager	Operations staff will document in routine inspection reports
Repair damage to embankment from vegetation or animal activity	See Table 3	Repairs shall be discussed with Dam Safety Engineer in advance of performing the work

5.0 Exhibits

Figure 1: Vegetation Management Notification and Review Process for IRWD's Dams

6.0 References

- 6.1 Technical Manual for Dam Owners, Impacts of Plants on Earthen Dams, FEMA 532, September 2005
- 6.2 Technical Manual for Dam Owners, Impacts of Animals on Earthen Dams, FEMA 473, September 2005

**Dam Safety Program
Guideline No. 2
Vegetation and Animal Activity Management**

- 6.3 Guide to Concrete Repair, Second Edition, August 2015, United States Bureau of Reclamation
- 6.4 Irvine Ranch Water District Construction Manual, General Technical Specifications, February 2024, or latest edition
- 6.5 Landscape Maintenance Specifications, Irvine Ranch Water District, March 11, 2021

Figure 1: Vegetation Management Notification and Review Process for IRWD's Dams

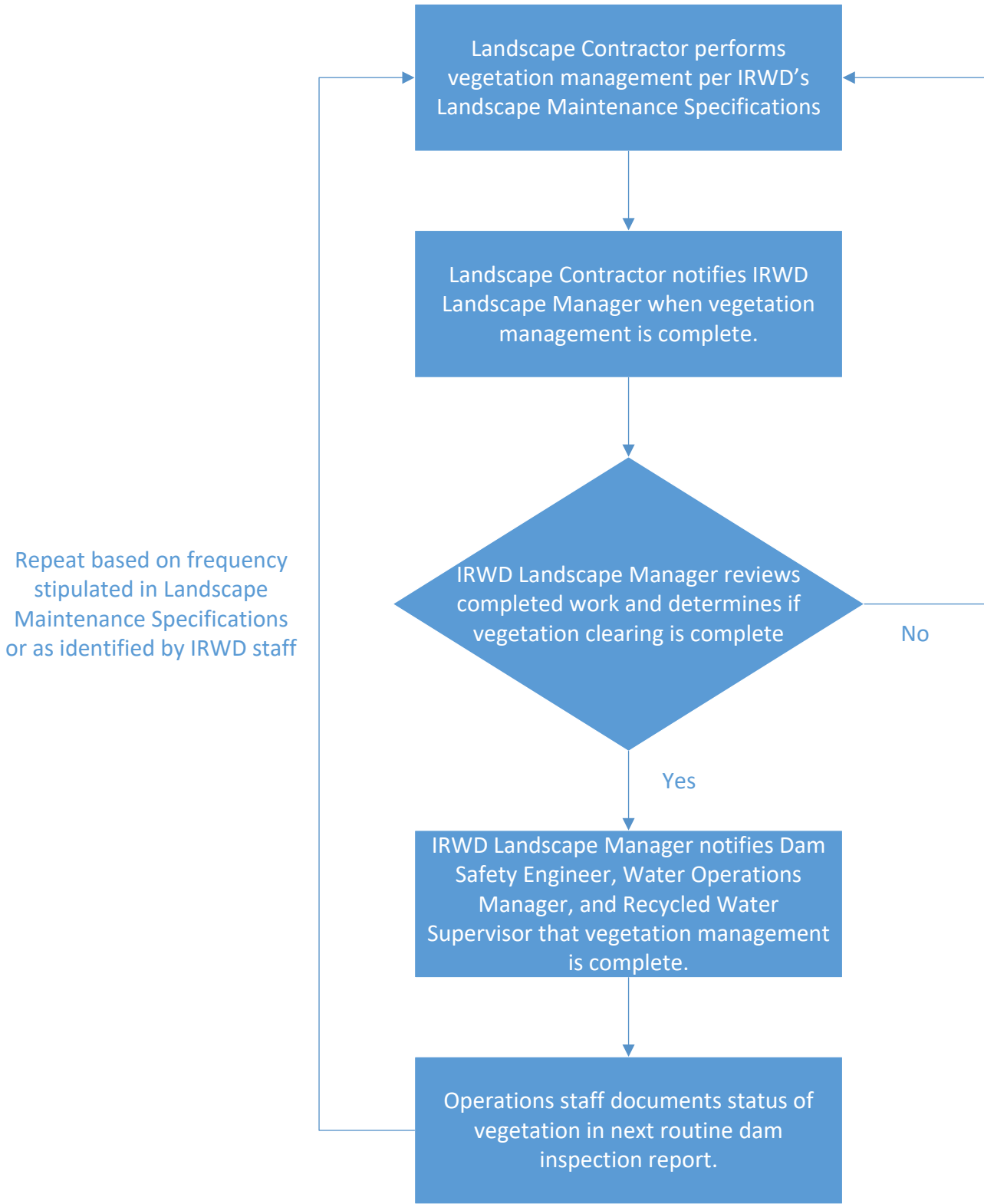

1.0 Purpose

The purpose of this document is to provide guidance for monitoring and responding to seismic events that may impact Irvine Ranch Water District's (IRWD) dams.

2.0 Definitions

Below is a summary of terms used herein that are related to this guideline.

Anatomy of an Earthquake:

Epicenter - the point on the surface directly above the focus of the earthquake.

Fault - a fracture in the rocks that make up the earth's crust and where movement between two surfaces occurs during an earthquake.

Fault scarp - small step or offset on the ground surface where one side of a fault has moved vertically with respect to the other.

Focus - also referred to as the hypocenter, is the point within the earth where the earthquake rupture starts.

Seismic waves - an elastic wave generated by an earthquake that travels in all directions.

Magnitude - the size, or amplitude, of seismic waves recorded by a seismograph that represents a measurement of energy released during an earthquake.

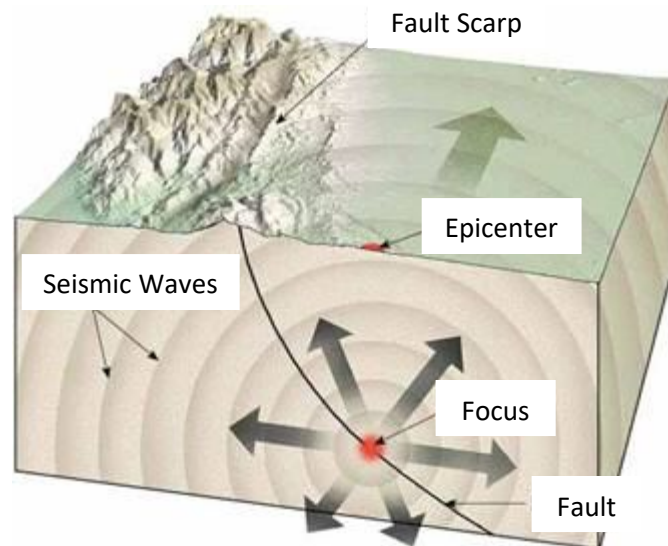

Figure 1: Anatomy of an earthquake.

ShakeCast - A USGS online post-earthquake situational awareness application that retrieves data from ShakeMap and distributes the data after a triggering event occurs.

ShakeMap - A USGS tool used to portray the extent of potential damage after an earthquake event occurs.

Response Plan Term:

Response – The initial start of the described action (e.g., starting to review seismic data, arriving to the field to conduct inspections or data gathering, etc.)

3.0 Background

Historically, the magnitude and starting point (focus) of the earthquake was the most common information available following an earthquake event. While the magnitude and starting point are useful information, they offer limited insight on perceived ground motion intensities and potential damage in the area of the event because the response can vary as seismic waves travel through rock and soil and travel varying distances. There are multiple examples where the most damage post a seismic event occurred farther away from the starting point, such as the 1971 Magnitude 6.7 San Fernando earthquake where the most damage occurred about 9 miles away from the epicenter.

ShakeMap is a tool developed by United States Geological Survey (USGS) that utilizes the network of seismic recording instruments to ground-truth the accelerations in the area of the seismic event to then project the perceived ground motion intensity and potential damage. ShakeMap has become the “go-to” way for understanding seismic activity.

DSOD monitors seismic activity in the area of all the jurisdictional dams in the state of California. Historically, they responded to earthquakes with a magnitude 5.0 or greater where the epicenter was located within 10 miles of a dam. However, DSOD recognized that a specific magnitude earthquake at a certain distance from a dam does not entirely correlate to what might be experienced at the dam of concern. This is largely because site geology can dampen or amplify ground acceleration from the seismic waves at unique dam sites. Now, DSOD uses a combination of data from ShakeCast, ShakeMap and site-specific geology to predict the response at each dam location. Below in Figure 2 is a sample ShakeMap display and legend.

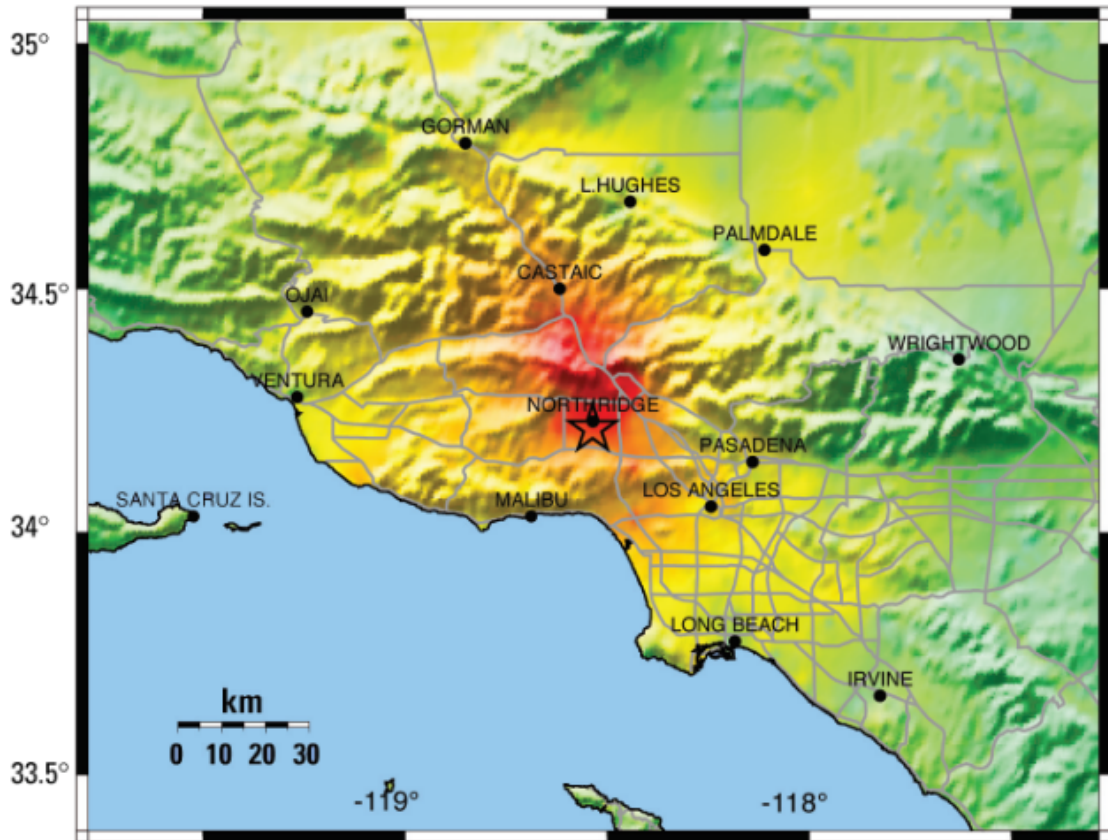

PERCEIVED SHAKING	Not felt	Weak	Light	Moderate	Strong	Very strong	Severe	Violent	Extreme
POTENTIAL DAMAGE	none	none	none	Very light	Light	Moderate	Moderate/Heavy	Heavy	Very Heavy
PEAK ACC.(%g)	<.17	.17-14	1.4-39	3.9-92	9.2-18	18-34	34-65	65-124	>124
PEAK VEL.(cm/s)	<0.1	0.1-1.1	1.1-3.4	3.4-8.1	8.1-16	16-31	31-60	60-116	>116
INSTRUMENTAL INTENSITY	I	II-III	IV	V	VI	VII	VIII	IX	X+

Figure 2: Example of earthquake intensity map and potential damage categories.

4.0 General Guidelines

IRWD owns, operates, and maintains six dams. Five of the dams are over 50-feet high and considered large as defined by the International Commission of Large Dams (ICOLD). The five large earthen embankments are regulated by the Division of Safety of Dams (DSOD). One of the six dams is Harding Canyon Dam and is located in the Santiago Canyon. Harding Canyon Dam is a concrete dam that is under 50-feet high, impounds a minimal amount of native runoff, and is not regulated by DSOD.

Seismic activity can impact a variety of structures including dams. The energy released from seismic events causes ground accelerations and can negatively impact IRWD's dams. Impacts may include, but are not limited to, deformation, cracks, exacerbate seepage, and liquefaction.

4.1 Seismic Activity Response Plan

Given the potential damage seismic events can cause, IRWD staff monitors seismic activity and responds if qualifying seismic events occur within a certain distance of IRWD’s dams. The responses include visual inspection, collecting piezometer data, collecting seepage flow data, and surveying the benchmarks on the dam. The purpose of the post-event response is to determine if there is a changed condition that requires further response. If there is a changed condition the Dam Safety Engineer shall be notified, and an appropriate response developed. Table 1 below describes the range of events and corresponding responses.

Table 1: Summary of Seismic Activity Response Plan	
Description	Response
Earthquake magnitude > 5.0 where the epicenter is within 50 miles of any of IRWD’s large dams	<p><u>Once immediately following the event</u></p> <ul style="list-style-type: none"> • Review ShakeMap and determine if Intensity and Potential Damage at IRWD’s dams is “V” / “Very Light” or greater. If so, then complete the following field responses. <ul style="list-style-type: none"> • Visually inspect dam. • Collect and evaluate piezometer data. • Collect and evaluate seepage flow data. • Survey benchmarks and evaluate amount of movement. • Communicate results of inspection to DSOD and coordinate DSOD inspection. <p><u>The field responses should be completed weekly (at a minimum) for four weeks following the event.</u></p>
Earthquake magnitude ≥ 4.0 where the epicenter is within 50 miles of any of IRWD’s large dams	<p><u>Once immediately following the event</u></p> <ul style="list-style-type: none"> • Review ShakeMap and determine if Intensity and Potential Damage at IRWD’s dams is “V” / “Very Light” or greater. If so, then <ul style="list-style-type: none"> • Visually inspect dam. • Collect and evaluate piezometer data. • Collect and evaluate seepage flow data.
Earthquake magnitude < 4.0 at any location	No response – conduct routine inspection and monitoring.

Following a seismic event that qualifies for a post-event inspection, staff shall complete the inspection forms included in DSP Guideline No. 5. The inspection report shall be reviewed by Water Operations staff and the Dam Safety Engineer. The review should include an assessment on the condition of the dam based on visual observations and collected data and a determination of the following.

- If there are changes in the collected data from historic readings
- If there are visual changes to the dam (e.g., surface cracks, local settlement, seepage, etc)
- If review of the post-event inspection warrants the input of a Dam Engineering Consultant
- If a dam safety issue exists

4.2 Seismic Activity Response Timeline

Staff's response time will vary based on the time of day and size of the event that occurs. The response time includes two levels of response including the initial data review and the following field response. The initial action is to review the seismic activity and determine if it requires additional responses per the guidelines. The second part of the response, if required, is to deploy resources to perform inspections and field data gathering. There is a natural variability in response time since during work hours IRWD has many resources in the area and outside normal work hours standby crews are called upon and, if needed, additional resources are called in that may not be immediately local. The below Table 2 summarizes the target response timelines.

Description	Data Review		Field Response	
	Normal Business Hours	Outside Business Hours	Normal Business Hours	Outside Business Hours
Earthquake magnitude > 5.0 where the epicenter is within 50 miles of any of IRWD's large dams	Within 1 hour of Event	Within 1 hour of Event	Within 1 hour of determining event requires a response	Within 2 hour of determining event requires a response
Earthquake magnitude ≥ 4.0 where the epicenter is within 50 miles of any of IRWD's large dams	Within 1 hour of Event	Within 2 hours of Event	Within 2 hours of determining event requires a response	Within 4 hours of determine event requires a response
Earthquake magnitude < 4.0 where the epicenter is within 50 miles of any of IRWD's large dams	N/A	N/A	N/A	N/A

4.3 USGS & Application-Based Monitoring

Earthquakes of varying magnitude occur daily. IRWD staff monitor seismic activity using United States Geological Survey (USGS) or applications available on devices such as QuakeFeed. Both the USGS and application-based monitoring programs offer subscriptions to notifications. USGS provides an Earthquake Notification Service (ENS) that allows users to create specific boundaries on a map and establish earthquake magnitude thresholds within the boundary to receive automatic email notifications from the ENS. The email notifications will include the ShakeMap that shows the Intensity and Potential Damage. Similarly, the application-based programs allow users to receive notifications for earthquake magnitude thresholds and distances relative to where the device (i.e., smart phone, tablet) is located. The application QuakeFeed distributes the same ShakeMaps produced by USGS with the only difference being that the QuakeFeed is based on the location of the device (e.g., phone, tablet).

To have a consistent boundary and to have a clear understanding of who receives earthquake notifications, IRWD developed a boundary in ENS that has approximately a 75-mile radius from the intersection of the 5 and 405 freeways. The boundary, which is shown in the below Figure 3, is set to automatically distribute email notifications for seismic events within the boundary that are 3.5 magnitude or greater.

Earthquake Notification Service

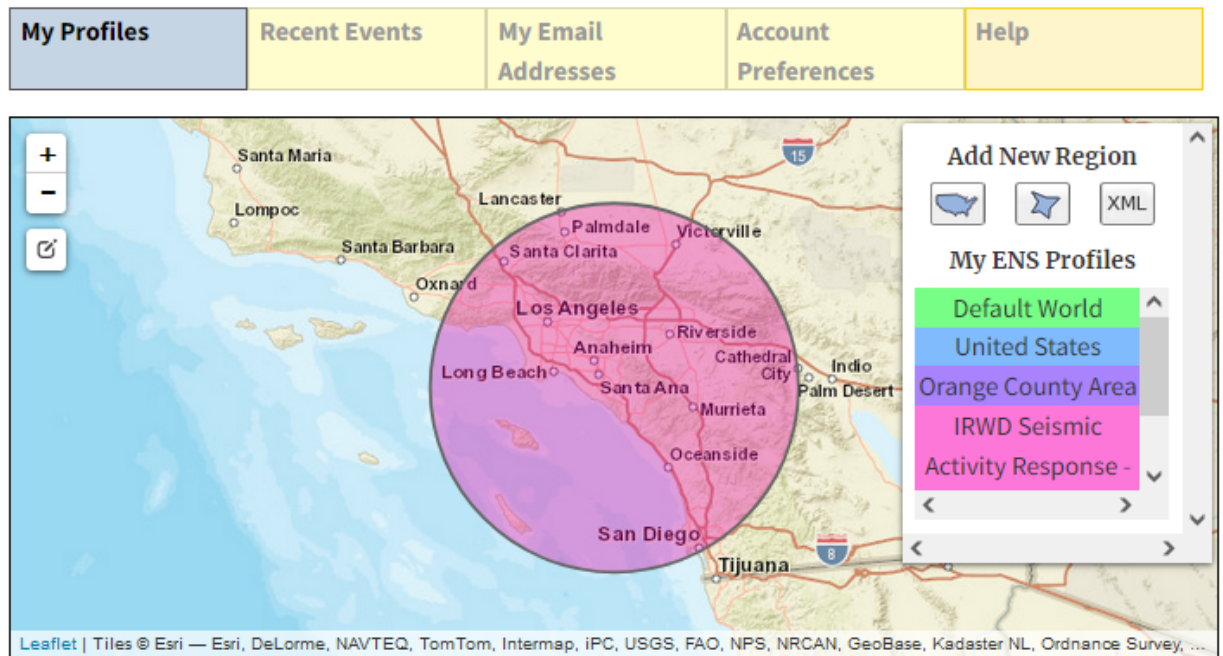

Figure 3: ENS 75-mile boundary for earthquake notifications.

The following IRWD employees are registered to receive notifications from ENS for qualifying earthquake events within the defined boundary.

- Bryan Clinton, Water Operations Manager
- Jose Zepeda, Director of Water & Recycling Operations
- (TBD), Construction Services Manager
- Gus Barreto, Field Services Manager
- Colt Martin, Operations & Maintenance Project Liaison
- Owen O'Neill, Electrical & Instrumentation Manager
- Harry Cho, Senior Engineer – Dams & Storage Group
- Jacob Moeder, Engineering Manager – Dams & Storage Group/Dam Safety Engineer
- Steve Choi, Director of Safety & Security

5.0 Responsibility

Various staff are responsible for monitoring and responding to seismic activity. Table 3 summarizes the responsibilities of staff for monitoring and responding to seismic activity.

Table 3: Seismic Monitoring Responsibilities		
Description of Responsibility	Responsible Party	Notes
Monitor seismic activity	Dam Safety Engineer, Water Operations staff, Director of Safety & Security	Staff monitoring seismic activity should use both USGS (based on user defined region) and application (based on location of device).
Collect and distribute piezometer data post a qualifying seismic event	Water Operations staff	
Review and assess piezometer data	Dam Safety Engineer, Water Operations staff	Dam Safety Engineer determines if collected data are acceptable or if it warrants input from dam safety experts
Survey benchmarks post a qualifying seismic event	Dam Safety Engineer	Dams & Storage group manages the land surveying contract for IRWD's dams
Review and assess survey data	Dam Safety Engineer	Dam Safety Engineer determines if collected data are acceptable or if it warrants input from dam safety experts
Communicate post seismic event inspection results to Executive Directors of Technical Services and Executive Director of Operations	Dam Safety Engineer or Water Operations Manager	
Communicate post seismic event inspection results to DSOD and coordinate DSOD's inspection	Dam Safety Engineer	
Manage USGS ENS for IRWD's seismic monitoring boundary	Dam Safety Engineer	

6.0 References

- 6.1 USGS Earthquake Monitoring Website: <https://earthquake.usgs.gov/>
- 6.2 QuakeFeed App: <https://www.quakefeed.com/>
- 6.3 http://usgs.github.io/shakemap/manual4_0/index.html

1.0 Purpose

The purpose of this document is to provide guidance for seepage and piezometer monitoring at Irvine Ranch Water District's (IRWD) dams.

2.0 Definitions

Below is a summary of terms used herein that are related to IRWD's Dam Safety Program (DSP).

Open-well Piezometer - a small diameter well used mainly to measure the pressure or depth of groundwater. The well is typically installed in a vertical borehole and has discrete perforated zones to monitor groundwater levels within a zone.

Piezometers - instruments used to measure the pore water pressure in the dam and define the phreatic surface.

Phreatic Surface - the top of the water table within the dam, which is also where the pressure head is zero.

Pneumatic Piezometer - instruments that are sealed in the borehole, embedded in fill or suspended in a standpipe. Twin pneumatic tubes run from the piezometer instrument to a terminal at the surface and readings are obtained with a pneumatic indicator.

Seepage Flow - the flow of water from the upstream side of the dam to the downstream side through or beneath the embankment.

Vibrating Wire Piezometer - an instrument with a high tensile steel wire attached to a diaphragm. The frequency of vibration in the wire induces an electrical current in a coil and the magnitude of the current is read and converted into pressure.

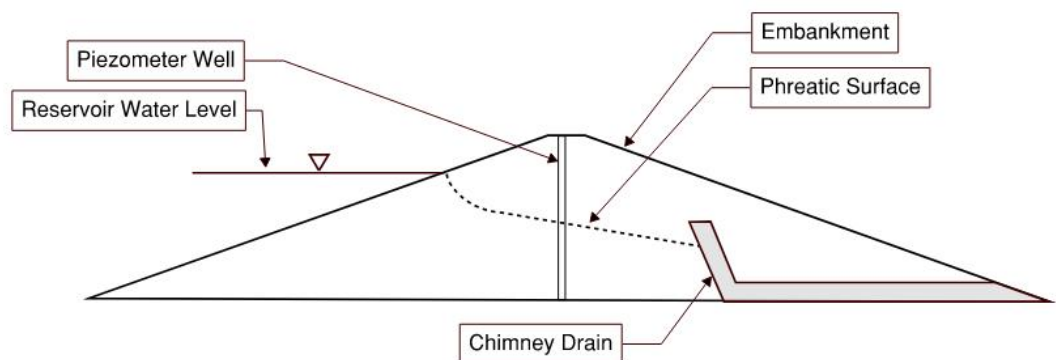

Figure 1: Embankment Features Related to Seepage

3.0 General Guidelines

All dams have some degree of seepage as water stored behind the dam seeks a path of least resistance through the dam and its foundation. Seepage becomes a concern when it is uncontrolled and carrying material with it. Seepage flows that carry materials can overtime lead to erosion of the dam or its foundation and lead to compromising the integrity of the dam. Seepage, and specifically the phreatic surface, can impact the stability of the embankment if the water level through the embankment is elevated and earth material strengths due to saturation.

IRWD’s seepage monitoring includes collecting, reviewing, and assessing information from three components of its earthen dams and then responding to the gathered information. Staff monitors the phreatic surface and seepage flow patterns with piezometers, seepage flow from subdrains, and sediment transportation in seepage vaults. In addition to monitoring the reservoir water level, the gathered information can collectively or individually inform staff on the performance of the dam. The response could include recording and filing the information, additional monitoring, field investigation, engineering analysis, or emergency response. Seepage monitoring includes piezometer monitoring, seepage flow monitoring, and sediment accumulation monitoring. The three areas and how IRWD monitors are summarized below.

3.1 Piezometer Monitoring

Piezometers are used to monitoring the phreatic surface through the earthen embankment. Table 1 below summarize the quantity, type, and location of piezometer instruments.

Table 1: Summary of Piezometers				
Dam	Open-Well	Vibrating Wire	Pneumatic	Total
San Joaquin	14	8	20	42
Sand Canyon	12	7	0	19
Syphon	4	8	0	12
Rattlesnake	20	1	0	21
Santiago Creek	22	0	0	22
Harding Canyon	0	0	0	0
<i>Total</i>	72	24	20	116

In 2022, IRWD contracted with Genterra Consultants, Inc. (Genterra) to develop piezometer, seepage flow, and movement thresholds and action levels for San Joaquin Dam, Sand Canyon Dam, and Rattlesnake Dam. Syphon Dam was excluded from the analysis since at the time of conducting the analysis the reservoir was drained and planned to remain drained until Syphon Dam was completely replaced. GEI Consultants, Inc. (GEI) developed the thresholds and action levels for Santiago Creek Dam, which are listed as Reference 6.4.

Dam Safety Program Guideline No. 4 Seepage & Piezometer Monitoring

Genterra’s approach to developing thresholds and action levels for piezometers includes reviewing historic performance, past reports, statistical analysis of piezometer readings with reservoir water levels. Genterra developed four alarm levels that offer predefined guidance for responses depending on each instrument reading. Though suggested responses are offered, other responses may include, and are not limited to, reviewing existing studies such as stability analysis, implementing a corrective action, or implementing interim risk reduction measures.

GEI utilized a different approach to establishing thresholds and action levels and instead of using statistical analysis they focused primarily on the stability analysis that GEI prepared in 2022, which assumed a certain phreatic surface based on a sensitivity analysis that provided a slope stability factor of safety required by DSOD. GEI’s end product included two levels (threshold and action) that are considered when reading piezometers and offer general guidance for responses.

To maintain consistency throughout this guideline, IRWD’s dam safety program utilizes the four-level alarm system for piezometer and seepage monitoring. The alarm levels are integrated into piezometer readings for San Joaquin Dam, Sand Canyon Dam, and Rattlesnake, and will be integrated into the other dams in the future at the appropriate time. The alarm levels and responses are described in Table 2 below.

Table 2: Alarm Levels and Response Plan for Piezometers and Seepage Flows for San Joaquin Dam, Sand Canyon Dam, and Rattlesnake Dam		
Status	Description	Response
Level I Green Alarm Normal	Observations and measurements from monitoring indicate expected and acceptable values.	<ul style="list-style-type: none"> No immediate action required. Continue routine inspection, monitoring, and maintenance program.
Level II Yellow Alarm Out of Range	<ul style="list-style-type: none"> For piezometers, readings are outside of expected range set by upper band and lower band, but within and up to 1 foot of established bands. For seepage flow, values that exceed historic maximums or above the upper band value if it is established with adequate historical data. 	<ul style="list-style-type: none"> Review the data for reliability. Staff should take an additional two readings to confirm that the reading was initially taken is not an erroneous reading. If additional readings confirm that the original reading is correct, then perform close visual inspection of the area that correlates with the reading. Inform Dam Safety Engineer. Determine if additional monitoring is required.

Dam Safety Program Guideline No. 4 Seepage & Piezometer Monitoring

Table 2: Alarm Levels and Response Plan for Piezometers and Seepage Flows for San Joaquin Dam, Sand Canyon Dam, and Rattlesnake Dam		
Status	Description	Response
Level III Orange Alarm Increased Surveillance Alarm	<ul style="list-style-type: none"> For piezometers, readings are outside of expected range set by upper band and lower band, but within and up to 1 foot to 3 feet from established bands. For seepage flow, values that exceed historic maximums or above the upper band value if it is established with adequate historical data, and seepage flow carries sediments and appears cloudy. 	<ul style="list-style-type: none"> Staff should take additional readings to confirm that the reading was initially taken is not an erroneous reading. If the additional readings confirm that the original reading is correct, then staff should start to perform an increased frequency of close visual inspections of the area and take more frequent readings to determine rate of increase or decrease, if any, for evaluation by the Dam Safety Engineer. If work is occurring in affected area, direct all work to cease. Inform parties involved with dam safety program if alarm level is consistent. If needed, engage the involvement of Dam Engineering Consultant to confirm the severity. Determine if a dam safety risk exists.
Level IV Red Alarm Immediate Action	<ul style="list-style-type: none"> For piezometers, readings are outside of expected range set by upper band and lower band and more than 3 feet of established bands. The range for Red Alert or confirmation of Red Alert, should be updated after additional work to determine updated factors of safety for slope stability. For seepage flow, values of flow that exceed historic maximums or above the upper band value if it is established with adequate historical data, and seepage flow carry sediments and appears cloudy and seepage flow and sediment discharge continued to increase with time. 	<ul style="list-style-type: none"> Staff should take additional readings to confirm that the reading was initially taken is not an erroneous reading. If the additional readings confirm that the original reading is correct, then staff should start to perform daily close visual inspections of the area and take more frequent readings to determine rate of increase or decrease, if any, for evaluation by the Dam Safety Engineer. If work is occurring in affected area, direct all work to cease. Inform parties involved with dam safety program. Engage the involvement of Dam Engineering Consultant to confirm the severity. Determine if a dam safety risk exists. Consider activating the Emergency Action Plan (EAP) if imminent failure or high flow condition is predicted by the Dam Safety Engineer or Dam Engineering Consultant. Be ready to draw down the reservoir to reduce risk as directed by IRWD or DSOD.

3.1.1 San Joaquin Dam, Sand Canyon Dam, and Rattlesnake Dam Piezometer Thresholds and Action Levels

The piezometer thresholds and action levels are based on reservoir water levels, historical readings, and statistical analysis. The specific methodology is described in the

three separate technical memoranda that Genterra prepared in 2023 for San Joaquin Dam, Sand Canyon Dam, and Rattlesnake Dam. The reports are included as Reference 6.1, 6.2, and 6.3. The dynamic alarm levels are integrated into an excel file that Water Operations manages to historize piezometer readings. Once Water Operations staff collect the piezometer data, the readings are entered into the alarm levels spreadsheet to determine if the readings are within the expected range and if immediate re-readings are warranted based on the identified alarm level. Alarms from Level I to Level IV are generated based on the existing reservoir water level, piezometer reading, and historic readings with corresponding guidance for potential responses.

3.1.2 Santiago Creek Dam Piezometer Thresholds and Action Levels

To be updated upon completion of Santiago Creek Dam Improvements construction.

3.1.3 Syphon Dam Piezometer Thresholds and Action Levels

To be updated near the completion of Syphon Dam Improvements construction.

3.2 Seepage Monitoring

Staff monitors seepage flow at San Joaquin Dam, Sand Canyon Dam, and Rattlesnake Dam. Consistent seepage monitoring is an important part of IRWD's DSP as it provides early information on internal erosion, performance of filter drains, and changes in the overall dam performance. Seepage flowrates in conjunction with piezometer data helps develop an understanding of flow path through the embankment and can help identify areas to focus when troubleshooting a concern. Table 3 below summarizes the quantity of seepage monitoring locations at each dam and the quantity of subdrain systems monitored. The Annual Surveillance Report for each dam describes the seepage monitoring locations and historic range of flows. Seepage flow rates are recorded and distributed monthly by Water Operations and reviewed by Water Operations, Dam Safety Engineer, and the Dam Engineering Consultant.

**Dam Safety Program
Guideline No. 4
Seepage & Piezometer Monitoring**

Table 3: Summary of Seepage Monitoring Locations			
Dam	Quantity of Monitoring Locations	Quantity of Monitored Subdrains	Notes
San Joaquin	3	8	Locations identified as 1) East Drain, 2) West Drain, 3) Filter Drain (locations 1-3 in vault structure near right toe of dam), 4) Upstream Collector Drain No. 1, 5) Upstream Collector Drain No. 2 (locations 4-5 in weir box at lowest bench), 6) Downstream Toe Drain, 7) Right Groin Drain, and 8) Floor Drain (locations 6-8 at seepage recovery structure near energy dissipator).
Sand Canyon	1	2	A Left Subdrain was installed soon after construction when seepage was discovered after initial filling. In 1976, the Right Subdrain was added.
Syphon	1	1	It is unknown where the seepage originates, but it flows when water is in the reservoir.
Rattlesnake	2	8	<ul style="list-style-type: none"> • FP-2, FP-3, and FP-4 collect seepage from chimney drain within the dam. • FP-2, FP-3, FP-4, FP-5, FP-8, and FP-11 are monitored in the Seepage Vault. • FP-1 North and FP-1 South are read in Manhole No. 1 about 600-ft downstream of Seepage Vault.
Santiago Creek	0	0	
Harding Canyon	0	0	
<i>Total</i>	<i>7</i>	<i>19</i>	

Similar to the piezometer monitoring, the seepage flow rate corresponds with reservoir level and is described in the technical memoranda included as references 6.1, 6.2, and 6.3 for San Joaquin Dam, Sand Canyon Dam, and Rattlesnake Dam respectively. The alarm levels were developed based on historic seepage flow rates at various monitoring locations. These alarms are integrated into an excel file that Water Operations manages to historize seepage flow rate readings.

3.3 Sediment Monitoring

Sediment monitoring is also an important part of IRWD’s DSP because it can provide information as to the amount of internal erosion and possibly where in the embankment the erosion is occurring. IRWD monitors sediment accumulation at all flow monitoring points when sediment accumulation is observed. Once the wet sediment samples are collected, they are dried, and the dried weight is recorded. Laboratory tests are also occasionally performed and assessed by a qualified engineer to identify the type of sediment being collected. Significant increase in

**Dam Safety Program
Guideline No. 4
Seepage & Piezometer Monitoring**

sediment accumulations are flagged and discussed with Water Operations, Dam Safety Engineer, and as needed Dam Engineering Consultant.

4.0 Responsibility

Various staff are responsible for seepage and piezometer monitoring activity. Table 4 summarizes the responsibilities of staff for the monitoring activity.

Table 4: Seepage & Piezometer Activity Management Responsibilities		
Description of Responsibility	Responsible Party	Notes
Collect, record, and distribute piezometer data	Water Operations Staff	Occurs monthly
Review piezometer data	Water Operations Staff, Dam Safety Engineer, Dam Engineering Consultant	Occurs monthly
Collect, record, and distribute seepage flow rates	Water Operations Staff	Occurs monthly
Review seepage flow rates	Water Operations Staff, Dam Safety Engineer, Dam Engineering Consultant	Occurs monthly
Collect, process, record and distribute sediment accumulation data	Water Operations Staff	Occurs monthly (less frequent if sediment accumulation is not observed)
Review sediment accumulation data	Water Operations Staff, Dam Safety Engineer, Dam Engineering Consultant	Occurs monthly

5.0 Exhibits

- 5.1 GEI, “Site and Instrumentation Plan for San Joaquin Dam”, September 2022.
- 5.2 GEI, “Site and Instrumentation Plan for Sand Canyon Dam”, September 2022.
- 5.3 GEI, “Site and Instrumentation Plan for Syphon Dam”, September 2022.
- 5.4 GEI, “Site and Instrumentation Plan for Rattlesnake Dam”, September 2022.
- 5.5 GEI, “Site and Instrumentation Plan for Santiago Creek Dam”, September 2022.

6.0 References



- 6.1 Genterra, “Technical Memorandum Identification of Instrumentation Thresholds and Action Levels at San Joaquin Dam”, January 13, 2023.
- 6.2 Genterra, “Technical Memorandum Identification of Instrumentation Thresholds and Action Levels at Sand Canyon Dam”, March 24, 2023.

**Dam Safety Program
Guideline No. 4
Seepage & Piezometer Monitoring**

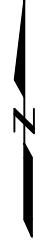
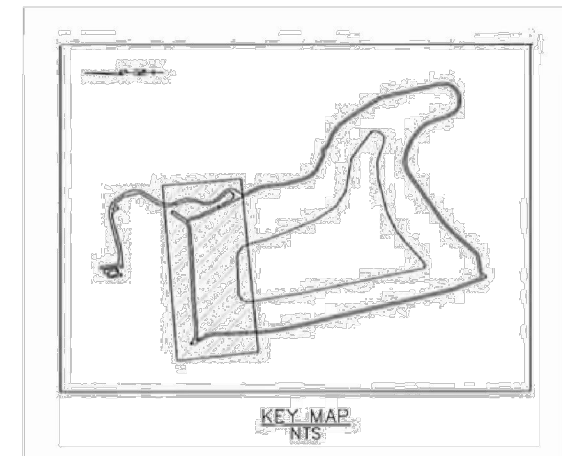
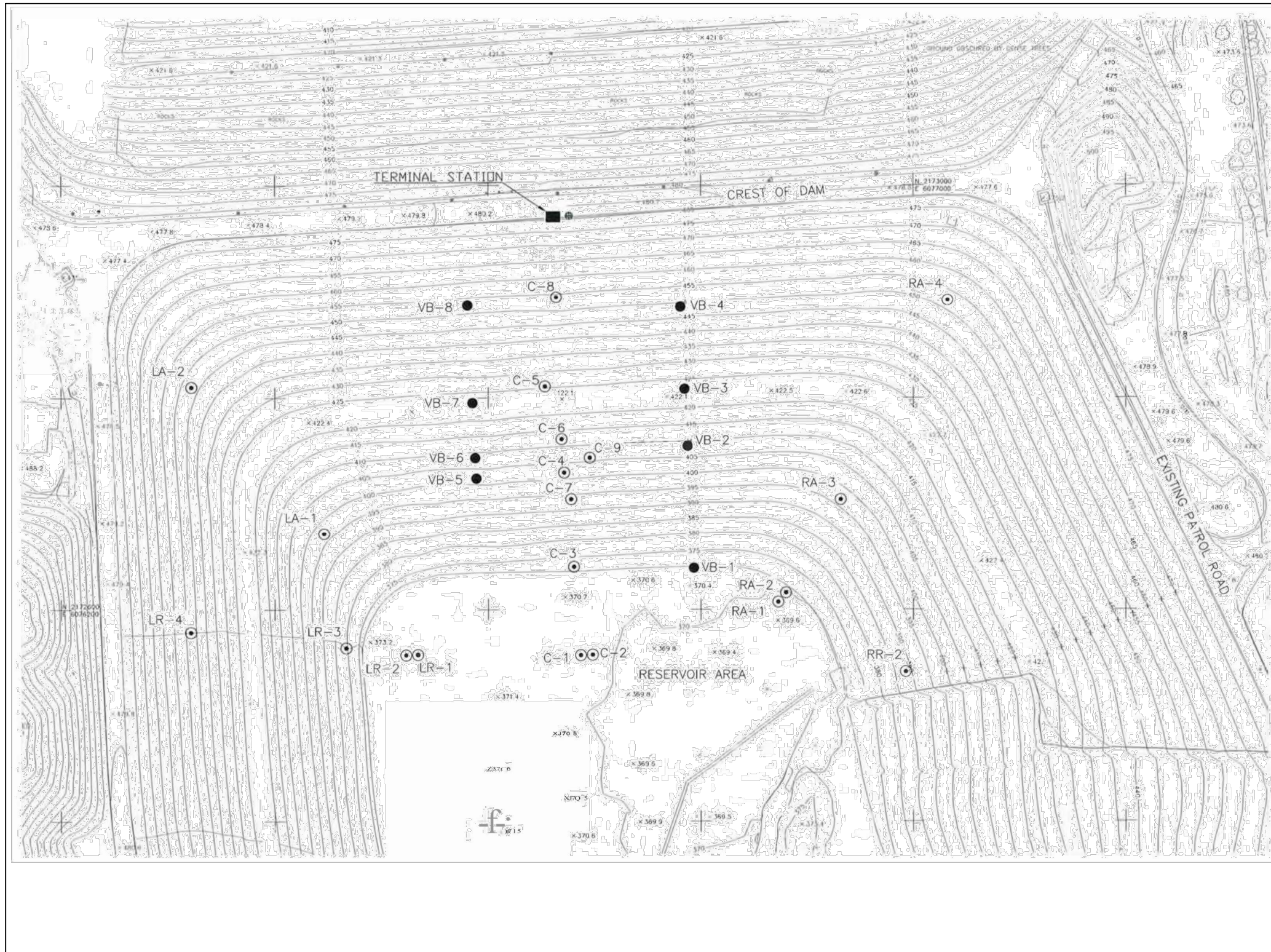
- 6.3 Genterra, “Technical Memorandum Identification of Instrumentation Thresholds and Action Levels at Rattlesnake Dam”, March 22, 2023.
- 6.4 GEI, “Instrumentation Evaluation and Upgrade Recommendation”, October 31, 2022.

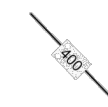

LEGEND

-  3' CONTOUR LINES
-  VIBRATING WIRE PIEZOMETER
-  PNEUMATIC PIEZOMETER

NOT TO SCALE

Annual Surveillance Report from Jan. 2021 to Dec. 2021
 San Joaquin Dam and Reservoir
 Irvine, CA
 Irvine Ranch Water District
 Irvine, CA



DAM EMBANKMENT AND
 ABUTMENT LOCATIONS

Project 1901888



September 2022

Fig. 3

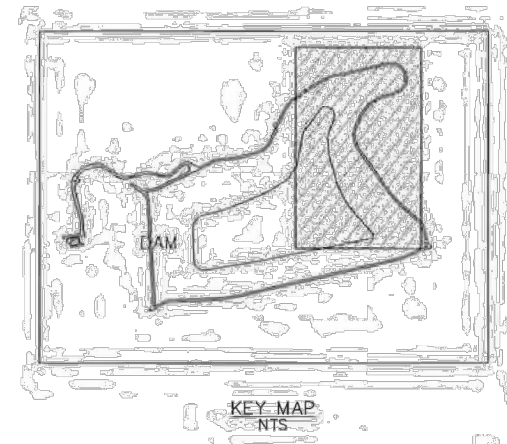
Exhibit 5.1 - Site and Instrumentation Plan for San Joaquin Dam



LEGEND

-  OPEN-WELL PIEZOMETER
-  MONITORING WELLS

NOT TO SCALE

Annual Surveillance Report from Jan. 2021 to Dec. 2021 San Joaquin Dam and Reservoir Irvine, CA		LOCATIONS OF OPEN-WELL PIEZOMETERS AND MW-4 AND MW-5
Irvine Ranch Water District Irvine, CA	Project 1901888	September 2022 Fig. 4

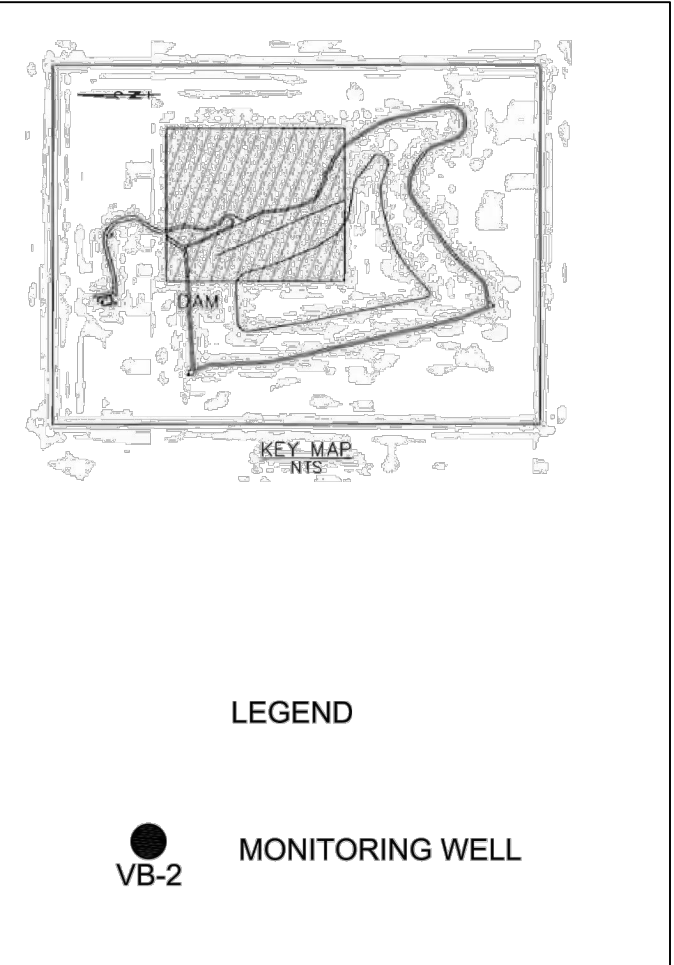
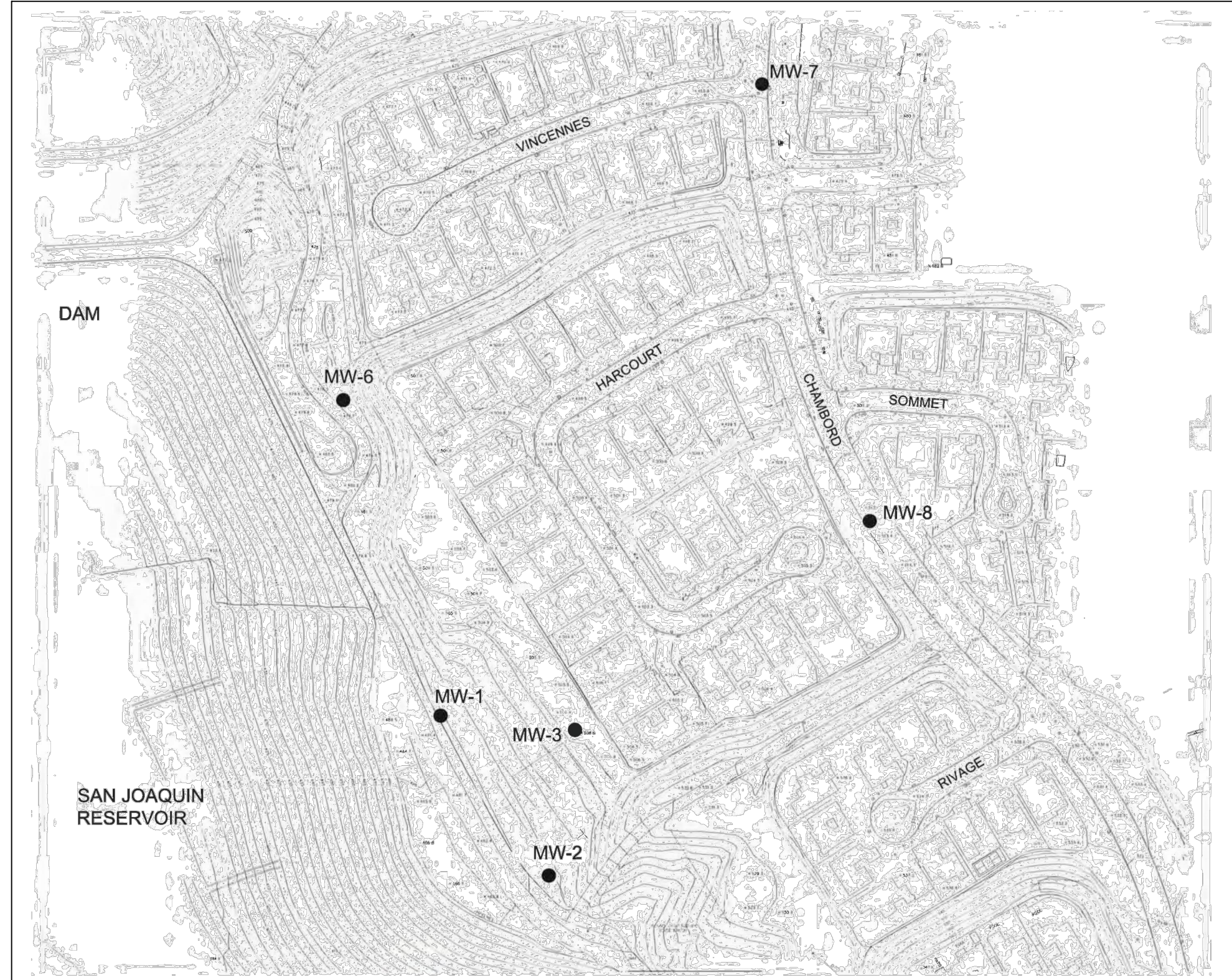

SAN JOAQUIN RESERVOIR

DAM

MW-6

MW-7

MW-3

MW-8

MW-1

MW-2

VINCENNES

HARCOURT

CHAMBORD

SOMMET

RIVAGE

KEY MAP
NTS

LEGEND

● VB-2 MONITORING WELL

NOT TO SCALE

Annual Surveillance Report from Jan. 2021 to Dec. 2021
 San Joaquin Dam and Reservoir
 Irvine, CA
 Irvine Ranch Water District
 Irvine, CA

GEI Consultants
 Project 1901888

LOCATIONS OF MW-1, MW-2,
 MW-3, MW-6, MW-7, AND MW-8

September 2022

Fig. 5

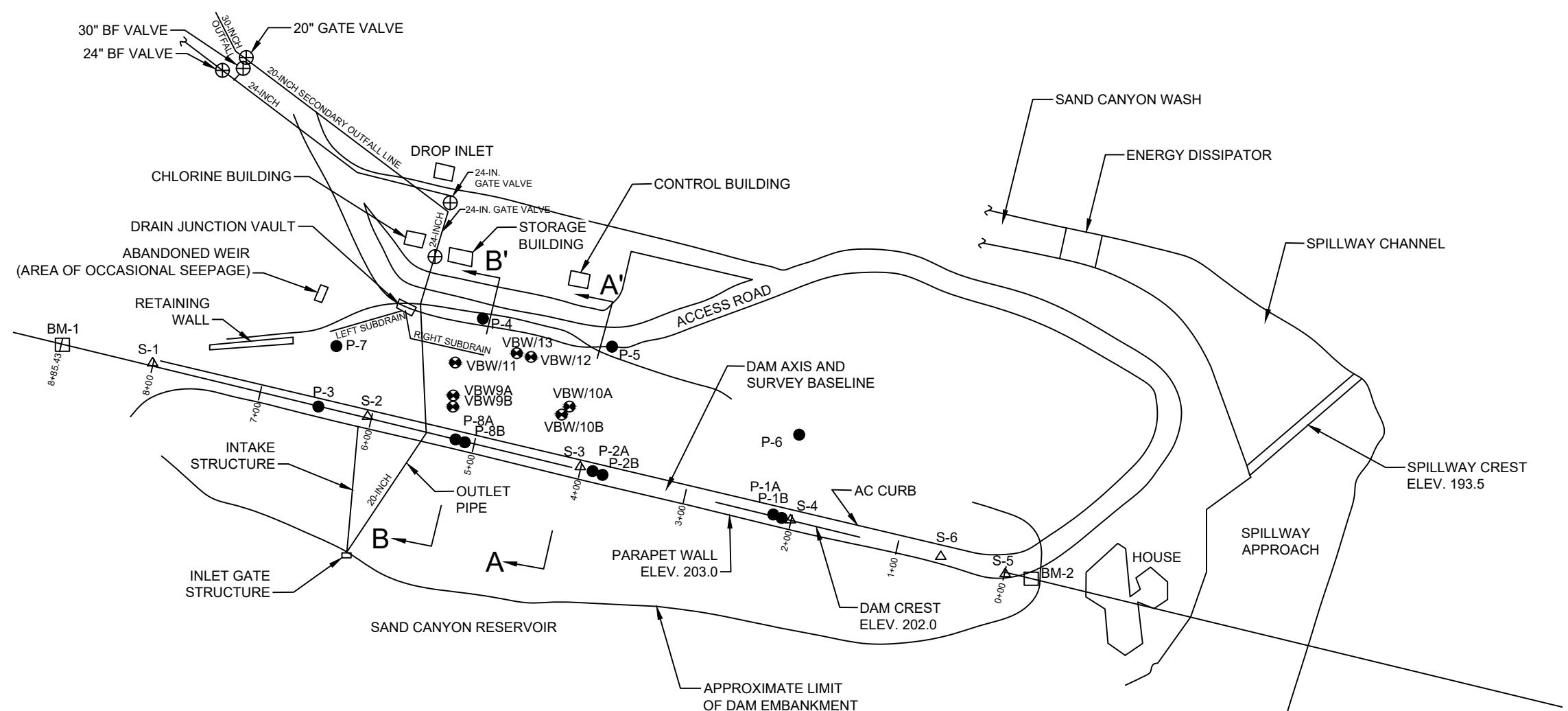

LEGEND

- ⊕ VBW/13 VIBRATING WIRE PIEZOMETER
- P-2A OPEN WELL PIEZOMETER
- △ S-3 SURVEY MONUMENT
- BM-1 BENCH MARK
- A — A' LINE OF SECTION
- — — — — OUTLET PIPE
- — — — — SEEPAGE SUBDRAIN
- 0+00 — STATION NUMBER

- NOTES:**
- (1) SECTION A-A' IS SHOWN ON FIGURE 2
 - (2) SECTION B-B' IS SHOWN ON FIGURE 3
 - (3) ELEVATIONS ARE IN FEET RELATIVE TO NGVD29 DATUM
 - (4) LOCATIONS OF OUTLET PIPES AND VALVES ARE ESTIMATED

NOT TO SCALE

Annual Surveillance Report from Jan. 2021 to Dec. 2021 Sand Canyon Dam Irvine, CA		SITE AND INSTRUMENTATION PLAN	
Irvine Ranch Water District Irvine, CA		Project 1901888	September 2022

Fig. 1

Exhibit 5.2 - Site and Instrumentation Plan for Sand Canyon Dam

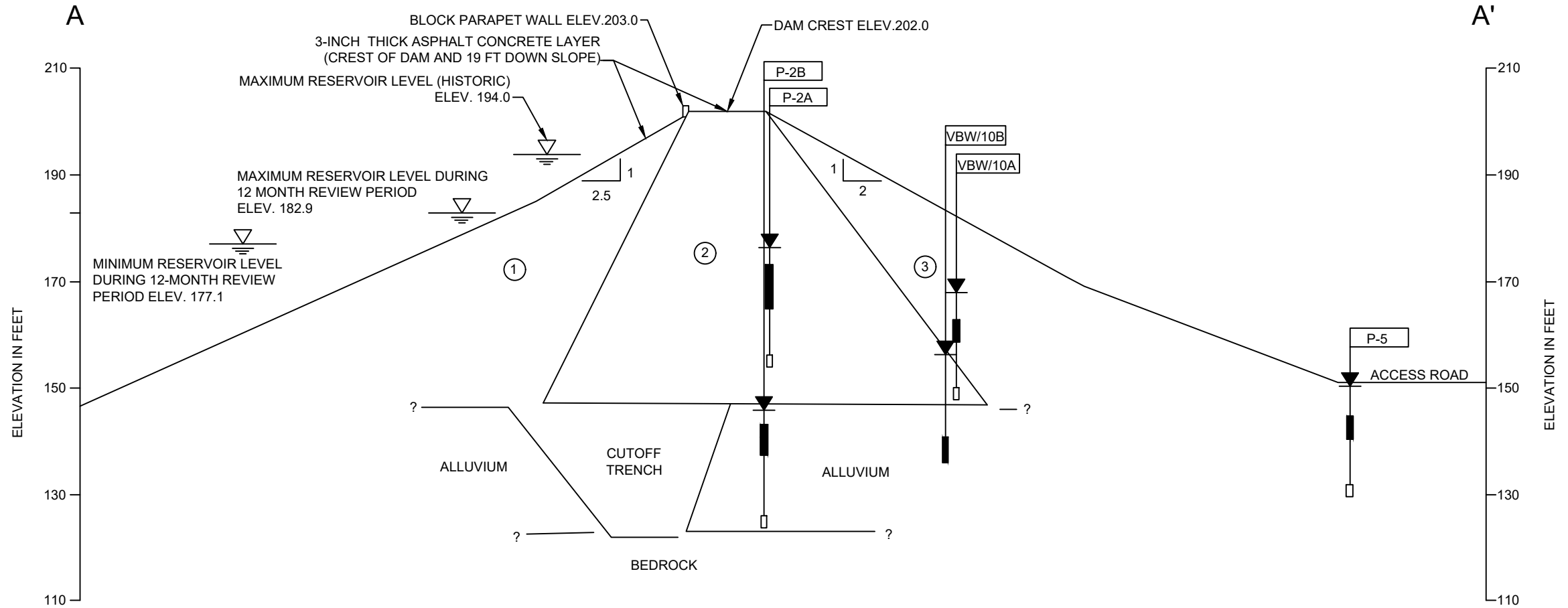

LEGEND

MATERIALS

- ① SELECTED IMPERVIOUS
- ② RANDOM
- ③ UNSELECTED PERVIOUS

- P-2B PIEZOMETER (OPEN WELL TYPE)
- SURFACE OF DAM
- MAXIMUM HISTORICAL LEVEL
- HIGH RANGE OF MEASURED LEVELS IN PIEZOMETER DURING 12 MONTH REVIEW PERIOD
- LOW
- PIEZOMETER TIP

NOTE: QUESTIONABLE READINGS ARE NOT SHOWN

NOTES:

(1) SEE FIGURE 1 FOR LOCATION OF SECTION

(2) ELEVATIONS ARE IN FEET RELATIVE TO NGVD29

NOT TO SCALE

Annual Surveillance Report from Jan. 2021 to Dec. 2021 Sand Canyon Dam Irvine, CA		SECTION A-A'
Irvine Ranch Water District Irvine, CA	Project 1901888	September 2022 Fig. 2

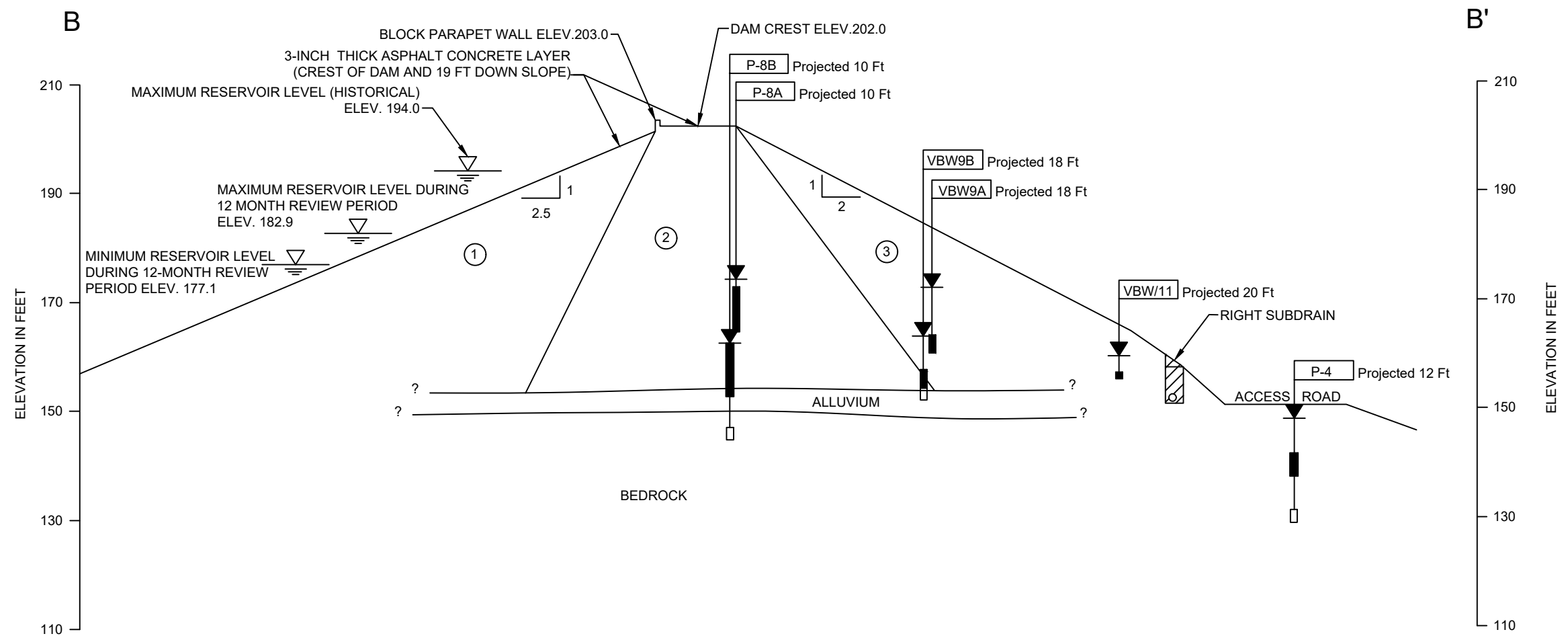

- MATERIALS**
- ① SELECTED IMPERVIOUS
 - ② RANDOM
 - ③ UNSELECTED PERVIOUS

LEGEND

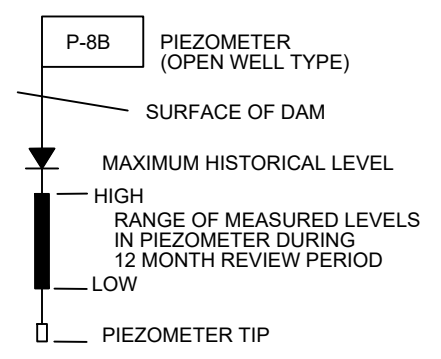

NOTE: QUESTIONABLE READINGS ARE NOT SHOWN

- NOTES:**
- (1) SEE FIGURE 1 FOR LOCATION OF SECTION
 - (2) ELEVATIONS ARE IN FEET RELATIVE TO NGVD29

NOT TO SCALE

Annual Surveillance Report from Jan. 2021 to Dec. 2021 Sand Canyon Dam Irvine, CA		SECTION B-B'	
Irvine Ranch Water District Irvine, CA		Project 1901888	September 2022

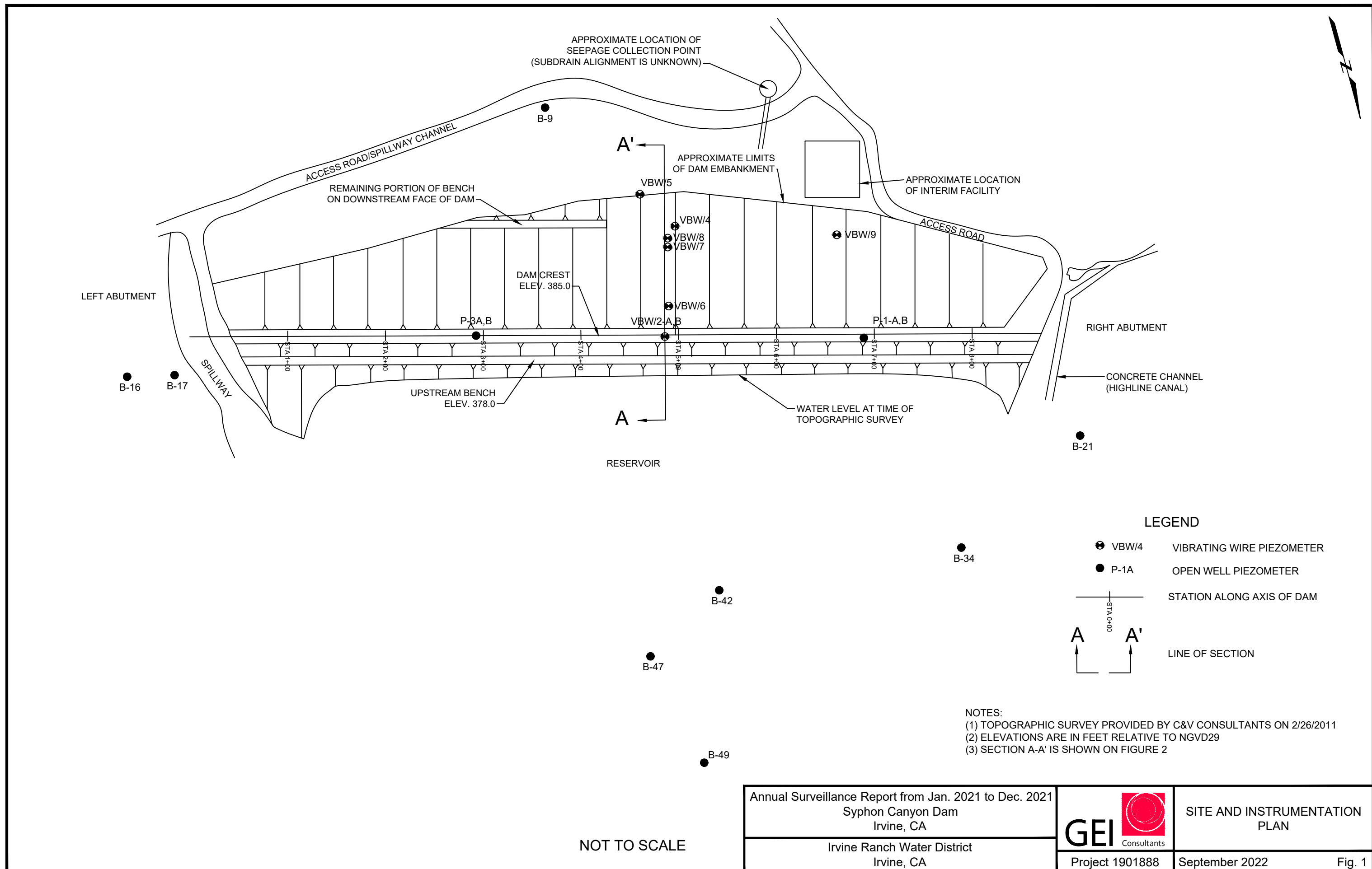

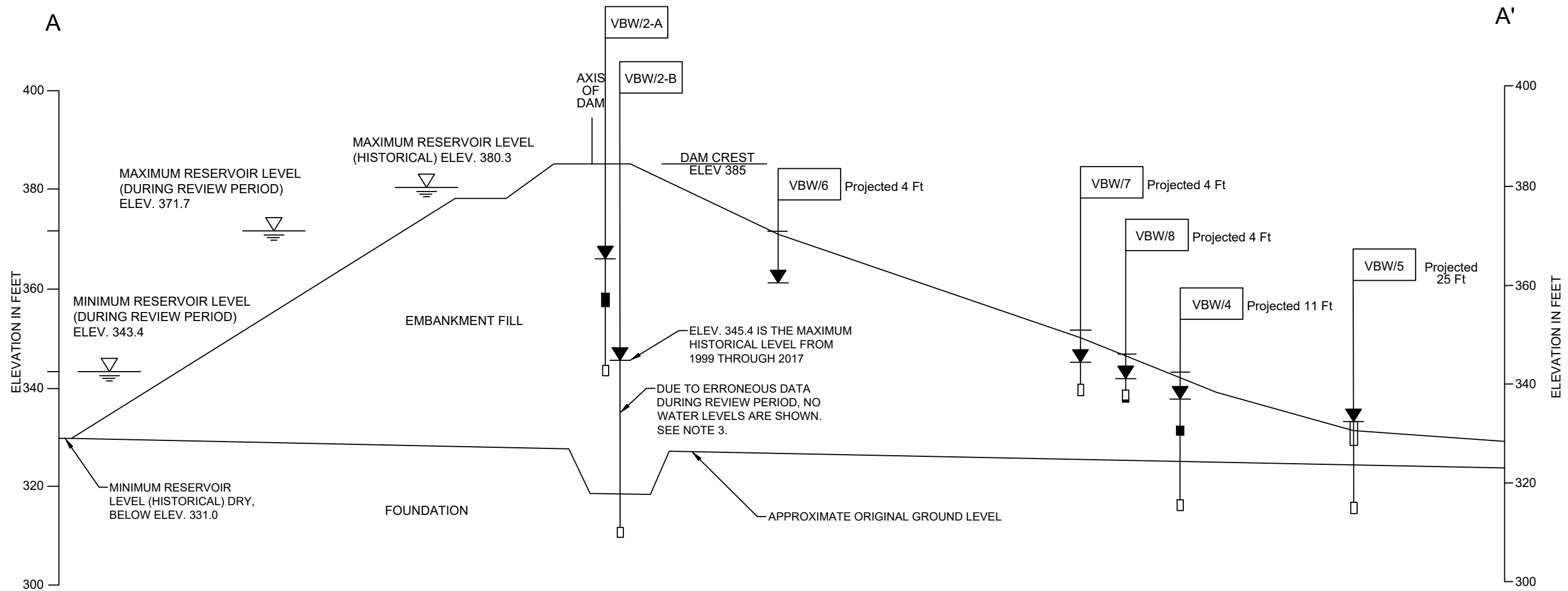

Exhibit 5.3 - Site and Instrumentation Plan for Syphon Dam

Annual Surveillance Report from Jan. 2021 to Dec. 2021 Syphon Canyon Dam Irvine, CA		SITE AND INSTRUMENTATION PLAN
Irvine Ranch Water District Irvine, CA	Project 1901888	September 2022 Fig. 1

NOT TO SCALE

- NOTES:
- (1) TOPOGRAPHIC SURVEY PROVIDED BY C&V CONSULTANTS ON 2/26/2011
 - (2) ELEVATIONS ARE IN FEET RELATIVE TO NGVD29
 - (3) SECTION A-A' IS SHOWN ON FIGURE 2



LEGEND

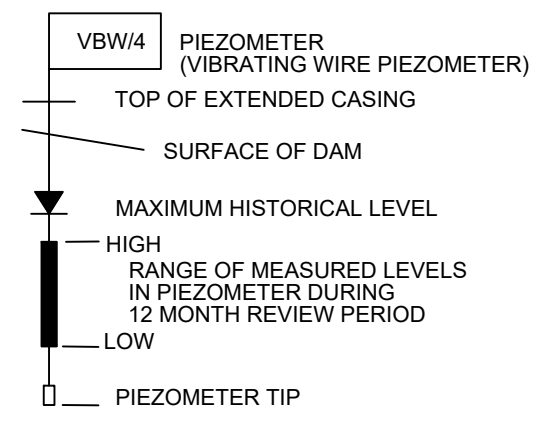

**SECTION A-A'
(MAXIMUM SECTION)**

- NOTES:**
 (1) LOCATION OF SECTION A-A' IS SHOWN ON FIGURE 1
 (2) ELEVATIONS ARE IN FEET RELATIVE TO NGVD29
 (3) ERRONEOUS READINGS WERE CAUSED BY INCORRECT DATA LOGGER CONVERSION SETTINGS.

NOT TO SCALE

Annual Surveillance Report from Jan. 2021 to Dec. 2021 Syphon Canyon Dam Irvine, CA		SECTION A-A'
Irvine Ranch Water District Irvine, CA	Project 1901888	September 2022 Fig. 1A

LEGEND

- P-67 PIEZOMETER OR OBSERVATION WELL
- △ D SUBSURFACE SURVEY MONUMENT
- ⑧ FLOW POINT ID
- SEEPAGE VAULT
- BM-3 BENCH MARK
- ══ OUTLET PIPE
- ══ SUBDRAIN LINE
- +— STATION ALONG AXIS OF DAM
- A A' LINE OF SECTION

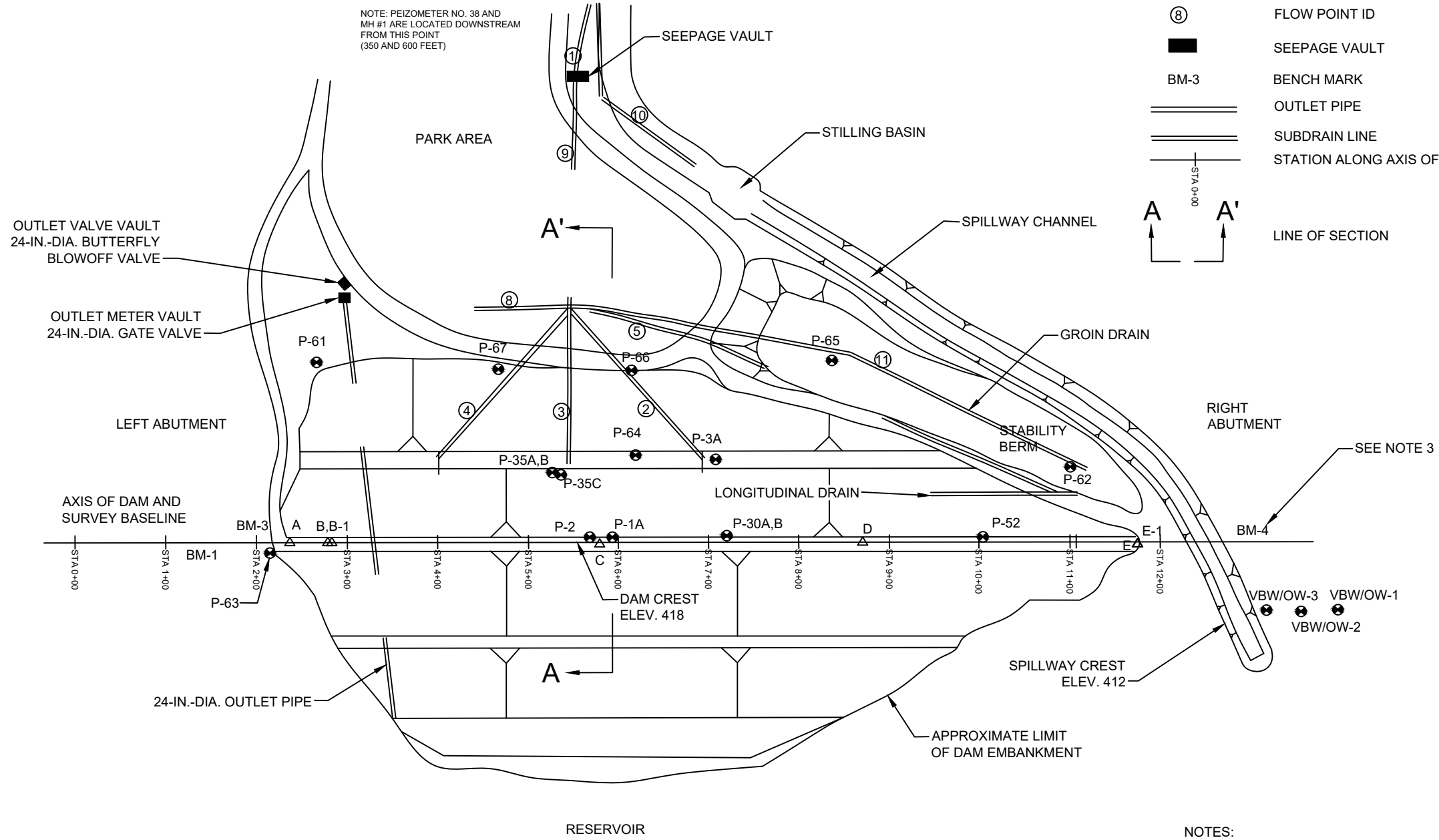
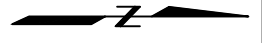

- NOTES:
1. SECTION A-A' SHOWN ON FIGURE 2
 2. ELEVATIONS ARE IN FEET RELATIVE TO NGVD29
 3. BM-4 WAS DESTROYED BETWEEN 2015 AND 2016. BM-4 WAS RE-ESTABLISHED BY 2018

NOT TO SCALE

Annual Surveillance Report from Jan. 2021 to Dec. 2021
 Rattlesnake Canyon Dam and Reservoir
 Irvine, CA
 Irvine Ranch Water District
 Irvine, CA



SITE AND INSTRUMENTATION PLAN
 Project 1901888
 September 2022
 Fig. 1

Exhibit 5.4 - Site and Instrumentation Plan for Rattlesnake Dam

L

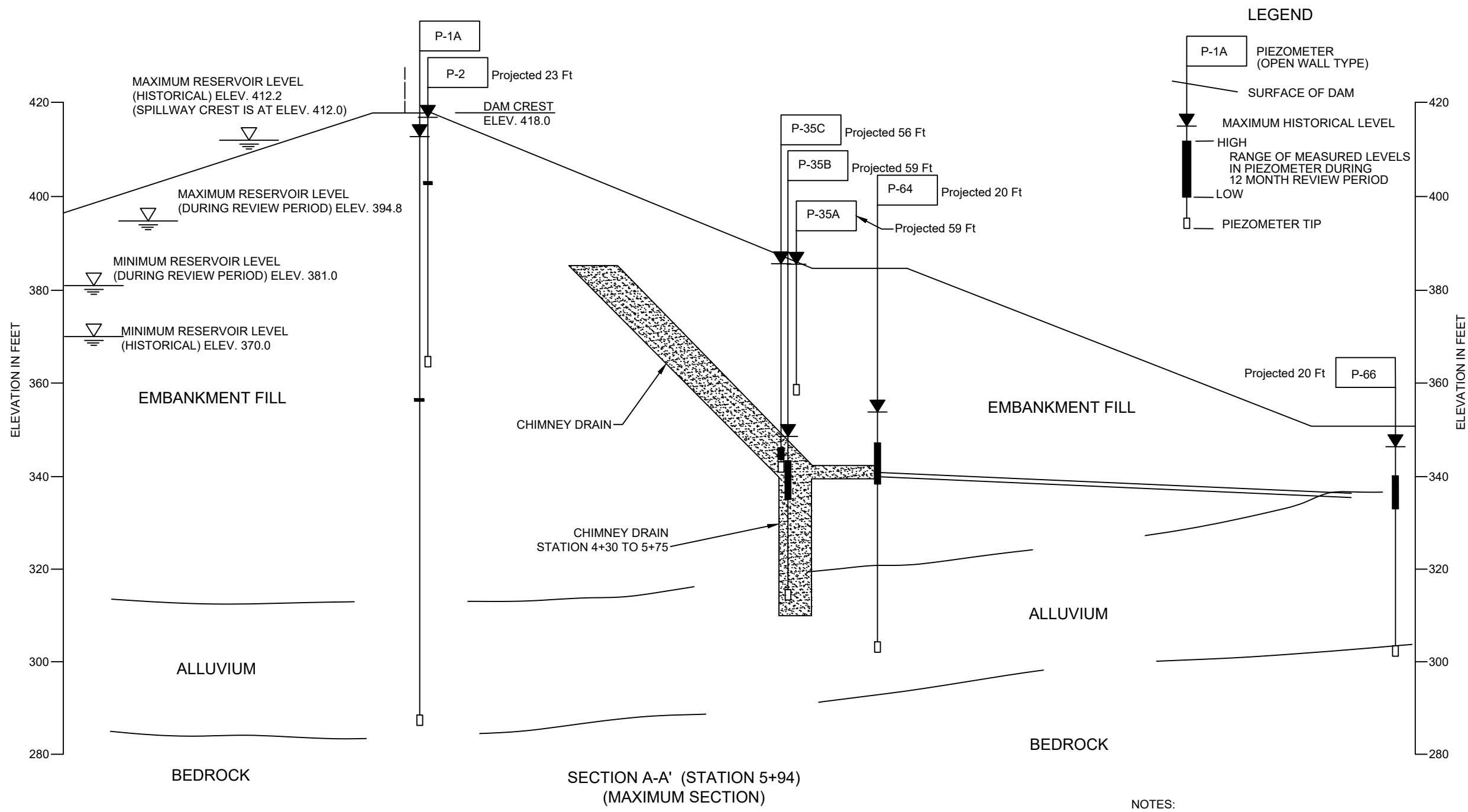

9

NOT TO SCALE

Annual Surveillance Report from Jan. 2021 to Dec. 2021 Rattlesnake Canyon Dam and Reservoir Irvine, CA		SECTION A-A'
Irvine Ranch Water District Irvine, CA	Project 1901888	September 2022 Fig. 2

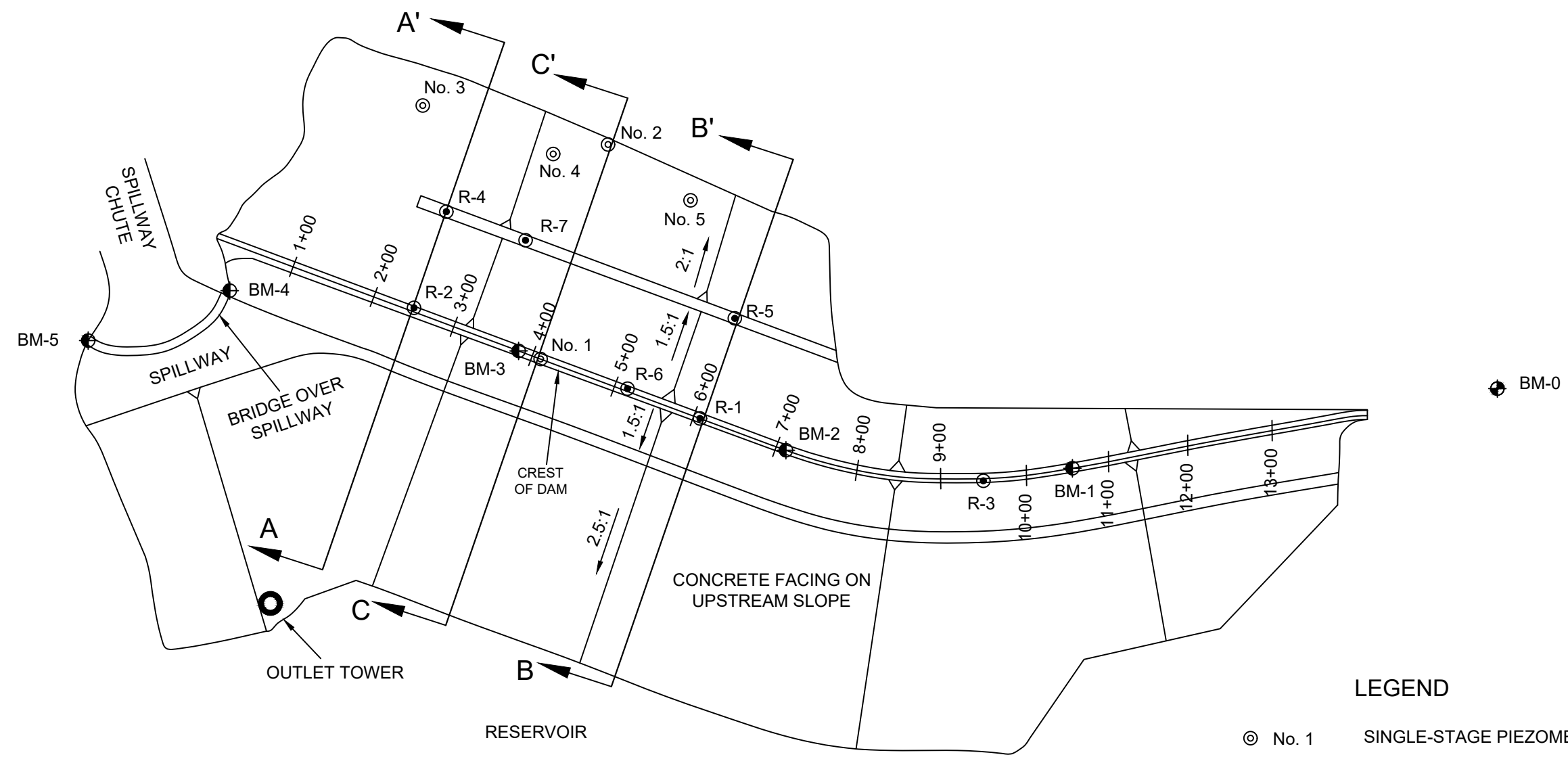

LEGEND

- ⊙ No. 1 SINGLE-STAGE PIEZOMETER
- ⊙ R-2 MULTI-STAGE PIEZOMETER
- ⊕ BM-5 SURVEY MONUMENTS
- ⊕ BM-0 BENCHMARK

NOTE: SECTIONS A-A', B-B' AND C-C' ARE SHOWN ON FIGURES 1B, 1C, AND 1D RESPECTIVELY.

NOT TO SCALE

Annual Surveillance Report from Jan. 2021 to Dec. 2021 Santiago Creek Dam Irvine, CA		SITE AND INSTRUMENTATION PLAN
Irvine Ranch Water District Irvine, CA	Project 1901888	September 2022 Fig. 1A

Exhibit 5.5 - Site and Instrumentation Plan for Santiago Creek Dam



LEGEND

- R-1 PIEZOMETER (OPEN WELL TYPE)
- SURFACE OF DAM
- MAXIMUM HISTORICAL LEVEL (SINCE JANUARY 1998)
- HIGH RANGE OF MEASURED LEVELS IN PIEZOMETER DURING 12 MONTH REVIEW PERIOD
- LOW
- PIEZOMETER TIP
- RESERVOIR WATER SURFACE

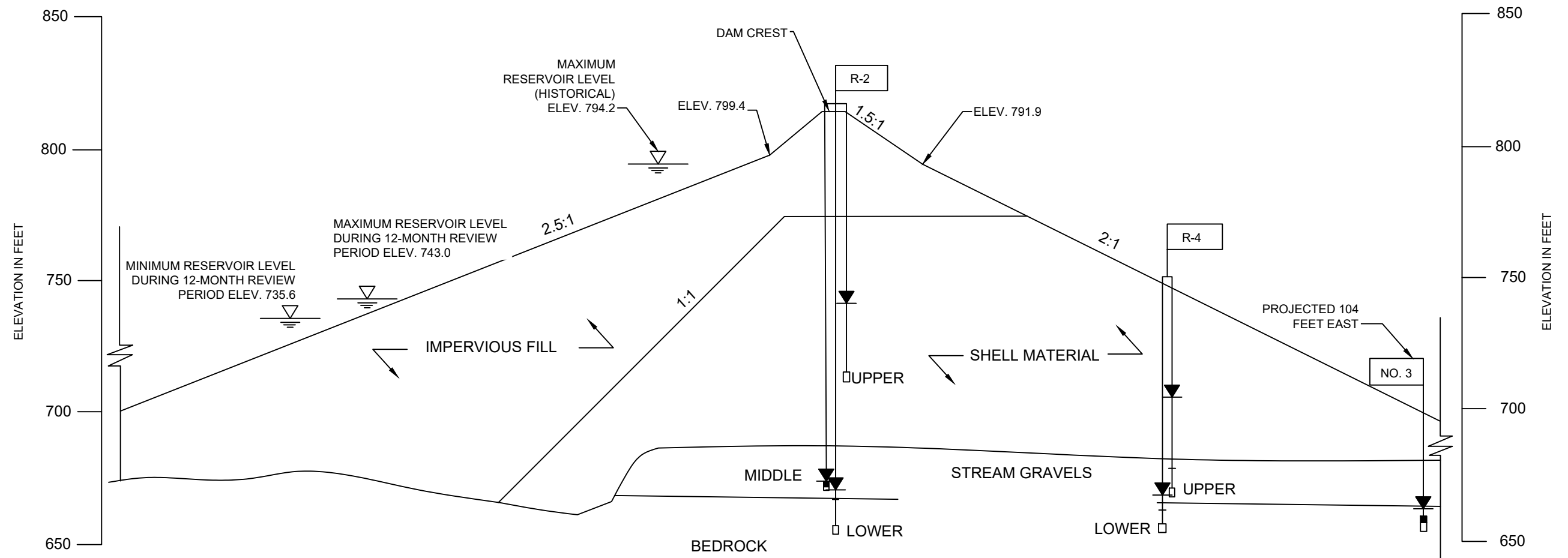
- NOTES:
- (1) SEE FIGURE 1 FOR LOCATION OF SECTION
 - (2) QUESTIONABLE READINGS ARE NOT SHOWN

**SECTION A-A'
MAXIMUM SECTION
(APPROX. STA 2+50)**

NOT TO SCALE

Annual Surveillance Report from Jan. 2021 to Dec. 2021 Santiago Creek Dam Irvine, CA		SECTION A-A'
Irvine Ranch Water District Irvine, CA	Project 1901888	September 2022 Fig. 1B

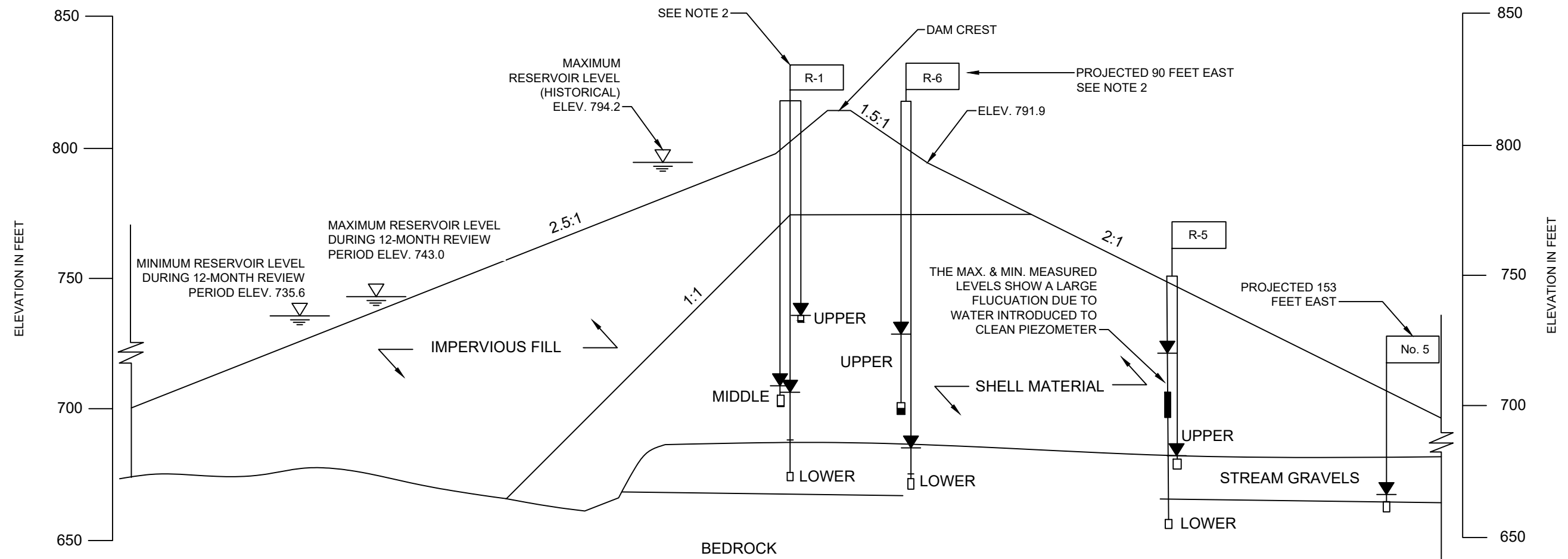

LEGEND

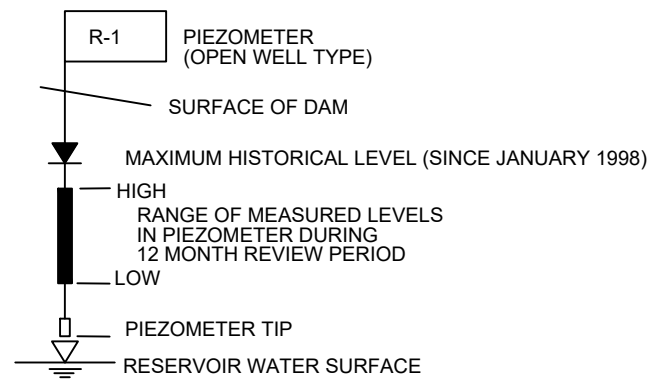

NOTES:

- (1) SEE FIGURE 1A FOR LOCATION OF SECTION
- (2) PIEZOMETERS R-1 AND R-6 ALIGN HORIZONTALLY WITH THE CENTER OF THE DAM CREST AND HAVE BEEN DISPLACED FOR PRESENTATION PURPOSES
- (3) QUESTIONABLE READINGS ARE NOT SHOWN

**SECTION B-B'
(APPROX. STA 6+00)**

NOT TO SCALE

Annual Surveillance Report from Jan. 2021 to Dec. 2021 Santiago Creek Dam Irvine, CA		SECTION B-B'	
Irvine Ranch Water District Irvine, CA		Project 1901888	September 2022

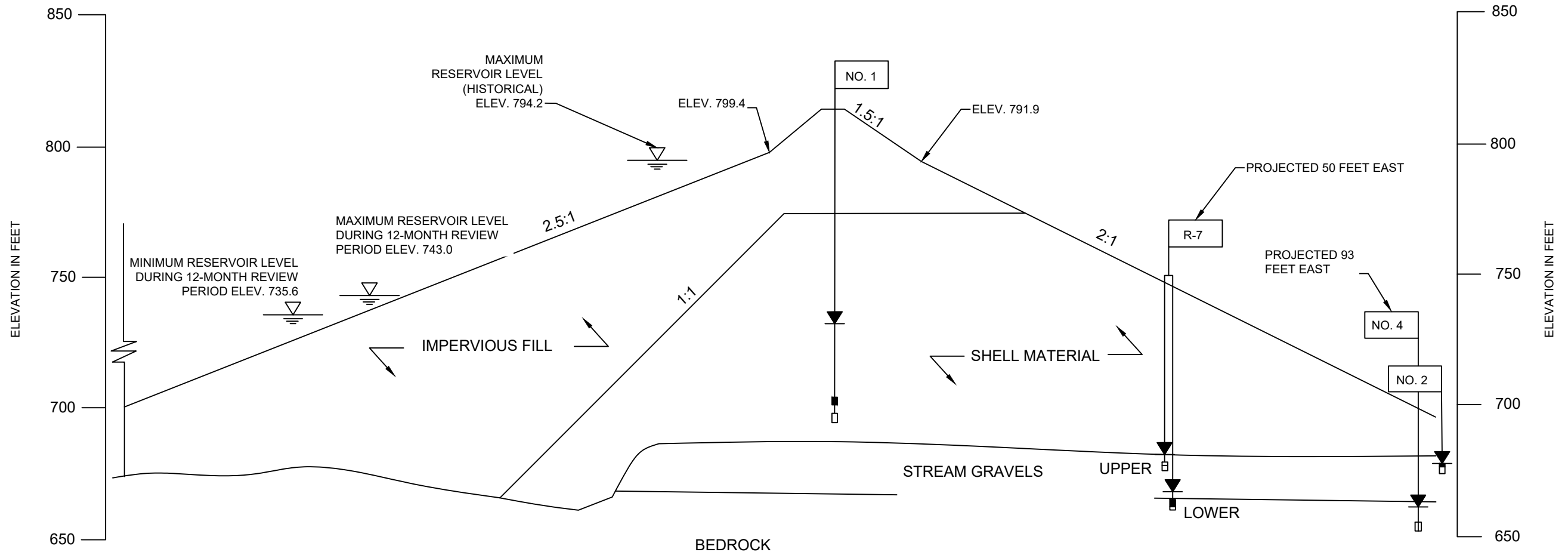

LEGEND

- R-1 PIEZOMETER (OPEN WELL TYPE)
- SURFACE OF DAM
- MAXIMUM HISTORICAL LEVEL (SINCE JANUARY 1998)
- HIGH RANGE OF MEASURED LEVELS IN PIEZOMETER DURING 12 MONTH REVIEW PERIOD
- LOW
- PIEZOMETER TIP

NOTES:

- (1) SEE FIGURE 1A FOR LOCATION OF SECTION
- (2) QUESTIONABLE READINGS ARE NOT SHOWN

**SECTION C-C'
(APPROX. STA 4+00)**

NOT TO SCALE

Annual Surveillance Report from Jan. 2021 to Dec. 2021 Santiago Creek Dam Irvine, CA		SECTION C-C'	
Irvine Ranch Water District Irvine, CA		Project 1901888	September 2022

Dam Safety Program Guideline No. 5 – Inspection Reports & Annual Surveillance Reports

1.0 Purpose

The purpose of this document is to provide guidance for dam safety Inspection Reports and Annual Surveillance Reports.

2.0 Definitions

Below is a summary of terms used herein that are related to Irvine Ranch Water District's (IRWD's) Dam Safety Program (DSP).

Annual Surveillance Report - this document is prepared once a year by the Dam Engineering Consultant and includes a comprehensive review of past surveillance reports, a compilation of field measurements, inspections, observations, and conclusions related to the general condition and safety of the dam.

DSOD Inspection Reports - this document is completed by Division of Safety of Dams (DSOD) and documents observations, recommendations, or requests for action and are typically completed on an annual basis shortly after DSOD's annual inspection.

Event Driven Inspection Report - Event driven inspections include completing the Inspection Report based on a triggering event in accordance with IRWD's DSP Guidelines.

Health Dashboard – A charted summary of the overall dam numerical rating from each monthly inspection. The dashboard is a tool that helps identify trends in the maintenance of the dam and further highlight areas of focus for the DSP Committee and maintenance staff.

Inspection Report – An IRWD documenting tool completed by operations staff on a monthly basis. The document is used to identify and record conditions of the dam and track the condition overtime. The report and its overall rating system is used to update the health dashboard.

Reports - in this guideline, "Reports" collectively refers to Annual Surveillance Reports, DSOD Inspection Reports, and Inspection Reports.

3.0 General Guidelines

There are three primary reporting tools that are used to monitor and track the performance of dams. The three reports include Inspection Reports, Annual Surveillance Reports, and DSOD Inspection Reports. These reports are considered part of routine dam safety activities and exclude special studies that are considered part of non-routine dam safety activities. Each reporting mechanism provides different degrees of inspection, frequency, perspective, and identification of action items. At times, the observations and action items can overlap between the three different reports. The below further explains the three different reporting tools.

3.1 Inspection Reports

IRWD has dam safety Inspection Forms for each of its large earthen embankment dams. The Inspection Forms include questions related to components of the dam that are routinely inspected, rated, and tracked overtime to 1) document the potential change in condition, and 2) ensure areas of concern are addressed. The forms are completed on a mobile application and the results are viewed online, either on a data portal or a PDF-generated report. The data portal and PDF-generated report include meaningful dam components such as, but not limited to, the abutments, dam crest, toe of dam, upstream side of the dam, and downstream side of the dam. The distinct and separate areas are visually represented on an exhibit included in the data portals and reports to ensure the person performing the inspection is reviewing the area that corresponds with the correct dam component. Also, prior to conducting inspections, personnel are trained on how to complete the forms in accordance with DSP Guideline No. 1. The prompts for inspection and the pre-described ranking (i.e., 0, 1, 2, and 3) correspond with the specific inspection item to review. This predefined Inspection Form structure is intended to promote consistency in the item reviewed with each Inspection Report to gain an appreciable comparison with each completed inspection. Photos are taken with the Inspection Reports and are geospatially located on the dam. The ranking system allows the reviewer to track the issue overtime to confirm the identified area of concern is being addressed. Water Operations staff, who completes the Inspection Forms, are encouraged to rotate to provide a fresh perspective on the visual observations.

Each month, a Water Operator completes the inspection survey utilizing the Survey-123 mobile application. When complete, the Water Operator submits the form, and the data is automatically transmitted to the online Data Portal. The Water Operations Supervisor and Dam Safety Engineer review the completed report and identify areas of focus.

IRWD's DSP Guideline No. 3, Seismic Monitoring, describes the seismic events that trigger an Event Driven Inspection Report that is outside the normal routine. Storm events that trigger the need to complete the Inspection Form outside the normal routine include activation of the emergency spillway, or a significant rain event.

The reporting template is updated as needed to improve clarity or to account for changing dam features. The sample paper-based Inspection Reports for each dam are included as Exhibit 5.1 to 5.5.

3.2 Annual Surveillance Reports

DSOD requires dam owners to complete and submit Annual Surveillance Reports every calendar year. At times, DSOD's annual inspection coincides with the Dam Engineering Consultant's inspection that is part of completing the Annual Surveillance Report. Generally, the annual inspections occur at different times each year to provide a new perspective on the dam since water levels fluctuate seasonally.

Dam Safety Program Guideline No. 5 – Inspection Reports & Annual Surveillance Reports

Since the condition of dams can slowly change over time, the Annual Surveillance Report is an excellent tool to understand the performance over an extended period of time and potentially identify areas of concern that could be otherwise overlooked with review of individual Inspection Reports. IRWD utilizes a Dam Engineering Consultant to prepare and complete the Annual Surveillance Report and is encouraged to consider occasionally rotate through consultants or staff preparing the report to provide a fresh perspective.

As part of the Annual Surveillance Report preparation, the Dam Engineering Consultant also receives the monthly instrumentation readings to provide a 3rd party review and interpretation of the dam performance.

3.3 DSOD Inspection Reports

DSOD conducts their own independent annual inspection at IRWD’s jurisdictional dams. The inspections include a review of all the dam components (e.g., embankment, spillway, outlet, instrumentation, etc), and documents observations, recommendations, and action items. At times, the DSOD Inspection Report may list deadlines for completing action items.

4.0 Responsibility

Various staff are responsible for completing activities related to the Inspection Reports and Annual Surveillance Reports. Table 2 summarizes the responsibilities of staff.

Table 2: Responsibilities for Inspection Reports & Annual Surveillance Reports		
Description of Responsibility	Responsible Party	Frequency/Notes
Complete and distribute routine dam safety Inspection Report	Water Operations Staff	Monthly
Complete and distribute event driven Inspection Report	Water Operations Staff	<ul style="list-style-type: none"> • For seismic events, complete in accordance with DSP Guideline No. 3. • For rain events, generally complete when activating Emergency Action Plan (EAP) for high flow condition and with significant storm events.
Review completed routine dam safety Inspection Report	Water Operations Staff, Dam Safety Engineer, Landscape Manager	Monthly
Review completed Event Driven Inspection Report	Water Operations Staff, Dam Safety Engineer	As needed
Retain and file the completed routine and event driven Inspection Report	Dam Safety Engineer	
Historize and review reporting trends	Dam Safety Engineer	Monthly

Dam Safety Program Guideline No. 5 – Inspection Reports & Annual Surveillance Reports

Determine if a significant rain event warrants an Event Driven Inspection Report	Water Operations Staff, Dam Safety Engineer	As needed
Manage preparation and completion of Annual Surveillance Reports	Dam Safety Engineer	Dam Safety Engineer manages Dam Engineering Consultant contract for completing report
Review Annual Surveillance Reports	Water Operations Manager, Dam Safety Engineer, Executive Director of Technical Services, Executive Director of Operations	
Coordinate DSOD inspections	Dam Safety Engineer	
Transmit Annual Surveillance Report to DSOD	Dam Safety Engineer	
Manage revisions to Inspection Report template	Dam Safety Engineer	
Tracks, prioritizes, and ensures completion of action items identified in Reports	Dam Safety Engineer	The Dam Safety Engineer has primary responsibility for tracking all items and ensuring the appropriate IRWD Departments are completing the action items

5.0 Exhibits

- 5.1 San Joaquin Dam Safety Inspection Report
- 5.2 Sand Canyon Dam Safety Inspection Report
- 5.3 Syphon Dam Safety Inspection Report
- 5.4 Rattlesnake Dam Safety Inspection Report
- 5.5 Santiago Creek Dam Safety Inspection Report

San Joaquin Dam Safety Inspection Report

Inspector(s): _____ Inspection Date: _____

Weather Conditions: _____ Rain Gauge Reading: _____

 Reason for Inspection: Routine/Monthly Periodic Event-Driven Photos Taken: NO YES

Additional Comments: _____

Section 1: Visual Observations

1. Reservoir and Liner	Assigned Value	1	2	3
1.1 Assessment of the reservoir area and visible watershed		No signs of erosion, sloughing, or leaned or fallen trees observed in the watershed upstream of the embankment.	Areas of minor erosion, sloughing, or leaned or fallen trees which do not impact the reservoir or storage but could pose a hazard to the reservoir or storage volume in time.	Erosion, sloughing, or landslides within the upstream watershed that have impacted the reservoir or storage volume.
1.2 Reservoir liner (vegetation)		Liner is free of vegetation and weeds such that the face of the liner is clearly visible from the established inspection routes. No woody vegetation observed.	Vegetation or weeds which impedes up to 25% of the visual inspection of the liner and limits observation of the liner from the established inspection routes or woody vegetation is observed.	Vegetation which impedes greater than 25% of the visual inspection of the liner and limits observation of the liner from the established inspection routes.
1.3 Reservoir liner (structural)		No signs of structural distress (settlement, erosion, damage to the concrete).	Potential signs of structural distress (settlement, erosion, damage to the concrete).	Signs of structural distress (settlement, erosion, damage to the concrete).
1.4 Reservoir liner (settlement, sinkholes, or other depressions)		No sinkholes, depressions, or settlement observed.	Sinkhole, depression, or vertical settlement 6 inches or less in depth and less than 3 feet in diameter observed.	Sinkhole, depression, or vertical settlement greater than 6 inches in depth or greater than 3 feet in diameter observed.
1.5 Reservoir liner (seepage)		No evidence of damp areas or visible seepage.	Damp areas or seepage with clear water indicating no sediment transport through the liner.	Damp areas or seepage with cloudy water indicating sediment transport through the liner.
1.6 Reservoir inlet structure		No signs of structural distress	Potential signs of structural distress.	Signs of structural distress.

San Joaquin Dam Safety Inspection Report

2. Dam Crest and Inlet Structure, Left Side	Assigned Value	1	2	3
2.1 Cracking		No cracks or minor surficial cracks less than ¼" wide that have no observable pattern indicative of slope movement or failure.	Cracking greater than ¼" wide along the embankment crest, or along the alignment of pipes which may indicate a new or progressing instability of the embankment.	Cracking greater than ¼" wide that is progressing or changing along the embankment crest, or along the alignment of pipes that may indicate an active instability of the embankment.
2.2 Vegetation		Liner is free of weeds and trash. No shrubs or trees observed growing in the liner.	Weeds or trash observed on the liner.	Shrubs or trees growing in the liner.
2.3 Spillway inlet (structural)		No signs of structural distress (settlement, erosion, damage to the concrete, corrosion on the grate).	Potential signs of structural distress (settlement, erosion, damage to the concrete, corrosion on the grate).	Signs of structural distress (settlement, erosion, damage to the concrete, corrosion on the grate).
2.4 Spillway inlet (flow)		Inlet is clear of debris that would inhibit flow.	Inlet is blocked by debris, but the blockage is likely to be washed away in a high flow event.	Inlet may become blocked such that flow capacity would be impeded during a high flow event or greater than 25% of the spillway could be blocked by vegetation or other obstructions. Woody vegetation is observed.
2.5 Animal burrows or other damage from wildlife		No evidence of animal burrows or other damage caused by wildlife observed. Animal deterrent boxes are filled with poison.	Animal burrows less than 6 inches in depth anywhere on the slope of the embankment without visible signs of seepage, or embankment distress (e.g., cracking slumping, settlement). Animal deterrent boxes are lacking poison.	Animal burrows greater than 6 inches in depth observed anywhere on the slope of the embankment or animal burrows are observed with visible signs of seepage, or embankment distress (e.g., cracking slumping, settlement).

3. Downstream Embankment, Upper Section	Assigned Value	1	2	3
3.1 Seepage		No evidence of damp areas, seepage, or areas which are significantly "greener" or have flourishing vegetation.	Damp areas, seepage, or areas which are significantly "greener" or have flourishing vegetation and clear water indicating no sediment transport through the embankment.	Damp areas, seepage, or areas which are significantly "greener" or have flourishing vegetation and cloudy water indicating sediment transport through the embankment.
3.2 Cracking		No cracks or minor surficial cracks less than ¼" wide that have no observable pattern indicative of slope movement or failure.	Cracking greater than ¼" wide along the embankment crest, or along the alignment of pipes which indicate a new or progressing instability of the embankment.	Cracking greater than ¼" wide that is progressing or changing along the embankment crest, or along the alignment of pipes indicating an active instability of the embankment.
3.3 Settlement, sinkholes, or other depressions (enhanced risk along pipe alignments)		No sinkholes, depressions, or settlement observed.	Dry sinkhole, depression, or vertical settlement 6 inches or less in depth and less than 3 feet in diameter observed.	Dry sinkhole, depression, or vertical settlement greater than 6 inches in depth or greater than 3 feet in diameter observed or any sinkhole, depression, or vertical settlement which has moisture, seepage, or flow present.
3.4 Sliding, sloughing, or bulging (other slope movements)		No evidence of sliding, sloughing, or bulging.	Evidence of sliding, sloughing, or bulging that does not involve the entire downstream slope of the embankment.	Evidence of sliding, sloughing, or bulging which involves the entire slope of the embankment from crest to toe.
3.5 Surface erosion		No erosion observed on the embankment.	Areas of minor erosion observed along downstream slope of the embankment less than 6 inches deep and less than 1 foot wide.	Erosion of the downstream face or the embankment which is greater than 6 inches deep or greater than 1 foot wide or that has the potential to back cut into the crest of the embankment.
3.6 Vegetation		Weeds or grasses are maintained at 6 inches in height or less. No woody vegetation observed. Embankment is free of vegetation such that the face of the embankment is clearly visible from the established inspection routes.	Weeds or grasses are greater than 6 inches in height. Vegetation which impedes up to 25% of the visual inspection of the embankment and limits observation of the embankment from the established inspection routes or woody vegetation is observed.	Vegetation which impedes greater than 25% of the visual inspection of the embankment and limits observation of the embankment from the established inspection routes.
3.7 Animal burrows or other damage from wildlife		No evidence of animal burrows or other damage caused by wildlife observed. Animal deterrent boxes are filled with poison.	Animal burrows less than 6 inches in depth anywhere on the slope of the embankment without visible signs of seepage, or embankment distress (e.g., cracking slumping, settlement). Animal deterrent boxes are lacking poison.	Animal burrows greater than 6 inches in depth observed anywhere on the slope of the embankment or animal burrows are observed with visible signs of seepage, or embankment distress (e.g., cracking slumping, settlement).

San Joaquin Dam Safety Inspection Report

4. Left Abutment	Assigned Value	1	2	3
4.1 Seepage		No evidence of damp areas, seepage, or areas which are significantly "greener" or have flourishing vegetation.	Damp areas, seepage, or areas which are significantly "greener" or have flourishing vegetation and clear water indicating no sediment transport through the abutment.	Damp areas, seepage, or areas which are significantly "greener" or have flourishing vegetation and cloudy water indicating sediment transport through the abutment.
4.2 Cracking		No cracks or minor surficial cracks less than ¼" wide that have no observable pattern indicative of slope movement or failure.	Cracking greater than ¼" wide along the abutment, which indicate a new or progressing instability of the abutment.	Cracking greater than ¼" wide that is progressing or changing along the abutment.
4.3 Settlement, sinkholes, or other depressions (enhanced risk along pipe alignments)		No sinkholes, depressions, or settlement observed.	Dry sinkhole, depression, or vertical settlement 6 inches or less in depth and less than 3 feet in diameter observed.	Dry sinkhole, depression, or vertical settlement greater than 6 inches in depth or greater than 3 feet in diameter observed or any sinkhole, depression, or vertical settlement which has moisture, seepage, or flow present.
4.4 Sliding, sloughing, or bulging (other slope movements)		No evidence of sliding, sloughing, or bulging.	Evidence of sliding, sloughing, or bulging that does not involve the entire slope of the abutment and may be observed after periods of heavy rain which saturate the upper surface of the abutment.	Evidence of sliding, sloughing, or bulging which involves the entire slope of the abutment from crest to toe, indicating a large instability of the abutment.
4.5 Surface erosion		No erosion observed on the abutment.	Areas of minor erosion observed along the abutment less than 6 inches deep and less than 1 foot wide.	Erosion of the abutment which is greater than 6 inches deep or greater than 1 foot wide or that has the potential to back cut into the crest of the embankment.
4.6 Abutment drains		No debris or vegetation observed in the abutment drain.	Debris and vegetation obstructing less than half of the capacity in the abutment drain. Debris observed will wash away in an event where half of the capacity of the drain is required.	Significant debris or vegetation is present in the abutment drain that could significantly compromise the performance of the abutment drain.
4.7 Animal burrows or other damage from wildlife		No evidence of animal burrows or other damage caused by wildlife observed. Animal deterrent boxes are filled with poison.	Animal burrows less than 6 inches in depth anywhere on the slope of the embankment without visible signs of seepage, or embankment distress (e.g., cracking slumping, settlement). Animal deterrent boxes are lacking poison.	Animal burrows greater than 6 inches in depth observed anywhere on the slope of the embankment or animal burrows are observed with visible signs of seepage, or embankment distress (e.g., cracking slumping, settlement).

San Joaquin Dam Safety Inspection Report

5. Dam Crest and Inlet Structure, Right Side	Assigned Value	1	2	3
5.1 Cracking		No cracks or minor surficial cracks less than ¼" wide that have no observable pattern indicative of slope movement or failure.	Cracking greater than ¼" wide along the embankment crest, or along the alignment of pipes which indicate a new or progressing instability of the embankment.	Cracking greater than ¼" wide that is progressing or changing along the embankment crest, or along the alignment of pipes indicating an active instability of the embankment.
5.2 Vegetation		Liner is free of weeds and trash. No shrubs or trees observed growing in the liner.	Weeds or trash observed on the liner.	Shrubs or trees growing in the liner.
5.3 Spillway inlet (structural)		Visible inlet structure does not show signs of distress including settlement, or erosion at the base of the structure. No signs of damage to the concrete base and the steel cage shows no signs of corrosion.	2 inches or less of settlement or erosion around the concrete base observed. Concrete base has limited spalling or cracking. Steel cage shows signs of localized corrosion.	Greater than 2 inches of settlement or erosion around the concrete base observed. Concrete base has widespread spalling or cracking. Steel cage shows signs of widespread corrosion.
5.4 Spillway inlet (flow)		Inlet is clear of debris that would inhibit flow.	Inlet is blocked by debris, but the blockage is likely to be washed away in a high flow event.	Inlet may become blocked such that flow capacity would be impeded during a high flow event or greater than 25% of the spillway could be blocked by vegetation or other obstructions. Woody vegetation is observed.
5.5 Animal burrows or other damage from wildlife		No evidence of animal burrows or other damage caused by wildlife observed. Animal deterrent boxes are filled with poison.	Animal burrows less than 6 inches in depth anywhere on the slope of the embankment without visible signs of seepage, or embankment distress (e.g., cracking slumping, settlement). Animal deterrent boxes are lacking poison.	Animal burrows greater than 6 inches in depth observed anywhere on the slope of the embankment or animal burrows are observed with visible signs of seepage, or embankment distress (e.g., cracking slumping, settlement).

San Joaquin Dam Safety Inspection Report

6. Downstream Embankment, Middle Section	Assigned Value	1	2	3
6.1 Seepage		No evidence of damp areas, seepage, or areas which are significantly "greener" or have flourishing vegetation.	Damp areas, seepage, or areas which are significantly "greener" or have flourishing vegetation and clear water indicating no sediment transport through the embankment.	Damp areas, seepage, or areas which are significantly "greener" or have flourishing vegetation and cloudy water indicating sediment transport through the embankment.
6.2 Cracking		No cracks or minor surficial cracks less than ¼" wide that have no observable pattern indicative of slope movement or failure.	Cracking greater than ¼" wide along the embankment crest, or along the alignment of pipes which indicate a new or progressing instability of the embankment.	Cracking greater than ¼" wide that is progressing or changing along the embankment crest, or along the alignment of pipes indicating an active instability of the embankment.
6.3 Settlement, sinkholes, or other depressions (enhanced risk along pipe alignments)		No sinkholes, depressions, or settlement observed.	Dry sinkhole, depression, or vertical settlement 6 inches or less in depth and less than 3 feet in diameter observed.	Dry sinkhole, depression, or vertical settlement greater than 6 inches in depth or greater than 3 feet in diameter observed or any sinkhole, depression, or vertical settlement which has moisture, seepage, or flow present.
6.4 Sliding, sloughing, or bulging (other slope movements)		No evidence of sliding, sloughing, or bulging.	Evidence of sliding, sloughing, or bulging that does not involve the entire downstream slope of the embankment and may be observed after periods of heavy rain which saturate the upper surface of the embankment.	Evidence of sliding, sloughing, or bulging which involves the entire slope of the embankment from crest to toe, indicating a large instability of the embankment.
6.5 Surface erosion		No erosion observed on the embankment.	Areas of minor erosion observed along downstream slope of the embankment less than 6 inches deep and less than 1 foot wide.	Erosion of the downstream face or the embankment which is greater than 6 inches deep or greater than 1 foot wide or that has the potential to back cut into the crest of the embankment.
6.6 Vegetation		Weeds or grasses are maintained at 6 inches in height or less. No woody vegetation observed. Embankment is free of vegetation such that the face of the embankment is clearly visible from the established inspection routes.	Weeds or grasses are greater than 6 inches in height. Vegetation which impedes up to 25% of the visual inspection of the embankment and limits observation of the embankment from the established inspection routes or woody vegetation is observed.	Vegetation which impedes greater than 25% of the visual inspection of the embankment and limits observation of the embankment from the established inspection routes.
6.7 Animal burrows or other damage from wildlife		No evidence of animal burrows or other damage caused by wildlife observed. Animal deterrent boxes are filled with poison.	Animal burrows less than 6 inches in depth anywhere on the slope of the embankment without visible signs of seepage, or embankment distress (e.g., cracking slumping, settlement). Animal deterrent boxes are lacking poison.	Animal burrows greater than 6 inches in depth observed anywhere on the slope of the embankment or animal burrows are observed with visible signs of seepage, or embankment distress (e.g., cracking slumping, settlement).

San Joaquin Dam Safety Inspection Report

7. Right Abutment	Assigned Value	1	2	3
7.1 Seepage		No evidence of damp areas, seepage, or areas which are significantly "greener" or have flourishing vegetation.	Damp areas, seepage, or areas which are significantly "greener" or have flourishing vegetation and clear water indicating no sediment transport through the abutment.	Damp areas, seepage, or areas which are significantly "greener" or have flourishing vegetation and cloudy water indicating sediment transport through the abutment.
7.2 Cracking		No cracks or minor surficial cracks less than ¼" wide that have no observable pattern indicative of slope movement or failure.	Cracking greater than ¼" wide along the abutment, or in a horseshoe shape on the abutment slope, which indicate a new or progressing instability of the abutment.	Cracking greater than ¼" wide that is progressing or changing along the abutment, or in a horseshoe shape on the abutment slope.
7.3 Settlement, sinkholes, or other depressions (enhanced risk along pipe alignments)		No sinkholes, depressions, or settlement observed.	Dry sinkhole, depression, or vertical settlement 6 inches or less in depth and less than 3 feet in diameter observed.	Dry sinkhole, depression, or vertical settlement greater than 6 inches in depth or greater than 3 feet in diameter observed or any sinkhole, depression, or vertical settlement which has moisture, seepage, or flow present.
7.4 Sliding, sloughing, or bulging (other slope movements)		No evidence of sliding, sloughing, or bulging.	Evidence of sliding, sloughing, or bulging that is small, shallow, or does not involve the entire slope of the abutment and may be observed after periods of heavy rain which saturate the upper surface of the abutment.	Evidence of sliding, sloughing, or bulging which involves the entire slope of the abutment from crest to toe, indicating a large instability of the abutment.
7.5 Surface erosion		No erosion observed on the abutment.	Areas of minor erosion observed along the abutment less than 6 inches deep and less than 1 foot wide.	Erosion of the abutment which is greater than 6 inches deep or greater than 1 foot wide or that has the potential to back cut into the crest of the embankment.
7.6 Abutment drains		No debris or vegetation observed in the abutment drain.	Debris and vegetation obstructing less than ½ of the capacity in the abutment drain. Debris observed will wash away in an event where half of the capacity of the drain is required.	Significant debris or vegetation is present in the abutment drain that could significantly compromise the performance of the abutment drain.
7.7 Animal burrows or other damage from wildlife		No evidence of animal burrows or other damage caused by wildlife observed. Animal deterrent boxes are filled with poison.	Animal burrows less than 6 inches in depth anywhere on the slope of the embankment without visible signs of seepage, or embankment distress (e.g., cracking slumping, settlement). Animal deterrent boxes are lacking poison.	Animal burrows greater than 6 inches in depth observed anywhere on the slope of the embankment or animal burrows are observed with visible signs of seepage, or embankment distress (e.g., cracking slumping, settlement).

San Joaquin Dam Safety Inspection Report

8. Downstream Embankment, Lower Section	Assigned Value	1	2	3
8.1 Seepage		No evidence of damp areas, seepage, or areas which are significantly "greener" or have flourishing vegetation.	Damp areas, seepage, or areas which are significantly "greener" or have flourishing vegetation and clear water indicating no sediment transport through the embankment.	Damp areas, seepage, or areas which are significantly "greener" or have flourishing vegetation and cloudy water indicating sediment transport through the embankment.
8.2 Cracking		No cracks or minor surficial cracks less than ¼" wide that have no observable pattern indicative of slope movement or failure.	Cracking greater than ¼" wide along the embankment crest, or along the alignment of pipes which indicate a new or progressing instability of the embankment.	Cracking greater than ¼" wide that is progressing or changing along the embankment crest, or along the alignment of pipes indicating an active instability of the embankment.
8.3 Settlement, sinkholes, or other depressions (enhanced risk along pipe alignments)		No sinkholes, depressions, or settlement observed.	Dry sinkhole, depression, or vertical settlement 6 inches or less in depth and less than 3 feet in diameter observed.	Dry sinkhole, depression, or vertical settlement greater than 6 inches in depth or greater than 3 feet in diameter observed or any sinkhole, depression, or vertical settlement which has moisture, seepage, or flow present.
8.4 Sliding, sloughing, or bulging (other slope movements)		No evidence of sliding, sloughing, or bulging.	Evidence of sliding, sloughing, or bulging that does not involve the entire downstream slope of the embankment and may be observed after periods of heavy rain which saturate the upper surface of the embankment.	Evidence of sliding, sloughing, or bulging which involves the entire slope of the embankment from crest to toe, indicating a large instability of the embankment.
8.5 Surface erosion		No erosion observed on the embankment.	Areas of minor erosion observed along downstream slope of the embankment less than 6 inches deep and less than 1 foot wide.	Erosion of the downstream face or the embankment which is greater than 6 inches deep or greater than 1 foot wide or that has the potential to back cut into the crest of the embankment.
8.6 Vegetation		Weeds or grasses are maintained at 6 inches in height or less. No woody vegetation observed. Embankment is free of vegetation such that the face of the embankment is clearly visible from the established inspection routes.	Weeds or grasses are greater than 6 inches in height. Vegetation which impedes up to 25% of the visual inspection of the embankment and limits observation of the embankment from the established inspection routes or woody vegetation is observed.	Vegetation which impedes greater than 25% of the visual inspection of the embankment and limits observation of the embankment from the established inspection routes.
8.7 Animal burrows or other damage from wildlife		No evidence of animal burrows or other damage caused by wildlife observed. Animal deterrent boxes are filled with poison.	Animal burrows less than 6 inches in depth anywhere on the slope of the embankment without visible signs of seepage, or embankment distress (e.g., cracking slumping, settlement). Animal deterrent boxes are lacking poison.	Animal burrows greater than 6 inches in depth observed anywhere on the slope of the embankment or animal burrows are observed with visible signs of seepage, or embankment distress (e.g., cracking slumping, settlement).

San Joaquin Dam Safety Inspection Report

9. Toe of Dam, Right Side	Assigned Value	1	2	3
9.1 Seepage, boils, or standing water at or beyond the toe of the embankment		No evidence of seepage, boils, or standing water observed at or beyond the toe of the embankment.	Small, damp areas observed at or beyond the toe of the embankment observed. Areas of seepage around the toe of the embankment during "sunny day" conditions and clear water indicating no sediment transport around the spillway.	Seepage, boils, or standing water at or beyond the toe of the embankment observed. Active seepage observed at the toe of the embankment during "sunny day" conditions and cloudy water indicating sediment transport.
9.2 Cracking		No cracks or minor surficial cracks less than 1/4" wide that have no observable pattern indicative of movement along a buried pipe.	Cracking greater than 1/4" wide along a buried pipe which indicate a new or progressing instability along the buried pipe.	Cracking greater than 1/4" wide that is progressing or changing along the buried pipe indicating an active instability of the embankment.
9.3 Heave or uplift at or beyond the toe of the embankment		No heave or uplift at or beyond the toe of the embankment observed.	Localized areas of heave or uplift that are unlikely to be associated with embankment instability.	Areas of heave or uplift that indicate a potential large-scale instability of the embankment.
9.4 Settlement, sinkholes, or other depressions (enhanced risk along pipe alignments)		No sinkholes, depressions, or settlement observed.	Dry sinkhole, depression, or vertical settlement 6 inches or less in depth and less than 3 feet in diameter observed.	Dry sinkhole, depression, or vertical settlement greater than 6 inches in depth or greater than 3 feet in diameter observed or any sinkhole, depression, or vertical settlement which has moisture, seepage, or flow present.
9.5 Visible parts of drainage system		Discharge pipes have no corrosion.	Discharge pipes have minor corrosion, but full function of the system remains.	Discharge pipes have major corrosion and function of the system is impaired.
9.6 Animal burrows or other damage from wildlife		No evidence of animal burrows or other damage caused by wildlife observed. Animal deterrent boxes are filled with poison.	Animal burrows less than 6 inches in depth anywhere on the slope of the embankment without visible signs of seepage, or embankment distress (e.g., cracking slumping, settlement). Animal deterrent boxes are lacking poison.	Animal burrows greater than 6 inches in depth observed anywhere on the slope of the embankment or animal burrows are observed with visible signs of seepage, or embankment distress (e.g., cracking slumping, settlement).

San Joaquin Dam Safety Inspection Report

10. Toe of Dam, Left Side	Assigned Value	1	2	3
10.1 Seepage, boils, or standing water at or beyond the toe of the embankment		No evidence of seepage, boils, or standing water observed at or beyond the toe of the embankment.	Small, damp areas observed at or beyond the toe of the embankment observed. Areas of seepage around the toe of the embankment during “sunny day” conditions and clear water indicating no sediment transport around the spillway.	Seepage, boils, or standing water at or beyond the toe of the embankment observed. Active seepage observed at the toe of the embankment during “sunny day” conditions and cloudy water indicating sediment transport.
10.2 Cracking		No cracks or minor surficial cracks less than ¼” wide that have no observable pattern indicative of movement along a buried pipe.	Cracking greater than ¼” wide along a buried pipe which indicate a new or progressing instability along the buried pipe.	Cracking greater than ¼” wide that is progressing or changing along the buried pipe indicating an active instability of the embankment.
10.3 Heave or uplift at or beyond the toe of the embankment		No heave or uplift at or beyond the toe of the embankment observed.	Localized areas of heave or uplift that are unlikely to be associated with embankment instability.	Areas of heave or uplift that indicate a potential large-scale instability of the embankment.
10.4 Settlement, sinkholes, or other depressions (enhanced risk along pipe alignments)		No sinkholes, depressions, or settlement observed.	Dry sinkhole, depression, or vertical settlement 6 inches or less in depth and less than 3 feet in diameter observed.	Dry sinkhole, depression, or vertical settlement greater than 6 inches in depth or greater than 3 feet in diameter observed or any sinkhole, depression, or vertical settlement which has moisture, seepage, or flow present.
10.5 Animal burrows or other damage from wildlife		No evidence of animal burrows or other damage caused by wildlife observed. Animal deterrent boxes are filled with poison.	Animal burrows less than 6 inches in depth anywhere on the slope of the embankment without visible signs of seepage, or embankment distress (e.g., cracking slumping, settlement). Animal deterrent boxes are lacking poison.	Animal burrows greater than 6 inches in depth observed anywhere on the slope of the embankment or animal burrows are observed with visible signs of seepage, or embankment distress (e.g., cracking slumping, settlement).
10.6 Visible parts of drainage system		Discharge pipes have no corrosion.	Discharge pipes have minor corrosion, but full function of the system remains.	Discharge pipes have major corrosion and function of the system is impaired.
10.7 Visible parts of spillway outlet pipes		Spillway outlet pipes have no corrosion.	Spillway outlet pipes have minor corrosion, but full function of the system remains.	Spillway outlet pipes have major corrosion and function of the system is impaired.
10.8 Concrete condition of the inside of the spillway outlet structure		Negligible joint movement, cracking, pitting, breakage, or spalling.	Localized spalling, scaling, or cracking observed.	Widespread spalling, scaling, or cracking present.
10.9 Erosion or undermining at spillway outlet structure		No active erosion or scouring around the concrete structures.	Localized areas of erosion or scouring around the concrete structures less than 1 foot deep in any direction.	Widespread erosion or scouring leading to large or long unsupported sections of concrete.
10.10 Seepage around or underneath spillway outlet structure		No evidence of seepage, damp areas, or boils are observed around the spillway alignment or beneath spillway slabs.	Areas of seepage around the spillway or flow at the toe of the spillway prior to a spill event and during “sunny day” conditions and clear water indicating no sediment transport around the spillway.	Active seepage observed outside of the spillway or at the toe of the spillway prior to a spill event and during “sunny day” conditions and cloudy water indicating sediment transport.



Section 2: Instrumentation Observations and Measurements

Crack measurements, drain and seepage flows, and instrumentation readings are not recorded on this report, they are tracked by IRWD Operations staff using Microsoft Teams and spreadsheets.

Table with 4 columns: Yes, No, Unknown, N/A. Rows include Reservoir / Upstream, Drainage Elements and Weirs, and Piezometers and Groundwater Levels.

Section 3: Annual or Periodic Inspection

Table with 4 columns: Yes, No, Unknown, N/A. Includes a sub-header for Inspection Items and 8 numbered items.

Section 4: Event Driven Inspection

Event driven inspections include observations following earthquake or storm events. These inspections are performed based on the event thresholds established by IRWD.

Table with 4 columns: Yes, No, Unknown, N/A. Rows include Earthquake (with sub-questions and a form line) and Precipitation.



Section 5: Notes and Comments

Section 6: Items that require further action, attention, or monitoring (assigned values 2 or 3)

Item	Comment	Action	Confirmation # (if applicable)

Section 7: Sign Off

Changed Conditions

	Yes	No	Unknown	N/A
Have any conditions changed since the previous inspection?	<input type="checkbox"/>	<input type="checkbox"/>	<input type="checkbox"/>	<input type="checkbox"/>
Have areas of distress been identified during this inspection?	<input type="checkbox"/>	<input type="checkbox"/>	<input type="checkbox"/>	<input type="checkbox"/>

Water Operations Inspector: _____ Signature: _____ Date: _____

Water Operations Supervisor: _____ Signature: _____ Date: _____

Dam Safety Engineer: _____ Signature: _____ Date: _____

Legend

- A Piezometer
- A Monitoring Well
- A Pneumatic Piezometer
- ◆ Rain Gauge
- ▼ Spillway Inlet
- Spillway Outlet
- Emergency Outlet
- ⬠ Seepage Collection Vault
- Silt Collection Vault
- # Area Number
- Left Abutment
- Right Abutment
- Dam Crest and Inlet Structure, Left Side
- Dam Crest and Inlet Structure, Right Side
- Toe of Dam, Left Side
- Toe of Dam, Right Side
- Downstream Embankment, Upper Section
- Downstream Embankment, Middle Section
- Downstream Dam Embankment Slope Lower Section



Notes
 1. Coordinate System: NAD 1983 StatePlane California VI FIPS 0406 Feet
 2. Data Sources: IRWD, Stantec
 3. Background: NAIP Imagery

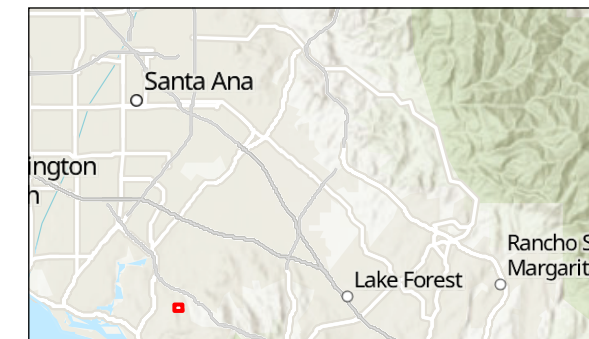
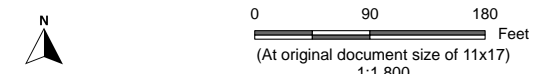

Project Location
 Irvine, CA
 Prepared by CS on 2/24/2023
 TR by CB on 2/24/2023
 IR by MD on 2/24/2023

Client/Project
 Irvine Ranch Water District
 Dam Safety Program

Figure No.
 1

Title
 San Joaquin Dam Overview

C:\Users\cstege\OneDrive - Stantec\Desktop\IRWD_Export\IRWD_Figures\IRWD_Figures.aprx Dam_Overview Revised: 2023-05-24 By: cstege

Legend

- | | | | |
|---|--------------------------|---|---|
| A | Piezometer | ■ | Left Abutment |
| A | Monitoring Well | ■ | Right Abutment |
| A | Pneumatic Piezometer | ■ | Dam Crest and Inlet Structure, Left Side |
| ◆ | Rain Gauge | ■ | Dam Crest and Inlet Structure, Right Side |
| ▲ | Aeration System | ■ | Toe of Dam, Left Side |
| ▼ | Spillway Inlet | ■ | Toe of Dam, Right Side |
| ● | Spillway Outlet | ■ | Downstream |
| ■ | Emergency Outlet | ■ | Embankment, Upper Section |
| ● | Reservoir Inlet | ■ | Downstream |
| ■ | Seepage Collection Vault | ■ | Embankment, Middle Section |
| ● | Silt Collection Vault | ■ | Downstream Dam |
| | | ■ | Embankment Slope Lower Section |



- Notes**
1. Coordinate System: NAD 1983 StatePlane California VI FIPS 0406 Feet
 2. Data Sources: IRWD, Stantec
 3. Background: NAIP Imagery

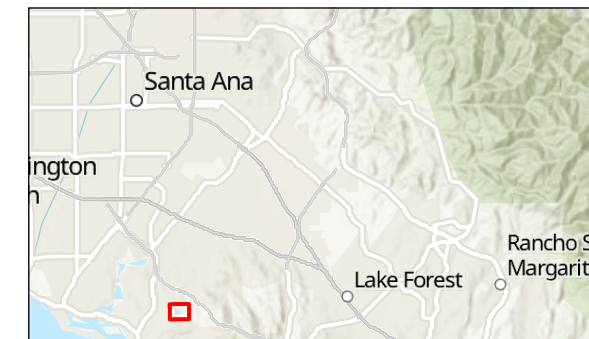
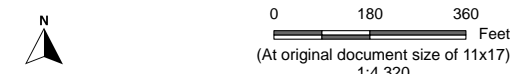

Project Location
Irvine, CA

Prepared by CS on 2/24/2023
TR by CB on 2/24/2023
IR by MD on 2/24/2023

Client/Project
Irvine Ranch Water District
Dam Safety Program

Figure No.
2

Title
San Joaquin Dam Overview

Sand Canyon Dam Safety Inspection Report

Inspector(s): _____ Inspection Date: _____
 Weather Conditions: _____ Rain Gauge Reading: _____
 Reason for Inspection: Routine/Monthly Periodic Event-Driven Photos Taken: NO YES
 Additional Comments: _____

Section 1: Visual Observations

1. Reservoir	Assigned Value	1	2	3
1.1 Assessment of the reservoir area and visible watershed.		No signs of erosion, sloughing, or leaned or fallen trees observed in the watershed upstream of the embankment.	Areas of minor erosion, sloughing, or leaned or fallen trees which do not impact the reservoir or storage but could pose a hazard to the reservoir or storage volume in time.	Erosion, sloughing, or landslides within the upstream watershed that have impacted the reservoir or storage volume.
2. Dam Crest and Upstream Embankment, Left Side	Assigned Value	1	2	3
2.1 Cracking		No cracks or minor surficial cracks less than ¼" wide that have no observable pattern indicative of slope movement or failure.	Cracking greater than ¼" wide along the embankment crest, or along the alignment of pipes which may indicate a new or progressing instability of the embankment.	Cracking greater than ¼" wide that is progressing or changing along the embankment crest, or along the alignment of pipes that may indicate an active instability of the embankment.
2.2 Vegetation		Liner is free of weeds and trash. No shrubs or trees observed growing in the liner.	Weeds or trash observed on the liner.	Shrubs or trees growing in the liner.
2.3 Settlement, sinkholes, or other depressions (enhanced risk along pipe alignments)		No sinkholes, depressions, or settlement observed.	Sinkhole, depression, or vertical settlement 6 inches or less in depth and less than 3 feet in diameter observed.	Sinkhole, depression, or vertical settlement greater than 6 inches in depth or greater than 3 feet in diameter observed.
2.4 Animal burrows or other damage from wildlife		No evidence of animal burrows or other damage caused by wildlife observed. Animal deterrent boxes are filled with poison.	Animal burrows less than 6 inches in depth anywhere on the slope of the embankment without visible signs of seepage, or embankment distress (e.g., cracking slumping, settlement). Animal deterrent boxes are lacking poison.	Animal burrows greater than 6 inches in depth observed anywhere on the slope of the embankment or animal burrows are observed with visible signs of seepage, or embankment distress (e.g., cracking slumping, settlement).

Sand Canyon Dam Safety Inspection Report

3. Downstream Embankment, Left Side	Assigned Value	1	2	3
3.1 Seepage		No evidence of damp areas, seepage, or areas which are significantly "greener" or have flourishing vegetation.	Damp areas, seepage, or areas which are significantly "greener" or have flourishing vegetation and clear water indicating no sediment transport through the embankment.	Damp areas, of seepage, or areas which are significantly "greener" or have flourishing vegetation and cloudy water indicating sediment transport through the embankment.
3.2 Cracking		No cracks or minor surficial cracks less than ¼" wide that have no observable pattern indicative of slope movement or failure.	Cracking greater than ¼" wide along the embankment crest, or along the alignment of pipes which indicate a new or progressing instability of the embankment.	Cracking greater than ¼" wide that is progressing or changing along the embankment crest, or along the alignment of pipes indicating an active instability of the embankment.
3.3 Settlement, sinkholes, or other depressions (enhanced risk along pipe alignments)		No sinkholes, depressions, or settlement observed.	Dry sinkhole, depression, or vertical settlement 6 inches or less in depth and less than 3 feet in diameter observed.	Dry sinkhole, depression, or vertical settlement greater than 6 inches in depth or greater than 3 feet in diameter observed or any sinkhole, depression, or vertical settlement which has moisture, seepage, or flow present.
3.4 Sliding, sloughing, or bulging (other slope movements)		No evidence of sliding, sloughing, or bulging.	Evidence of sliding, sloughing, or bulging that does not involve the entire downstream slope of the embankment.	Evidence of sliding, sloughing, or bulging which involves the entire slope of the embankment from crest to toe.
3.5 Surface erosion		No erosion observed on the embankment.	Areas of minor erosion observed along downstream slope of the embankment less than 6 inches deep and less than 1 foot wide.	Erosion of the downstream face or the embankment which is greater than 6 inches deep or greater than 1 foot wide or that has the potential to back cut into the crest of the embankment.
3.6 Vegetation		Weeds or grasses are maintained at 6 inches in height or less. No woody vegetation observed. Embankment is free of vegetation such that the face of the embankment is clearly visible from the established inspection routes.	Weeds or grasses are greater than 6 inches in height. Vegetation which impedes up to 25% of the visual inspection of the embankment and limits observation of the embankment from the established inspection routes or woody vegetation is observed.	Vegetation which impedes greater than 25% of the visual inspection of the embankment and limits observation of the embankment from the established inspection routes.
3.7 Animal burrows or other damage from wildlife		No evidence of animal burrows or other damage caused by wildlife observed. Animal deterrent boxes are filled with poison.	Animal burrows less than 6 inches in depth anywhere on the slope of the embankment without visible signs of seepage, or embankment distress (e.g., cracking slumping, settlement). Animal deterrent boxes are lacking poison.	Animal burrows greater than 6 inches in depth observed anywhere on the slope of the embankment or animal burrows are observed with visible signs of seepage, or embankment distress (e.g., cracking slumping, settlement).

Sand Canyon Dam Safety Inspection Report

4. Left Abutment	Assigned Value	1	2	3
4.1 Seepage		No evidence of damp areas, seepage, or areas which are significantly "greener" or have flourishing vegetation.	Damp areas, seepage, or areas which are significantly "greener" or have flourishing vegetation and clear water indicating no sediment transport through the abutment.	Damp areas, seepage, or areas which are significantly "greener" or have flourishing vegetation and cloudy water indicating sediment transport through the abutment.
4.2 Cracking		No cracks or minor surficial cracks less than ¼" wide that have no observable pattern indicative of slope movement or failure.	Cracking greater than ¼" wide along the abutment, which indicate a new or progressing instability of the abutment.	Cracking greater than ¼" wide that is progressing or changing along the abutment.
4.3 Settlement, sinkholes, or other depressions (enhanced risk along pipe alignments)		No sinkholes, depressions, or settlement observed.	Dry sinkhole, depression, or vertical settlement 6 inches or less in depth and less than 3 feet in diameter observed.	Dry sinkhole, depression, or vertical settlement greater than 6 inches in depth or greater than 3 feet in diameter observed or any sinkhole, depression, or vertical settlement which has moisture, seepage, or flow present.
4.4 Sliding, sloughing, or bulging (other slope movements)		No evidence of sliding, sloughing, or bulging.	Evidence of sliding, sloughing, or bulging that is small, shallow, or does not involve the entire slope of the abutment.	Evidence of sliding, sloughing, or bulging which involves the entire slope of the abutment from dam crest to toe.
4.5 Surface erosion		No erosion observed on the abutment.	Areas of minor erosion observed along the abutment less than 6 inches deep and less than 1 foot wide.	Erosion of the abutment which is greater than 6 inches deep or greater than 1 foot wide or that has the potential to back cut into the crest of the embankment.
4.6 Abutment drains		No debris or vegetation observed in the abutment drain.	Debris and vegetation obstructing less than half of the capacity in the abutment drain. Debris observed will wash away in an event where half of the capacity of the drain is required.	Significant debris or vegetation is present in the abutment drain that could significantly compromise the performance of the abutment drain.
4.7 Animal burrows or other damage from wildlife		No evidence of animal burrows or other damage caused by wildlife observed. Animal deterrent boxes are filled with poison.	Animal burrows less than 6 inches in depth anywhere on the slope of the embankment without visible signs of seepage, or embankment distress (e.g., cracking slumping, settlement). Animal deterrent boxes are lacking poison.	Animal burrows greater than 6 inches in depth observed anywhere on the slope of the embankment or animal burrows are observed with visible signs of seepage, or embankment distress (e.g., cracking slumping, settlement).

Sand Canyon Dam Safety Inspection Report

5. Dam Crest and Upstream Embankment, Right Side	Assigned Value	1	2	3
5.1 Cracking		No cracks or minor surficial cracks less than ¼" wide that have no observable pattern indicative of slope movement or failure.	Cracking greater than ¼" wide along the embankment crest, or along the alignment of pipes which indicate a new or progressing instability of the embankment.	Cracking greater than ¼" wide that is progressing or changing along the embankment crest, or along the alignment of pipes indicating an active instability of the embankment.
5.2 Vegetation		Liner is free of weeds and trash. No shrubs or trees observed growing in the liner.	Weeds or trash observed on the liner.	Shrubs or trees growing in the liner.
5.3 Animal burrows or other damage from wildlife		No evidence of animal burrows or other damage caused by wildlife observed. Animal deterrent boxes are filled with poison.	Animal burrows less than 6 inches in depth anywhere on the slope of the embankment without visible signs of seepage, or embankment distress (e.g., cracking slumping, settlement). Animal deterrent boxes are lacking poison.	Animal burrows greater than 6 inches in depth observed anywhere on the slope of the embankment or animal burrows are observed with visible signs of seepage, or embankment distress (e.g., cracking slumping, settlement).

Sand Canyon Dam Safety Inspection Report

6. Downstream Embankment, Right Side	Assigned Value	1	2	3
6.1 Seepage		No evidence of damp areas, seepage, or areas which are significantly "greener" or have flourishing vegetation.	Damp areas, seepage, or areas which are significantly "greener" or have flourishing vegetation and clear water indicating no sediment transport through the embankment.	Damp areas, seepage, or areas which are significantly "greener" or have flourishing vegetation and cloudy water indicating sediment transport through the embankment.
6.2 Cracking		No cracks or minor surficial cracks less than 1/4" wide that have no observable pattern indicative of slope movement or failure.	Cracking greater than 1/4" wide along the embankment crest, or along the alignment of pipes which indicate a new or progressing instability of the embankment.	Cracking greater than 1/4" wide that is progressing or changing along the embankment crest, or along the alignment of pipes indicating an active instability of the embankment.
6.3 Settlement, sinkholes, or other depressions (enhanced risk along pipe alignments)		No sinkholes, depressions, or settlement observed.	Dry sinkhole, depression, or vertical settlement 6 inches or less in depth and less than 3 feet in diameter observed.	Dry sinkhole, depression, or vertical settlement greater than 6 inches in depth or greater than 3 feet in diameter observed or any sinkhole, depression, or vertical settlement which has moisture, seepage, or flow present.
6.4 Sliding, sloughing, or bulging (other slope movements)		No evidence of sliding, sloughing, or bulging.	Evidence of sliding, sloughing, or bulging that does not involve the entire downstream slope of the embankment.	Evidence of sliding, sloughing, or bulging which involves the entire slope of the embankment from crest to toe.
6.5 Surface erosion		No erosion observed on the embankment.	Areas of minor erosion observed along downstream slope of the embankment less than 6 inches deep and less than 1 foot wide.	Erosion of the downstream face or the embankment which is greater than 6 inches deep or greater than 1 foot wide or that has the potential to back cut into the crest of the embankment.
6.6 Vegetation		Weeds or grasses are maintained at 6 inches in height or less. No woody vegetation observed. Embankment is free of vegetation such that the face of the embankment is clearly visible from the established inspection routes.	Weeds or grasses are greater than 6 inches in height. Vegetation which impedes up to 25% of the visual inspection of the embankment and limits observation of the embankment from the established inspection routes or woody vegetation is observed.	Vegetation which impedes greater than 25% of the visual inspection of the embankment and limits observation of the embankment from the established inspection routes.
6.7 Animal burrows or other damage from wildlife		No evidence of animal burrows or other damage caused by wildlife observed. Animal deterrent boxes are filled with poison.	Animal burrows less than 6 inches in depth anywhere on the slope of the embankment without visible signs of seepage, or embankment distress (e.g., cracking slumping, settlement). Animal deterrent boxes are lacking poison.	Animal burrows greater than 6 inches in depth observed anywhere on the slope of the embankment or animal burrows are observed with visible signs of seepage, or embankment distress (e.g., cracking slumping, settlement).

Sand Canyon Dam Safety Inspection Report

7. Right Abutment	Assigned Value	1	2	3
7.1 Seepage		No evidence of damp areas, seepage, or areas which are significantly "greener" or have flourishing vegetation.	Damp areas, seepage, or areas which are significantly "greener" or have flourishing vegetation and clear water indicating no sediment transport through the abutment.	Damp areas, seepage, or areas which are significantly "greener" or have flourishing vegetation and cloudy water indicating sediment transport through the abutment.
7.2 Cracking		No cracks or minor surficial cracks less than ¼" wide that have no observable pattern indicative of slope movement or failure.	Cracking greater than ¼" wide along the abutment, which indicate a new or progressing instability of the abutment.	Cracking greater than ¼" wide that is progressing or changing along the abutment.
7.3 Settlement, sinkholes, or other depressions (enhanced risk along pipe alignments)		No sinkholes, depressions, or settlement observed.	Dry sinkhole, depression, or vertical settlement 6 inches or less in depth and less than 3 feet in diameter observed.	Dry sinkhole, depression, or vertical settlement greater than 6 inches in depth or greater than 3 feet in diameter observed or any sinkhole, depression, or vertical settlement which has moisture, seepage, or flow present.
7.4 Sliding, sloughing, or bulging (other slope movements)		No evidence of sliding, sloughing, or bulging.	Evidence of sliding, sloughing, or bulging that is small, shallow, or does not involve the entire slope of the abutment.	Evidence of sliding, sloughing, or bulging which involves the entire slope of the abutment from dam crest to toe.
7.5 Surface erosion		No erosion observed on the abutment.	Areas of minor erosion observed along the abutment less than 6 inches deep and less than 1 foot wide.	Erosion of the abutment which is greater than 6 inches deep or greater than 1 foot wide or that has the potential to back cut into the crest of the embankment.
7.6 Abutment drains		No debris or vegetation observed in the abutment drain.	Debris and vegetation obstructing less than ½ of the capacity in the abutment drain. Debris observed will wash away in an event where half of the capacity of the drain is required.	Significant debris or vegetation is present in the abutment drain that could significantly compromise the performance of the abutment drain.
7.7 Animal burrows or other damage from wildlife		No evidence of animal burrows or other damage caused by wildlife observed. Animal deterrent boxes are filled with poison.	Animal burrows less than 6 inches in depth anywhere on the slope of the embankment without visible signs of seepage, or embankment distress (e.g., cracking slumping, settlement). Animal deterrent boxes are lacking poison.	Animal burrows greater than 6 inches in depth observed anywhere on the slope of the embankment or animal burrows are observed with visible signs of seepage, or embankment distress (e.g., cracking slumping, settlement).

Sand Canyon Dam Safety Inspection Report

8. Toe of Dam, Left Side	Assigned Value	1	2	3
8.1 Seepage, boils, or standing water at or beyond the toe of the embankment		No evidence of seepage, boils, or standing water observed at or beyond the toe of the embankment.	Small, damp areas observed at or beyond the toe of the embankment observed. Areas of seepage around the toe of the embankment during "sunny day" conditions and clear water indicating no sediment transport around the spillway.	Seepage, boils, or standing water at or beyond the toe of the embankment observed. Active seepage observed at the toe of the embankment during "sunny day" conditions and cloudy water indicating sediment transport.
8.2 Cracking		No cracks or minor surficial cracks less than ¼" wide that have no observable pattern indicative of movement along a buried pipe.	Cracking greater than ¼" wide along a buried pipe which indicate a new or progressing instability along the buried pipe.	Cracking greater than ¼" wide that is progressing or changing along the buried pipe indicating an active instability of the embankment.
8.3 Heave or uplift at or beyond the toe of the embankment		No heave or uplift at or beyond the toe of the embankment observed.	Localized areas of heave or uplift that are unlikely to be associated with embankment instability.	Areas of heave or uplift that indicate a potential large-scale instability of the embankment.
8.4 Settlement, sinkholes, or other depressions (enhanced risk along pipe alignments)		No sinkholes, depressions, or settlement observed.	Dry sinkhole, depression, or vertical settlement 6 inches or less in depth and less than 3 feet in diameter observed.	Dry sinkhole, depression, or vertical settlement greater than 6 inches in depth or greater than 3 feet in diameter observed or any sinkhole, depression, or vertical settlement which has moisture, seepage, or flow present.
8.5 Animal burrows or other damage from wildlife		No evidence of animal burrows or other damage caused by wildlife observed. Animal deterrent boxes are filled with poison.	Animal burrows less than 6 inches in depth anywhere on the slope of the embankment without visible signs of seepage, or embankment distress (e.g., cracking slumping, settlement). Animal deterrent boxes are lacking poison.	Animal burrows greater than 6 inches in depth observed anywhere on the slope of the embankment or animal burrows are observed with visible signs of seepage, or embankment distress (e.g., cracking slumping, settlement).
8.6 Visible parts of drainage system		Discharge pipes have no corrosion.	Discharge pipes have minor corrosion, but full function of the system remains.	Discharge pipes have major corrosion and function of the system is impaired.

Sand Canyon Dam Safety Inspection Report

9. Toe of Dam, Right Side	Assigned Value	1	2	3
9.1 Seepage, boils, or standing water at or beyond the toe of the embankment		No evidence of seepage, boils, or standing water observed at or beyond the toe of the embankment.	Small, damp areas observed at or beyond the toe of the embankment observed. Areas of seepage around the toe of the embankment during "sunny day" conditions and clear water indicating no sediment transport around the spillway.	Seepage, boils, or standing water at or beyond the toe of the embankment observed. Active seepage observed at the toe of the embankment during "sunny day" conditions and cloudy water indicating sediment transport.
9.2 Cracking		No cracks or minor surficial cracks less than 1/4" wide that have no observable pattern indicative of movement along a buried pipe.	Cracking greater than 1/4" wide along a buried pipe which indicate a new or progressing instability along the buried pipe.	Cracking greater than 1/4" wide that is progressing or changing along the buried pipe indicating an active instability of the embankment.
9.3 Heave or uplift at or beyond the toe of the embankment		No heave or uplift at or beyond the toe of the embankment observed.	Localized areas of heave or uplift that are unlikely to be associated with embankment instability.	Areas of heave or uplift that indicate a potential large-scale instability of the embankment.
9.4 Settlement, sinkholes, or other depressions (enhanced risk along pipe alignments)		No sinkholes, depressions, or settlement observed.	Dry sinkhole, depression, or vertical settlement 6 inches or less in depth and less than 3 feet in diameter observed.	Dry sinkhole, depression, or vertical settlement greater than 6 inches in depth or greater than 3 feet in diameter observed or any sinkhole, depression, or vertical settlement which has moisture, seepage, or flow present.
9.5 Animal burrows or other damage from wildlife		No evidence of animal burrows or other damage caused by wildlife observed. Animal deterrent boxes are filled with poison.	Animal burrows less than 6 inches in depth anywhere on the slope of the embankment without visible signs of seepage, or embankment distress (e.g., cracking slumping, settlement). Animal deterrent boxes are lacking poison.	Animal burrows greater than 6 inches in depth observed anywhere on the slope of the embankment or animal burrows are observed with visible signs of seepage, or embankment distress (e.g., cracking slumping, settlement).

Sand Canyon Dam Safety Inspection Report

10. Spillway	Assigned Value	1	2	3
10.1 Concrete condition (movement or offsets at joints, cracking, pitting, breakage)		Negligible joint movement, cracking, pitting, breakage, or spalling.	Localized spalling, scaling, or cracking observed.	Widespread spalling, scaling, or cracking present.
10.2 Sidewall drains		No debris or vegetation observed in the sidewall drains.	Debris and vegetation obstructing less than half of the capacity in the sidewall drains. Debris observed will wash away in an event where half of the capacity of the drains is required.	Significant debris or vegetation is present in the sidewall drains that could significantly compromise the performance of the sidewall drains.
10.3 Vegetation		No weeds, shrubs, sediment, or trees observed growing in the liner.	Sediment, trees less than 1/4" in diameter, brush, or other vegetation growing in the liner that may impede the free flow of water.	Shrubs or trees larger than 1/4 "diameter observed growing in the liner.
10.4 Erosion or undermining at concrete weir		No active erosion or scouring around the concrete structures.	Localized areas of erosion or scouring around the concrete structures less than 1 foot deep in any direction.	Widespread erosion or scouring leading to large or long unsupported sections of concrete.
10.5 Condition of inlet at the concrete weir (potential blockages or vegetation)		Inlet is clear of debris that would inhibit flow.	Inlet is blocked by debris, but the blockage is likely to be washed away in a high flow event.	Inlet may become blocked such that flow capacity would be impeded during a high flow event or greater than 25% of the spillway could be blocked by vegetation or other obstructions.
10.6 Condition of spillway approach (potential blockages or vegetation)		Inlet is clear of debris that would inhibit flow.	Inlet is blocked by debris, but the blockage is likely to be washed away in a high flow event.	Inlet may become blocked such that flow capacity would be impeded during a high flow event or greater than 25% of the spillway could be blocked by vegetation or other obstructions. Woody vegetation is observed.
10.7 Erosion or undermining at spillway outlet and energy dissipation structure		No active erosion or scouring around the concrete structures.	Areas of erosion or scouring around the concrete structures less than 1 foot deep in any direction.	Erosion or scouring leading to large or long unsupported sections of concrete.
10.8 Seepage around or underneath spillway slab		No evidence of seepage, damp areas, or boils are observed around the spillway alignment or beneath spillway slabs.	Areas of seepage around the spillway or flow at the toe of the spillway prior to a spill event and during "sunny day" conditions and clear water indicating no sediment transport around the spillway.	Active seepage observed outside of the spillway or at the toe of the spillway prior to a spill event and during "sunny day" conditions and cloudy water indicating sediment transport.

 Spillway channel

 Spillway crest

 Spillway approach

 Energy dissipator



Section 2: Instrumentation Observations and Measurements

Crack measurements, drain and seepage flows, and instrumentation readings are not recorded on this report, they are tracked by IRWD Operations staff using Microsoft Teams and spreadsheets.

Reservoir / Upstream

- | | Yes | No | Unknown | N/A |
|---|--------------------------|--------------------------|--------------------------|--------------------------|
| 1. Crack measurements taken on the liner. | <input type="checkbox"/> | <input type="checkbox"/> | <input type="checkbox"/> | <input type="checkbox"/> |

Drainage Elements and Weirs

- | | | | | |
|---|--------------------------|--------------------------|--------------------------|--------------------------|
| 1. Flow measurements obtained. | <input type="checkbox"/> | <input type="checkbox"/> | <input type="checkbox"/> | <input type="checkbox"/> |
| 2. Measured flow from the drains is within normal and expected range. | <input type="checkbox"/> | <input type="checkbox"/> | <input type="checkbox"/> | <input type="checkbox"/> |
| 3. Seepage water is clear. | <input type="checkbox"/> | <input type="checkbox"/> | <input type="checkbox"/> | <input type="checkbox"/> |

Piezometers and Groundwater Levels

- | | | | | |
|---|--------------------------|--------------------------|--------------------------|--------------------------|
| 1. Piezometer measurement taken. | <input type="checkbox"/> | <input type="checkbox"/> | <input type="checkbox"/> | <input type="checkbox"/> |
| 2. Piezometer results within normal and expected range. | <input type="checkbox"/> | <input type="checkbox"/> | <input type="checkbox"/> | <input type="checkbox"/> |
| 3. Piezometers are in good working condition. | <input type="checkbox"/> | <input type="checkbox"/> | <input type="checkbox"/> | <input type="checkbox"/> |
| 4. Piezometer Spreadsheet was populated. | <input type="checkbox"/> | <input type="checkbox"/> | <input type="checkbox"/> | |

Section 3: Annual or Periodic Inspection

N/A

Inspection Items

- | | Yes | No | Unknown | N/A |
|--|--------------------------|--------------------------|--------------------------|--------------------------|
| 1. Valves are in good working condition and were exercised during the inspection. | <input type="checkbox"/> | <input type="checkbox"/> | <input type="checkbox"/> | <input type="checkbox"/> |
| 2. Drain vaults inspected and in good working condition. | <input type="checkbox"/> | <input type="checkbox"/> | <input type="checkbox"/> | <input type="checkbox"/> |
| 3. Survey completed | <input type="checkbox"/> | <input type="checkbox"/> | <input type="checkbox"/> | <input type="checkbox"/> |
| 4. Drone (UAV) flight completed (3–5-year frequency or as required). | <input type="checkbox"/> | <input type="checkbox"/> | <input type="checkbox"/> | <input type="checkbox"/> |
| 5. Remotely Operated Vehicle (ROV) inspection completed (3–5-year frequency or as required). | <input type="checkbox"/> | <input type="checkbox"/> | <input type="checkbox"/> | <input type="checkbox"/> |
| 6. Emergency outlet valve was exercised and is in good condition. | <input type="checkbox"/> | <input type="checkbox"/> | <input type="checkbox"/> | <input type="checkbox"/> |

If exercised, note the approximate volume discharge: _____

- | | | | | |
|--|--------------------------|--------------------------|--------------------------|--------------------------|
| 7. Aeration system was inspected and is in good condition. | <input type="checkbox"/> | <input type="checkbox"/> | <input type="checkbox"/> | <input type="checkbox"/> |
|--|--------------------------|--------------------------|--------------------------|--------------------------|

Section 4: Event Driven Inspection

N/A

Earthquake

- | | Yes | No | Unknown | N/A |
|---|--------------------------|--------------------------|--------------------------|--------------------------|
| 1. Was the earthquake felt at the site? If so, complete the line below. | <input type="checkbox"/> | <input type="checkbox"/> | <input type="checkbox"/> | <input type="checkbox"/> |

Date: _____ Time: _____ Magnitude: _____ Distance (miles): _____

- | | | | | |
|--|--------------------------|--------------------------|--------------------------|--------------------------|
| 2. Was the epicenter of the earthquake within 75 miles of the dam with a magnitude of 4.0 or greater? | <input type="checkbox"/> | <input type="checkbox"/> | <input type="checkbox"/> | <input type="checkbox"/> |
| 3. Were new cracks, sinkholes, depressions, or new/unusual settlement identified during the inspection? | <input type="checkbox"/> | <input type="checkbox"/> | <input type="checkbox"/> | <input type="checkbox"/> |
| 4. Have existing cracks, sinkholes, depressions, or areas of unusual settlement changed since the last inspection? | <input type="checkbox"/> | <input type="checkbox"/> | <input type="checkbox"/> | <input type="checkbox"/> |

Precipitation

- | | Yes | No | Unknown | N/A |
|---|--------------------------|--------------------------|--------------------------|--------------------------|
| 1. Is water flowing through the spillway? | <input type="checkbox"/> | <input type="checkbox"/> | <input type="checkbox"/> | <input type="checkbox"/> |
| 2. Are flows into and out of the reservoir performing as anticipated and not damaging structures and the dam? | <input type="checkbox"/> | <input type="checkbox"/> | <input type="checkbox"/> | <input type="checkbox"/> |



Section 5: Notes and Comments

Section 6: Items that require further action, attention, or monitoring (assigned values 2 or 3)

Item	Comment	Action	Confirmation # (if applicable)

Section 7: Sign Off

Changed Conditions

	Yes	No	Unknown	N/A
Have any conditions changed since the previous inspection?	<input type="checkbox"/>	<input type="checkbox"/>	<input type="checkbox"/>	<input type="checkbox"/>
Have areas of distress been identified during this inspection?	<input type="checkbox"/>	<input type="checkbox"/>	<input type="checkbox"/>	<input type="checkbox"/>

Water Operations Inspector: _____ Signature: _____ Date: _____

Water Operations Supervisor: _____ Signature: _____ Date: _____

Dam Safety Engineer: _____ Signature: _____ Date: _____

Legend

- A Piezometer
- Outlet Vault
- ◆ Rain Gauge
- Drainage Vault
- Outlet Valves
- Emergency Outlet
- Outlet Pipe
- # Area Number
- Left Abutment
- Right Abutment
- Dam Crest and Upstream
- Embankment, Left Side
- Dam Crest and Upstream
- Embankment, Right Side
- Downstream
- Embankment, Left Side
- Downstream
- Embankment, Right Side
- Toe of Dam, Left Side
- Toe of Dam, Right Side
- Energy Dissipator
- Spillway Approach
- Spillway Channel
- Spillway Crest

Notes
 1. Coordinate System: NAD 1983 StatePlane California VI FIPS 0406 Feet
 2. Data Sources: IRWD, Stantec
 3. Background: NAIP Imagery

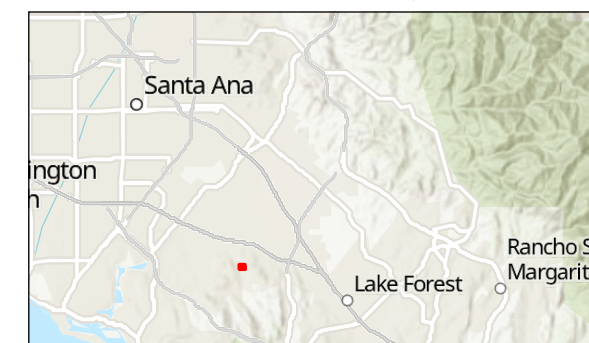
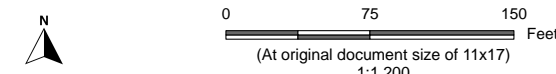

Project Location
 Irvine, CA

Prepared by CS on 2/27/2023
 TR by CB on 2/27/2023
 IR by MD on 2/27/2023

Client/Project
 Irvine Ranch Water District
 Dam Safety Program

Figure No.
1

Title
Sand Canyon Dam Overview



C:\Users\cstege\OneDrive - Stantec\Desktop\IRWD_Export\IRWD_Figures\IRWD_Figures.aprx Dam_Overview Revised: 2023-05-27 By: cstege

Syphon Safety Inspection Report

Inspector(s): _____ Inspection Date: _____

Weather Conditions: _____ Rain Gauge Reading: _____

Reason for Inspection: Routine/Monthly Periodic Event-Driven Photos Taken: NO YES

Additional Comments: _____

Section 1: Visual Observations

1. Reservoir	Assigned Value	1	2	3
1.1 Assessment of the reservoir area and visible watershed.		No signs of erosion, sloughing, or leaned or fallen trees observed in the watershed upstream of the embankment.	Areas of minor erosion, sloughing, or leaned or fallen trees which do not impact the reservoir or storage but could pose a hazard to the reservoir or storage volume in time.	Erosion, sloughing, or landslides within the upstream watershed that have impacted the reservoir or storage volume.
2. Dam Crest and Upstream Embankment, Left Side	Assigned Value	1	2	3
2.1 Cracking		No cracks or minor surficial cracks less than ¼" wide that have no observable pattern indicative of slope movement or failure.	Cracking greater than ¼" wide along the embankment crest, or along the alignment of pipes which may indicate a new or progressing instability of the embankment.	Cracking greater than ¼" wide that is progressing or changing along the embankment crest, or along the alignment of pipes that may indicate an active instability of the embankment.
2.2 Vegetation		Liner is free of weeds and trash. No shrubs or trees observed growing in the liner.	Weeds or trash observed on the liner.	Shrubs or trees growing in the liner.
2.3 Settlement, sinkholes, or other depressions (enhanced risk along pipe alignments)		No sinkholes, depressions, or settlement observed.	Sinkhole, depression, or vertical settlement 6 inches or less in depth and less than 3 feet in diameter observed.	Sinkhole, depression, or vertical settlement greater than 6 inches in depth or greater than 3 feet in diameter observed.
2.4 Animal burrows or other damage from wildlife		No evidence of animal burrows or other damage caused by wildlife observed. Animal deterrent boxes are filled with poison.	Animal burrows less than 6 inches in depth anywhere on the slope of the embankment without visible signs of seepage, or embankment distress (e.g., cracking slumping, settlement). Animal deterrent boxes are lacking poison.	Animal burrows greater than 6 inches in depth observed anywhere on the slope of the embankment or animal burrows are observed with visible signs of seepage, or embankment distress (e.g., cracking slumping, settlement).

Syphon Safety Inspection Report

3. Downstream Embankment, Left Side	Assigned Value	1	2	3
3.1 Seepage		No evidence of damp areas, seepage, or areas which are significantly "greener" or have flourishing vegetation.	Damp areas, seepage, or areas which are significantly "greener" or have flourishing vegetation and clear water indicating no sediment transport through the embankment.	Damp areas, of seepage, or areas which are significantly "greener" or have flourishing vegetation and cloudy water indicating sediment transport through the embankment.
3.2 Cracking		No cracks or minor surficial cracks less than ¼" wide that have no observable pattern indicative of slope movement or failure.	Cracking greater than ¼" wide along the embankment crest, or along the alignment of pipes which indicate a new or progressing instability of the embankment.	Cracking greater than ¼" wide that is progressing or changing along the embankment crest, or along the alignment of pipes indicating an active instability of the embankment.
3.3 Settlement, sinkholes, or other depressions (enhanced risk along pipe alignments)		No sinkholes, depressions, or settlement observed.	Dry sinkhole, depression, or vertical settlement 6 inches or less in depth and less than 3 feet in diameter observed.	Dry sinkhole, depression, or vertical settlement greater than 6 inches in depth or greater than 3 feet in diameter observed or any sinkhole, depression, or vertical settlement which has moisture, seepage, or flow present.
3.4 Sliding, sloughing, or bulging (other slope movements)		No evidence of sliding, sloughing, or bulging.	Evidence of sliding, sloughing, which does not involve the entire downstream slope of the embankment.	Evidence of sliding, sloughing, or bulging which involves the entire slope of the embankment from crest to toe.
3.5 Surface erosion		No erosion observed on the embankment.	Areas of minor erosion observed along downstream slope of the embankment less than 6 inches deep and less than 1 foot wide.	Erosion of the downstream face or the embankment which is greater than 6 inches deep or greater than 1 foot wide or that has the potential to back cut into the crest of the embankment.
3.6 Vegetation		Weeds or grasses are maintained at 6 inches in height or less. No woody vegetation observed. Embankment is free of vegetation such that the face of the embankment is clearly visible from the established inspection routes.	Weeds or grasses are greater than 6 inches in height. Vegetation which impedes up to 25% of the visual inspection of the embankment and limits observation of the embankment from the established inspection routes or woody vegetation is observed.	Vegetation which impedes greater than 25% of the visual inspection of the embankment and limits observation of the embankment from the established inspection routes.
3.7 Animal burrows or other damage from wildlife		No evidence of animal burrows or other damage caused by wildlife observed. Animal deterrent boxes are filled with poison.	Animal burrows less than 6 inches in depth anywhere on the slope of the embankment without visible signs of seepage, or embankment distress (e.g., cracking slumping, settlement). Animal deterrent boxes are lacking poison.	Animal burrows greater than 6 inches in depth observed anywhere on the slope of the embankment or animal burrows are observed with visible signs of seepage, or embankment distress (e.g., cracking slumping, settlement).

Syphon Safety Inspection Report

4. Left Abutment	Assigned Value	1	2	3
4.1 Seepage		No evidence of damp areas, seepage, or areas which are significantly "greener" or have flourishing vegetation.	Damp areas, seepage, or areas which are significantly "greener" or have flourishing vegetation and clear water indicating no sediment transport through the abutment.	Damp areas, seepage, or areas which are significantly "greener" or have flourishing vegetation and cloudy water indicating sediment transport through the abutment.
4.2 Cracking		No cracks or minor surficial cracks less than ¼" wide that have no observable pattern indicative of slope movement or failure.	Cracking greater than ¼" wide along the abutment, which indicate a new or progressing instability of the abutment.	Cracking greater than ¼" wide that is progressing or changing along the abutment.
4.3 Settlement, sinkholes, or other depressions (enhanced risk along pipe alignments)		No sinkholes, depressions, or settlement observed.	Dry sinkhole, depression, or vertical settlement 6 inches or less in depth and less than 3 feet in diameter observed.	Dry sinkhole, depression, or vertical settlement greater than 6 inches in depth or greater than 3 feet in diameter observed or any sinkhole, depression, or vertical settlement which has moisture, seepage, or flow present.
4.4 Sliding, sloughing, or bulging (other slope movements)		No evidence of sliding, sloughing, or bulging.	Evidence of sliding, sloughing, which does not involve the entire slope of the abutment.	Evidence of sliding, sloughing, or bulging which involves the entire slope of the abutment from dam crest to toe.
4.5 Surface erosion		No erosion observed on the abutment.	Areas of minor erosion observed along the abutment less than 6 inches deep and less than 1 foot wide.	Erosion of the abutment which is greater than 6 inches deep or greater than 1 foot wide or that has the potential to back cut into the crest of the embankment.
4.6 Abutment drains		No debris or vegetation observed in the abutment drain.	Debris and vegetation obstructing less than ½ of the capacity in the abutment drain. Debris observed will wash away in an event where half of the capacity of the drain is required.	Significant debris or vegetation is present in the abutment drain that could significantly compromise the performance of the abutment drain.
4.7 Animal burrows or other damage from wildlife		No evidence of animal burrows or other damage caused by wildlife observed. Animal deterrent boxes are filled with poison.	Animal burrows less than 6 inches in depth anywhere on the slope of the embankment without visible signs of seepage, or embankment distress (e.g., cracking slumping, settlement). Animal deterrent boxes are lacking poison.	Animal burrows greater than 6 inches in depth observed anywhere on the slope of the embankment or animal burrows are observed with visible signs of seepage, or embankment distress (e.g., cracking slumping, settlement).
4.8 Access road		Road surface is even with no rutting, wash boarding, or erosion.	Areas of minor rutting, wash boarding, or erosion but vehicle access is not impaired.	Areas of rutting, wash boarding, or erosion which limits vehicle access to the dam.

Syphon Safety Inspection Report

5. Dam Crest and Upstream Embankment, Right Side	Assigned Value	1	2	3
5.1 Cracking		No cracks or minor surficial cracks less than ¼" wide that have no observable pattern indicative of slope movement or failure.	Cracking greater than ¼" wide along the embankment crest, or along the alignment of pipes which indicate a new or progressing instability of the embankment.	Cracking greater than ¼" wide that is progressing or changing along the embankment crest, or along the alignment of pipes indicating an active instability of the embankment.
5.2 Vegetation		Liner is free of weeds and trash. No shrubs or trees observed growing in the liner.	Weeds or trash observed on the liner.	Shrubs or trees growing in the liner.
5.3 Animal burrows or other damage from wildlife		No evidence of animal burrows or other damage caused by wildlife observed. Animal deterrent boxes are filled with poison.	Animal burrows less than 6 inches in depth anywhere on the slope of the embankment without visible signs of seepage, or embankment distress (e.g., cracking slumping, settlement). Animal deterrent boxes are lacking poison.	Animal burrows greater than 6 inches in depth observed anywhere on the slope of the embankment or animal burrows are observed with visible signs of seepage, or embankment distress (e.g., cracking slumping, settlement).

Syphon Safety Inspection Report

6. Downstream Embankment, Right Side	Assigned Value	1	2	3
6.1 Seepage		No evidence of damp areas, seepage, or areas which are significantly "greener" or have flourishing vegetation.	Damp areas, seepage, or areas which are significantly "greener" or have flourishing vegetation and clear water indicating no sediment transport through the embankment.	Damp areas, seepage, or areas which are significantly "greener" or have flourishing vegetation and cloudy water indicating sediment transport through the embankment.
6.2 Cracking		No cracks or minor surficial cracks less than ¼" wide that have no observable pattern indicative of slope movement or failure.	Cracking greater than ¼" wide along the embankment crest, or along the alignment of pipes which indicate a new or progressing instability of the embankment.	Cracking greater than ¼" wide that is progressing or changing along the embankment crest, or along the alignment of pipes indicating an active instability of the embankment.
6.3 Settlement, sinkholes, or other depressions (enhanced risk along pipe alignments)		No sinkholes, depressions, or settlement observed.	Dry sinkhole, depression, or vertical settlement 6 inches or less in depth and less than 3 feet in diameter observed.	Dry sinkhole, depression, or vertical settlement greater than 6 inches in depth or greater than 3 feet in diameter observed or any sinkhole, depression, or vertical settlement which has moisture, seepage, or flow present.
6.4 Sliding, sloughing, or bulging (other slope movements)		No evidence of sliding, sloughing, or bulging.	Evidence of sliding, sloughing, which does not involve the entire downstream slope of the embankment.	Evidence of sliding, sloughing, or bulging which involves the entire slope of the embankment from crest to toe.
6.5 Surface erosion		No erosion observed on the embankment.	Areas of minor erosion observed along downstream slope of the embankment less than 6 inches deep and less than 1 foot wide.	Erosion of the downstream face or the embankment which is greater than 6 inches deep or greater than 1 foot wide or that has the potential to back cut into the crest of the embankment.
6.6 Vegetation		Weeds or grasses are maintained at 6 inches in height or less. No woody vegetation observed. Embankment is free of vegetation such that the face of the embankment is clearly visible from the established inspection routes.	Weeds or grasses are greater than 6 inches in height. Vegetation which impedes up to 25% of the visual inspection of the embankment and limits observation of the embankment from the established inspection routes or woody vegetation is observed.	Vegetation which impedes greater than 25% of the visual inspection of the embankment and limits observation of the embankment from the established inspection routes.
6.7 Animal burrows or other damage from wildlife		No evidence of animal burrows or other damage caused by wildlife observed. Animal deterrent boxes are filled with poison.	Animal burrows less than 6 inches in depth anywhere on the slope of the embankment without visible signs of seepage, or embankment distress (e.g., cracking slumping, settlement). Animal deterrent boxes are lacking poison.	Animal burrows greater than 6 inches in depth observed anywhere on the slope of the embankment or animal burrows are observed with visible signs of seepage, or embankment distress (e.g., cracking slumping, settlement).

Syphon Safety Inspection Report

7. Right Abutment	Assigned Value	1	2	3
7.1 Seepage		No evidence of damp areas, seepage, or areas which are significantly "greener" or have flourishing vegetation.	Damp areas, seepage, or areas which are significantly "greener" or have flourishing vegetation and clear water indicating no sediment transport through the abutment.	Damp areas, seepage, or areas which are significantly "greener" or have flourishing vegetation and cloudy water indicating sediment transport through the abutment.
7.2 Cracking		No cracks or minor surficial cracks less than ¼" wide that have no observable pattern indicative of slope movement or failure.	Cracking greater than ¼" wide along the abutment, which indicate a new or progressing instability of the abutment.	Cracking greater than ¼" wide that is progressing or changing along the abutment.
7.3 Settlement, sinkholes, or other depressions (enhanced risk along pipe alignments)		No sinkholes, depressions, or settlement observed.	Dry sinkhole, depression, or vertical settlement 6 inches or less in depth and less than 3 feet in diameter observed.	Dry sinkhole, depression, or vertical settlement greater than 6 inches in depth or greater than 3 feet in diameter observed or any sinkhole, depression, or vertical settlement which has moisture, seepage, or flow present.
7.4 Sliding, sloughing, or bulging (other slope movements)		No evidence of sliding, sloughing, or bulging.	Evidence of sliding, sloughing, or bulging that is small, shallow, or does not involve the entire slope of the abutment.	Evidence of sliding, sloughing, or bulging which involves the entire slope of the abutment from dam crest to toe.
7.5 Surface erosion		No erosion observed on the abutment.	Areas of minor erosion observed along the abutment less than 6 inches deep and less than 1 foot wide.	Erosion of the abutment which is greater than 6 inches deep or greater than 1 foot wide or that has the potential to back cut into the crest of the embankment.
7.6 Abutment drains		No debris or vegetation observed in the abutment drain.	Debris and vegetation obstructing less than ½ of the capacity in the abutment drain. Debris observed will wash away in an event where half of the capacity of the drain is required.	Significant debris or vegetation is present in the abutment drain that could significantly compromise the performance of the abutment drain.
7.7 Animal burrows or other damage from wildlife		No evidence of animal burrows or other damage caused by wildlife observed. Animal deterrent boxes are filled with poison.	Animal burrows less than 6 inches in depth anywhere on the slope of the embankment without visible signs of seepage, or embankment distress (e.g., cracking slumping, settlement). Animal deterrent boxes are lacking poison.	Animal burrows greater than 6 inches in depth observed anywhere on the slope of the embankment or animal burrows are observed with visible signs of seepage, or embankment distress (e.g., cracking slumping, settlement).
7.8 Access road		Road surface is even with no rutting, wash boarding, or erosion.	Areas of minor rutting, wash boarding, or erosion but vehicle access is not impaired.	Areas of rutting, wash boarding, or erosion which limits vehicle access to the dam.

Syphon Safety Inspection Report

8. Toe of Dam, Left Side	Assigned Value	1	2	3
8.1 Seepage, boils, or standing water at or beyond the toe of the embankment		No evidence of seepage, boils, or standing water observed at or beyond the toe of the embankment.	Small, damp areas observed at or beyond the toe of the embankment observed. Areas of seepage around the toe of the embankment during "sunny day" conditions and clear water indicating no sediment transport around the spillway.	Seepage, boils, or standing water at or beyond the toe of the embankment observed. Active seepage observed at the toe of the embankment during "sunny day" conditions and cloudy water indicating sediment transport.
8.2 Cracking		No cracks or minor surficial cracks less than 1/4" wide that have no observable pattern indicative of movement along a buried pipe.	Cracking greater than 1/4" wide along a buried pipe which indicate a new or progressing instability along the buried pipe.	Cracking greater than 1/4" wide that is progressing or changing along the buried pipe indicating an active instability of the embankment.
8.3 Heave or uplift at or beyond the toe of the embankment		No heave or uplift at or beyond the toe of the embankment observed.	Localized areas of heave or uplift that are unlikely to be associated with embankment instability.	Areas of heave or uplift that indicate a potential large-scale instability of the embankment.
8.4 Settlement, sinkholes, or other depressions (enhanced risk along pipe alignments)		No sinkholes, depressions, or settlement observed.	Dry sinkhole, depression, or vertical settlement 6 inches or less in depth and less than 3 feet in diameter observed.	Dry sinkhole, depression, or vertical settlement greater than 6 inches in depth or greater than 3 feet in diameter observed or any sinkhole, depression, or vertical settlement which has moisture, seepage, or flow present.
8.5 Animal burrows or other damage from wildlife		No evidence of animal burrows or other damage caused by wildlife observed. Animal deterrent boxes are filled with poison.	Animal burrows less than 6 inches in depth anywhere on the slope of the embankment without visible signs of seepage, or embankment distress (e.g., cracking slumping, settlement). Animal deterrent boxes are lacking poison.	Animal burrows greater than 6 inches in depth observed anywhere on the slope of the embankment or animal burrows are observed with visible signs of seepage, or embankment distress (e.g., cracking slumping, settlement).
8.6 Visible parts of drainage system		Discharge pipes have no corrosion and paint is intact, only minor touch ups required.	Discharge pipes have minor corrosion, but full function of the system remains.	Discharge pipes have major corrosion and function of the system is impaired.

Syphon Safety Inspection Report

9. Toe of Dam, Right Side	Assigned Value	1	2	3
9.1 Seepage, boils, or standing water at or beyond the toe of the embankment		No evidence of seepage, boils, or standing water observed at or beyond the toe of the embankment.	Small, damp areas observed at or beyond the toe of the embankment observed. Areas of seepage around the toe of the embankment during "sunny day" conditions and clear water indicating no sediment transport around the spillway.	Seepage, boils, or standing water at or beyond the toe of the embankment observed. Active seepage observed at the toe of the embankment during "sunny day" conditions and cloudy water indicating sediment transport.
9.2 Cracking		No cracks or minor surficial cracks less than ¼" wide that have no observable pattern indicative of movement along a buried pipe.	Cracking greater than ¼" wide along a buried pipe which indicate a new or progressing instability along the buried pipe.	Cracking greater than ¼" wide that is progressing or changing along the buried pipe indicating an active instability of the embankment.
9.3 Heave or uplift at or beyond the toe of the embankment		No heave or uplift at or beyond the toe of the embankment observed.	Localized areas of heave or uplift that are unlikely to be associated with embankment instability.	Areas of heave or uplift that indicate a potential large-scale instability of the embankment.
9.4 Settlement, sinkholes, or other depressions (enhanced risk along pipe alignments)		No sinkholes, depressions, or settlement observed.	Dry sinkhole, depression, or vertical settlement 6 inches or less in depth and less than 3 feet in diameter observed.	Dry sinkhole, depression, or vertical settlement greater than 6 inches in depth or greater than 3 feet in diameter observed or any sinkhole, depression, or vertical settlement which has moisture, seepage, or flow present.
9.5 Animal burrows or other damage from wildlife		No evidence of animal burrows or other damage caused by wildlife observed. Animal deterrent boxes are filled with poison.	Animal burrows less than 6 inches in depth anywhere on the slope of the embankment without visible signs of seepage, or embankment distress (e.g., cracking slumping, settlement). Animal deterrent boxes are lacking poison.	Animal burrows greater than 6 inches in depth observed anywhere on the slope of the embankment or animal burrows are observed with visible signs of seepage, or embankment distress (e.g., cracking slumping, settlement).
9.6 Visible parts of drainage system		Discharge pipes have no corrosion and paint is intact, only minor touch ups required.	Discharge pipes have minor corrosion, but full function of the system remains.	Discharge pipes have major corrosion and function of the system is impaired.

Syphon Safety Inspection Report

10. Spillway	Assigned Value	1	2	3
10.1 Condition of inlet (potential blockages or vegetation)		Inlet is clear of debris that would inhibit flow.	Inlet is blocked by debris, but the blockage is likely to be washed away in a high flow event.	Inlet may become blocked such that flow capacity would be impeded during a high flow event or greater than 25% of the spillway could be blocked by vegetation or other obstructions.
10.2 Condition of channel (potential blockages or vegetation)		Channel is clear of debris that would inhibit flow.	Channel is blocked by debris, but the blockage is likely to be washed away in a high flow event.	Channel may become blocked such that flow capacity would be impeded during a high flow event or greater than 25% of the spillway could be blocked by vegetation or other obstructions.
10.3 Animal burrows or other damage from wildlife		No evidence of animal burrows or other damage caused by wildlife observed. Animal deterrent boxes are filled with poison.	Animal burrows less than 6 inches in depth anywhere on the slope of the embankment without visible signs of seepage, or embankment distress (e.g., cracking slumping, settlement). Animal deterrent boxes are lacking poison.	Animal burrows greater than 6 inches in depth observed anywhere on the slope of the embankment or animal burrows are observed with visible signs of seepage, or embankment distress (e.g., cracking slumping, settlement).
10.4 Condition of spillway outlet (potential blockages or vegetation)		Outlet is clear of debris that would inhibit flow.	Outlet is blocked by debris, but the blockage is likely to be washed away in a high flow event.	Outlet may become blocked such that flow capacity would be impeded during a high flow event or greater than 25% of the spillway could be blocked by vegetation or other obstructions. Woody vegetation is observed.



Section 2: Instrumentation Observations and Measurements

Crack measurements, drain and seepage flows, and instrumentation readings are not recorded on this report, they are tracked by IRWD Operations staff using Microsoft Teams and spreadsheets.

Reservoir / Upstream

- | | Yes | No | Unknown | N/A |
|---|--------------------------|--------------------------|--------------------------|--------------------------|
| 1. Crack measurements taken on the liner. | <input type="checkbox"/> | <input type="checkbox"/> | <input type="checkbox"/> | <input type="checkbox"/> |

Drainage Elements and Weirs

- | | | | | |
|---|--------------------------|--------------------------|--------------------------|--------------------------|
| 1. Flow measurements obtained. | <input type="checkbox"/> | <input type="checkbox"/> | <input type="checkbox"/> | <input type="checkbox"/> |
| 2. Measured flow from the drains is within normal and expected range. | <input type="checkbox"/> | <input type="checkbox"/> | <input type="checkbox"/> | <input type="checkbox"/> |
| 3. Seepage water is clear. | <input type="checkbox"/> | <input type="checkbox"/> | <input type="checkbox"/> | <input type="checkbox"/> |

Piezometers and Groundwater Levels

- | | | | | |
|---|--------------------------|--------------------------|--------------------------|--------------------------|
| 1. Piezometer measurement taken. | <input type="checkbox"/> | <input type="checkbox"/> | <input type="checkbox"/> | <input type="checkbox"/> |
| 2. Piezometer results within normal and expected range. | <input type="checkbox"/> | <input type="checkbox"/> | <input type="checkbox"/> | <input type="checkbox"/> |
| 3. Piezometers are in good working condition. | <input type="checkbox"/> | <input type="checkbox"/> | <input type="checkbox"/> | <input type="checkbox"/> |
| 4. Piezometer spreadsheet was populated. | <input type="checkbox"/> | <input type="checkbox"/> | <input type="checkbox"/> | <input type="checkbox"/> |

Section 3: Annual or Periodic Inspection

N/A

Inspection Items

- | | Yes | No | Unknown | N/A |
|--|--------------------------|--------------------------|--------------------------|--------------------------|
| 1. Valves are in good working condition and were exercised during the inspection. | <input type="checkbox"/> | <input type="checkbox"/> | <input type="checkbox"/> | <input type="checkbox"/> |
| 2. Drain vaults inspected and in good working condition. | <input type="checkbox"/> | <input type="checkbox"/> | <input type="checkbox"/> | <input type="checkbox"/> |
| 3. Survey completed | <input type="checkbox"/> | <input type="checkbox"/> | <input type="checkbox"/> | <input type="checkbox"/> |
| 4. Drone (UAV) flight completed (3–5-year frequency or as required). | <input type="checkbox"/> | <input type="checkbox"/> | <input type="checkbox"/> | <input type="checkbox"/> |
| 5. Remotely Operated Vehicle (ROV) inspection completed (3–5-year frequency or as required). | <input type="checkbox"/> | <input type="checkbox"/> | <input type="checkbox"/> | <input type="checkbox"/> |
| 6. Emergency outlet valve was exercised and is in good condition. | <input type="checkbox"/> | <input type="checkbox"/> | <input type="checkbox"/> | <input type="checkbox"/> |

If exercised, note the approximate volume discharge: _____

- | | | | | |
|--|--------------------------|--------------------------|--------------------------|--------------------------|
| 7. Aeration system was inspected and is in good condition. | <input type="checkbox"/> | <input type="checkbox"/> | <input type="checkbox"/> | <input type="checkbox"/> |
|--|--------------------------|--------------------------|--------------------------|--------------------------|

Section 4: Event Driven Inspection

N/A

Event driven inspections include observations following earthquake or storm events. These inspections are performed based on the event thresholds established by IRWD.

Earthquake

- | | Yes | No | Unknown | N/A |
|---|--------------------------|--------------------------|--------------------------|--------------------------|
| 1. Was the earthquake felt at the site? If so, complete the line below. | <input type="checkbox"/> | <input type="checkbox"/> | <input type="checkbox"/> | <input type="checkbox"/> |

Date: _____ Time: _____ Magnitude: _____ Distance (miles): _____

- | | | | | |
|--|--------------------------|--------------------------|--------------------------|--------------------------|
| 2. Was the epicenter of the earthquake within 75 miles of the dam with a magnitude of 4.0 or greater? | <input type="checkbox"/> | <input type="checkbox"/> | <input type="checkbox"/> | <input type="checkbox"/> |
| 3. Were new cracks, sinkholes, depressions, or new/unusual settlement identified during the inspection? | <input type="checkbox"/> | <input type="checkbox"/> | <input type="checkbox"/> | <input type="checkbox"/> |
| 4. Have existing cracks, sinkholes, depressions, or areas of unusual settlement changed since the last inspection? | <input type="checkbox"/> | <input type="checkbox"/> | <input type="checkbox"/> | <input type="checkbox"/> |

Precipitation

- | | Yes | No | Unknown | N/A |
|---|--------------------------|--------------------------|--------------------------|--------------------------|
| 1. Is water flowing through the spillway? | <input type="checkbox"/> | <input type="checkbox"/> | <input type="checkbox"/> | <input type="checkbox"/> |
| 2. Are flows into and out of the reservoir performing as anticipated and not damaging structures and the dam? | <input type="checkbox"/> | <input type="checkbox"/> | <input type="checkbox"/> | <input type="checkbox"/> |



Section 5: Notes and Comments

Section 6: Items that require further action, attention, or monitoring (assigned values 2 or 3)

Item	Comment	Action	Confirmation # (if applicable)

Section 7: Sign Off

Changed Conditions

	Yes	No	Unknown	N/A
Have any conditions changed since the previous inspection?	<input type="checkbox"/>	<input type="checkbox"/>	<input type="checkbox"/>	<input type="checkbox"/>
Have areas of distress been identified during this inspection?	<input type="checkbox"/>	<input type="checkbox"/>	<input type="checkbox"/>	<input type="checkbox"/>

Water Operations Inspector: _____ Signature: _____ Date: _____

Water Operations Supervisor: _____ Signature: _____ Date: _____

Dam Safety Engineer: _____ Signature: _____ Date: _____

Legend

- A Piezometer
- ◆ Rain Gauge
- Drainage Vault
- Outlet Pipe
- # Area Number
- Left Abutment
- Right Abutment
- Dam Crest and Upstream
- Embankment, Left Side
- Dam Crest and Upstream Embankment, Right Side
- Downstream Embankment, Left Side
- Downstream Embankment, Right Side
- Toe of Dam, Left Side
- Toe of Dam, Right Side
- Spillway Channel



Notes
 1. Coordinate System: NAD 1983 StatePlane California VI FIPS 0406 Feet
 2. Data Sources: IRWD, Stantec
 3. Background: NAIP Imagery

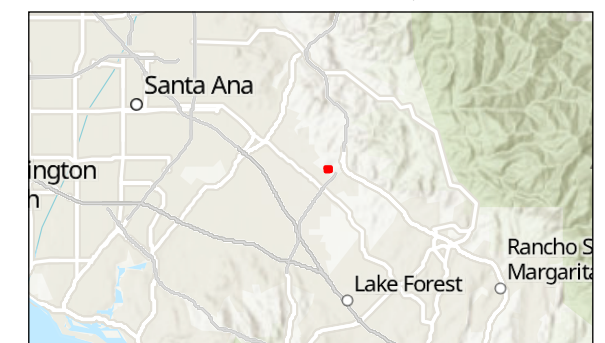
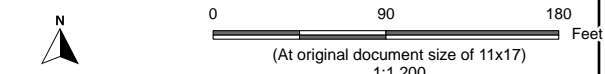

Project Location
 Irvine, CA

Prepared by CS on 2/24/2023
 TR by CB on 2/24/2023
 IR by MD on 2/24/2023

Client/Project
 Irvine Ranch Water District
 Dam Safety Program

Figure No.
 1

Title
 Syphon Dam Overview

C:\Users\cstege\OneDrive - Stantec\Desktop\IRWD_Export\IRWD_Figures\IRWD_Figures.aprx Dam_Overview Revised: 2023-02-24 By: cstege

Rattlesnake Canyon Dam Safety Inspection Report

Inspector(s): _____ Inspection Date: _____

Weather Conditions: _____ Rain Gauge Reading: _____

Reason for Inspection: Routine/Monthly Periodic Event-Driven Photos Taken: NO YES

Additional Comments: _____

Section 1: Visual Observations

1. Reservoir	Assigned Value	1	2	3
1.1 Assessment of the reservoir area and visible watershed.		No signs of erosion, sloughing, or leaned or fallen trees observed in the watershed upstream of the embankment.	Areas of minor erosion, sloughing, or leaned or fallen trees which do not impact the reservoir or storage but could pose a hazard to the reservoir or storage volume in time.	Erosion, sloughing, or landslides within the upstream watershed that have impacted the reservoir or storage volume.
2. Dam Crest and Upstream Embankment, Left Side	Assigned Value	1	2	3
2.1 Cracking		No cracks or minor surficial cracks less than ¼" wide that have no observable pattern indicative of slope movement or failure.	Cracking greater than ¼" wide along the embankment crest, or along the alignment of pipes which may indicate a new or progressing instability of the embankment.	Cracking greater than ¼" wide that is progressing or changing along the embankment crest, or along the alignment of pipes that may indicate an active instability of the embankment.
2.2 Vegetation		Liner is free of weeds and trash. No shrubs or trees observed growing in the liner.	Weeds or trash observed on the liner.	Shrubs or trees growing in the liner.
2.3 Settlement, sinkholes, or other depressions (enhanced risk along pipe alignments)		No sinkholes, depressions, or settlement observed.	Sinkhole, depression, or vertical settlement 6 inches or less in depth and less than 3 feet in diameter observed.	Sinkhole, depression, or vertical settlement greater than 6 inches in depth or greater than 3 feet in diameter observed.
2.4 Animal burrows or other damage from wildlife		No evidence of animal burrows or other damage caused by wildlife observed. Animal deterrent boxes are filled with poison.	Animal burrows less than 6 inches in depth anywhere on the slope of the embankment without visible signs of seepage, or embankment distress (e.g., cracking slumping, settlement). Animal deterrent boxes are lacking poison.	Animal burrows greater than 6 inches in depth observed anywhere on the slope of the embankment or animal burrows are observed with visible signs of seepage, or embankment distress (e.g., cracking slumping, settlement).

Rattlesnake Canyon Dam Safety Inspection Report

3. Downstream Embankment, Left Side	Assigned Value	1	2	3
3.1 Seepage		No evidence of damp areas, seepage, or areas which are significantly "greener" or have flourishing vegetation.	Damp areas, seepage, or areas which are significantly "greener" or have flourishing vegetation and clear water indicating no sediment transport through the embankment.	Damp areas, of seepage, or areas which are significantly "greener" or have flourishing vegetation and cloudy water indicating sediment transport through the embankment.
3.2 Cracking		No cracks or minor surficial cracks less than 1/4" wide that have no observable pattern indicative of slope movement or failure.	Cracking greater than 1/4" wide along the embankment crest, or along the alignment of pipes which indicate a new or progressing instability of the embankment.	Cracking greater than 1/4" wide that is progressing or changing along the embankment crest, or along the alignment of pipes indicating an active instability of the embankment.
3.3 Settlement, sinkholes, or other depressions (enhanced risk along pipe alignments)		No sinkholes, depressions, or settlement observed.	Dry sinkhole, depression, or vertical settlement 6 inches or less in depth and less than 3 feet in diameter observed.	Dry sinkhole, depression, or vertical settlement greater than 6 inches in depth or greater than 3 feet in diameter observed or any sinkhole, depression, or vertical settlement which has moisture, seepage, or flow present.
3.4 Sliding, sloughing, or bulging (other slope movements)		No evidence of sliding, sloughing, or bulging.	Evidence of sliding, sloughing, or bulging that does not involve the entire downstream slope of the embankment.	Evidence of sliding, sloughing, or bulging which involves the entire slope of the embankment from crest to toe.
3.5 Surface erosion		No erosion observed on the embankment.	Areas of minor erosion observed along downstream slope of the embankment less than 6 inches deep and less than 1 foot wide.	Erosion of the downstream face or the embankment which is greater than 6 inches deep or greater than 1 foot wide or that has the potential to back cut into the crest of the embankment.
3.6 Vegetation		Weeds or grasses are maintained at 6 inches in height or less. No woody vegetation observed. Embankment is free of vegetation such that the face of the embankment is clearly visible from the established inspection routes.	Weeds or grasses are greater than 6 inches in height. Vegetation which impedes up to 25% of the visual inspection of the embankment and limits observation of the embankment from the established inspection routes or woody vegetation is observed.	Vegetation which impedes greater than 25% of the visual inspection of the embankment and limits observation of the embankment from the established inspection routes.
3.7 Animal burrows or other damage from wildlife		No evidence of animal burrows or other damage caused by wildlife observed. Animal deterrent boxes are filled with poison.	Animal burrows less than 6 inches in depth anywhere on the slope of the embankment without visible signs of seepage, or embankment distress (e.g., cracking slumping, settlement). Animal deterrent boxes are lacking poison.	Animal burrows greater than 6 inches in depth observed anywhere on the slope of the embankment or animal burrows are observed with visible signs of seepage, or embankment distress (e.g., cracking slumping, settlement).

Rattlesnake Canyon Dam Safety Inspection Report

4. Left Abutment	Assigned Value	1	2	3
4.1 Seepage		No evidence of damp areas, seepage, or areas which are significantly "greener" or have flourishing vegetation.	Damp areas, seepage, or areas which are significantly "greener" or have flourishing vegetation and clear water indicating no sediment transport through the abutment.	Damp areas, seepage, or areas which are significantly "greener" or have flourishing vegetation and cloudy water indicating sediment transport through the abutment.
4.2 Cracking		No cracks or minor surficial cracks less than ¼" wide that have no observable pattern indicative of slope movement or failure.	Cracking greater than ¼" wide along the abutment, which indicate a new or progressing instability of the abutment.	Cracking greater than ¼" wide that is progressing or changing along the abutment.
4.3 Settlement, sinkholes, or other depressions (enhanced risk along pipe alignments)		No sinkholes, depressions, or settlement observed.	Dry sinkhole, depression, or vertical settlement 6 inches or less in depth and less than 3 feet in diameter observed.	Dry sinkhole, depression, or vertical settlement greater than 6 inches in depth or greater than 3 feet in diameter observed or any sinkhole, depression, or vertical settlement which has moisture, seepage, or flow present.
4.4 Sliding, sloughing, or bulging (other slope movements)		No evidence of sliding, sloughing, or bulging.	Evidence of sliding, sloughing, or bulging that does not involve the entire downstream slope of the abutment.	Evidence of sliding, sloughing, or bulging which involves the entire slope of the abutment from dam crest to toe.
4.5 Surface erosion		No erosion observed on the abutment.	Areas of minor erosion observed along the abutment less than 6 inches deep and less than 1 foot wide.	Erosion of the abutment which is greater than 6 inches deep or greater than 1 foot wide or that has the potential to back cut into the crest of the embankment.
4.6 Animal burrows or other damage from wildlife		No evidence of animal burrows or other damage caused by wildlife observed. Animal deterrent boxes are filled with poison.	Animal burrows less than 6 inches in depth anywhere on the slope of the embankment without visible signs of seepage, or embankment distress (e.g., cracking slumping, settlement). Animal deterrent boxes are lacking poison.	Animal burrows greater than 6 inches in depth observed anywhere on the slope of the embankment or animal burrows are observed with visible signs of seepage, or embankment distress (e.g., cracking slumping, settlement).
4.7 Access road		Road surface is even with no rutting, wash boarding, or erosion.	Areas of minor rutting, wash boarding, or erosion but vehicle access is not impaired.	Areas of rutting, wash boarding, or erosion which limits vehicle access to the dam.

Rattlesnake Canyon Dam Safety Inspection Report

5. Dam Crest and Upstream Embankment, Right Side	Assigned Value	1	2	3
5.1 Cracking		No cracks or minor surficial cracks less than ¼" wide that have no observable pattern indicative of slope movement or failure.	Cracking greater than ¼" wide along the embankment crest, or along the alignment of pipes which indicate a new or progressing instability of the embankment.	Cracking greater than ¼" wide that is progressing or changing along the embankment crest, or along the alignment of pipes indicating an active instability of the embankment.
5.2 Vegetation		Liner is free of weeds and trash. No shrubs or trees observed growing in the liner.	Weeds or trash observed on the liner.	Shrubs or trees growing in the liner.
5.3 Animal burrows or other damage from wildlife		No evidence of animal burrows or other damage caused by wildlife observed. Animal deterrent boxes are filled with poison.	Animal burrows less than 6 inches in depth anywhere on the slope of the embankment without visible signs of seepage, or embankment distress (e.g., cracking slumping, settlement). Animal deterrent boxes are lacking poison.	Animal burrows greater than 6 inches in depth observed anywhere on the slope of the embankment or animal burrows are observed with visible signs of seepage, or embankment distress (e.g., cracking slumping, settlement).

Rattlesnake Canyon Dam Safety Inspection Report

6. Downstream Embankment, Right Side	Assigned Value	1	2	3
6.1 Seepage		No evidence of damp areas, seepage, or areas which are significantly "greener" or have flourishing vegetation.	Damp areas, seepage, or areas which are significantly "greener" or have flourishing vegetation and clear water indicating no sediment transport through the embankment.	Damp areas, seepage, or areas which are significantly "greener" or have flourishing vegetation and cloudy water indicating sediment transport through the embankment.
6.2 Cracking		No cracks or minor surficial cracks less than ¼" wide that have no observable pattern indicative of slope movement or failure.	Cracking greater than ¼" wide along the embankment crest, or along the alignment of pipes which indicate a new or progressing instability of the embankment.	Cracking greater than ¼" wide that is progressing or changing along the embankment crest, or along the alignment of pipes indicating an active instability of the embankment.
6.3 Settlement, sinkholes, or other depressions (enhanced risk along pipe alignments)		No sinkholes, depressions, or settlement observed.	Dry sinkhole, depression, or vertical settlement 6 inches or less in depth and less than 3 feet in diameter observed.	Dry sinkhole, depression, or vertical settlement greater than 6 inches in depth or greater than 3 feet in diameter observed or any sinkhole, depression, or vertical settlement which has moisture, seepage, or flow present.
6.4 Sliding, sloughing, or bulging (other slope movements)		No evidence of sliding, sloughing, or bulging.	Evidence of sliding, sloughing, or bulging that does not involve the entire downstream slope of the embankment.	Evidence of sliding, sloughing, or bulging which involves the entire slope of the embankment from crest to toe.
6.5 Surface erosion		No erosion observed on the embankment.	Areas of minor erosion observed along downstream slope of the embankment less than 6 inches deep and less than 1 foot wide.	Erosion of the downstream face or the embankment which is greater than 6 inches deep or greater than 1 foot wide or that has the potential to back cut into the crest of the embankment.
6.6 Vegetation		Weeds or grasses are maintained at 6 inches in height or less. No woody vegetation observed. Embankment is free of vegetation such that the face of the embankment is clearly visible from the established inspection routes.	Weeds or grasses are greater than 6 inches in height. Vegetation which impedes up to 25% of the visual inspection of the embankment and limits observation of the embankment from the established inspection routes or woody vegetation is observed.	Vegetation which impedes greater than 25% of the visual inspection of the embankment and limits observation of the embankment from the established inspection routes.
6.7 Animal burrows or other damage from wildlife		No evidence of animal burrows or other damage caused by wildlife observed. Animal deterrent boxes are filled with poison.	Animal burrows less than 6 inches in depth anywhere on the slope of the embankment without visible signs of seepage, or embankment distress (e.g., cracking slumping, settlement). Animal deterrent boxes are lacking poison.	Animal burrows greater than 6 inches in depth observed anywhere on the slope of the embankment or animal burrows are observed with visible signs of seepage, or embankment distress (e.g., cracking slumping, settlement).

Rattlesnake Canyon Dam Safety Inspection Report

7. Right Abutment	Assigned Value	1	2	3
7.1 Seepage		No evidence of damp areas, seepage, or areas which are significantly "greener" or have flourishing vegetation.	Damp areas, seepage, or areas which are significantly "greener" or have flourishing vegetation and clear water indicating no sediment transport through the abutment.	Damp areas, seepage, or areas which are significantly "greener" or have flourishing vegetation and cloudy water indicating sediment transport through the abutment.
7.2 Cracking		No cracks or minor surficial cracks less than ¼" wide that have no observable pattern indicative of slope movement or failure.	Cracking greater than ¼" wide along the abutment, which indicate a new or progressing instability of the abutment.	Cracking greater than ¼" wide that is progressing or changing along the abutment.
7.3 Settlement, sinkholes, or other depressions (enhanced risk along pipe alignments)		No sinkholes, depressions, or settlement observed.	Dry sinkhole, depression, or vertical settlement 6 inches or less in depth and less than 3 feet in diameter observed.	Dry sinkhole, depression, or vertical settlement greater than 6 inches in depth or greater than 3 feet in diameter observed or any sinkhole, depression, or vertical settlement which has moisture, seepage, or flow present.
7.4 Sliding, sloughing, or bulging (other slope movements)		No evidence of sliding, sloughing, or bulging.	Evidence of sliding, sloughing, or bulging that is small, shallow, or does not involve the entire slope of the abutment.	Evidence of sliding, sloughing, or bulging which involves the entire slope of the abutment from dam crest to toe.
7.5 Surface erosion		No erosion observed on the abutment.	Areas of minor erosion observed along the abutment less than 6 inches deep and less than 1 foot wide.	Erosion of the abutment which is greater than 6 inches deep or greater than 1 foot wide or that has the potential to back cut into the crest of the embankment.
7.6 Animal burrows or other damage from wildlife		No evidence of animal burrows or other damage caused by wildlife observed. Animal deterrent boxes are filled with poison.	Animal burrows less than 6 inches in depth anywhere on the slope of the embankment without visible signs of seepage, or embankment distress (e.g., cracking slumping, settlement). Animal deterrent boxes are lacking poison.	Animal burrows greater than 6 inches in depth observed anywhere on the slope of the embankment or animal burrows are observed with visible signs of seepage, or embankment distress (e.g., cracking slumping, settlement).





Rattlesnake Canyon Dam Safety Inspection Report

8. Toe of Dam, Left Side	Assigned Value	1	2	3
8.1 Seepage, boils, or standing water at or beyond the toe of the embankment		No evidence of seepage, boils, or standing water observed at or beyond the toe of the embankment.	Small, damp areas observed at or beyond the toe of the embankment observed. Areas of seepage around the toe of the embankment during "sunny day" conditions and clear water indicating no sediment transport around the spillway.	Seepage, boils, or standing water at or beyond the toe of the embankment observed. Active seepage observed at the toe of the embankment during "sunny day" conditions and cloudy water indicating sediment transport.
8.2 Cracking		No cracks or minor surficial cracks less than ¼" wide that have no observable pattern indicative of movement along a buried pipe.	Cracking greater than ¼" wide along a buried pipe which indicate a new or progressing instability along the buried pipe.	Cracking greater than ¼" wide that is progressing or changing along the buried pipe indicating an active instability of the embankment.
8.3 Heave or uplift at or beyond the toe of the embankment		No heave or uplift at or beyond the toe of the embankment observed.	Localized areas of heave or uplift that are unlikely to be associated with embankment instability.	Areas of heave or uplift that indicate a potential large-scale instability of the embankment.
8.4 Settlement, sinkholes, or other depressions (enhanced risk along pipe alignments)		No sinkholes, depressions, or settlement observed.	Dry sinkhole, depression, or vertical settlement 6 inches or less in depth and less than 3 feet in diameter observed.	Dry sinkhole, depression, or vertical settlement greater than 6 inches in depth or greater than 3 feet in diameter observed or any sinkhole, depression, or vertical settlement which has moisture, seepage, or flow present.
8.5 Animal burrows or other damage from wildlife		No evidence of animal burrows or other damage caused by wildlife observed. Animal deterrent boxes are filled with poison.	Animal burrows less than 6 inches in depth anywhere on the slope of the embankment without visible signs of seepage, or embankment distress (e.g., cracking slumping, settlement). Animal deterrent boxes are lacking poison.	Animal burrows greater than 6 inches in depth observed anywhere on the slope of the embankment or animal burrows are observed with visible signs of seepage, or embankment distress (e.g., cracking slumping, settlement).
8.6 Visible parts of drainage system		Discharge pipes have no corrosion.	Discharge pipes have minor corrosion, but full function of the system remains.	Discharge pipes have major corrosion and function of the system is impaired.
8.7 Emergency spillway outlet pipe		Emergency spillway outlet pipe has no corrosion.	Emergency spillway outlet pipe has minor corrosion, but full function of the system remains.	Emergency spillway outlet pipe has major corrosion and function of the system is impaired.

Rattlesnake Canyon Dam Safety Inspection Report

9. Toe of Dam, Right Side	Assigned Value	1	2	3
9.1 Seepage, boils, or standing water at or beyond the toe of the embankment		No evidence of seepage, boils, or standing water observed at or beyond the toe of the embankment.	Small, damp areas observed at or beyond the toe of the embankment observed. Areas of seepage around the toe of the embankment during "sunny day" conditions and clear water indicating no sediment transport around the spillway.	Seepage, boils, or standing water at or beyond the toe of the embankment observed. Active seepage observed at the toe of the embankment during "sunny day" conditions and cloudy water indicating sediment transport.
9.2 Cracking		No cracks or minor surficial cracks less than 1/4" wide that have no observable pattern indicative of movement along a buried pipe.	Cracking greater than 1/4" wide along a buried pipe which indicate a new or progressing instability along the buried pipe.	Cracking greater than 1/4" wide that is progressing or changing along the buried pipe indicating an active instability of the embankment.
9.3 Heave or uplift at or beyond the toe of the embankment		No heave or uplift at or beyond the toe of the embankment observed.	Localized areas of heave or uplift that are unlikely to be associated with embankment instability.	Areas of heave or uplift that indicate a potential large-scale instability of the embankment.
9.4 Settlement, sinkholes, or other depressions (enhanced risk along pipe alignments)		No sinkholes, depressions, or settlement observed.	Dry sinkhole, depression, or vertical settlement 6 inches or less in depth and less than 3 feet in diameter observed.	Dry sinkhole, depression, or vertical settlement greater than 6 inches in depth or greater than 3 feet in diameter observed or any sinkhole, depression, or vertical settlement which has moisture, seepage, or flow present.
9.5 Animal burrows or other damage from wildlife		No evidence of animal burrows or other damage caused by wildlife observed. Animal deterrent boxes are filled with poison.	Animal burrows less than 6 inches in depth anywhere on the slope of the embankment without visible signs of seepage, or embankment distress (e.g., cracking slumping, settlement). Animal deterrent boxes are lacking poison.	Animal burrows greater than 6 inches in depth observed anywhere on the slope of the embankment or animal burrows are observed with visible signs of seepage, or embankment distress (e.g., cracking slumping, settlement).
9.6 Access road		Road surface is even with no rutting, wash boarding, or erosion.	Areas of minor rutting, wash boarding, or erosion but vehicle access is not impaired.	Areas of rutting, wash boarding, or erosion which limits vehicle access to the dam.

Rattlesnake Canyon Dam Safety Inspection Report

10. Spillway	Assigned Value	1	2	3
10.1 Concrete condition (movement or offsets at joints, cracking, pitting, breakage)		Negligible joint movement, cracking, pitting, breakage, or spalling.	Localized spalling, scaling, or cracking observed.	Widespread spalling, scaling, or cracking present.
10.2 Sidewall drains		No debris or vegetation observed in the sidewall drains.	Debris and vegetation obstructing less than half of the capacity in the sidewall drains. Debris observed will wash away in an event where half of the capacity of the drains is required.	Significant debris or vegetation is present in the sidewall drains that could significantly compromise the performance of the sidewall drains.
10.3 Vegetation		No weeds, shrubs, sediment, or trees observed growing in the liner.	Sediment, trees less than ¼" in diameter, brush, or other vegetation growing in the liner that may impede the free flow of water.	Shrubs or trees larger than ¼ "diameter observed growing in the liner.
10.4 Animal burrows or other damage from wildlife		No evidence of animal burrows or other damage caused by wildlife observed. Animal deterrent boxes are filled with poison.	Animal burrows less than 6 inches in depth anywhere on the slope of the embankment without visible signs of seepage, or embankment distress (e.g., cracking slumping, settlement). Animal deterrent boxes are lacking poison.	Animal burrows greater than 6 inches in depth observed anywhere on the slope of the embankment or animal burrows are observed with visible signs of seepage, or embankment distress (e.g., cracking slumping, settlement).
10.5 Erosion or undermining at concrete inlet		No active erosion or scouring around the concrete structures.	Localized areas of erosion or scouring around the concrete structures less than 1 foot deep in any direction.	Widespread erosion or scouring leading to large or long unsupported sections of concrete.
10.6 Condition of inlet (potential blockages or vegetation)		Inlet is clear of debris that would inhibit flow.	Inlet is blocked by debris, but the blockage is likely to be washed away in a high flow event.	Inlet may become blocked such that flow capacity would be impeded during a high flow event or greater than 25% of the spillway could be blocked by vegetation or other obstructions.
10.7 Condition of spillway approach (potential blockages or vegetation)		Inlet is clear of debris that would inhibit flow.	Inlet is blocked by debris, but the blockage is likely to be washed away in a high flow event.	Inlet may become blocked such that flow capacity would be impeded during a high flow event or greater than 25% of the spillway could be blocked by vegetation or other obstructions. Woody vegetation is observed.
10.8 Condition of spillway approach cracking		No cracks or minor surficial cracks less than ¼" wide that have no observable pattern indicative of slope movement or failure.	Cracking greater than ¼" wide along the embankment crest, or along the alignment of pipes which may indicate a new or progressing instability of the embankment.	Cracking greater than ¼" wide that is progressing or changing along the embankment crest, or along the alignment of pipes that may indicate an active instability of the embankment.
10.9 Erosion or undermining at spillway outlet		No active erosion or scouring around the concrete structures.	Areas of erosion or scouring around the concrete structures less than 1 foot deep in any direction.	Erosion or scouring leading to large or long unsupported sections of concrete.
10.10 Seepage around or underneath spillway slab		No evidence of seepage, damp areas, or boils are observed around the spillway alignment or beneath spillway slabs.	Areas of seepage around the spillway or flow at the toe of the spillway prior to a spill event and during "sunny day" conditions and clear water indicating no sediment transport around the spillway.	Active seepage observed outside of the spillway or at the toe of the spillway prior to a spill event and during "sunny day" conditions and cloudy water indicating sediment transport.
 Spillway channel	 Spillway crest		 Spillway approach	 Energy dissipator

Section 2: Instrumentation Observations and Measurements

Crack measurements, drain and seepage flows, and instrumentation readings are not recorded on this report, they are tracked by IRWD Operations staff using Microsoft Teams and spreadsheets.

Reservoir / Upstream

1. Crack measurements taken on the liner.

Yes	No	Unknown	N/A
<input type="checkbox"/>	<input type="checkbox"/>	<input type="checkbox"/>	<input type="checkbox"/>

Drainage Elements and Weirs

1. Flow measurements obtained.
2. Measured flow from the drains is within normal and expected range.
3. Seepage water is clear.
4. Grab Samples Obtained
5. Alarm float in MH #1 is in good working condition.

<input type="checkbox"/>	<input type="checkbox"/>	<input type="checkbox"/>	<input type="checkbox"/>
<input type="checkbox"/>	<input type="checkbox"/>	<input type="checkbox"/>	<input type="checkbox"/>
<input type="checkbox"/>	<input type="checkbox"/>	<input type="checkbox"/>	<input type="checkbox"/>
<input type="checkbox"/>	<input type="checkbox"/>	<input type="checkbox"/>	<input type="checkbox"/>
<input type="checkbox"/>	<input type="checkbox"/>	<input type="checkbox"/>	<input type="checkbox"/>

Piezometers and Groundwater Levels

1. Piezometer measurement taken.
2. Piezometer results within normal and expected range.
3. Piezometers are in good working condition.
4. Piezometer Spreadsheet was populated.

<input type="checkbox"/>	<input type="checkbox"/>	<input type="checkbox"/>	<input type="checkbox"/>
<input type="checkbox"/>	<input type="checkbox"/>	<input type="checkbox"/>	<input type="checkbox"/>
<input type="checkbox"/>	<input type="checkbox"/>	<input type="checkbox"/>	<input type="checkbox"/>
<input type="checkbox"/>	<input type="checkbox"/>	<input type="checkbox"/>	<input type="checkbox"/>
<input type="checkbox"/>	<input type="checkbox"/>	<input type="checkbox"/>	<input type="checkbox"/>

Section 3: Annual or Periodic Inspection

 N/A

Inspection Items

1. Valves are in good working condition and were exercised during the inspection.
2. Drain vaults inspected and in good working condition.
3. Survey completed
4. Drone (UAV) flight completed (3–5-year frequency or as required).
5. Remotely Operated Vehicle (ROV) inspection completed (3–5-year frequency or as required).
6. Emergency outlet valve was exercised and is in good condition.

Yes	No	Unknown	N/A
-----	----	---------	-----

<input type="checkbox"/>	<input type="checkbox"/>	<input type="checkbox"/>	<input type="checkbox"/>
<input type="checkbox"/>	<input type="checkbox"/>	<input type="checkbox"/>	<input type="checkbox"/>
<input type="checkbox"/>	<input type="checkbox"/>	<input type="checkbox"/>	<input type="checkbox"/>
<input type="checkbox"/>	<input type="checkbox"/>	<input type="checkbox"/>	<input type="checkbox"/>
<input type="checkbox"/>	<input type="checkbox"/>	<input type="checkbox"/>	<input type="checkbox"/>
<input type="checkbox"/>	<input type="checkbox"/>	<input type="checkbox"/>	<input type="checkbox"/>

If exercised, note the approximate volume discharge: _____

7. Aeration system was inspected and is in good condition.

<input type="checkbox"/>	<input type="checkbox"/>	<input type="checkbox"/>	<input type="checkbox"/>
--------------------------	--------------------------	--------------------------	--------------------------

Section 4: Event Driven Inspection

 N/A

Event driven inspections include observations following earthquake or storm events. These inspections are performed based on the event thresholds established by IRWD.

Earthquake

1. Was the earthquake felt at the site? If so, complete the line below.

Date: _____ Time: _____ Magnitude: _____ Distance (miles): _____

Yes	No	Unknown	N/A
<input type="checkbox"/>	<input type="checkbox"/>	<input type="checkbox"/>	<input type="checkbox"/>

2. Was the epicenter of the earthquake within 75 miles of the dam with a magnitude of 4.0 or greater?
3. Were new cracks, sinkholes, depressions, or new/unusual settlement identified during the inspection?
4. Have existing cracks, sinkholes, depressions, or areas of unusual settlement changed since the last inspection?

<input type="checkbox"/>	<input type="checkbox"/>	<input type="checkbox"/>	<input type="checkbox"/>
<input type="checkbox"/>	<input type="checkbox"/>	<input type="checkbox"/>	<input type="checkbox"/>
<input type="checkbox"/>	<input type="checkbox"/>	<input type="checkbox"/>	<input type="checkbox"/>

Precipitation

1. Is water flowing through the spillway?
2. Are flows into and out of the reservoir performing as anticipated and not damaging structures and the dam?

Yes	No	Unknown	N/A
<input type="checkbox"/>	<input type="checkbox"/>	<input type="checkbox"/>	<input type="checkbox"/>
<input type="checkbox"/>	<input type="checkbox"/>	<input type="checkbox"/>	<input type="checkbox"/>

Section 5: Notes and Comments

Section 6: Items that require further action, attention, or monitoring (assigned values 2 or 3)

Item	Comment	Action	Confirmation # (if applicable)

Section 7: Sign Off

Changed Conditions

	Yes	No	Unknown	N/A
Have any conditions changed since the previous inspection?	<input type="checkbox"/>	<input type="checkbox"/>	<input type="checkbox"/>	<input type="checkbox"/>
Have areas of distress been identified during this inspection?	<input type="checkbox"/>	<input type="checkbox"/>	<input type="checkbox"/>	<input type="checkbox"/>

Water Operations Inspector: _____ Signature: _____ Date: _____

Water Operations Supervisor: _____ Signature: _____ Date: _____

Dam Safety Engineer: _____ Signature: _____ Date: _____

C:\Users\cstege\OneDrive - Stantec\Desktop\IRWD_Export\IRWD_Figures\IRWD_Figures.aprx Dam_Overview Revised: 2023-05-27 By: cstege



- Legend
- A Piezometer
 - ◆ Rain Gauge
 - Emergency Outlet
 - ⬠ Seepage Collection Vault
 - Outlet Pipe
 - ⊘ Area Number
 - Left Abutment
 - Right Abutment
 - Dam Crest and Upstream
 - Embankment, Left Side
 - Dam Crest and Upstream Embankment, Right Side
 - Downstream Embankment, Left Side
 - Downstream Embankment, Right Side
 - Toe of Dam, Left Side (Stability Berm)
 - Toe of Dam, Right Side
 - Energy Dissipator
 - Spillway Approach
 - Spillway Channel
 - Spillway Crest

- Notes
1. Coordinate System: NAD 1983 StatePlane California VI FIPS 0406 Feet
 2. Data Sources: IRWD, Stantec
 3. Background: NAIP Imagery

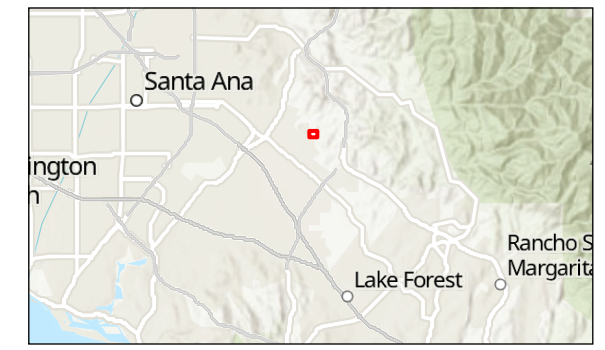
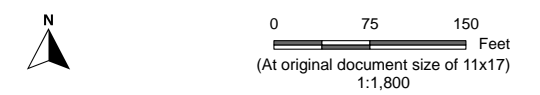

Project Location
Irvine, CA

Prepared by CS on 2/27/2023
TR by CB on 2/27/2023
IR by MD on 2/27/2023

Client/Project
Irvine Ranch Water District
Dam Safety Program

Figure No.
1

Title
Rattlesnake Dam Overview

Santiago Creek Dam Safety Inspection Report

Inspector(s): _____ Inspection Date: _____

Weather Conditions: _____ Rain Gauge Reading: _____

 Reason for Inspection: Routine/Monthly Periodic Event-Driven Photos Taken: NO YES

Additional Comments: _____

Section 1: Visual Observations

Reservoir	Assigned Value	1	2	3
Assessment of the reservoir area and visible watershed.		No signs of erosion, sloughing, or leaned or fallen trees observed in the watershed upstream of the embankment.	Areas of minor erosion, sloughing, or leaned or fallen trees which do not impact the reservoir or storage but could pose a hazard to the reservoir or storage volume in time.	Erosion, sloughing, or landslides within the upstream watershed that have impacted the reservoir or storage volume.

Area 0. Left Abutment	Assigned Value	1	2	3
0.1 Seepage		No evidence of damp areas, seepage, or areas which are significantly "greener" or have flourishing vegetation.	Damp areas, seepage, or areas which are significantly "greener" or have flourishing vegetation and clear water indicating no sediment transport through the abutment.	Damp areas, seepage, or areas which are significantly "greener" or have flourishing vegetation and cloudy water indicating sediment transport through the abutment.
0.2 Cracking		No cracks or minor surficial cracks less than 1/4" wide that have no observable pattern indicative of slope movement or failure.	Cracking greater than 1/4" wide along the abutment, which indicate a new or progressing instability of the abutment.	Cracking greater than 1/4" wide that is progressing or changing along the abutment.
0.3 Settlement, sinkholes, or other depressions (enhanced risk along pipe alignments)		No sinkholes, depressions, or settlement observed.	Dry sinkhole, depression, or vertical settlement 6 inches or less in depth and less than 3 feet in diameter observed.	Dry sinkhole, depression, or vertical settlement greater than 6 inches in depth or greater than 3 feet in diameter observed or any sinkhole, depression, or vertical settlement which has moisture, seepage, or flow present.
0.4 Sliding, sloughing, or bulging (other slope movements)		No evidence of sliding, sloughing, or bulging.	Evidence of sliding, sloughing, which does not involve the entire slope of the abutment.	Evidence of sliding, sloughing, or bulging which involves the entire slope of the abutment from dam crest to toe.
0.5 Surface erosion		No erosion observed on the abutment.	Areas of minor erosion observed along the abutment less than 6 inches deep and less than 1 foot wide.	Erosion of the abutment which is greater than 6 inches deep or greater than 1 foot wide or that has the potential to back cut into the crest of the embankment.

Santiago Creek Dam Safety Inspection Report

Area 1. Spillway	Assigned Value	1	2	3
1.1 Concrete condition (movement or offsets at joints, cracking, pitting, breakage)		Negligible joint movement, cracking, pitting, breakage, or spalling.	Localized spalling, scaling, or cracking observed.	Widespread spalling, scaling, or cracking present.
1.2 Sliding, sloughing, or bulging (slope above spillway)		No evidence of sliding, sloughing, or bulging.	Evidence of sliding, sloughing, or bulging that is small, shallow, or does not impact the spillway.	Evidence of sliding, sloughing, or bulging which impacts the spillway.
1.3 Surface erosion (slope above spillway)		No erosion observed on the slope.	Areas of minor erosion observed on the slope less than 6 inches deep and less than 1 foot wide but does not impact the spillway.	Erosion of the slope which is greater than 6 inches deep or greater than 1 foot wide or that has the potential to impact the spillway.
1.4 Erosion or undermining at the gates		No active erosion or scouring around the concrete structures.	Localized areas of erosion or scouring around the concrete structures less than 1 foot deep in any direction.	Widespread erosion or scouring leading to large or long unsupported sections of concrete.
1.5 Condition of inlet at the gates (potential blockages or vegetation)		Inlet is clear of debris that would inhibit flow.	Inlet is blocked by debris, but the blockage is likely to be washed away in a high flow event.	Inlet may become blocked such that flow capacity would be impeded during a high flow event or greater than 25% of the spillway could be blocked by vegetation or other obstructions.
1.6 Condition of spillway approach (potential blockages or vegetation)		Inlet is clear of debris that would inhibit flow.	Inlet is blocked by debris, but the blockage is likely to be washed away in a high flow event.	Inlet may become blocked such that flow capacity would be impeded during a high flow event or greater than 25% of the spillway could be blocked by vegetation or other obstructions. Woody vegetation is observed.
1.7 Erosion or undermining at spillway outlet		No active erosion or scouring around the concrete structures.	Areas of erosion or scouring around the concrete structures less than 1 foot deep in any direction.	Erosion or scouring leading to large or long unsupported sections of concrete.
1.8 Seepage around or underneath spillway slab		No evidence of seepage, damp areas, or boils are observed around the spillway alignment or beneath spillway slabs.	Areas of seepage around the spillway or flow at the toe of the spillway prior to a spill event and during "sunny day" conditions and clear water indicating no sediment transport around the spillway.	Active seepage observed outside of the spillway or at the toe of the spillway prior to a spill event and during "sunny day" conditions and cloudy water indicating sediment transport.

 Spillway channel

 Spillway crest

 Spillway approach

 Energy dissipator

Santiago Creek Dam Safety Inspection Report

Area 3. Dam Crest and Upstream Embankment, Left Side	Assigned Value	1	2	3
3.1 Cracking		No cracks or minor surficial cracks less than ¼" wide that have no observable pattern indicative of slope movement or failure.	Cracking greater than ¼" wide along the embankment crest, or along the alignment of pipes which may indicate a new or progressing instability of the embankment.	Cracking greater than ¼" wide that is progressing or changing along the embankment crest, or along the alignment of pipes that may indicate an active instability of the embankment.
3.2 Vegetation		Liner is free of weeds and trash. No shrubs or trees observed growing in the liner.	Weeds or trash observed on the liner.	Shrubs or trees growing in the liner.
3.3 Animal burrows or other damage from wildlife		No evidence of animal burrows or other damage caused by wildlife observed. Animal deterrent boxes are filled with poison.	Animal burrows less than 6 inches in depth anywhere on the slope of the embankment without visible signs of seepage, or embankment distress (e.g., cracking slumping, settlement). Animal deterrent boxes are lacking poison.	Animal burrows greater than 6 inches in depth observed anywhere on the slope of the embankment or animal burrows are observed with visible signs of seepage, or embankment distress (e.g., cracking slumping, settlement).

Santiago Creek Dam Safety Inspection Report

Area 4. Downstream Embankment, Left Side	Assigned Value	1	2	3
4.1 Seepage		No evidence of damp areas, seepage, or areas which are significantly "greener" or have flourishing vegetation.	Damp areas, seepage, or areas which are significantly "greener" or have flourishing vegetation and clear water indicating no sediment transport through the embankment.	Damp areas, of seepage, or areas which are significantly "greener" or have flourishing vegetation and cloudy water indicating sediment transport through the embankment.
4.2 Cracking		No cracks or minor surficial cracks less than ¼" wide that have no observable pattern indicative of slope movement or failure.	Cracking greater than ¼" wide along the embankment crest, or along the alignment of pipes which indicate a new or progressing instability of the embankment.	Cracking greater than ¼" wide that is progressing or changing along the embankment crest, or along the alignment of pipes indicating an active instability of the embankment.
4.3 Settlement, sinkholes, or other depressions (enhanced risk along pipe alignments)		No sinkholes, depressions, or settlement observed.	Dry sinkhole, depression, or vertical settlement 6 inches or less in depth and less than 3 feet in diameter observed.	Dry sinkhole, depression, or vertical settlement greater than 6 inches in depth or greater than 3 feet in diameter observed or any sinkhole, depression, or vertical settlement which has moisture, seepage, or flow present.
4.4 Sliding, sloughing, or bulging (other slope movements)		No evidence of sliding, sloughing, or bulging.	Evidence of sliding, sloughing, which does not involve the entire downstream slope of the embankment.	Evidence of sliding, sloughing, or bulging which involves the entire slope of the embankment from crest to toe.
4.5 Surface erosion		No erosion observed on the embankment.	Areas of minor erosion observed along downstream slope of the embankment less than 6 inches deep and less than 1 foot wide.	Erosion of the downstream face or the embankment which is greater than 6 inches deep or greater than 1 foot wide or that has the potential to back cut into the crest of the embankment.
4.6 Vegetation		Weeds or grasses are maintained at 6 inches in height or less. No woody vegetation observed. Embankment is free of vegetation such that the face of the embankment is clearly visible from the established inspection routes.	Weeds or grasses are greater than 6 inches in height. Vegetation which impedes up to 25% of the visual inspection of the embankment and limits observation of the embankment from the established inspection routes or woody vegetation is observed.	Vegetation which impedes greater than 25% of the visual inspection of the embankment and limits observation of the embankment from the established inspection routes.
4.7 Animal burrows or other damage from wildlife		No evidence of animal burrows or other damage caused by wildlife observed. Animal deterrent boxes are filled with poison.	Animal burrows less than 6 inches in depth anywhere on the slope of the embankment without visible signs of seepage, or embankment distress (e.g., cracking slumping, settlement). Animal deterrent boxes are lacking poison.	Animal burrows greater than 6 inches in depth observed anywhere on the slope of the embankment or animal burrows are observed with visible signs of seepage, or embankment distress (e.g., cracking slumping, settlement).

Santiago Creek Dam Safety Inspection Report

Area 5. Toe of Dam, Left Side	Assigned Value	1	2	3
5.1 Seepage, boils, or standing water at or beyond the toe of the embankment		No evidence of seepage, boils, or standing water observed at or beyond the toe of the embankment.	Small, damp areas observed at or beyond the toe of the embankment observed. Areas of seepage around the toe of the embankment during “sunny day” conditions and clear water indicating no sediment transport around the spillway.	Seepage, boils, or standing water at or beyond the toe of the embankment observed. Active seepage observed at the toe of the embankment during “sunny day” conditions and cloudy water indicating sediment transport.
5.2 Cracking		No cracks or minor surficial cracks less than ¼” wide that have no observable pattern indicative of movement along a buried pipe.	Cracking greater than ¼” wide along a buried pipe which indicate a new or progressing instability along the buried pipe.	Cracking greater than ¼” wide that is progressing or changing along the buried pipe indicating an active instability of the embankment.
5.3 Heave or uplift at or beyond the toe of the embankment		No heave or uplift at or beyond the toe of the embankment observed.	Localized areas of heave or uplift that are unlikely to be associated with embankment instability.	Areas of heave or uplift that indicate a potential large-scale instability of the embankment.
5.4 Settlement, sinkholes, or other depressions (enhanced risk along pipe alignments)		No sinkholes, depressions, or settlement observed.	Dry sinkhole, depression, or vertical settlement 6 inches or less in depth and less than 3 feet in diameter observed.	Dry sinkhole, depression, or vertical settlement greater than 6 inches in depth or greater than 3 feet in diameter observed or any sinkhole, depression, or vertical settlement which has moisture, seepage, or flow present.
5.5 Animal burrows or other damage from wildlife		No evidence of animal burrows or other damage caused by wildlife observed. Animal deterrent boxes are filled with poison.	Animal burrows less than 6 inches in depth anywhere on the slope of the embankment without visible signs of seepage, or embankment distress (e.g., cracking slumping, settlement). Animal deterrent boxes are lacking poison.	Animal burrows greater than 6 inches in depth observed anywhere on the slope of the embankment or animal burrows are observed with visible signs of seepage, or embankment distress (e.g., cracking slumping, settlement).

Santiago Creek Dam Safety Inspection Report

Area 6. Toe of Dam, Right Side	Assigned Value	1	2	3
6.1 Seepage, boils, or standing water at or beyond the toe of the embankment		No evidence of seepage, boils, or standing water observed at or beyond the toe of the embankment.	Small, damp areas observed at or beyond the toe of the embankment observed. Areas of seepage around the toe of the embankment during “sunny day” conditions and clear water indicating no sediment transport around the spillway.	Seepage, boils, or standing water at or beyond the toe of the embankment observed. Active seepage observed at the toe of the embankment during “sunny day” conditions and cloudy water indicating sediment transport.
6.2 Cracking		No cracks or minor surficial cracks less than ¼” wide that have no observable pattern indicative of movement along a buried pipe.	Cracking greater than ¼” wide along a buried pipe which indicate a new or progressing instability along the buried pipe.	Cracking greater than ¼” wide that is progressing or changing along the buried pipe indicating an active instability of the embankment.
6.3 Heave or uplift at or beyond the toe of the embankment		No heave or uplift at or beyond the toe of the embankment observed.	Localized areas of heave or uplift that are unlikely to be associated with embankment instability.	Areas of heave or uplift that indicate a potential large-scale instability of the embankment.
6.4 Settlement, sinkholes, or other depressions (enhanced risk along pipe alignments)		No sinkholes, depressions, or settlement observed.	Dry sinkhole, depression, or vertical settlement 6 inches or less in depth and less than 3 feet in diameter observed.	Dry sinkhole, depression, or vertical settlement greater than 6 inches in depth or greater than 3 feet in diameter observed or any sinkhole, depression, or vertical settlement which has moisture, seepage, or flow present.
6.5 Animal burrows or other damage from wildlife		No evidence of animal burrows or other damage caused by wildlife observed. Animal deterrent boxes are filled with poison.	Animal burrows less than 6 inches in depth anywhere on the slope of the embankment without visible signs of seepage, or embankment distress (e.g., cracking slumping, settlement). Animal deterrent boxes are lacking poison.	Animal burrows greater than 6 inches in depth observed anywhere on the slope of the embankment or animal burrows are observed with visible signs of seepage, or embankment distress (e.g., cracking slumping, settlement).

Santiago Creek Dam Safety Inspection Report

Area 7. Downstream Embankment, Right Side	Assigned Value	1	2	3
7.1 Seepage		No evidence of damp areas, seepage, or areas which are significantly "greener" or have flourishing vegetation.	Damp areas, seepage, or areas which are significantly "greener" or have flourishing vegetation and clear water indicating no sediment transport through the embankment.	Damp areas, seepage, or areas which are significantly "greener" or have flourishing vegetation and cloudy water indicating sediment transport through the embankment.
7.2 Cracking		No cracks or minor surficial cracks less than ¼" wide that have no observable pattern indicative of slope movement or failure.	Cracking greater than ¼" wide along the embankment crest, or along the alignment of pipes which indicate a new or progressing instability of the embankment.	Cracking greater than ¼" wide that is progressing or changing along the embankment crest, or along the alignment of pipes indicating an active instability of the embankment.
7.3 Settlement, sinkholes, or other depressions (enhanced risk along pipe alignments)		No sinkholes, depressions, or settlement observed.	Dry sinkhole, depression, or vertical settlement 6 inches or less in depth and less than 3 feet in diameter observed.	Dry sinkhole, depression, or vertical settlement greater than 6 inches in depth or greater than 3 feet in diameter observed or any sinkhole, depression, or vertical settlement which has moisture, seepage, or flow present.
7.4 Sliding, sloughing, or bulging (other slope movements)		No evidence of sliding, sloughing, or bulging.	Evidence of sliding, sloughing, which does not involve the entire downstream slope of the embankment.	Evidence of sliding, sloughing, or bulging which involves the entire slope of the embankment from crest to toe.
7.5 Surface erosion		No erosion observed on the embankment.	Areas of minor erosion observed along downstream slope of the embankment less than 6 inches deep and less than 1 foot wide.	Erosion of the downstream face or the embankment which is greater than 6 inches deep or greater than 1 foot wide or that has the potential to back cut into the crest of the embankment.
7.6 Vegetation		Weeds or grasses are maintained at 6 inches in height or less. No woody vegetation observed. Embankment is free of vegetation such that the face of the embankment is clearly visible from the established inspection routes.	Weeds or grasses are greater than 6 inches in height. Vegetation which impedes up to 25% of the visual inspection of the embankment and limits observation of the embankment from the established inspection routes or woody vegetation is observed.	Vegetation which impedes greater than 25% of the visual inspection of the embankment and limits observation of the embankment from the established inspection routes.
7.7 Animal burrows or other damage from wildlife		No evidence of animal burrows or other damage caused by wildlife observed. Animal deterrent boxes are filled with poison.	Animal burrows less than 6 inches in depth anywhere on the slope of the embankment without visible signs of seepage, or embankment distress (e.g., cracking slumping, settlement). Animal deterrent boxes are lacking poison.	Animal burrows greater than 6 inches in depth observed anywhere on the slope of the embankment or animal burrows are observed with visible signs of seepage, or embankment distress (e.g., cracking slumping, settlement).

Santiago Creek Dam Safety Inspection Report

Area 8. Dam Crest and Upstream Embankment, Right Side	Assigned Value	1	2	3
8.1 Cracking		No cracks or minor surficial cracks less than 1/4" wide that have no observable pattern indicative of slope movement or failure.	Cracking greater than 1/4" wide along the embankment crest, or along the alignment of pipes which indicate a new or progressing instability of the embankment.	Cracking greater than 1/4" wide that is progressing or changing along the embankment crest, or along the alignment of pipes indicating an active instability of the embankment.
8.2 Vegetation		Liner is free of weeds and trash. No shrubs or trees observed growing in the liner.	Weeds or trash observed on the liner.	Shrubs or trees growing in the liner.
8.3 Animal burrows or other damage from wildlife		No evidence of animal burrows or other damage caused by wildlife observed. Animal deterrent boxes are filled with poison.	Animal burrows less than 6 inches in depth anywhere on the slope of the embankment without visible signs of seepage, or embankment distress (e.g., cracking slumping, settlement). Animal deterrent boxes are lacking poison.	Animal burrows greater than 6 inches in depth observed anywhere on the slope of the embankment or animal burrows are observed with visible signs of seepage, or embankment distress (e.g., cracking slumping, settlement).

Santiago Creek Dam Safety Inspection Report

Area 9. Right Abutment	Assigned Value	1	2	3
9.1 Seepage		No evidence of damp areas, seepage, or areas which are significantly "greener" or have flourishing vegetation.	Damp areas, seepage, or areas which are significantly "greener" or have flourishing vegetation and clear water indicating no sediment transport through the abutment.	Damp areas, seepage, or areas which are significantly "greener" or have flourishing vegetation and cloudy water indicating sediment transport through the abutment.
9.2 Cracking		No cracks or minor surficial cracks less than ¼" wide that have no observable pattern indicative of slope movement or failure.	Cracking greater than ¼" wide along the abutment, which indicate a new or progressing instability of the abutment.	Cracking greater than ¼" wide that is progressing or changing along the abutment.
9.3 Settlement, sinkholes, or other depressions (enhanced risk along pipe alignments)		No sinkholes, depressions, or settlement observed.	Dry sinkhole, depression, or vertical settlement 6 inches or less in depth and less than 3 feet in diameter observed.	Dry sinkhole, depression, or vertical settlement greater than 6 inches in depth or greater than 3 feet in diameter observed or any sinkhole, depression, or vertical settlement which has moisture, seepage, or flow present.
9.4 Sliding, sloughing, or bulging (other slope movements)		No evidence of sliding, sloughing, or bulging.	Evidence of sliding, sloughing, or bulging that is small, shallow, or does not involve the entire slope of the abutment.	Evidence of sliding, sloughing, or bulging which involves the entire slope of the abutment from dam crest to toe.
9.5 Surface erosion		No erosion observed on the abutment.	Areas of minor erosion observed along the abutment less than 6 inches deep and less than 1 foot wide.	Erosion of the abutment which is greater than 6 inches deep or greater than 1 foot wide or that has the potential to back cut into the crest of the embankment.
9.6 Animal burrows or other damage from wildlife		No evidence of animal burrows or other damage caused by wildlife observed. Animal deterrent boxes are filled with poison.	Animal burrows less than 6 inches in depth anywhere on the slope of the embankment without visible signs of seepage, or embankment distress (e.g., cracking slumping, settlement). Animal deterrent boxes are lacking poison.	Animal burrows greater than 6 inches in depth observed anywhere on the slope of the embankment or animal burrows are observed with visible signs of seepage, or embankment distress (e.g., cracking slumping, settlement).



Section 2: Instrumentation Observations and Measurements

Crack measurements, drain and seepage flows, and instrumentation readings are not recorded on this report, they are tracked by IRWD Operations staff using Microsoft Teams and spreadsheets.

Reservoir / Upstream

- 1. Crack measurements taken on the liner.

Yes No Unknown N/A
[] [] [] []

Piezometers and Groundwater Levels

- 1. Piezometer measurement taken.
2. Piezometer results within normal and expected range.
3. Piezometers are in good working condition.
4. Piezometer spreadsheet was populated.

Yes No Unknown N/A
[] [] [] []
[] [] [] []
[] [] [] []
[] [] [] []

Section 3: Annual or Periodic Inspection

[] N/A

Periodic inspections are detailed inspections which require access to the drain vaults for inspection and sediment clean out, as well as valve exercising. The items below may be completed at different intervals; not all periodic inspection items need to be checked off during a single inspection.

Inspection Items

- 1. Inlet tower valves are in good working condition and were exercised during the inspection.
2. Survey completed
3. Drone (UAV) flight completed (3-5-year frequency or as required).
4. Remotely Operated Vehicle (ROV) inspection completed (3-5-year frequency or as required).
5. Emergency outlet valve was exercised and is in good condition.

Yes No Unknown N/A
[] [] [] []
[] [] [] []
[] [] [] []
[] [] [] []
[] [] [] []

If exercised, note the approximate volume discharge: _____

- 6. Aeration system was inspected and is in good condition.

[] [] [] []

Section 4: Event Driven Inspection

[] N/A

Event driven inspections include observations following earthquake or storm events. These inspections are performed based on the event thresholds established by IRWD.

Earthquake

- 1. Was the earthquake felt at the site? If so, complete the line below.

Yes No Unknown N/A
[] [] [] []

Date: _____ Time: _____ Magnitude: _____ Distance (miles): _____

- 2. Was the epicenter of the earthquake within 75 miles of the dam with a magnitude of 4.0 or greater?
3. Were new cracks, sinkholes, depressions, or new/unusual settlement identified during the inspection?
4. Have existing cracks, sinkholes, depressions, or areas of unusual settlement changed since the last inspection?

[] [] [] []
[] [] [] []
[] [] [] []

Precipitation

- 1. Is water flowing through the spillway?
2. Are flows into and out of the reservoir performing as anticipated and not damaging structures and the dam?

Yes No Unknown N/A
[] [] [] []
[] [] [] []



Section 5: Notes and Comments

Section 6: Items that require further action, attention, or monitoring (assigned values 2 or 3)

Inspection Item #	Comment	Action	Confirmation

Section 7: Sign Off

Changed Conditions

	Yes	No	Unknown	N/A
Have any conditions changed since the previous inspection?	<input type="checkbox"/>	<input type="checkbox"/>	<input type="checkbox"/>	<input type="checkbox"/>
Have areas of distress been identified during this inspection?	<input type="checkbox"/>	<input type="checkbox"/>	<input type="checkbox"/>	<input type="checkbox"/>

Water Operations Inspector: _____ Signature: _____ Date: _____

Water Operations Supervisor: _____ Signature: _____ Date: _____

Dam Safety Engineer: _____ Signature: _____ Date: _____

Legend

- A Piezometer
- ◆ Rain Gauge
- Emergency Outlet
- ▼ Outlet Tower and Outlet Valves
- # Area Number
- Left Abutment
- Right Abutment
- Dam Crest and Upstream
- Embankment, Left Side
- Dam Crest and Upstream Embankment, Right Side
- Downstream Embankment, Left Side
- Downstream Embankment, Right Side
- Toe of Dam, Left Side
- Toe of Dam, Right Side
- Energy Dissipator
- Spillway Approach
- Spillway Channel
- Spillway Gate

- Notes**
1. Coordinate System: NAD 1983 StatePlane California VI FIPS 0406 Feet
 2. Data Sources: IRWD, Stantec
 3. Background: NAIP Imagery

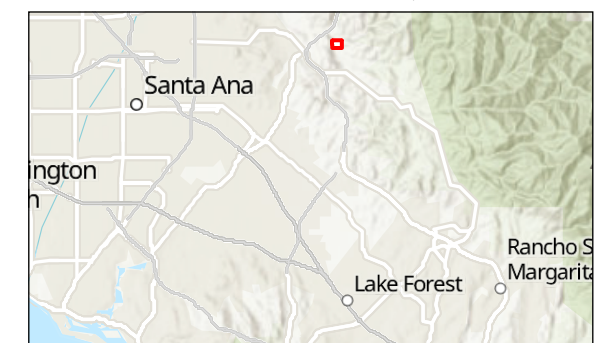
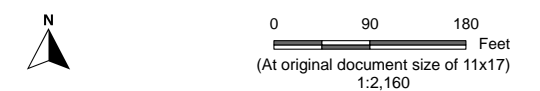

Project Location
Irvine, CA

Prepared by CS on 2/24/2023
TR by CB on 2/24/2023
IR by MD on 2/24/2023

Client/Project
Irvine Ranch Water District
Dam Safety Program

Figure No.
1

Title
Santiago Creek Dam Overview

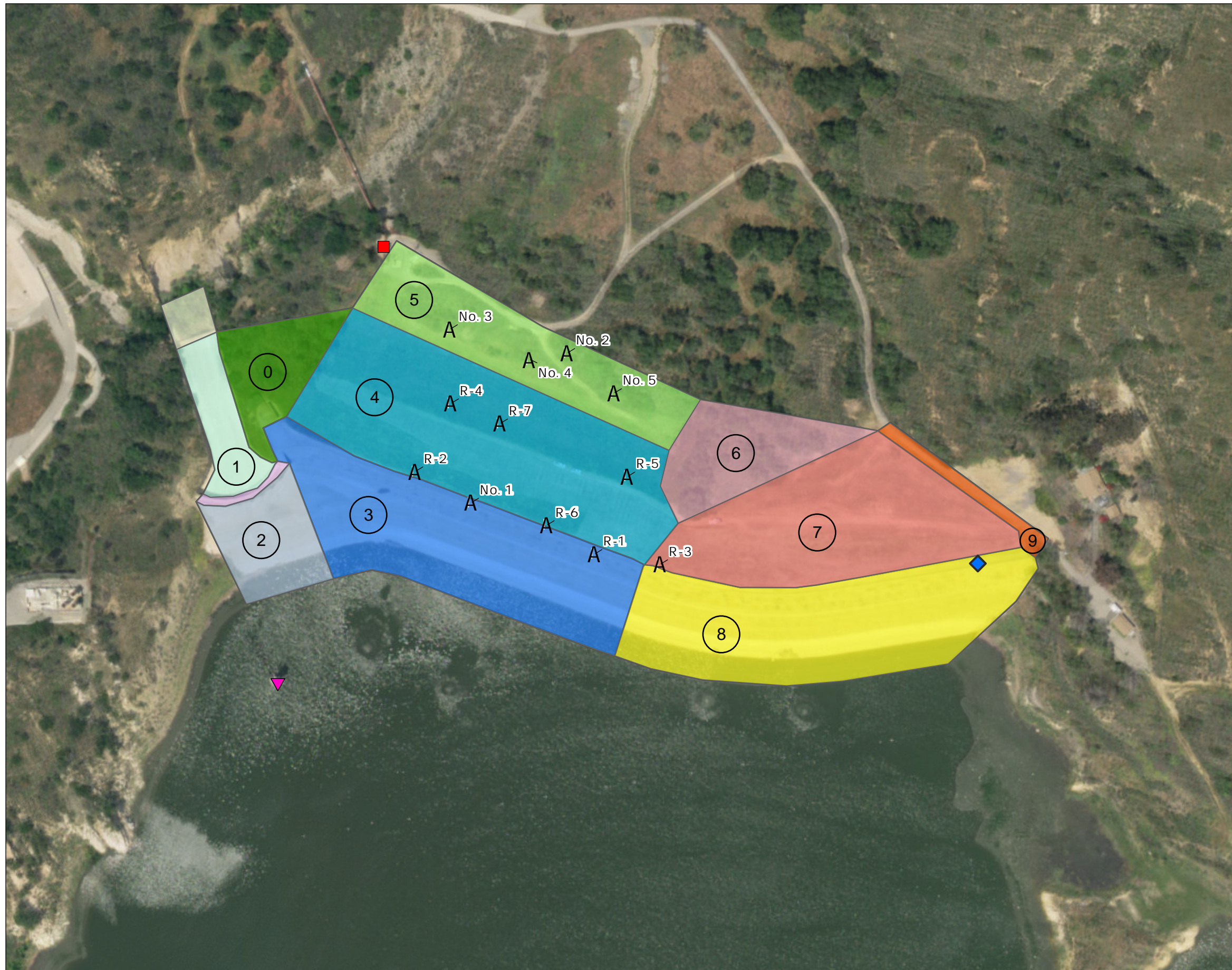

1.0 Purpose

The purpose of this document is to provide guidance for monitoring movement at Irvine Ranch Water District's (IRWD) dams.

2.0 Definitions

Below is a summary of terms used herein that are related to IRWD's Dam Safety Program (DSP).

Deformation - the action or process of changing shape.

Movement - the change in location or displacement of material or markers in the vertical and/or horizontal direction. Description of the of movement is shown in the below exhibit.

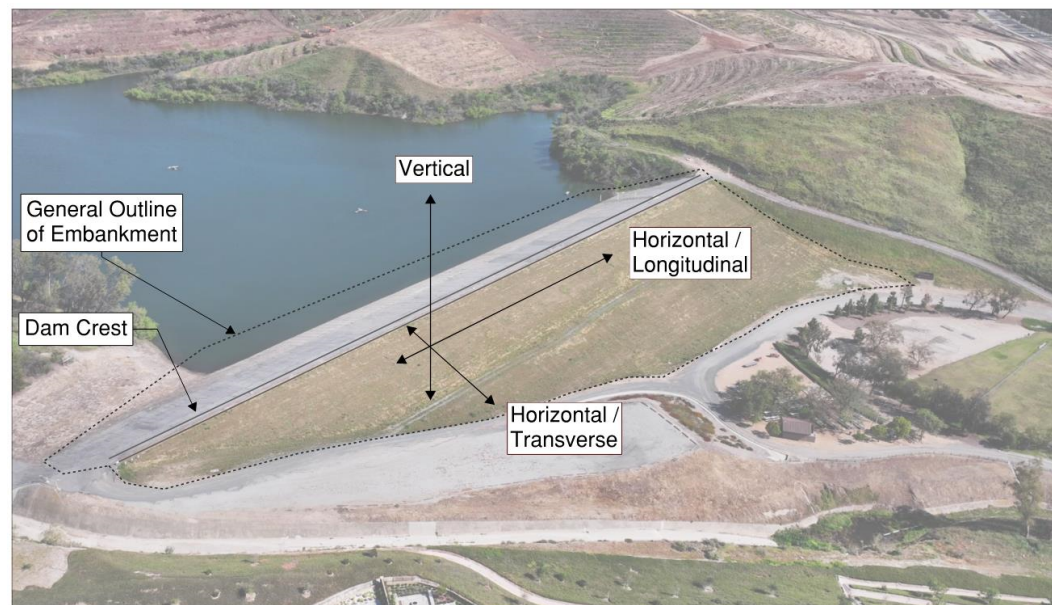

Figure 1: Description of directional movement/displacement.

3.0 Background

California's Division of Safety of Dams (DSOD) requires dam owners to conduct traditional land surveys annually to monitor ground movement. Monuments are installed along the dam crest and are utilized to measure horizontal and vertical movement of embankment dams. Recordings of movements could be early indications of deformation, settlement or other underlying concerns. Table 1 lists the number of survey monuments installed at each of IRWD's dams and the first year of survey data IRWD has on record.

Table 1: Summary of Survey Monuments		
Dam	Number of Survey Monuments	Oldest Survey on Record
San Joaquin	25	2004
Sand Canyon	5	1975
Syphon ¹	0	N/A
Rattlesnake	7	1985
Santiago Creek	5	1994
Harding Canyon	3	2023

¹Syphon Dam does not have survey monuments installed and historically has never been surveyed. Syphon Dam improvements are currently in design, which will include installation of traditional survey monuments.

The location of the survey monuments for each of the five dams with survey monuments are shown in the attached Exhibits 6.1 to 6.5.

4.0 General Guidelines

Movements occur in every dam, and it is caused by a variety of factors. The factors include, but are not limited to, stresses induced by the reservoir water pressure, unstable slopes from low shear strength, low foundation shear strength, settlement, expansion from temperature change, landslides, seismic activity, and heave resulting from hydrostatic uplift pressures. Conducting surveys and evaluating the collected data is the first step in understanding the direction of the movement and determining if additional monitoring is warranted. Depending on the level of movement and direction of the movement, additional instruments such as crack measuring devices, inclinometers, strain meters, or settlement plates may be required to better understanding the contributing factors to the movement. With a better understanding of the contributing factors, engineers can evaluate if a dam safety issue exists and if an Issue Evaluation Study is required.

4.1 Monitoring of Survey Monuments

Movement of dams can occur slowly overtime or quickly. Part of IRWD’s routine dam safety activities is annual surveys, which are used to track the movement at the survey monuments overtime. Surveys may also be required if an event, such as seismic activity, drives the need for a survey. DSP Guideline No. 3, Seismic Monitoring, provides guidance on seismic events that may trigger the need for surveys outside the routine annual monitoring.

In 2022, IRWD contracted with Genterra Consultants, Inc. (Genterra) to develop survey monitoring thresholds and action levels for San Joaquin Dam, Sand Canyon Dam, Rattlesnake Dam. The technical memoranda that Genterra prepared are listed as Reference 7.1 to 7.3. Syphon Dam was excluded from the analysis since at the time of conducting the analysis the reservoir was drained and planned to remain drained until Syphon Dam was completely replaced. GEI Consultants, Inc. (GEI) developed the thresholds and action levels for Santiago Creek Dam, which is listed as Reference 7.4. Table 2 below summarizes the alarms and responses for varying degrees of movement detected at the survey monuments.

Dam Safety Program Guideline No. 6 Movement Monitoring

Table 2: Alarm Levels and Response Plan for Survey Monuments for San Joaquin Dam, Sand Canyon Dam, Rattlesnake Dam, and Santiago Creek Dam

Status	Description	Response
Level I Green Alarm Normal	Observations and measurements from monitoring indicate expected and acceptable values. Vertical and horizontal displacements of survey monuments measured from the baseline should be within upper band value plus 0.35-inch and lower band value minus 0.35-inch.	<ul style="list-style-type: none"> • No immediate action required. • Continue routine inspection, monitoring, and maintenance program.
Level II Yellow Alarm Out of Range¹	Vertical and horizontal displacements of survey monuments measured from the baseline should be outside the limits of Green Alarm and within upper band value plus 0.6-inch and lower band value minus 0.6-inch.	<ul style="list-style-type: none"> • Review the data for reliability. Staff should take an additional two readings to confirm that the reading was initially taken is not an erroneous reading. • If additional readings confirm that the original reading is correct, then perform close visual inspection of the area that correlates with the reading. • Inform Dam Safety Engineer. • Determine if additional monitoring is required.
Level III Orange Alarm Increased Surveillance Alarm¹	Vertical and horizontal displacements of survey monuments measured from the baseline should be outside the limits of Yellow Alarm and within upper band value plus 6-inch and lower band value minus 6-inch.	<ul style="list-style-type: none"> • Staff should take additional readings to confirm that the reading was initially taken is not an erroneous reading. • If the additional readings confirm that the original reading is correct, then staff should start to perform an increased frequency of close visual inspections of the area and take more frequent readings to determine rate of increase or decrease, if any, for evaluation by the Dam Safety Engineer. • If work is occurring in affected area, direct all work to cease. • If the incremental movements of survey monuments between two surveys exceeds 1-inch, then IRWD should check for cracking and take measurements of cracks, including length and depth of cracking. • Inform parties involved with dam safety program if alarm level persists. • If needed, engage the involvement of Dam Engineering Consultant to confirm the severity. • Determine if a dam safety risk exists.

Dam Safety Program Guideline No. 6 Movement Monitoring

Table 2: Alarm Levels and Response Plan for Survey Monuments for San Joaquin Dam, Sand Canyon Dam, Rattlesnake Dam, and Santiago Creek Dam

Status	Description	Response
Level IV Red Alarm Immediate Action	Vertical and horizontal displacements of survey monuments measured from the baseline should be outside the limits of Orange Alarm.	<ul style="list-style-type: none"> • Staff should take additional readings to confirm that the reading was initially taken is not an erroneous reading. • If the additional readings confirm that the original reading is correct, then staff should start to perform daily close visual inspections of the area and take more frequent readings to determine rate of increase or decrease, if any, for evaluation by the Dam Safety Engineer. • If work is occurring in affected area, direct all work to cease. • If the incremental movements of survey monuments between two surveys exceeds 1-inch, then IRWD should check for cracking and take measurements of cracks, including length and depth of cracking. • Inform parties involved with dam safety program. • Engage the involvement of Dam Engineering Consultant to confirm the severity. • Determine if a dam safety risk exists. • Consider activating the Emergency Action Plan (EAP) if dam break or uncontrolled release of reservoir water is predicted by the Dam Safety Engineer or Dam Engineering Consultant. • Be ready to draw down the reservoir to reduce risk as directed by IRWD or DSOD.

¹GEI's Thresholds and Action Levels technical memorandum identifies a threshold of 0.36-inches and action level of 0.6-inches. As such, the Green Alarm and Red Alarm are used for Santiago Creek Dam and Yellow Alarm and Orange Alarm are excluded.

5.0 Responsibility

Engineering staff are responsible for monitoring movement at IRWD's dams. Table 3 summarizes the responsibilities.

Table 3: Movement Monitoring Responsibilities		
Description of Responsibility	Responsible Party	Notes
Manage surveying contract	Dam Safety Engineer	<ul style="list-style-type: none"> • Solicit Request for Proposals when necessary and retain services of licensed surveyor.
Review survey data	Dam Safety Engineer, Dam Engineering Consultant	<ul style="list-style-type: none"> • Compare survey data with historic readings. • Determine if readings are acceptable or if additional action is required.
Distribute survey data to Dam Engineering Consultant	Dam Safety Engineer	

6.0 Exhibits

- 6.1 GEI, “Location of Survey Monument Points for San Joaquin Dam”, September 2022.
- 6.2 GEI, “Location of Survey Monument Points for Sand Canyon Dam”, September 2022.
- 6.3 GEI, “Location of Survey Monument Points for Rattlesnake Dam”, September 2022.
- 6.4 GEI, “Location of Survey Monument Points for Santiago Creek Dam”, September 2022.
- 6.5 Guida, “Harding Dam Survey Control and Initial Values”, November 2023.

7.0 References

- 7.1 Genterra, “Technical Memorandum Identification of Instrumentation Thresholds and Action Levels at San Joaquin Dam”, January 13, 2023.
- 7.2 Genterra, “Technical Memorandum Identification of Instrumentation Thresholds and Action Levels at Sand Canyon Dam”, March 24, 2023.
- 7.3 Genterra, “Technical Memorandum Identification of Instrumentation Thresholds and Action Levels at Rattlesnake Dam”, March 22, 2023.
- 7.4 GEI, “Instrumentation Evaluation and Upgrade Recommendation”, October 31, 2022.

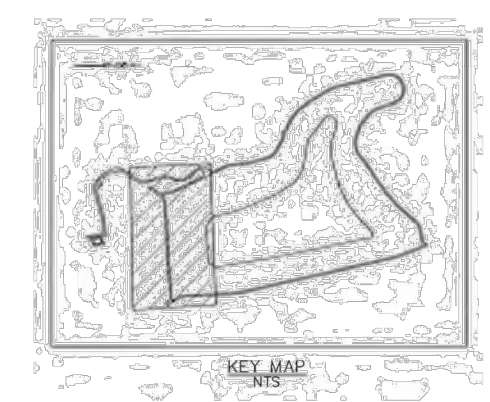
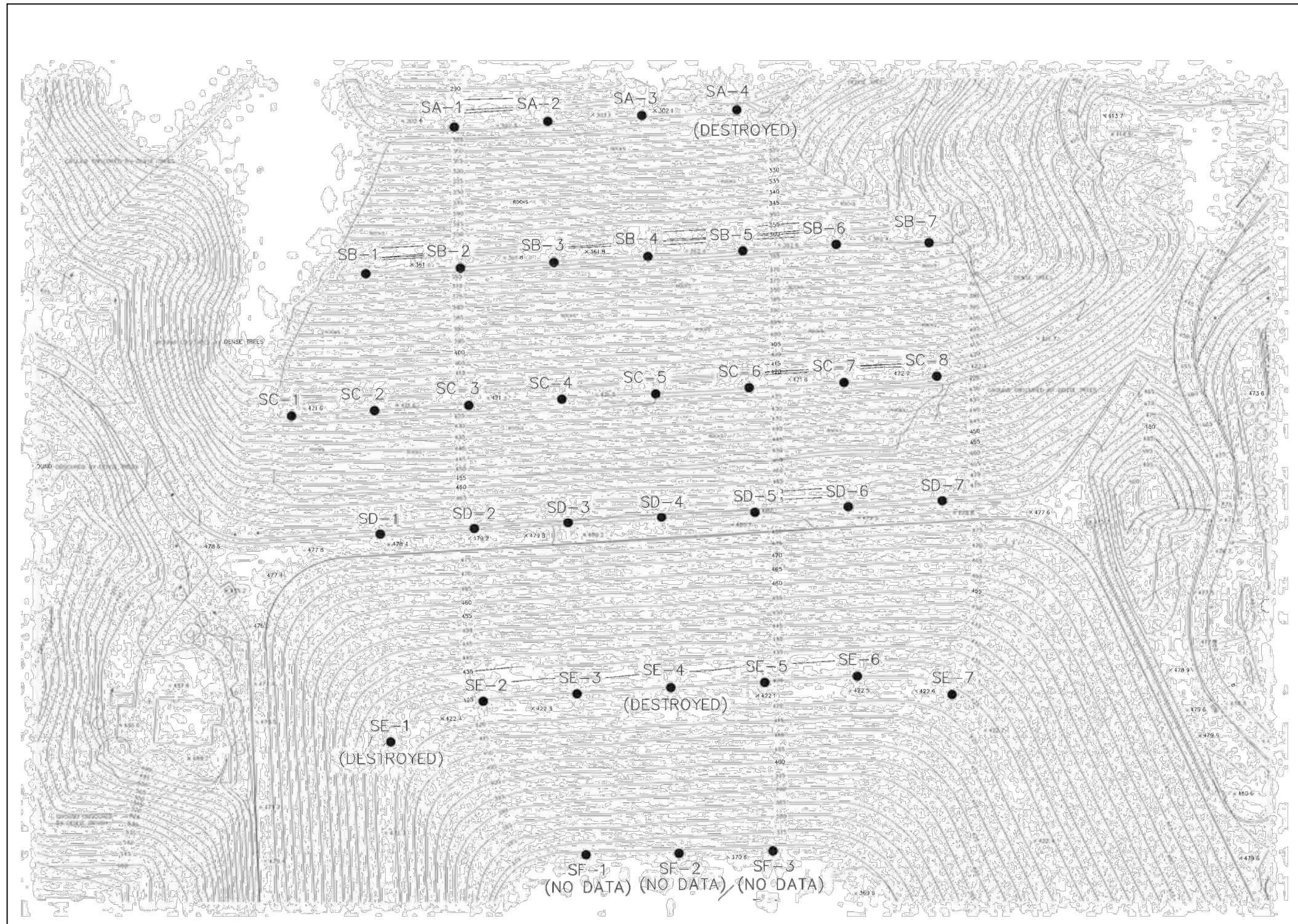

LEGEND

- SD-2 SURVEY MONUMENT

NOTES:

1. SF-1, SF-2 AND SF-3 SURVEY MONUMENTS ARE SUBMERGED UNDER WATER WHEN RESERVOIR WATER LEVEL IS ABOVE 371 FT.
2. SE-2, SE-3, SE-5, SE-6 AND SE-7 SURVEY MONUMENTS ARE SUBMERGED UNDER WATER WHEN RESERVOIR WATER LEVEL IS ABOVE 423 FT.

NOT TO SCALE

Annual Surveillance Report from Jan. 2021 to Dec. 2021
 San Joaquin Dam and Reservoir
 Irvine, CA
 Irvine Ranch Water District
 Irvine, CA



LOCATION OF SURVEY MONUMENT POINTS
 Project 1901888
 September 2022
 Fig. 6

Exhibit 6.1 - Location of Survey Monument Points for San Joaquin Dam

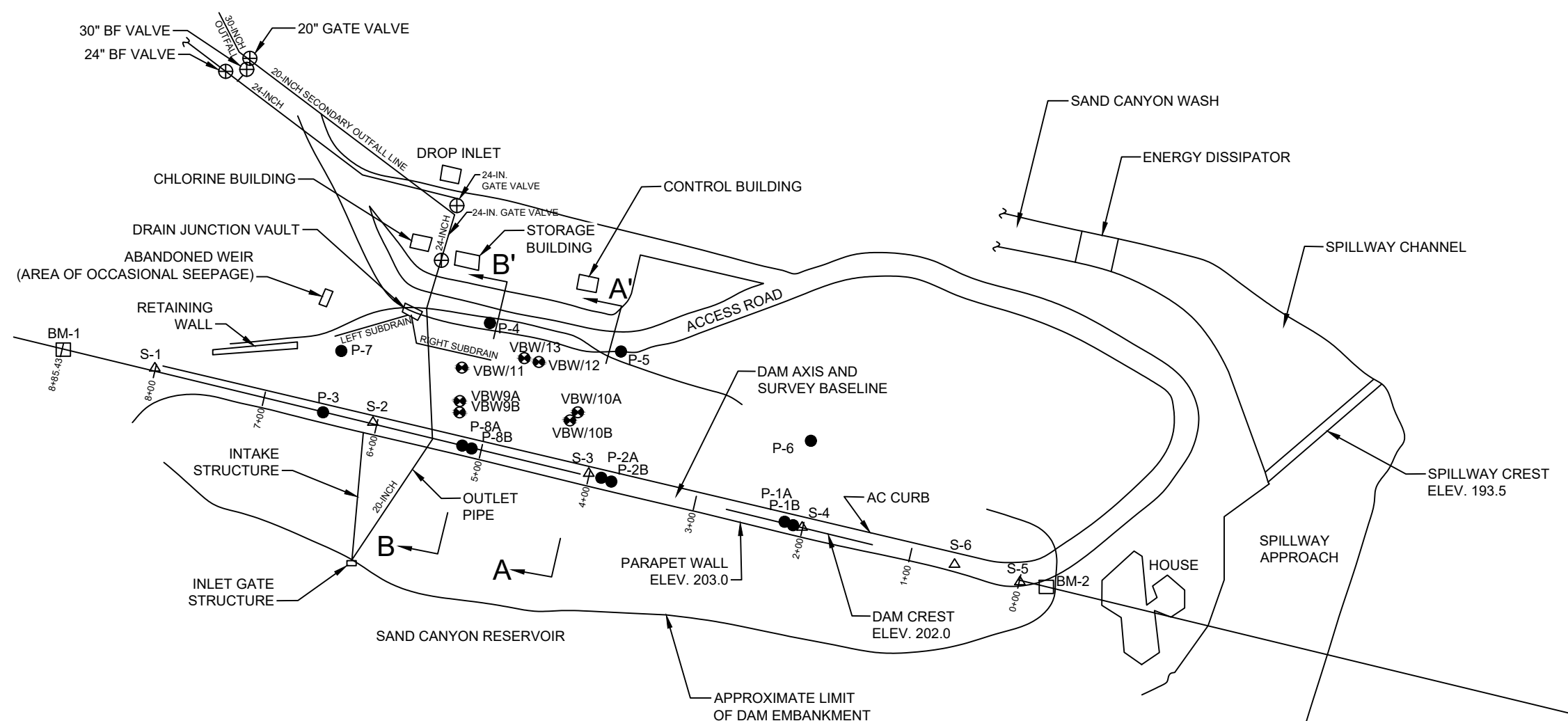

LEGEND

- ⊕ VBW/13 VIBRATING WIRE PIEZOMETER
- P-2A OPEN WELL PIEZOMETER
- △ S-3 SURVEY MONUMENT
- BM-1 BENCH MARK
- ↑ A ↑ A' LINE OF SECTION
- OUTLET PIPE
- SEEPAGE SUBDRAIN
- 0+00 STATION NUMBER

NOTES:

- (1) SECTION A-A' IS SHOWN ON FIGURE 2
- (2) SECTION B-B' IS SHOWN ON FIGURE 3
- (3) ELEVATIONS ARE IN FEET RELATIVE TO NGVD29 DATUM
- (4) LOCATIONS OF OUTLET PIPES AND VALVES ARE ESTIMATED

NOT TO SCALE

Annual Surveillance Report from Jan. 2021 to Dec. 2021 Sand Canyon Dam Irvine, CA		SITE AND INSTRUMENTATION PLAN	
Irvine Ranch Water District Irvine, CA		Project 1901888	September 2022

Fig. 1

Exhibit 6.2 - Location of Survey Monument Points for Sand Canyon Dam

LEGEND

- P-67 PIEZOMETER OR OBSERVATION WELL
- △ D SUBSURFACE SURVEY MONUMENT
- ⑧ FLOW POINT ID
- SEEPAGE VAULT
- BM-3 BENCH MARK
- ==== OUTLET PIPE
- ==== SUBDRAIN LINE
- +— STATION ALONG AXIS OF DAM
- A A' LINE OF SECTION

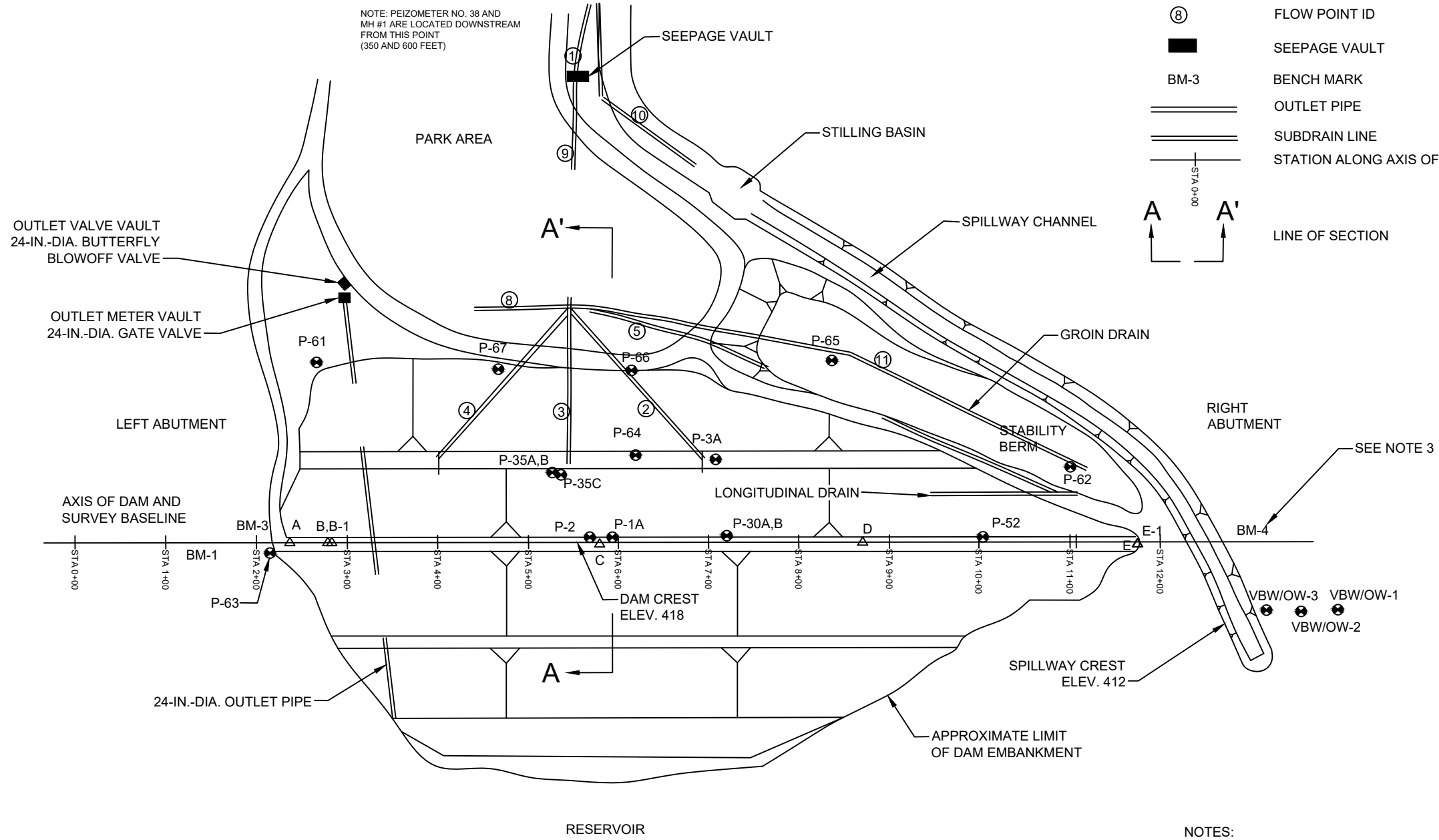
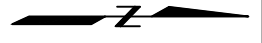

- NOTES:
1. SECTION A-A' SHOWN ON FIGURE 2
 2. ELEVATIONS ARE IN FEET RELATIVE TO NGVD29
 3. BM-4 WAS DESTROYED BETWEEN 2015 AND 2016. BM-4 WAS RE-ESTABLISHED BY 2018

NOT TO SCALE

Annual Surveillance Report from Jan. 2021 to Dec. 2021
 Rattlesnake Canyon Dam and Reservoir
 Irvine, CA
 Irvine Ranch Water District
 Irvine, CA



SITE AND INSTRUMENTATION PLAN
 Project 1901888
 September 2022
 Fig. 1

Exhibit 6.3 - Location of Survey Monument Points for Rattlesnake Dam

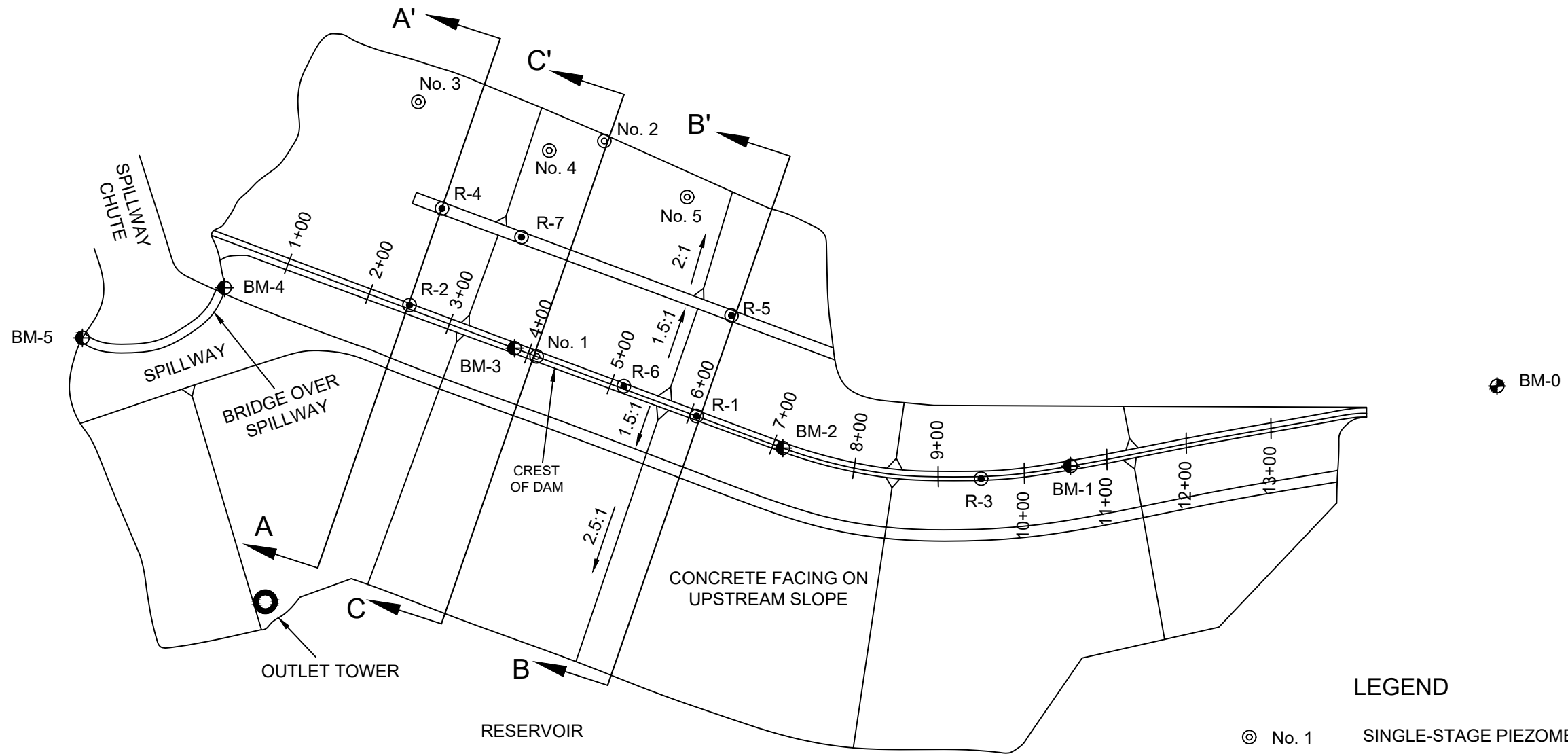

LEGEND

- ⊙ No. 1 SINGLE-STAGE PIEZOMETER
- ⊙ R-2 MULTI-STAGE PIEZOMETER
- ⊕ BM-5 SURVEY MONUMENTS
- ⊕ BM-0 BENCHMARK

NOTE: SECTIONS A-A', B-B' AND C-C' ARE SHOWN ON FIGURES 1B, 1C, AND 1D RESPECTIVELY.

NOT TO SCALE

Annual Surveillance Report from Jan. 2021 to Dec. 2021 Santiago Creek Dam Irvine, CA		SITE AND INSTRUMENTATION PLAN	
Irvine Ranch Water District Irvine, CA			Project 1901888

Exhibit 6.4 - Location of Survey Monument Points for Santiago Creek Dam

SURVEY CONTROL AND DATUM NOTES

1. COORDINATES ARE REFERENCED TO CCS83 ZONE 6 GRID, NAD83(2011) CSRS EPOCH 2017.50, EXPRESSED IN US SURVEY FEET.
2. ELEVATIONS ARE REFERENCED TO NAVD88, AS DERIVED FROM APPLYING THE NGS GEOID18 GEOID MODEL TO EPOCH 2017.50 ELLIPSOID HEIGHTS, EXPRESSED IN US SURVEY FEET.
3. HORIZONTAL AND VERTICAL DATUMS STATED ARE DEFINED LOCALLY BY THE CALIFORNIA SPATIAL REFERENCE SYSTEM. THIS SURVEY TIED TO CSRS STATIONS CNPP, MJPK, OEOC, AND WHYT, THE LATITUDE, LONGITUDE, AND ELLIPSOID HEIGHTS OF WHICH WERE HELD FIXED IN A LEAST SQUARES ADJUSTMENT. THE LATITUDE, LONGITUDE, AND ELLIPSOID HEIGHTS OF THE CSRS STATIONS WERE OBTAINED FROM THE CSRS EPOCH 2017.50 DATA TABLE 1, VERSION 5.
4. THE SURVEY WAS PERFORMED AS A SECOND ORDER HORIZONTAL GPS SURVEY ACCORDING TO SPECIFICATIONS GIVEN IN CALTRANS SURVEY MANUAL, CHAPTERS 5, 6, AND 9, USING TRIMBLE R10 AND R12 RECEIVERS. THE OBSERVED DATA WAS POST PROCESSED USING TBC V5.8 SOFTWARE, AND THE RESULTANT VECTORS WERE ADJUSTED USING STAR*NET V11 SOFTWARE.
5. INITIAL VALUES OF DAM MONITOR POINTS DETERMINED IN A STATIC GNSS SURVEY PERFORMED ON NOVEMBER 29TH AND 30TH, 2023.

DAM MONITOR POINTS – INITIAL VALUES

HORZ: CCS83 ZONE 6, NAD83(2011) CSRS EPOCH 2017.50, USSF
 VERT: NAVD88 + GEOID 18, USSF

POINT	NORTH	EAST	ELEVATION	DESC
S1	2206366.331	6143895.419	1425.07	SET 2" BRASS DISK
S2	2206383.208	6143890.455	1424.97	SET 2" BRASS DISK
S3	2206421.009	6143867.330	1425.23	SET 2" BRASS DISK

SURVEYOR'S STATEMENT

THIS EXHIBIT HAS BEEN PREPARED BY ME, OR UNDER MY DIRECTION, IN CONFORMANCE WITH THE PROFESSIONAL LAND SURVEYORS ACT AT THE REQUEST OF THE IRVINE RANCH WATER DISTRICT IN NOVEMBER 2023.

 MARK S PETRIE, PLS 6902 12-04-2023 DATE

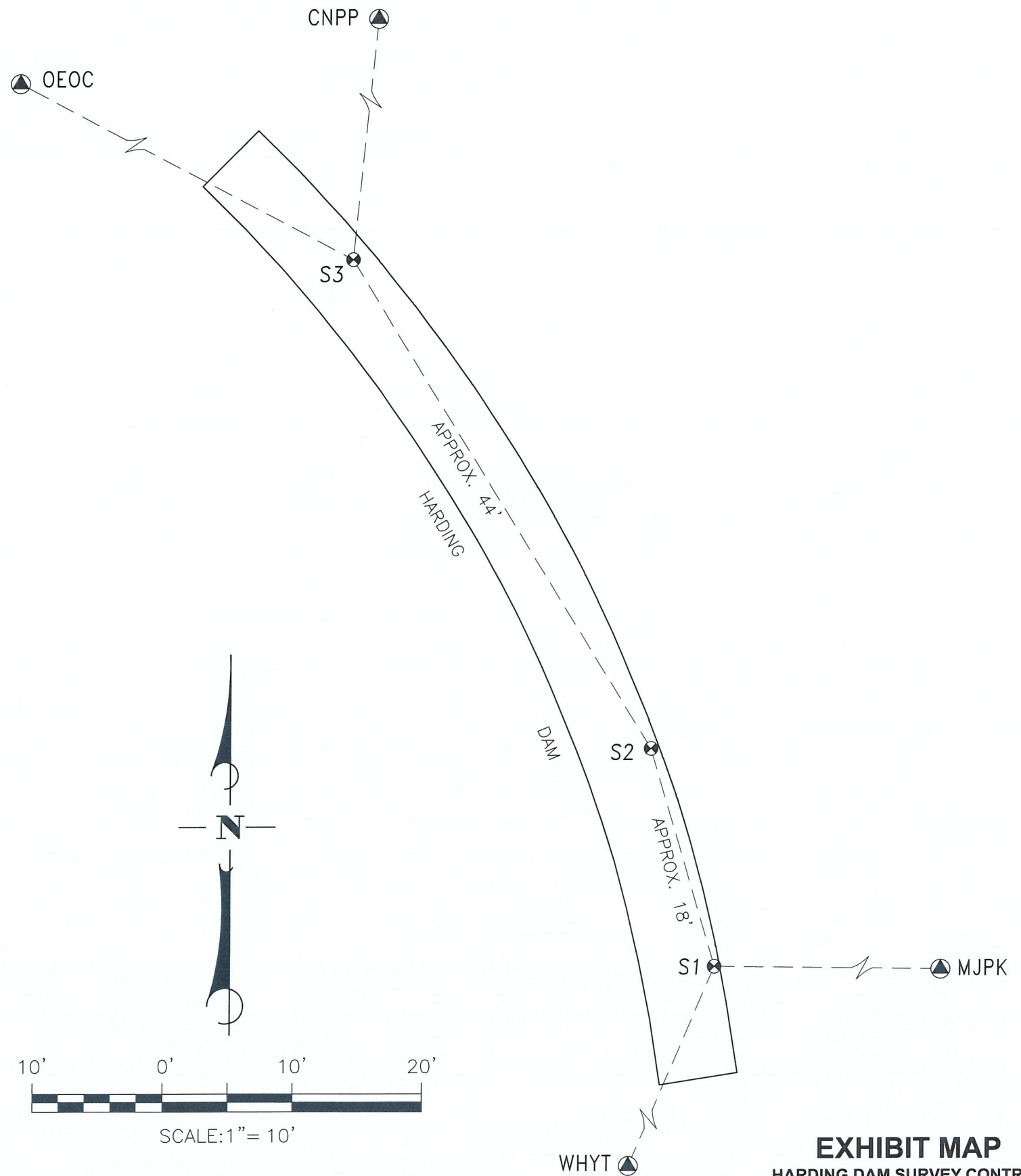

Exhibit 6.5 - Location of Survey Monument Points for Harding Canyon Dam

EXHIBIT MAP
 HARDING DAM SURVEY CONTROL
 AND INITIAL VALUES
 NOVEMBER 2023

1.0 Purpose

The purpose of this document is to provide guidance for mechanical, electrical, reservoir liner, and access road maintenance at Irvine Ranch Water District’s (IRWD) dams.

2.0 Definitions

Below is a summary of terms used herein that are related to IRWD’s Dam Safety Program (DSP).

Critical Valve - The valve located on the downstream of the dam that releases water from the reservoir to a creek, stream, or storm drain system. The critical valve is sometimes referred to as blowoff valve.

Inlet Outlet Valve - valves located on the outlet pipeline that allow water to enter the outlet pipeline from the reservoir.

3.0 Background

3.1 Outfall Maintenance

IRWD’s dams include outlet works facilities that allow discharges to downstream water conveyance facilities. In the event of an emergency or to manage the water level in the reservoir in anticipation of upcoming storm events, water can be released to downstream conveyance systems by operating the critical valve. Section 6102.5 (c) of the California Water Code requires that the critical valve demonstrate its full operability annually and in the presence of DSOD every three years. Table 1 below summarizes the discharge configurations to downstream creeks and the capacities. The estimated maximum flow rates, unless otherwise noted, are rough estimates based on a full reservoir and do not reflect output from computer based hydraulic modeling.

Dam	Description	Estimated Max Flow Rate (cfs) ⁵	Water Source
San Joaquin	60-inch outlet conduit near right upstream groin toe area with a 18-inch blowoff butterfly valve. Blowoff valve drains into the east storm drain.	50	Recycled Water
Sand Canyon	20-inch outlet pipe under the dam connects to a 24-inch blowoff butterfly valve that discharges to the Sand Canyon Wash.	57 ¹	Recycled Water
Syphon	36-inch outlet conduit through the embankment that connects to a 36-inch blowoff plunger valve that discharges to storm drain.	-- ²	Recycled Water
Rattlesnake	24-inch outlet conduit through the embankment that connects to a 24-inch blowoff butterfly valve that discharges to the access road, which is tributary to Rattlesnake Creek.	120	Recycled Water

Santiago Creek	60-inch outlet conduit through the embankment that connects to a 30-inch blowoff cone valve that discharges to the Santiago Creek.	250 ³	Untreated Water ⁴
Harding Canyon	16-inch outlet pipe through base of concrete dam with a 16-inch butterfly valve. Blowoff valve discharges to downstream creek.	20	Native Runoff

¹Flow rate based on “Emergency Dewatering Program – Sand Canyon, Rattlesnake, Irvine Lake & San Joaquin Reservoirs” dated November 1, 1976.

²Existing capacity is unknown. Future capacity of 226 cfs per the Syphon Reservoir Improvement Project Preliminary Design Report.

³Value represents existing capacity based on full reservoir. The future capacity is 600 cfs based on a full reservoir per Santiago Creek Dam Outlet Tower and Spillway Improvements Preliminary Design Report.

⁴Untreated water is a blend of native runoff and imported untreated water from Metropolitan Water District of Southern California.

⁵Values assume full reservoir.

In accordance with Order No. R8-2015-0024 (NPDES No. CA8000326) IRWD is permitted to discharge water from its dams when DSOD requires it for “dam safety or other reasons”.

4.0 General Guidelines

4.1 Critical Valve

Section 6102.5, Subsection (c) of the California Water Code requires that dam owners operate the critical outlet control features on an annual basis to demonstrate its full operability. The section also requires that the full operability be demonstrated in the presence of Division of Safety of Dams (DSOD) every three years. To comply with this state law, IRWD will operate the critical valve at each of its dams and release water to demonstrate the operability on an annual basis. The Operations department will schedule and record the testing. The location of the critical valves are shown in Exhibits 6.1 to 6.6.

4.2 Water Quality Management System

Most of IRWD’s dams have aeration or sonic systems to help manage water quality. Table 2 below summarizes the water quality management systems at each dam. IRWD performs maintenance on the aeration system on an as-needed basis. When Operations staff notice that the aeration system is not functioning properly, Mechanical Maintenance staff are contacted to investigate and perform maintenance. Maintenance and operation of the sonic system is contracted out to a third party.

Table 2: Summary of Water Quality Management Systems		
Dam	Description	Notes
San Joaquin	LG Sonic System	<ul style="list-style-type: none"> Mechanical Maintenance maintains the third-party contract. The third party controls the sonic frequency system for algae control. Mechanical Maintenance routinely cleans the solar powered system.

		<ul style="list-style-type: none"> Water Operations logs into LG Sonic only portal weekly to check operating status and water quality of reservoir (e.g., temperature, dissolved oxygen (DO), pH, algae count, etc) Electrical Maintenance replaces the pH and DO probes. Manufacturer recommends pH probe be replaced annually and DO probe replaced every two years.
Sand Canyon	Pneumatic aeration system	Mechanical Services maintains compressors and aerators
Syphon	Pneumatic aeration system	Offline – Mechanical service maintains compressor and aerators
Rattlesnake	Solar bees	Electrical Service maintains service contract
Santiago Creek	Pneumatic aeration system	Serrano Water District maintains system
Harding Canyon	None	

The aeration system is not critical to dam safety, however maintaining water quality is important in part because it can contribute to fouling the intake screens and outlet pipe, which could then become a dam safety concern.

4.3 Inlet Outlet Valves

The inlet outlet valves located on the outlet pipe in the reservoir are an important component of the dam. Reliable operation of the valves helps ensure that the maximum amount of water can enter the outlet pipe and be released from the reservoir in the event of an emergency or as part of IRWD’s reservoir management. Table 3 below summarizes the inlet outlet valves and critical valves at each dam.

Dam	Valve Description	Elev. (ft)	Notes
San Joaquin	48-inch butterfly valve	443	<ul style="list-style-type: none"> Mechanical Maintenance will periodically check the hydraulic fluid level for the electro-hydraulic actuators and refill as necessary. If hydraulic fluid is noticed in the reservoir, Mechanical Maintenance is contacted for service.
	48-inch butterfly valve	408	
	48-inch butterfly valve	373	
	24-inch butterfly valve	362	
	18-inch butterfly valve (Critical Valve)	277	Bottom drain on 60-inch outlet to 48-inch storm drain

**Dam Safety Program
Guideline No. 7
Maintenance**

Sand Canyon	24-inch gate valve	185	<ul style="list-style-type: none"> The critical valve to the creek is in the stream bed and requires periodic clearing. IRWD's Landscape Manager periodically clears the area as part of vegetation management plan Occasionally the blowoff to creek can be filled with silt, especially when the spillway is used. The blowoff to creek should be inspected after each spillway usage. Several valves between the critical valve and the outlet valves must be open to release water to the creek. See Exhibit 6.2 for quantity and location of valves.
	24-inch gate valve	177	
	24-inch gate valve	170	
	24-inch butterfly valve (Critical Valve)		
Syphon	<i>TBD</i>		
Rattlesnake	30-inch butterfly valve	390	Upper screen in reservoir
	30-inch butterfly valve	384	Middle screen in reservoir
	30-inch butterfly valve	375	Lower screen in reservoir
	24-inch butterfly valve	369	Main valve in reservoir
	30-inch butterfly valve	347	Flow meter isolation valve
	24-inch butterfly valve	346	On discharge line to access road
	24-inch butterfly valve (Critical Valve)	349	The critical valve discharges to the gravel access road.
Santiago Creek	24-inch gate valve	750	
	24-inch gate valve	740	
	24-inch gate valve	730	
	24-inch gate valve	720	Snorkel extension with intake to 735-ft
	30-inch gate valve	710	Under silt line
	30-inch gate valve	700	Under silt line

	30-inch gate valve	690	Under silt line
	30-inch gate valve	680	Under silt line
Harding Canyon	16-inch butterfly valve	--	Blind flange installed
	6-inch gate valve	--	Off pipeline to Manning Water Treatment Plant

¹Valves are listed in descending order with the first valve located farthest away from the outlet.

4.4 Electrical Maintenance

Generally, IRWD’s electrical team does not perform routine maintenance at IRWD’s dams. As needed, staff will contact the Electrical Maintenance team for support with electrical equipment including, but not limited to, programmable logic controls (PLCs), electrical panels, piezometers, level instruments, switchgears, and other electrical related appurtenances.

Electrical Services manages the SolarBee maintenance contract for all of IRWD’s solar powered aerations systems, including the two located in Rattlesnake Reservoir. The maintenance contract includes an annual onsite inspection that includes complete inspection of mechanical, structural, and electronic equipment, and adjustments to the equipment.

Electrical Services also annually services the San Joaquin seepage return pump station located near the toe of the dam. The seepage return pump station includes the following electrical equipment that is annually inspected and maintained.

- Radar instruments for measuring water level in seepage weir box
- Submersible pumps and level instruments in pump station that conveys seepage flow back to the reservoir (e.g., backwash return pump station at San Joaquin Dam)
- Flow meters that monitor pumping flow rates
- PLC for the pump station and that displays seepage flow rate in weir box
- Instruments for LG Sonic System at San Joaquin Dam

In addition to the above annually inspected items, Electrical Services also maintains the level monitoring system located near the Sand Canyon Spillway.

4.5 Liner Maintenance

Liners serve an important role at IRWD’s dams. The primary purpose of liners at IRWD’s dams is to protect the reservoir and dam from erosion from runoff or wave action. Maintenance of the liners along the perimeter of the reservoir helps ensure protection of the slopes. Liners along the upstream side of the dam protect the condition of the dam. Table 4 below summarizes the dams and reservoirs with liners.

Table 4: Summary of Dam and Reservoir Liners		
Dam	Description	Notes
San Joaquin	AC liner on upstream side of dam and around the perimeter of the reservoir	Last liner repairs completed in 2024.
Sand Canyon	AC liner on upstream side of dam	Last liner repairs completed in 2024.
Syphon	None (rock on upstream side of dam)	
Rattlesnake	AC liner on upstream side of dam	Last liner repairs completed in 2023.
Santiago Creek	Concrete on upstream side of dam	
Harding Canyon	None	

The liners require continuous maintenance to protect the embankment or reservoir from erosion and to minimize the further degradation of liner material. As part of the Annual Surveillance and Monitoring program, IRWD and the consultant contracted for the Annual Surveillance Program will review the condition of the liners and identify areas that require maintenance. Upon completion of the Annual Surveillance Report, the Water Operations staff will itemize the areas that require repair. The Dam Safety Engineer will ensure service requests are entered for maintenance related items. In cases where repairs are identified that require a comprehensive review and design that is beyond the maintenance team’s capabilities, the Dam Safety Engineer will log the item and propose the item as a project in future budget cycles or coordinate the completing of the work with other engineering resources.

5.0 Responsibility

Multiple departments have responsibility for maintaining the mechanical and electrical equipment and general condition at IRWD’s dams. Table 5 below summarizes the activities and corresponding responsible party.

Table 5: Summary of Activities and Responsibilities Related to Maintenance			
Description of Activity	Responsible Party	Frequency	Notes
Exercise inlet outlet valves	Water Operations	Annually	Exercise may or may not include flowing water.
Exercise and operate critical valve to demonstrate operability	Water Operations	Annually	Exercise and operation include physically flowing water downstream.
Piezometer troubleshooting, maintenance, and replacement	Water Operations and Electrical Maintenance	As needed	Water Operations conducts initial troubleshooting when readings appear incorrect.
Piezometer cleaning	Electrical Maintenance	As needed	Dam Safety Engineer or Water Operations may identify piezometers that require cleaning based on review of piezometer readings.

Dam Safety Program Guideline No. 7 Maintenance

Identify liner restoration needs	Dam Safety Engineer , Water Operations	Annually	<ul style="list-style-type: none"> • Dam Safety Engineer manages Annual Surveillance Program that may identify areas in need of restoration. • Water Operations will itemize the areas for Construction Services.
Coordinate and complete liner restoration	Construction Services	As needed	Construction Services manages repairs.
Notification to DSOD of Maintenance Activities	Dam Safety Engineer	As needed	
Maintenance of Aeration and LG Sonic System	Water Operations, Electrical Maintenance, Mechanical Maintenance		See Table 2 for a description of responsibilities.
Report discharge volumes and advance notification of event to Regulatory Compliance	Water Operations	As needed	

6.0 Exhibits

- 6.1 Location of Critical Valve at San Joaquin Dam
- 6.2 Location of Critical Valve at Sand Canyon Dam
- 6.3 Location of Critical Valve at Syphon Dam
- 6.4 Location of Critical Valve at Rattlesnake Dam
- 6.5 Location of Critical Valve at Santiago Creek Dam
- 6.6 Location of Critical Valve at Harding Canyon Dam

7.0 References

- 7.1 California Regional Water Quality Control Board, Santa Ana Region, Order R8-2015-0024, NPDES No. CA8000326
- 7.2 California Constitution, Water Code, Division 3 Dams and Reservoirs, Part 1 Supervision of Dams and Reservoirs, Chapter 4 Powers of the Department, Article 2 Maintenance and Operation, Section 6102.5

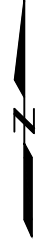
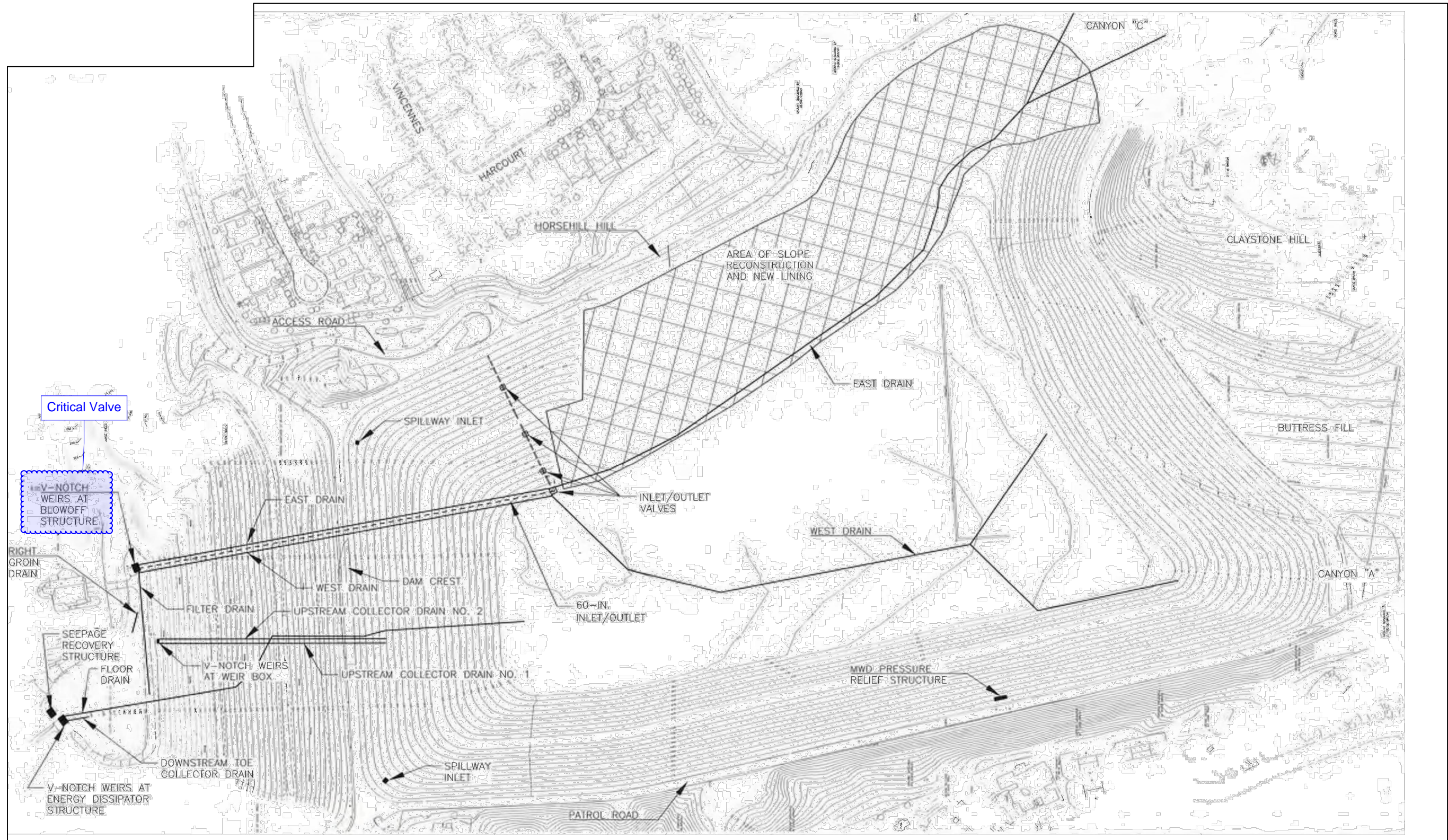

NOT TO SCALE

Annual Surveillance Report from Jan. 2021 to Dec. 2021
 San Joaquin Dam and Reservoir
 Irvine, CA
 Irvine Ranch Water District
 Irvine, CA

GEI Consultants
 Project 1901888

DAM AND RESERVOIR SITE PLAN

August 2022

Fig. 2

Exhibit 6.1
 Location of Critical Valve at San Joaquin Dam

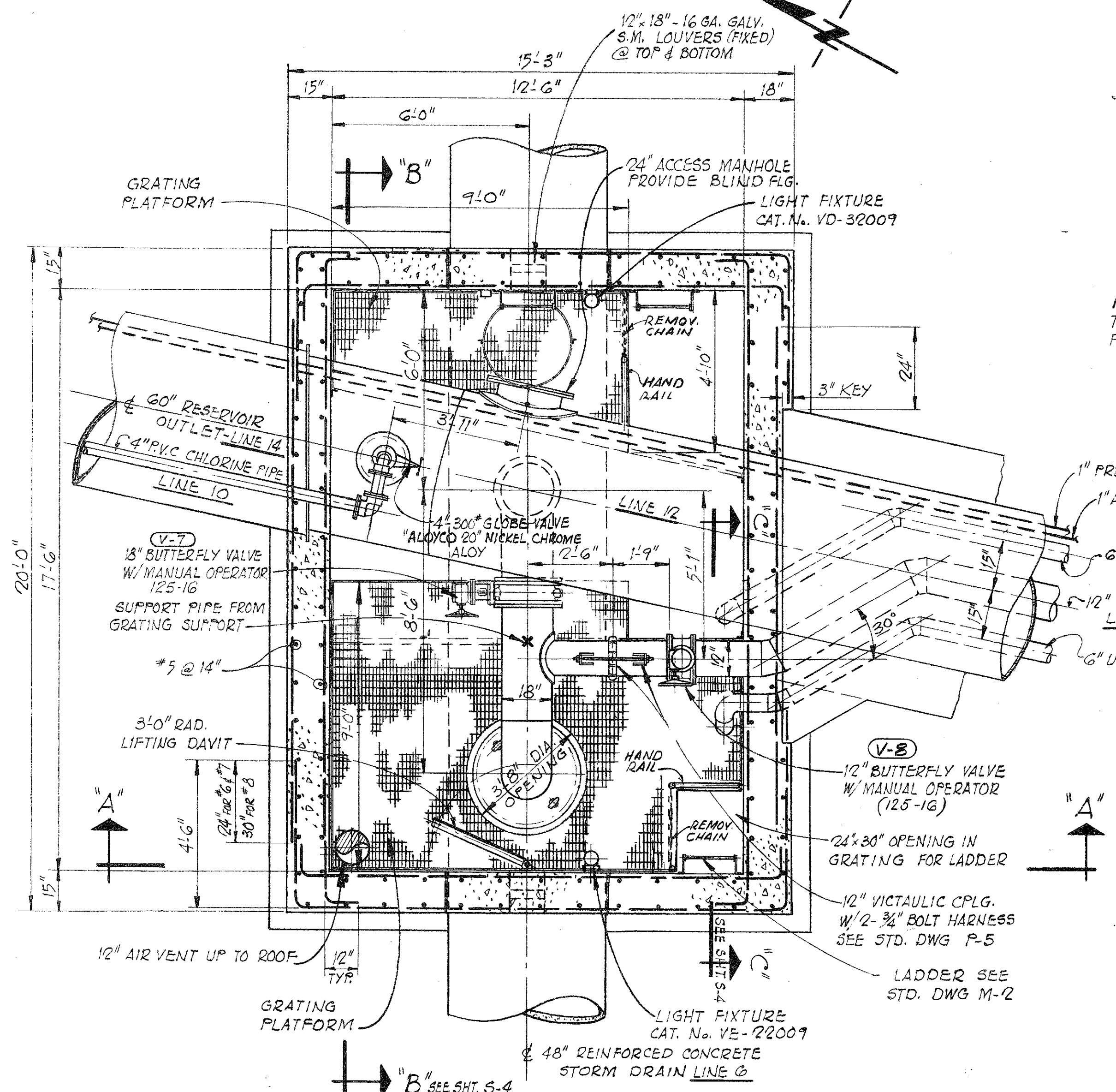

SECTIONAL PLAN VIEW
SCALE: 3/8" = 1'-0"

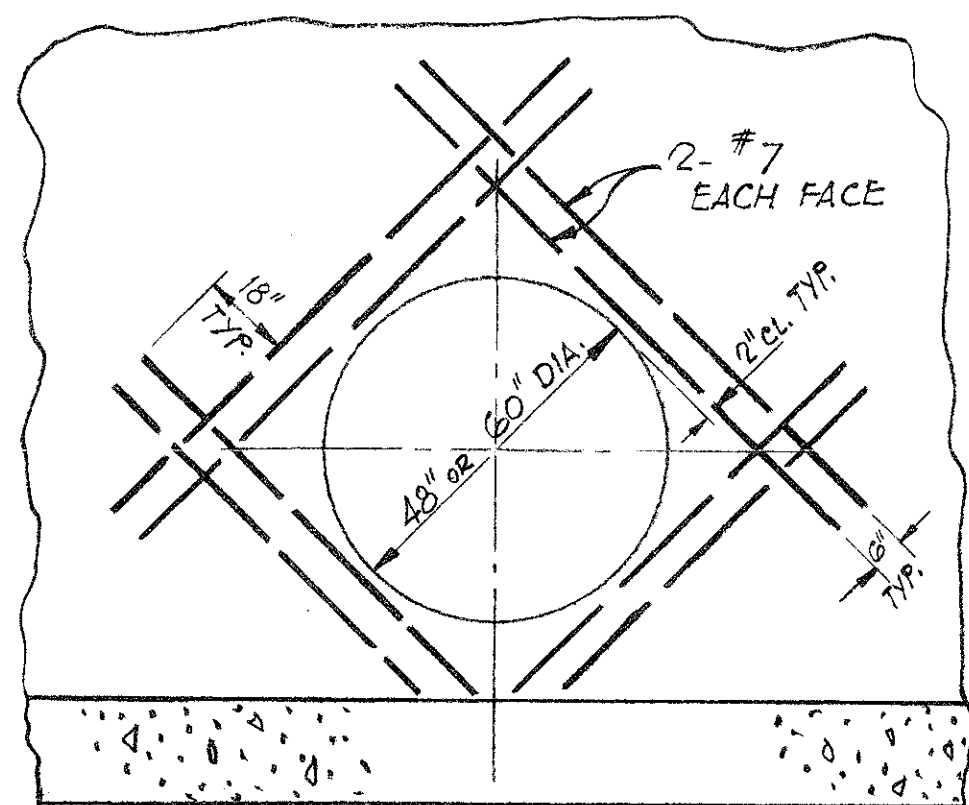

TYPICAL DETAIL FOR PIPE OPENING
SCALE: 3/8" = 1'-0"

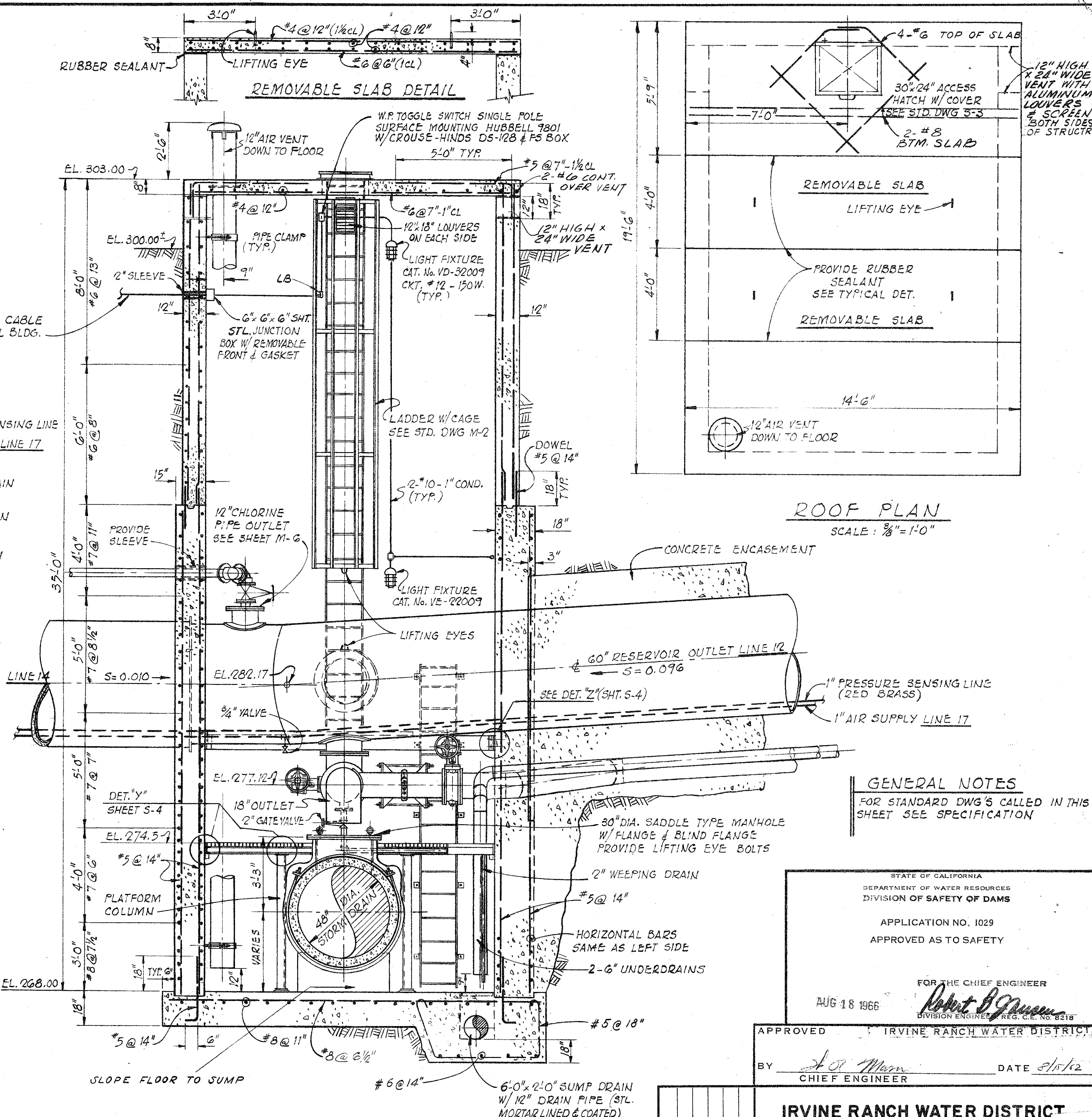

SECTION A-A
SCALE: 3/8" = 1'-0"

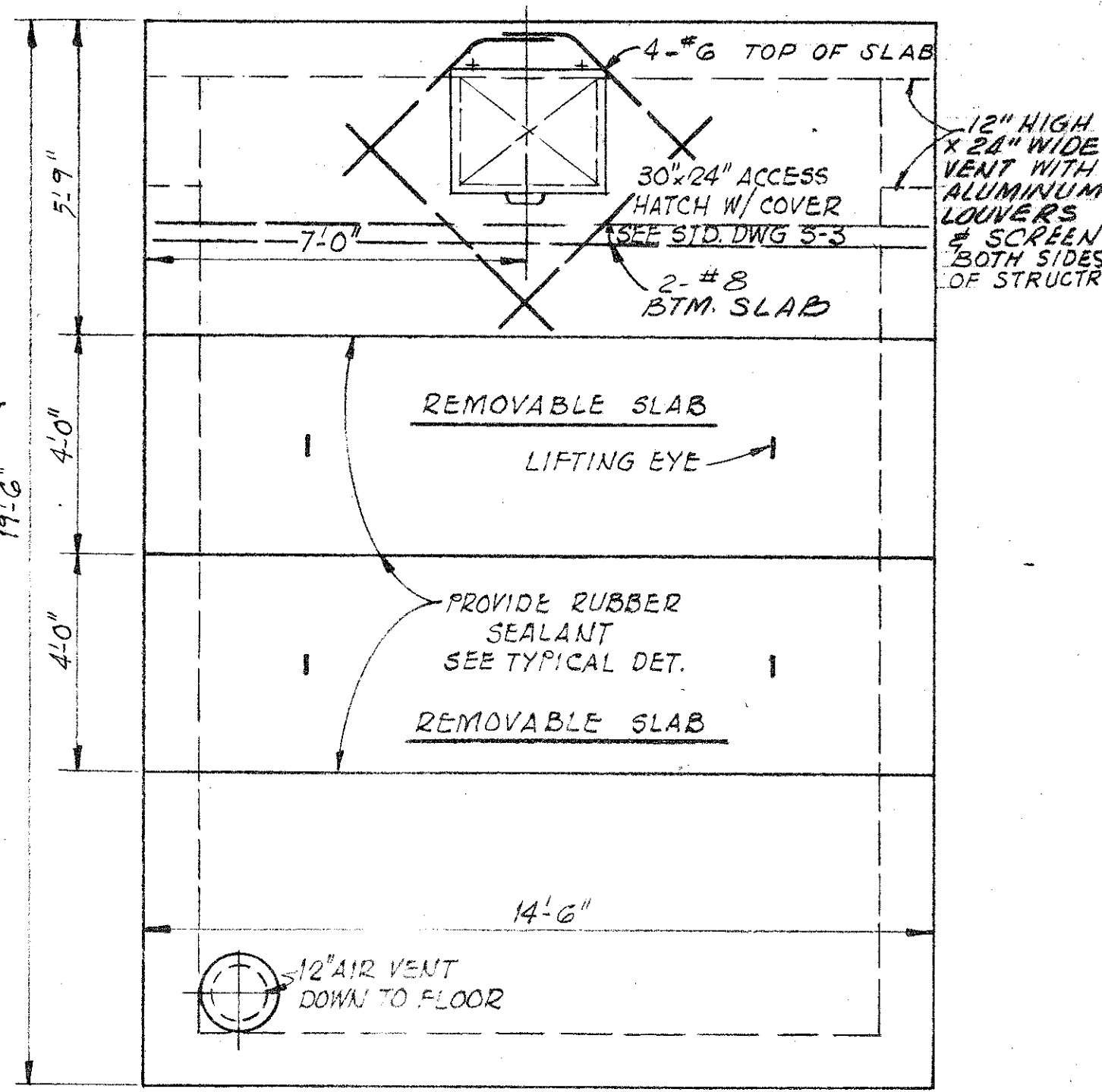

ROOF PLAN
SCALE: 3/8" = 1'-0"

GENERAL NOTES
FOR STANDARD DWG'S CALLED IN THIS SHEET SEE SPECIFICATION

STATE OF CALIFORNIA
DEPARTMENT OF WATER RESOURCES
DIVISION OF SAFETY OF DAMS
APPLICATION NO. 1029
APPROVED AS TO SAFETY
AUG 18 1966
FOR THE CHIEF ENGINEER
Robert B. Gorman
DIVISION ENGINEER REG. C.E. NO. 8218

APPROVED BY *J. J. Mann* CHIEF ENGINEER DATE 8/18/66

IRVINE RANCH WATER DISTRICT	
SAN JOAQUIN RESERVOIR	
BLOWOFF STRUCTURE PLAN AND SECTIONS	
DESIGNED BY <i>P.R.</i>	SCALE: AS SHOWN
JAMES M. MONTGOMERY CONSULTING ENGINEERS, INC. 535 E. WALNUT STREET, PASADENA, CALIFORNIA MURRAY 1-5619 SYCAMORE 3-7128	
DATE: <i>Aug 15 1966</i>	SHEET: S-3 OF 6 SHEETS

AS BUILT DRAWING

EAST FILE CORP. IRVINE, CA 1602 EIR-24

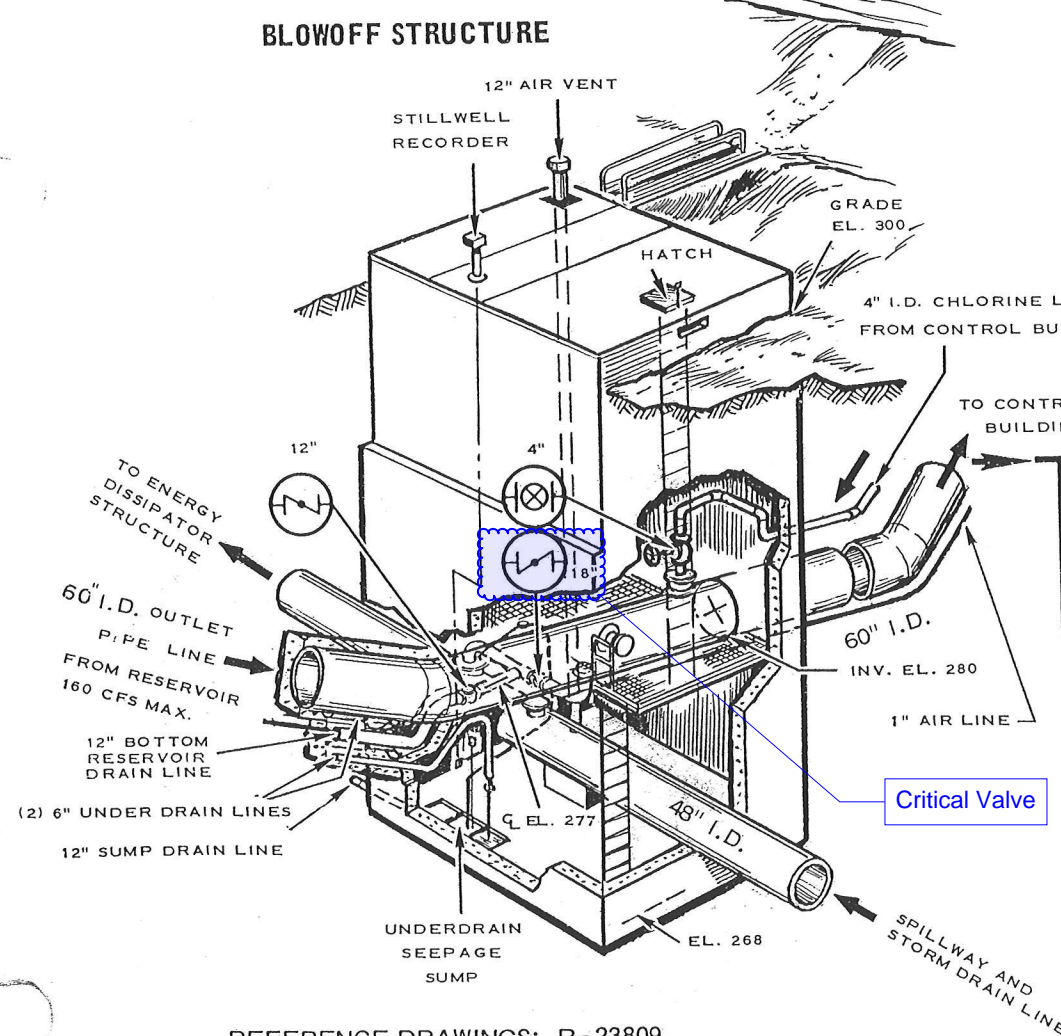
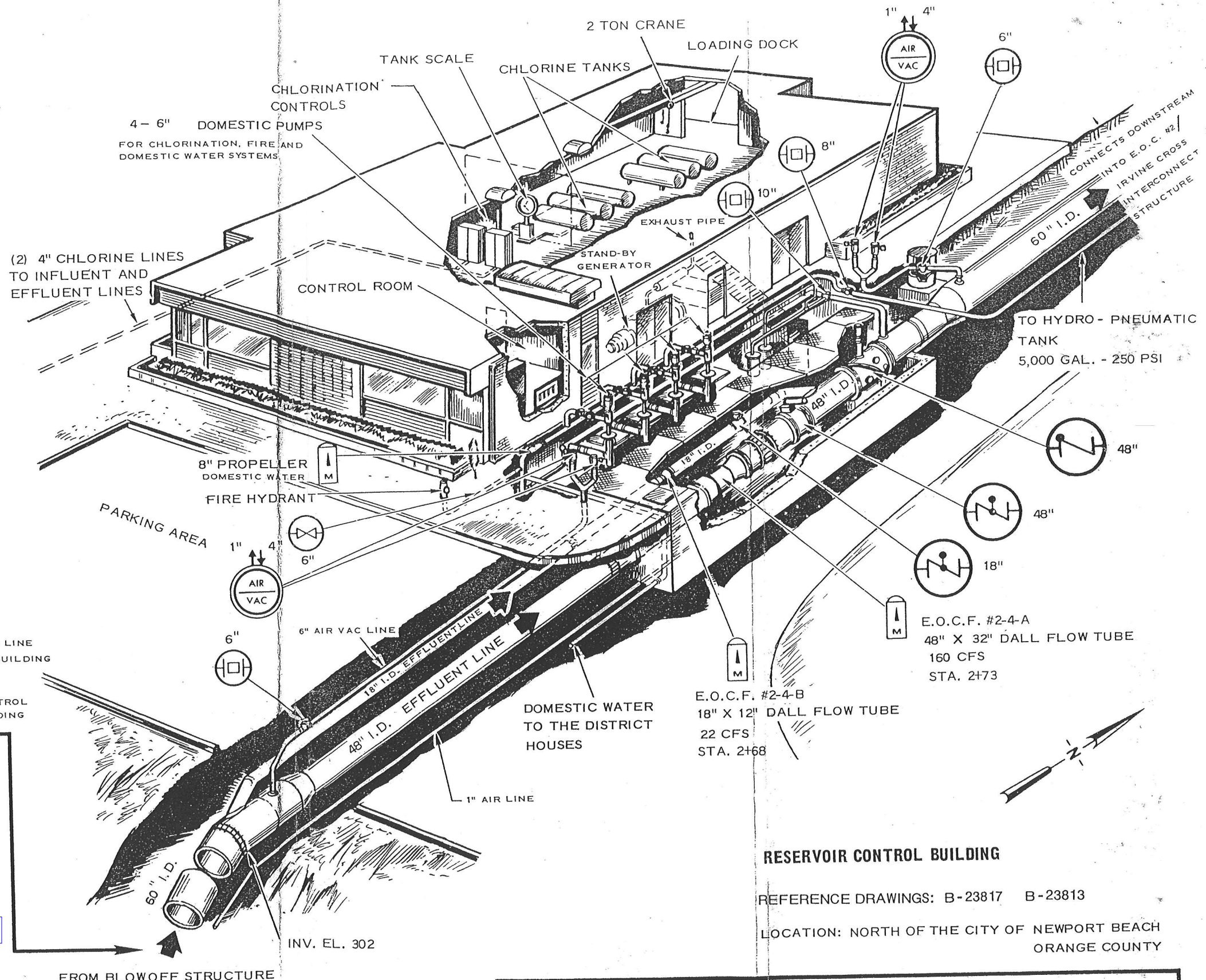
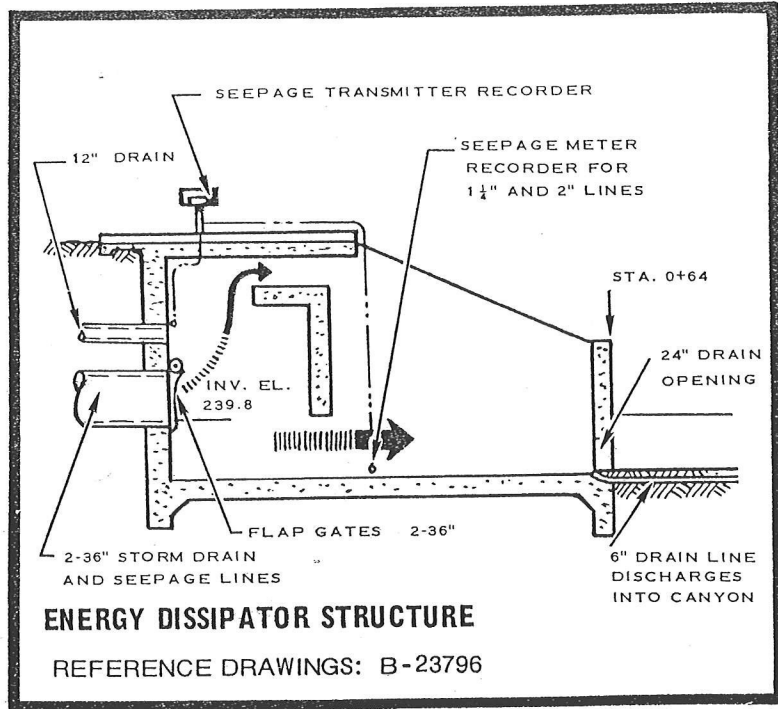

RESERVOIR CONTROL BUILDING

REFERENCE DRAWINGS: B-23817 B-23813

LOCATION: NORTH OF THE CITY OF NEWPORT BEACH ORANGE COUNTY

SAN JOAQUIN RESERVOIR

REFERENCE DRAWINGS: B-23809

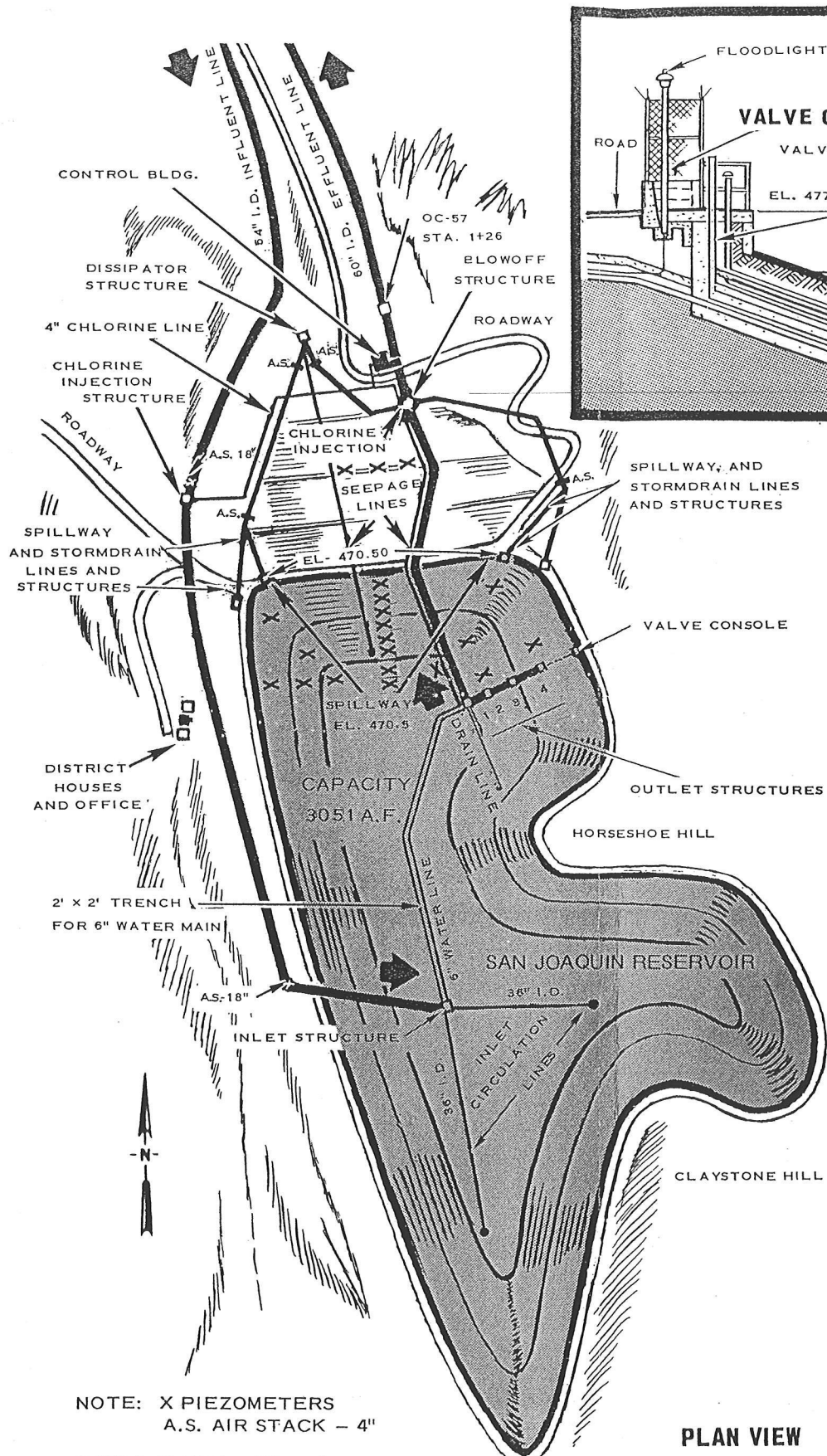

NOTE: X PIEZOMETERS
A.S. AIR STACK - 4"

REFERENCE DRAWINGS:
 JAMES M. MONTGOMERY SPECIFICATIONS B-23763 B-23771
 SAN JOAQUIN RESERVOIR - R.C.E. NO. 5677 B-23807
 MWD RESOLUTION 6065 DATED 3-13-1962 B-23815 B-23816

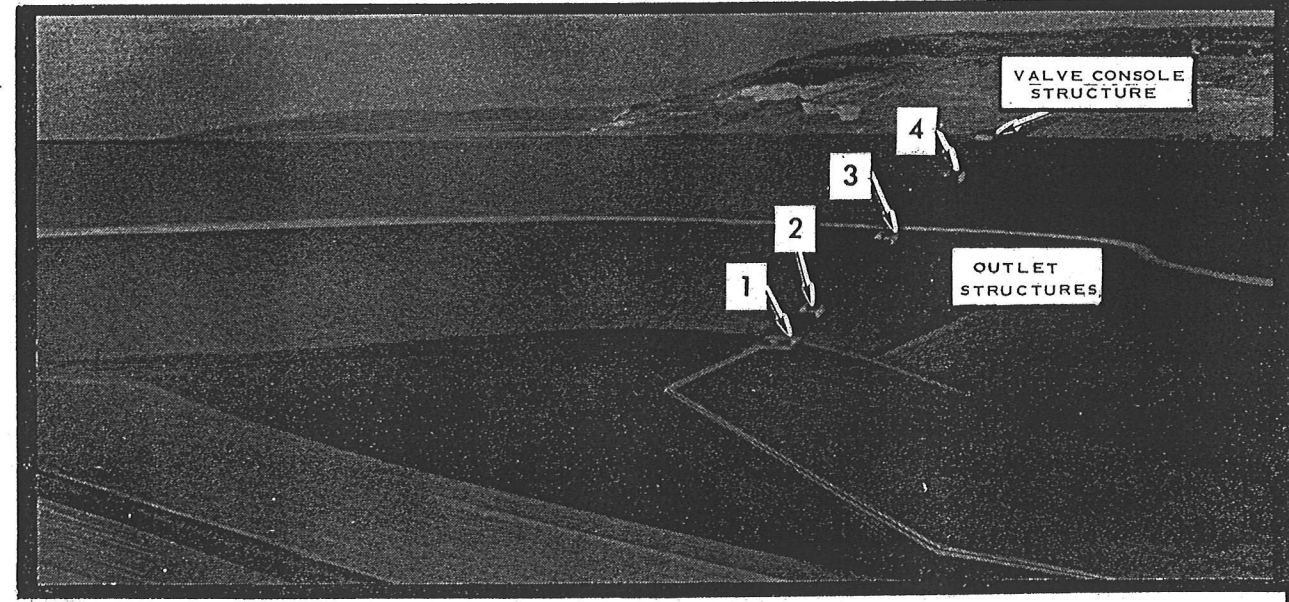
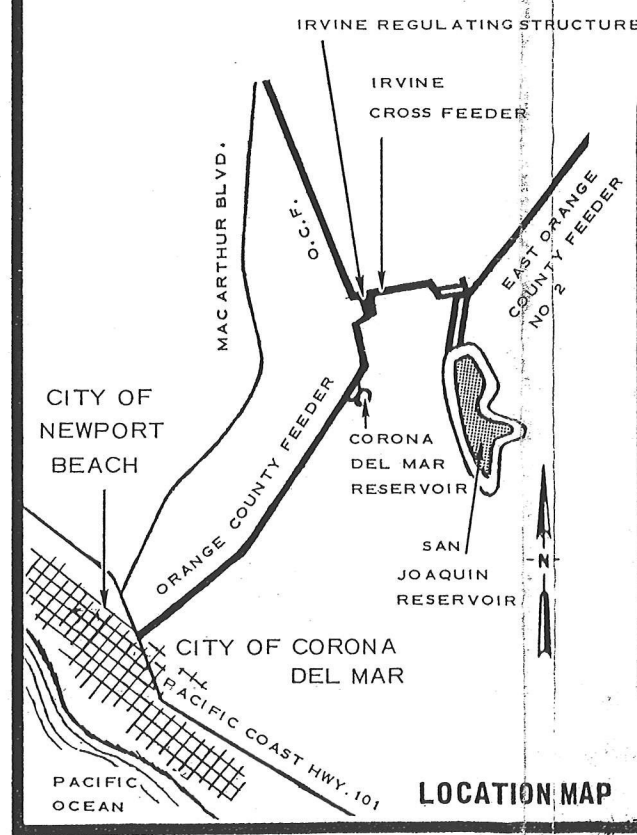
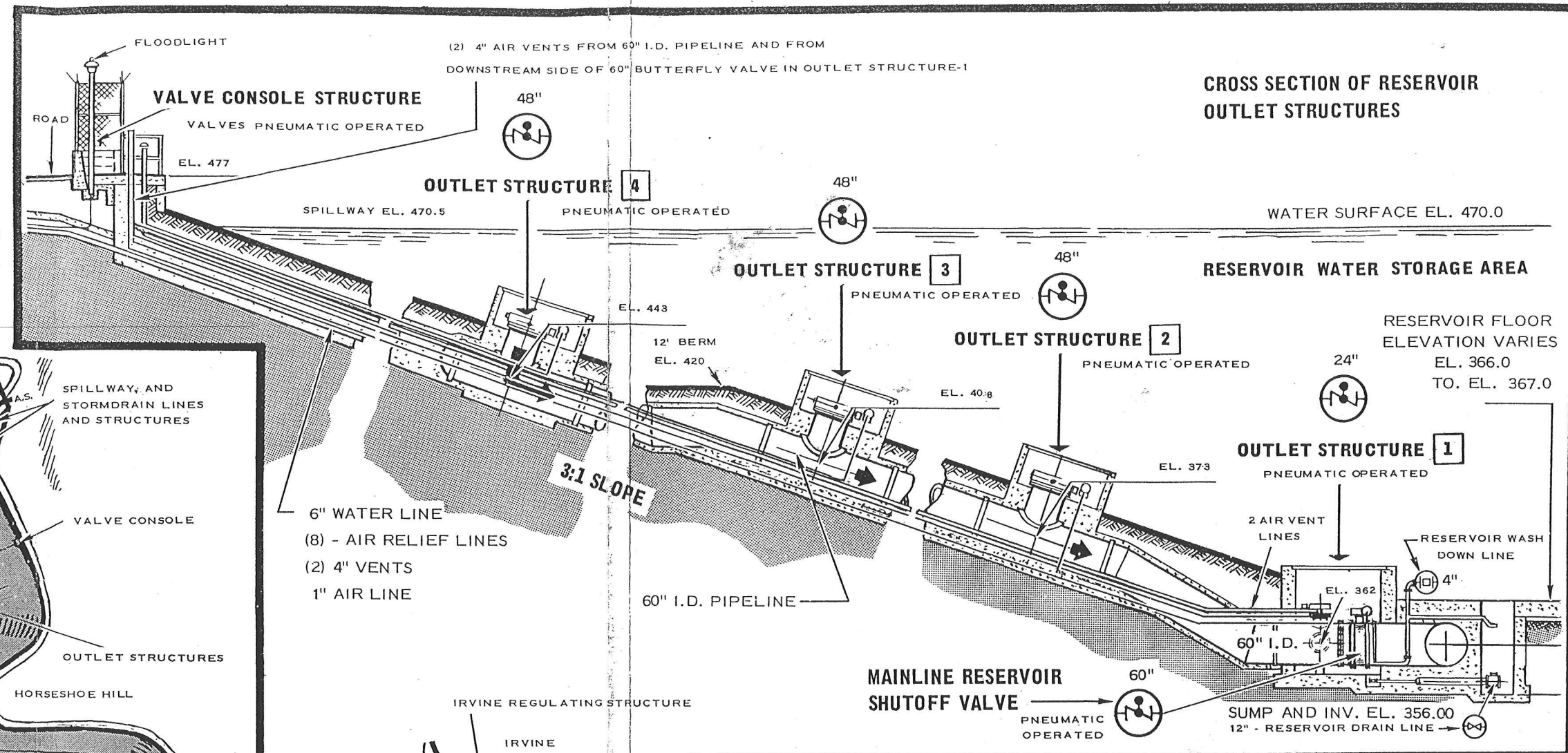

NORTH OF THE CITY OF NEWPORT BEACH, AND CORONA DEL MAR, ORANGE COUNTY

SAN JOAQUIN RESERVOIR

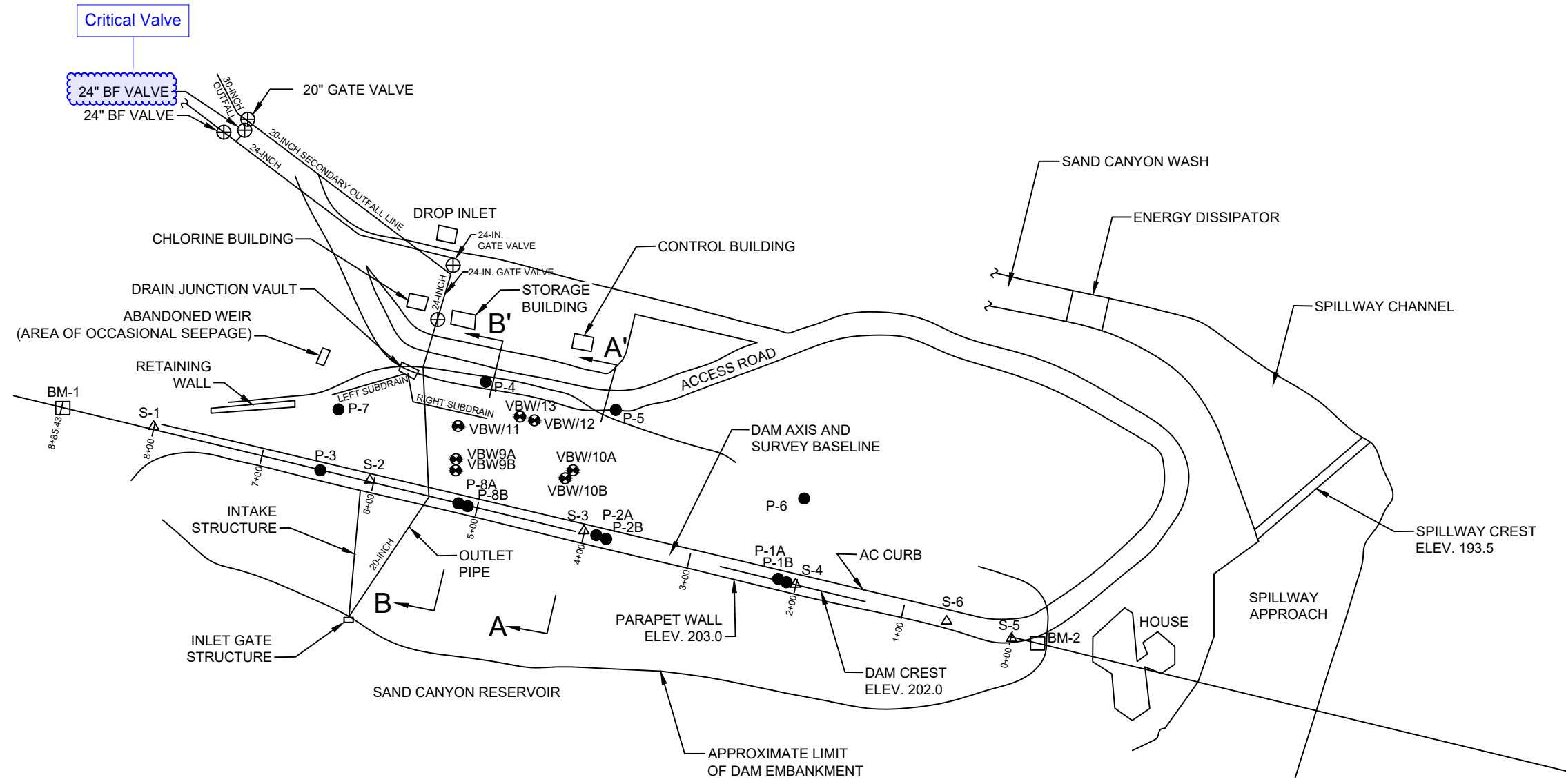

LEGEND

- ⊕ VBW/13 VIBRATING WIRE PIEZOMETER
- P-2A OPEN WELL PIEZOMETER
- △ S-3 SURVEY MONUMENT
- BM-1 BENCH MARK
- A — A' LINE OF SECTION
- — — — — OUTLET PIPE
- — — — — SEEPAGE SUBDRAIN
- 0+00 — STATION NUMBER

- NOTES:**
- (1) SECTION A-A' IS SHOWN ON FIGURE 2
 - (2) SECTION B-B' IS SHOWN ON FIGURE 3
 - (3) ELEVATIONS ARE IN FEET RELATIVE TO NGVD29 DATUM
 - (4) LOCATIONS OF OUTLET PIPES AND VALVES ARE ESTIMATED

NOT TO SCALE

Annual Surveillance Report from Jan. 2021 to Dec. 2021 Sand Canyon Dam Irvine, CA		SITE AND INSTRUMENTATION PLAN	
Irvine Ranch Water District Irvine, CA		Project 1901888	August 2022

Fig. 1

Exhibit 6.2
Location of Critical Valve at Sand Canyon Dam

AS-BUILT DRAWING

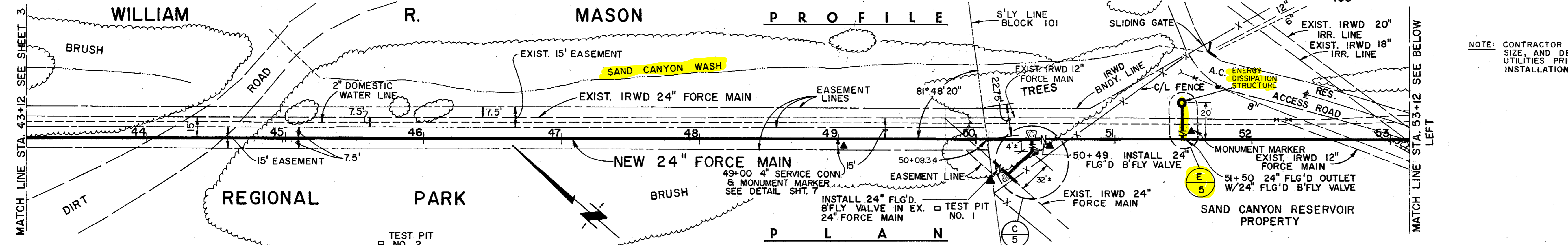
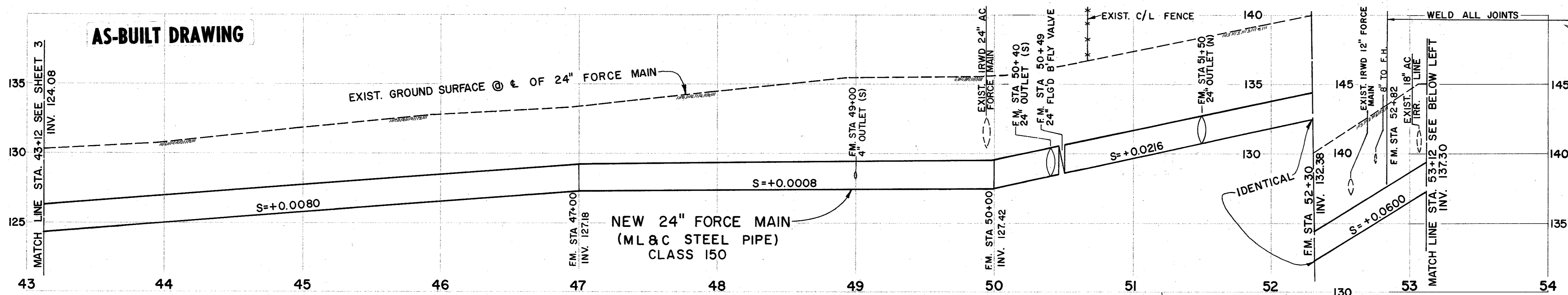

NOTE: CONTRACTOR SHALL VERIFY LOCATION, TYPE, SIZE, AND DEPTH OF ALL PIPING AND UTILITIES PRIOR TO PIPE FABRICATION AND INSTALLATION.

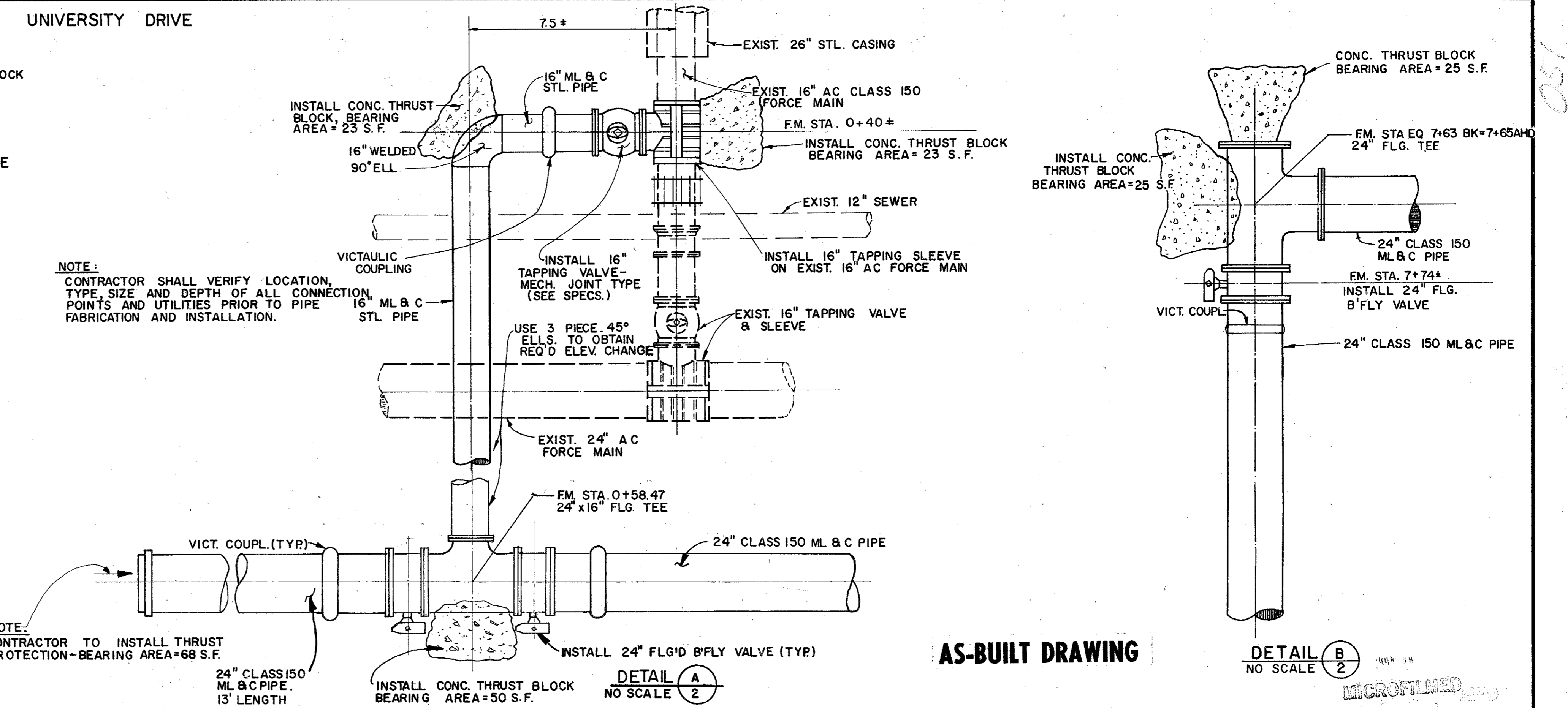
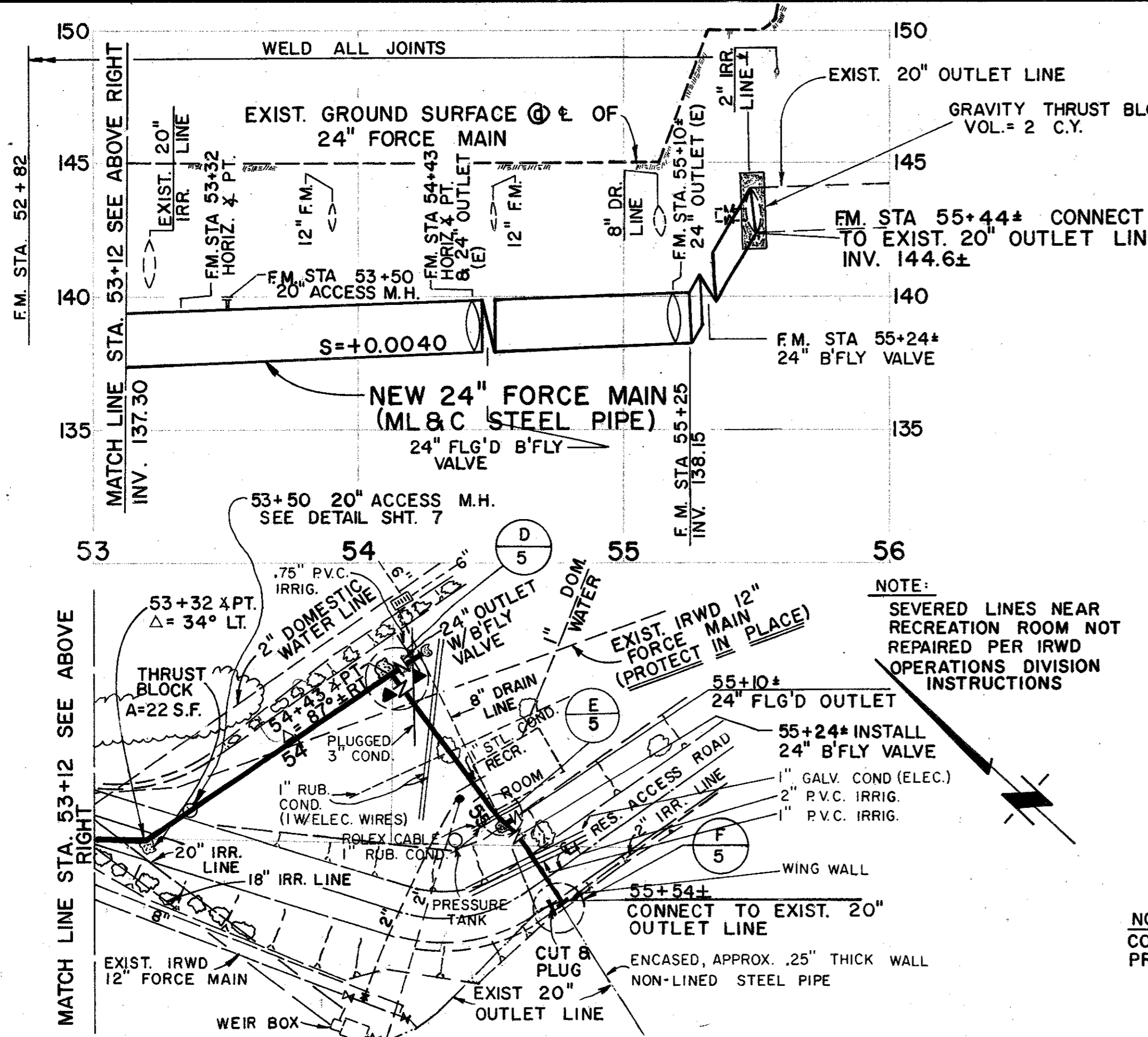

NOTE: CONTRACTOR SHALL VERIFY LOCATION, TYPE, SIZE AND DEPTH OF ALL CONNECTION, POINTS AND UTILITIES PRIOR TO PIPE FABRICATION AND INSTALLATION.

NOTE: SEVERED LINES NEAR RECREATION ROOM NOT REPAIRED PER IRWD OPERATIONS DIVISION INSTRUCTIONS

NOTE: CONTRACTOR TO INSTALL THRUST PROTECTION-BEARING AREA=68 S.F.

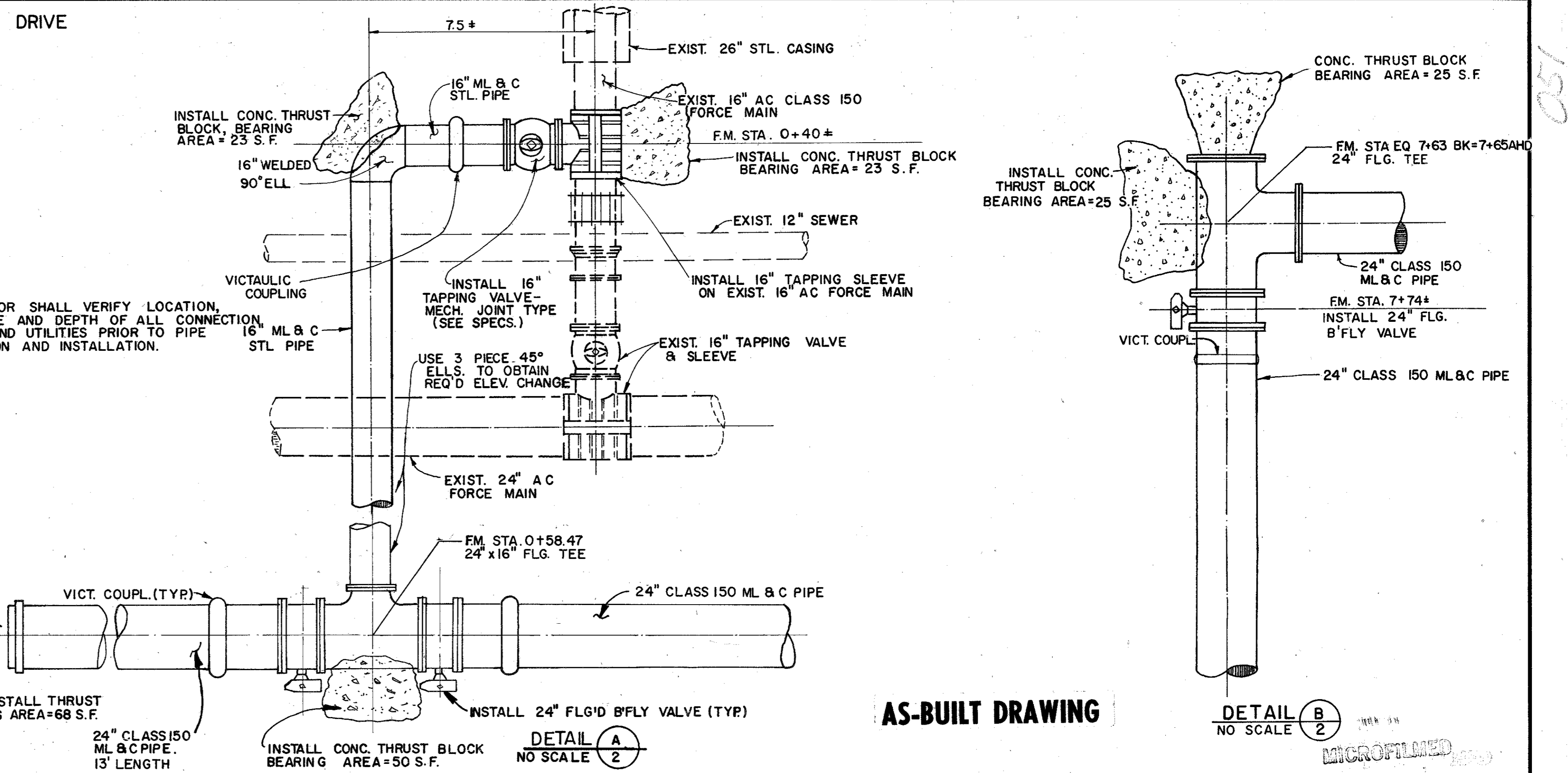

AS-BUILT DRAWING

1	17/19/77	RFS	AS BUILT
REV	DATE	BY	DESCRIPTION

SCALE:	HORIZ. 1" = 40'
VERT. 1" = 4'	

SUBMITTED	2/16/86	1/15/86
PROJECT ENGINEER	R.C.E. NO.	DATE
RECOMMENDED	1388	10-15-76
JAMES M. MONTGOMERY CONSULTING ENGINEERS, INC.	R.C.E. NO.	DATE

JAMES M. MONTGOMERY CONSULTING ENGINEERS, INC.
17802 SKY PARK CIRCLE, IRVINE, CALIFORNIA 92714

APPROVED	DATE
APPROVED	DATE

IRVINE RANCH WATER DISTRICT	SHEET 4
SAND CANYON RESERVOIR RECLAIMED WATER FORCE MAIN	
PLAN AND PROFILE & MISC. DETAILS	
STA. 43+12 TO STA. 55+44*	OF 8 SHEETS

AS-BUILT DRAWING

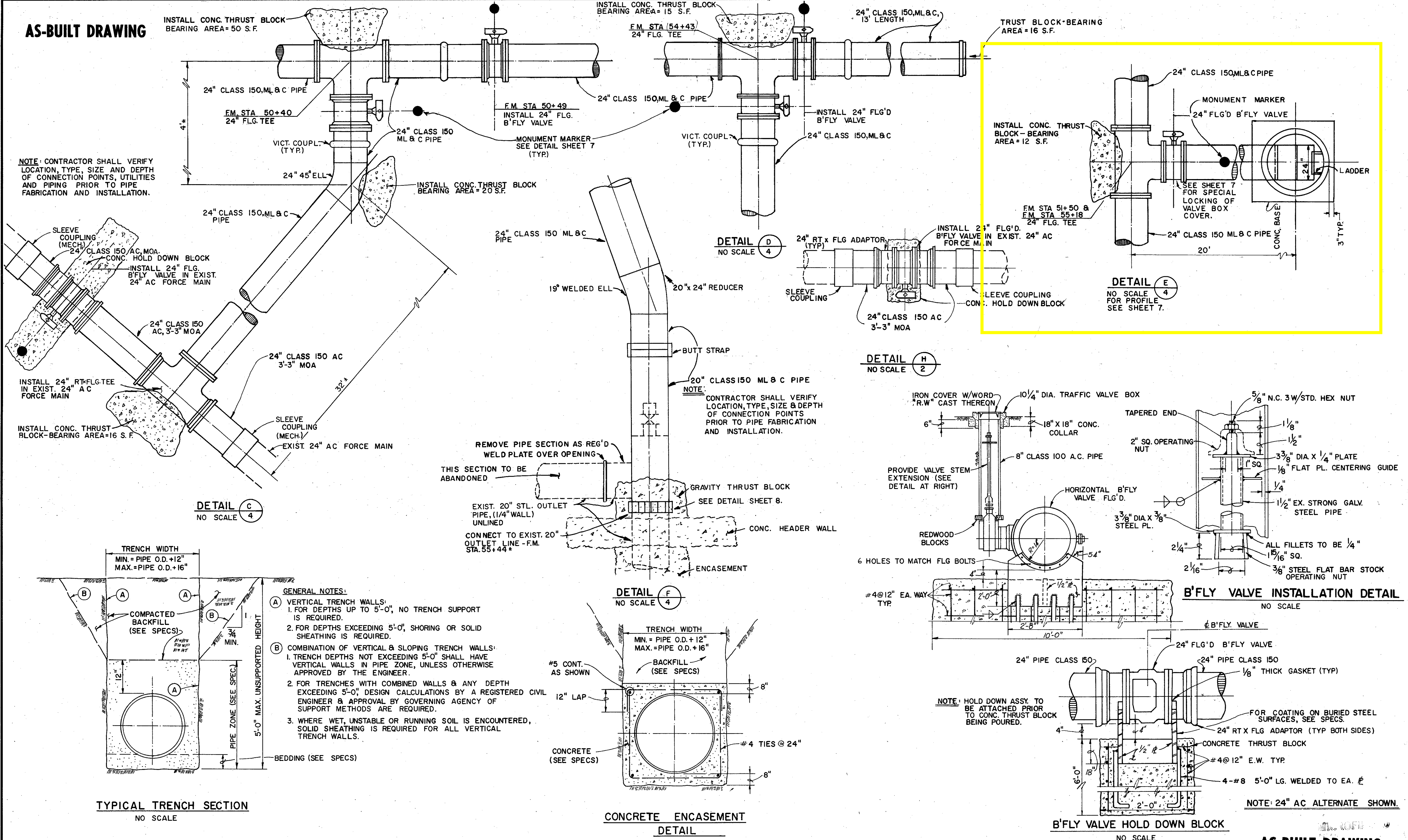

NOTE: CONTRACTOR SHALL VERIFY LOCATION, TYPE, SIZE AND DEPTH OF CONNECTION POINTS, UTILITIES AND PIPING PRIOR TO PIPE FABRICATION AND INSTALLATION.

INSTALL CONC. THRUST BLOCK BEARING AREA = 50 S.F.

INSTALL CONC. THRUST BLOCK BEARING AREA = 15 S.F.

TRUST BLOCK BEARING AREA = 16 S.F.

F.M. STA 50+40
24" FLG. TEE

F.M. STA 50+49
INSTALL 24" FLG. B' FLY VALVE

F.M. STA 51+50 & F.M. STA 55+18
24" FLG. TEE

24" CLASS 150, ML & C PIPE

INSTALL CONC. THRUST BLOCK BEARING AREA = 20 S.F.

24" CLASS 150, ML & C PIPE

24" CLASS 150, ML & C PIPE

INSTALL CONC. THRUST BLOCK BEARING AREA = 12 S.F.

24" CLASS 150, ML & C PIPE

MONUMENT MARKER

24" FLG'D B' FLY VALVE

SEE SHEET 7 FOR SPECIAL LOCKING OF VALVE BOX COVER.

F.M. STA 51+50 & F.M. STA 55+18
24" FLG. TEE

24" CLASS 150 ML & C PIPE

DETAIL E
NO SCALE FOR PROFILE SEE SHEET 7.

SLEEVE COUPLING (MECH.)
24" CLASS 150/AC, MOA
CONC. HOLD DOWN BLOCK
INSTALL 24" FLG. B' FLY VALVE IN EXIST. 24" AC FORCE MAIN

24" CLASS 150 AC, 3'-3" MOA

24" CLASS 150 AC, 3'-3" MOA

INSTALL 24" RT-FLG-TEE IN EXIST. 24" AC FORCE MAIN

INSTALL CONC. THRUST BLOCK BEARING AREA = 16 S.F.

SLEEVE COUPLING (MECH.)

EXIST. 24" AC FORCE MAIN

DETAIL C
NO SCALE

24" CLASS 150 ML & C PIPE

19" WELDED ELL

20" x 24" REDUCER

BUTT STRAP

20" CLASS 150 ML & C PIPE

NOTE: CONTRACTOR SHALL VERIFY LOCATION, TYPE, SIZE & DEPTH OF CONNECTION POINTS PRIOR TO PIPE FABRICATION AND INSTALLATION.

REMOVE PIPE SECTION AS REG'D WELD PLATE OVER OPENING
THIS SECTION TO BE ABANDONED

GRAVITY THRUST BLOCK

SEE DETAIL SHEET 8.

EXIST. 20" STL. OUTLET PIPE, (1 1/4" WALL) UNLINED

CONNECT TO EXIST. 20" OUTLET LINE - F.M. STA. 55+44*

CONC. HEADER WALL

ENCASEMENT

DETAIL F
NO SCALE

TRENCH WIDTH
MIN. = PIPE O.D. + 12"
MAX. = PIPE O.D. + 16"

BACKFILL (SEE SPECS)

#5 CONT. AS SHOWN

12" LAP

CONCRETE (SEE SPECS)

#4 TIES @ 24"

CONCRETE ENCASEMENT
DETAIL
NO SCALE

IRON COVER W/WORD "R.W." CAST THEREON

10 1/4" DIA. TRAFFIC VALVE BOX

18" X 18" CONC. COLLAR

PROVIDE VALVE STEM EXTENSION (SEE DETAIL AT RIGHT)

8" CLASS 100 A.C. PIPE

REDWOOD BLOCKS

6 HOLES TO MATCH FLG BOLTS

#4 @ 12" EA. WAY TYP.

5/8" N.C. 3W/STD. HEX NUT

1 1/8"

1/2"

3 3/8" DIA. X 1/4" PLATE

1/8" SQ. CENTERING GUIDE

1 1/2" EX. STRONG GALV. STEEL PIPE

3 3/8" DIA. X 3/8" STEEL PL.

2 1/16"

2 1/16"

ALL FILLETS TO BE 1/4"

1 5/16" SQ.

3/8" STEEL FLAT BAR STOCK OPERATING NUT

B' FLY VALVE INSTALLATION
DETAIL
NO SCALE

NOTE: HOLD DOWN ASSY. TO BE ATTACHED PRIOR TO CONC. THRUST BLOCK BEING POURED.

24" FLG'D B' FLY VALVE

24" PIPE CLASS 150

1/8" THICK GASKET (TYP)

FOR COATING ON BURIED STEEL SURFACES, SEE SPECS.

24" RT X FLG ADAPTOR (TYP BOTH SIDES)

CONCRETE THRUST BLOCK

#4 @ 12" E.W. TYP.

4 - #8 5'-0" LG. WELDED TO EA. #

NOTE: 24" AC ALTERNATE SHOWN.

B' FLY VALVE HOLD DOWN BLOCK
NO SCALE

TRENCH WIDTH
MIN. = PIPE O.D. + 12"
MAX. = PIPE O.D. + 16"

COMPACTED BACKFILL (SEE SPECS)

5'-0" MAX. UNSUPPORTED HEIGHT

PIPE ZONE (SEE SPEC)

12"

3/4" MIN.

5'-0" MAX. UNSUPPORTED HEIGHT

BEDDING (SEE SPECS)

TYPICAL TRENCH SECTION
NO SCALE

- GENERAL NOTES:
- (A) VERTICAL TRENCH WALLS:
 - FOR DEPTHS UP TO 5'-0", NO TRENCH SUPPORT IS REQUIRED.
 - FOR DEPTHS EXCEEDING 5'-0", SHORING OR SOLID SHEATHING IS REQUIRED.
 - (B) COMBINATION OF VERTICAL & SLOPING TRENCH WALLS:
 - TRENCH DEPTHS NOT EXCEEDING 5'-0" SHALL HAVE VERTICAL WALLS IN PIPE ZONE, UNLESS OTHERWISE APPROVED BY THE ENGINEER.
 - FOR TRENCHES WITH COMBINED WALLS & ANY DEPTH EXCEEDING 5'-0", DESIGN CALCULATIONS BY A REGISTERED CIVIL ENGINEER & APPROVAL BY GOVERNING AGENCY OF SUPPORT METHODS ARE REQUIRED.
 - WHERE WET, UNSTABLE OR RUNNING SOIL IS ENCOUNTERED, SOLID SHEATHING IS REQUIRED FOR ALL VERTICAL TRENCH WALLS.

1	5/17/77	VCS	AS BUILT	SCALE:	AS SHOWN	DESIGNED	RFS	SUBMITTED	10/15/76
						DRAWN	RFS	PROJECT ENGINEER	10/15/76
						CHECKED	DRL	RECOMMENDED	10-15-76
								JAMES M. MONTGOMERY CONSULTING ENGINEERS, INC.	

JAMES M. MONTGOMERY CONSULTING ENGINEERS, INC.
17802 SKY PARK CIRCLE, IRVINE, CALIFORNIA 92714

APPROVED	DATE	IRVINE RANCH WATER DISTRICT	SHEET
APPROVED	DATE	SAND CANYON RESERVOIR RECLAIMED WATER FORCE MAIN	5
APPROVED	DATE	MISCELLANEOUS DETAILS	OF 8 SHEETS

AS-BUILT DRAWING
MICROFILMED

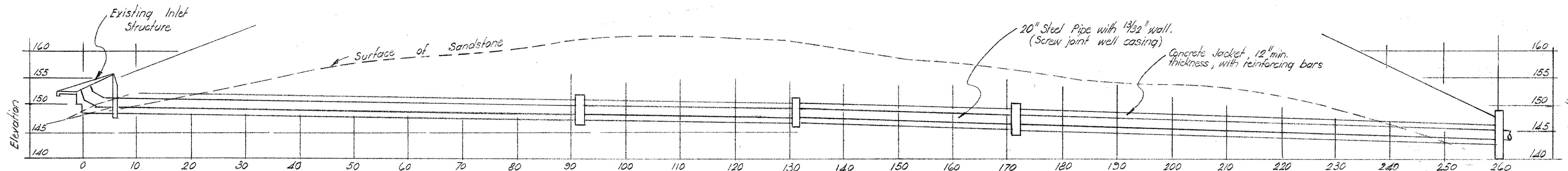

PROFILE of EXISTING CONDUIT

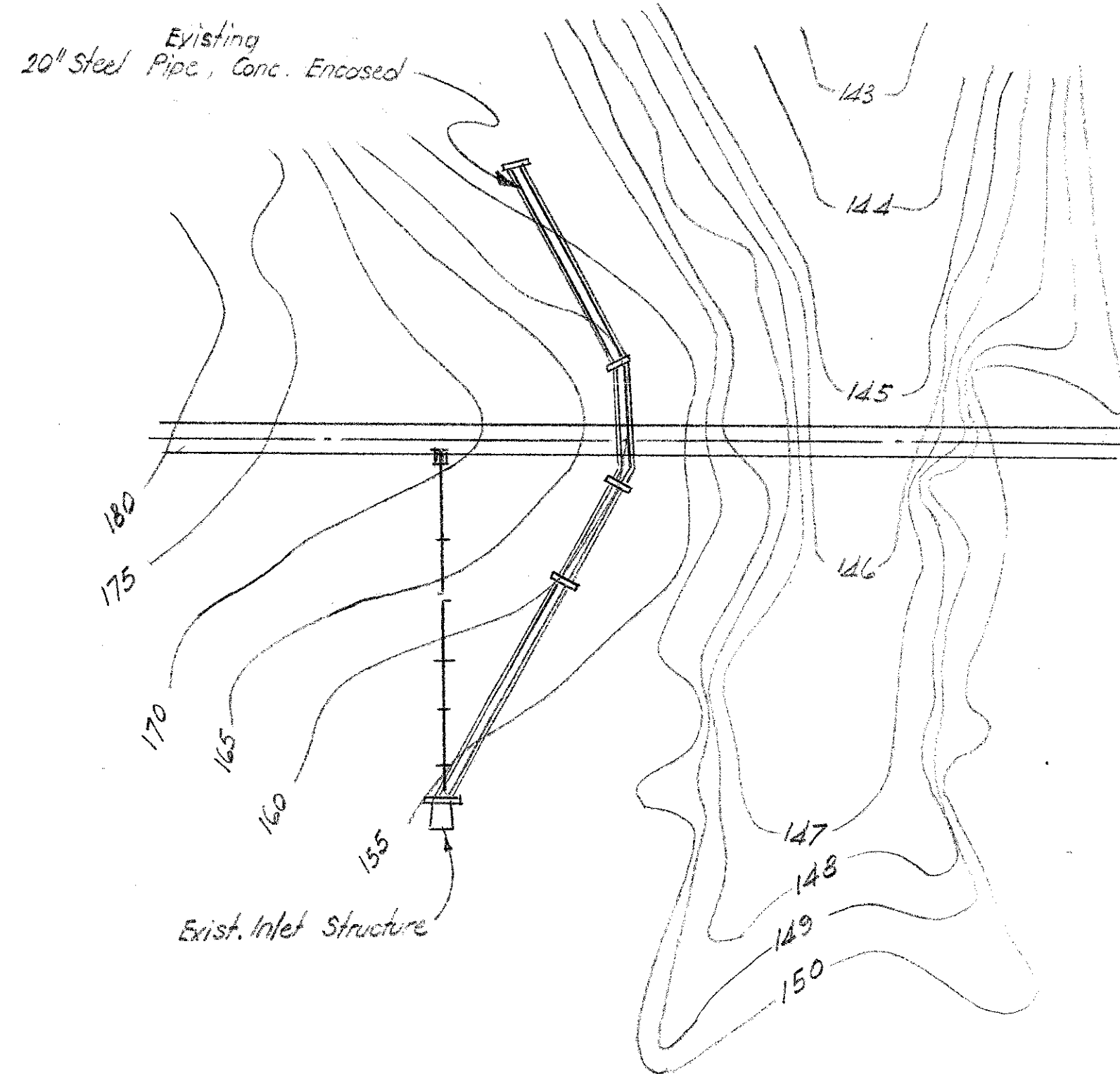

PLAN of EXISTING OUTLET PIPE

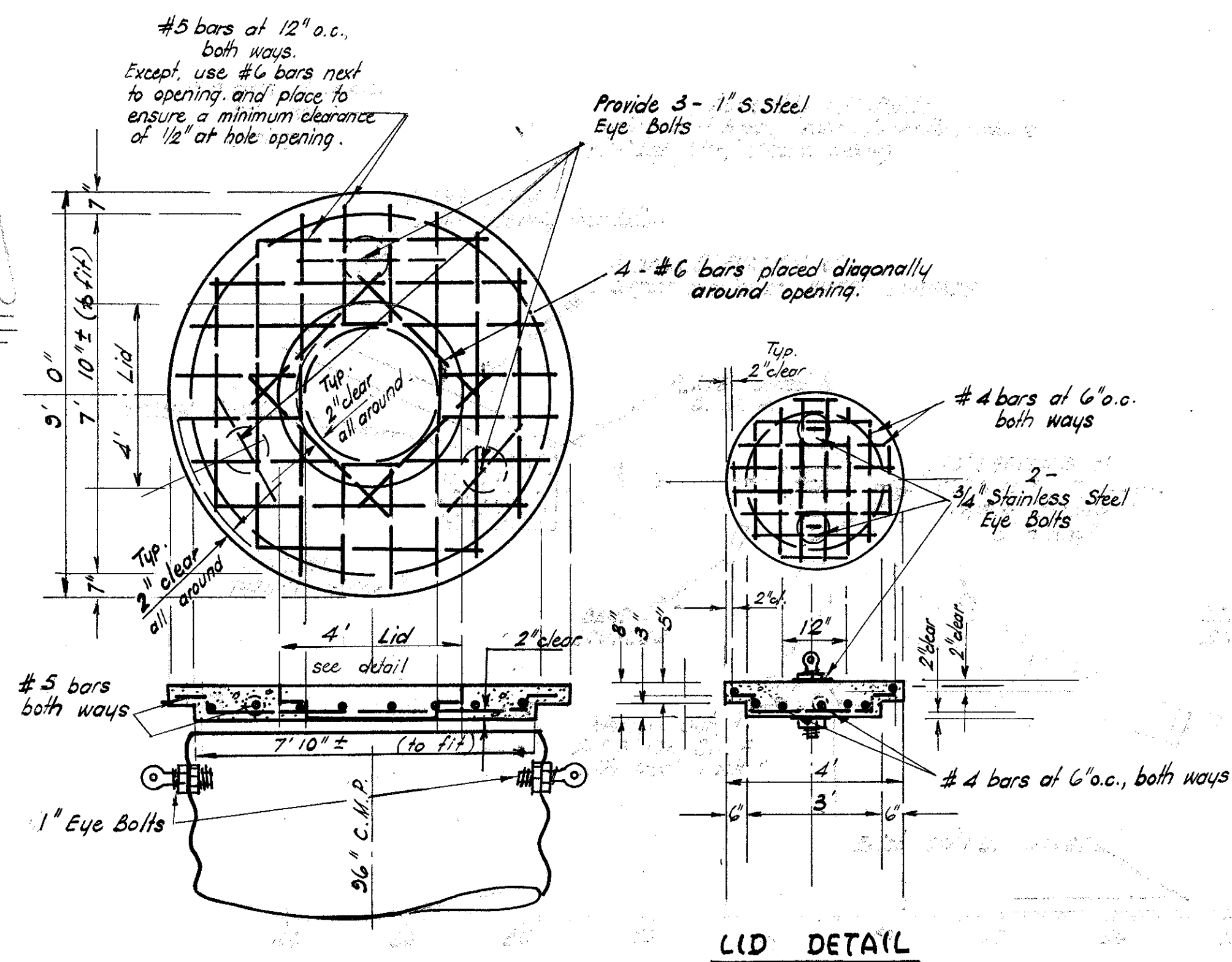

VAULT COVER DETAIL

Scale 3/8" = 1' 0"

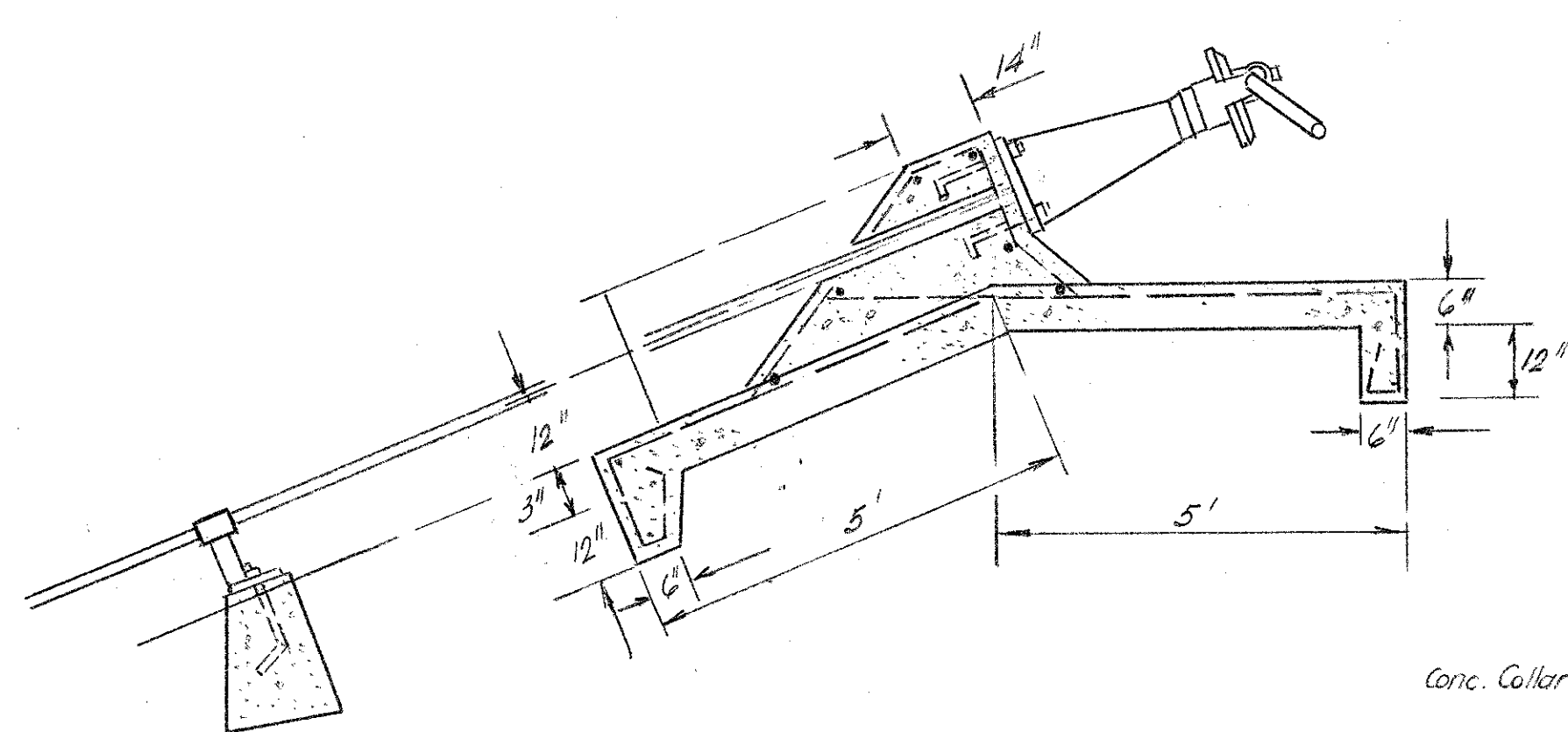

EXISTING LIFT ASSEMBLY FOUNDATION

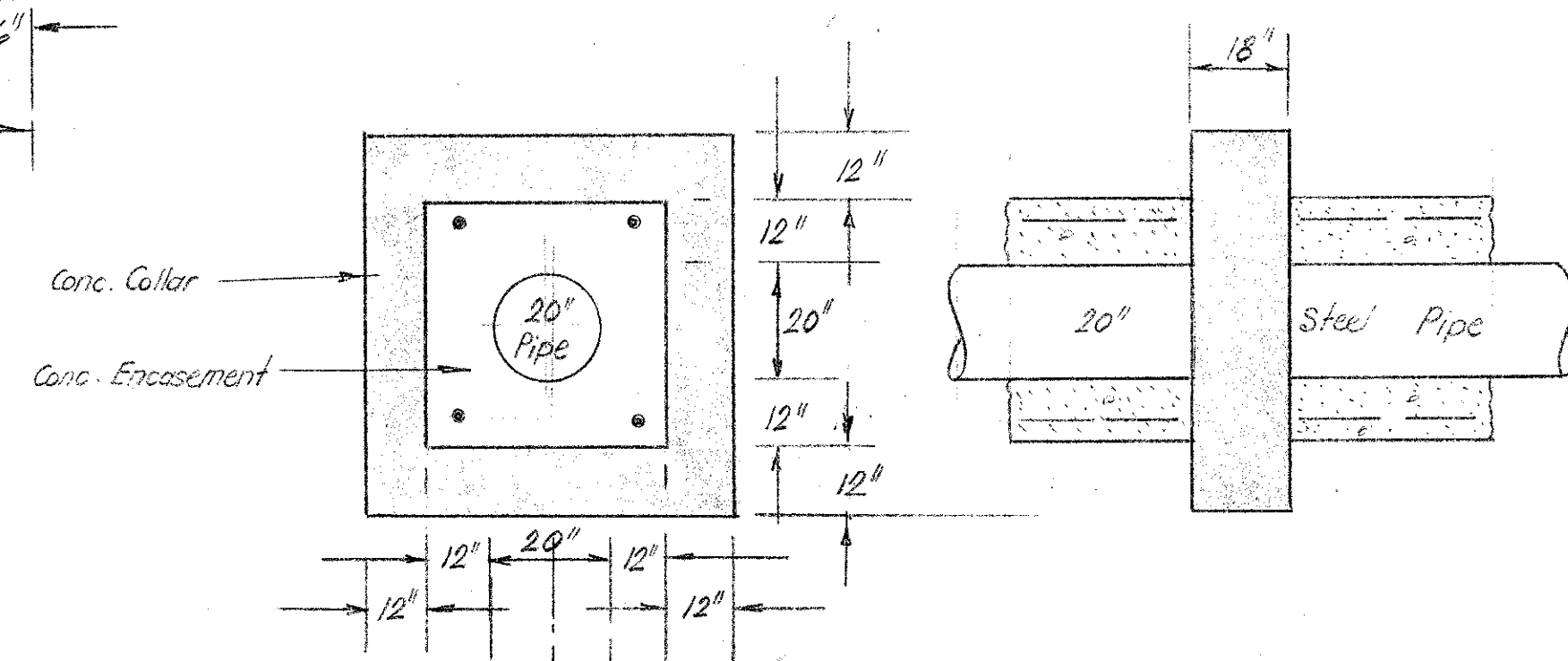

EXISTING CUTOFF COLLAR DETAIL - Outlet Pipe

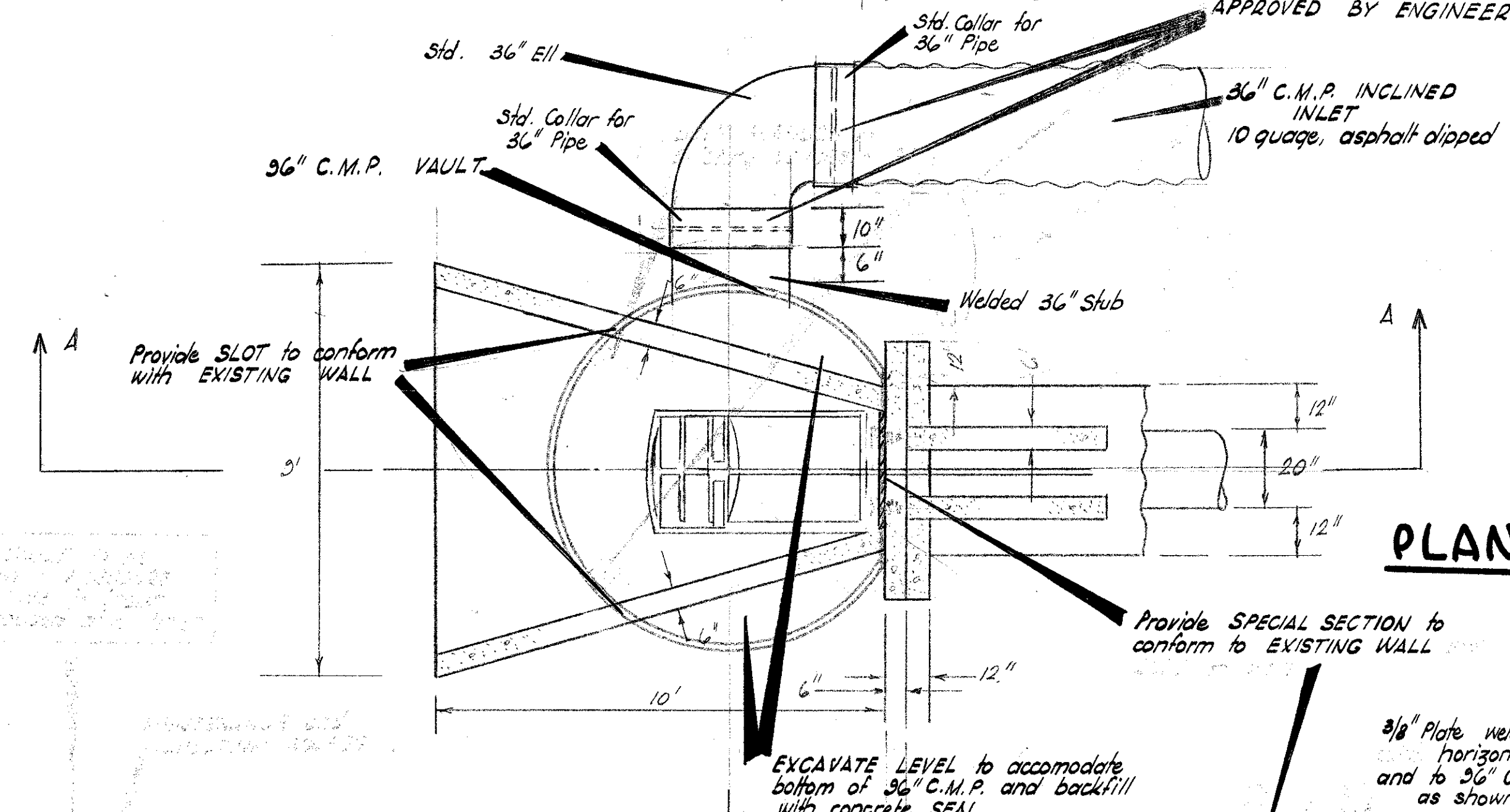

PLAN

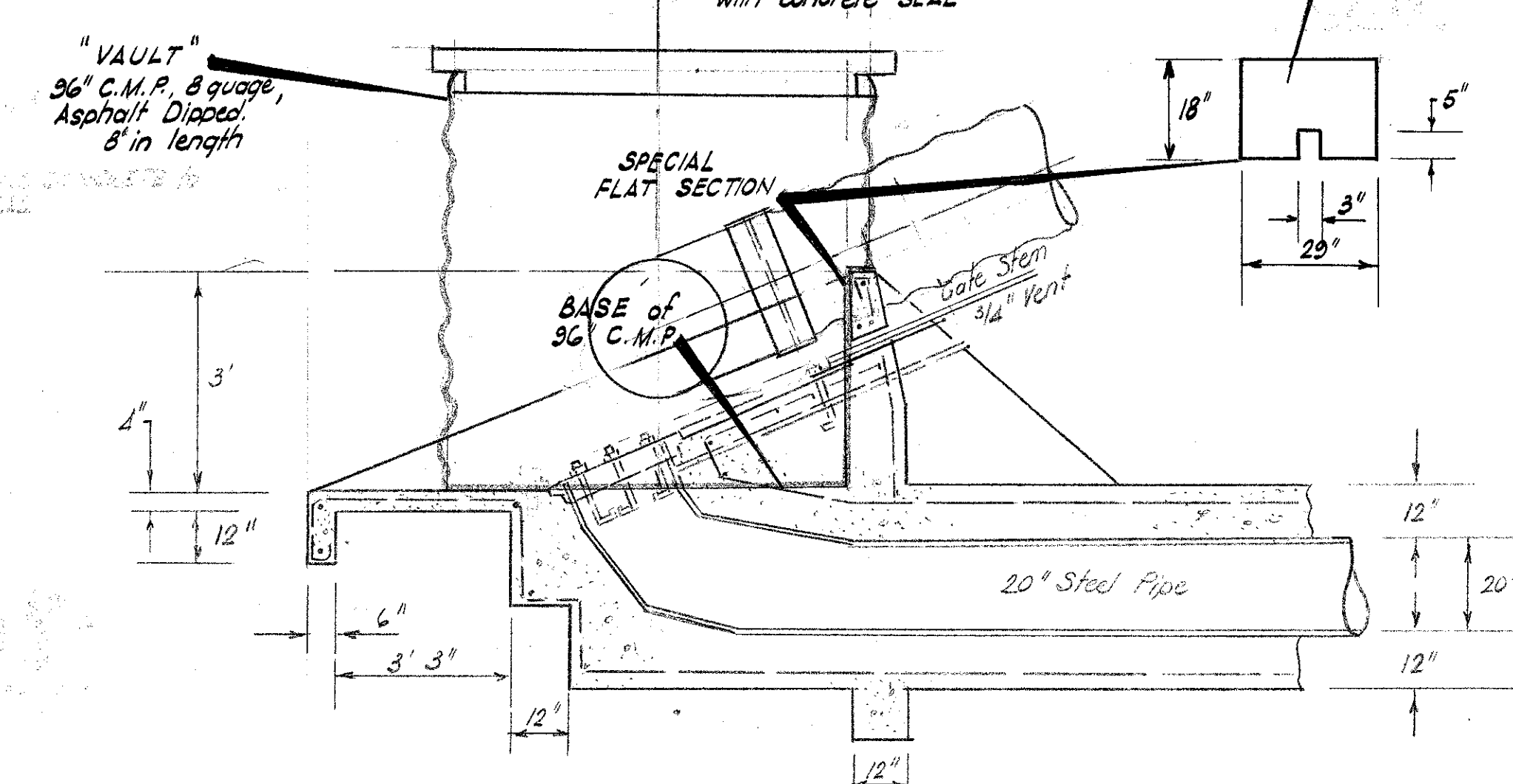

**C.M.P. VAULT & SECTION A-A
DETAILS of EXISTING INLET STRUCTURE
(with modifications)**

APPROVED *Gary L. Guffman* DATE 23 Aug 75
GARY L. GUFFMAN PR.D. RE. No. C 24502

**SAND CANYON RESERVOIR
OUTLET WORKS**

Revised 3-4-75, 9-11-75, 3-16-75

SHEET 1 of 2 SHEETS

E14 37501 - 116 18395
100 Sand Canyon Outlet Works - Sand Canyon Reservoir

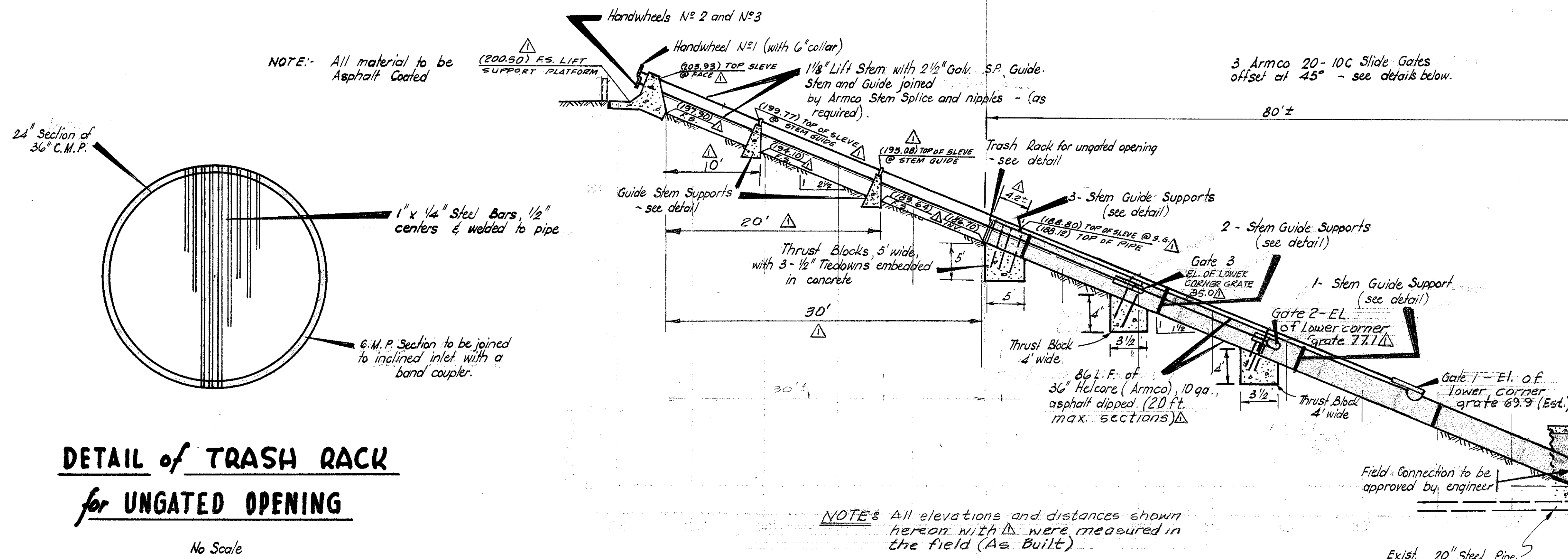

DETAIL of TRASH RACK for UNGATED OPENING

No Scale

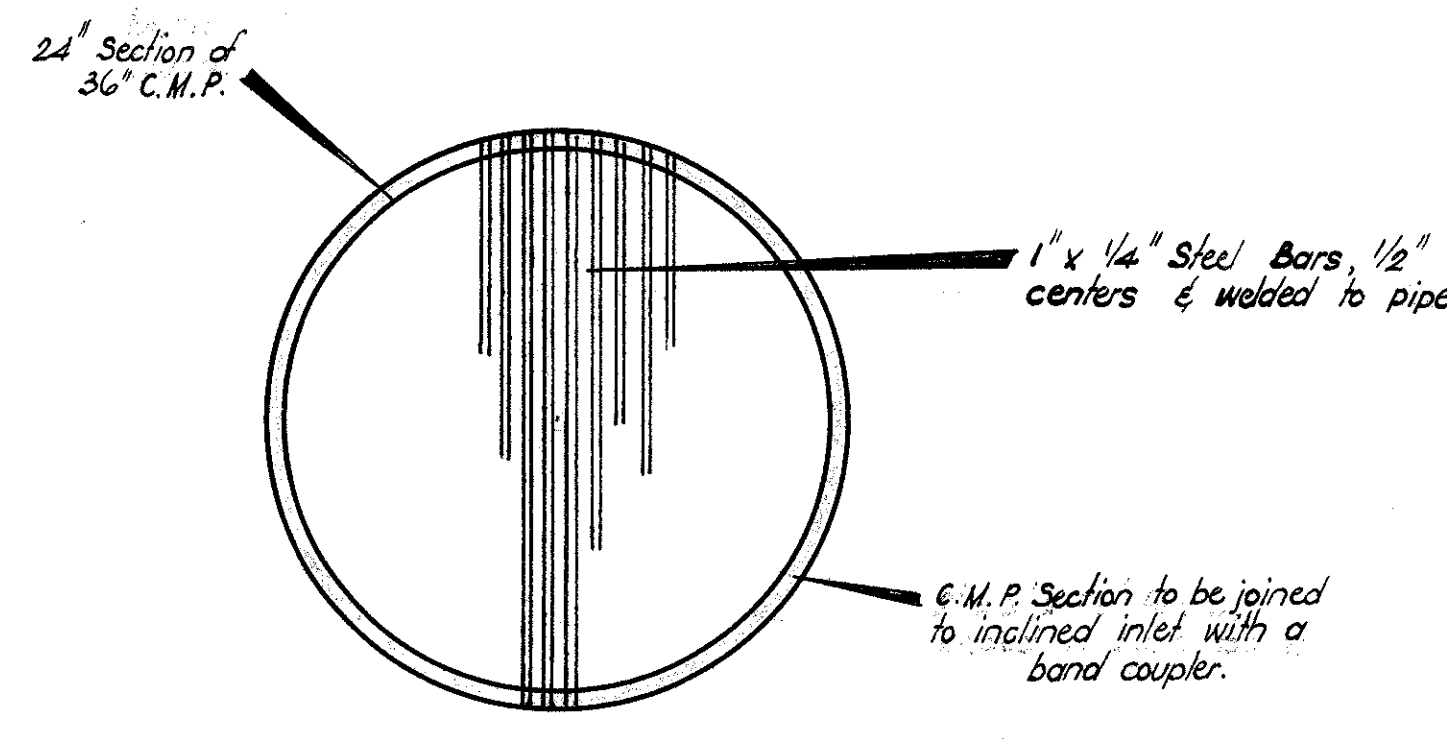

NOTE: All elevations and distances shown hereon with Δ were measured in the field (As Built)

INCLINED INLET

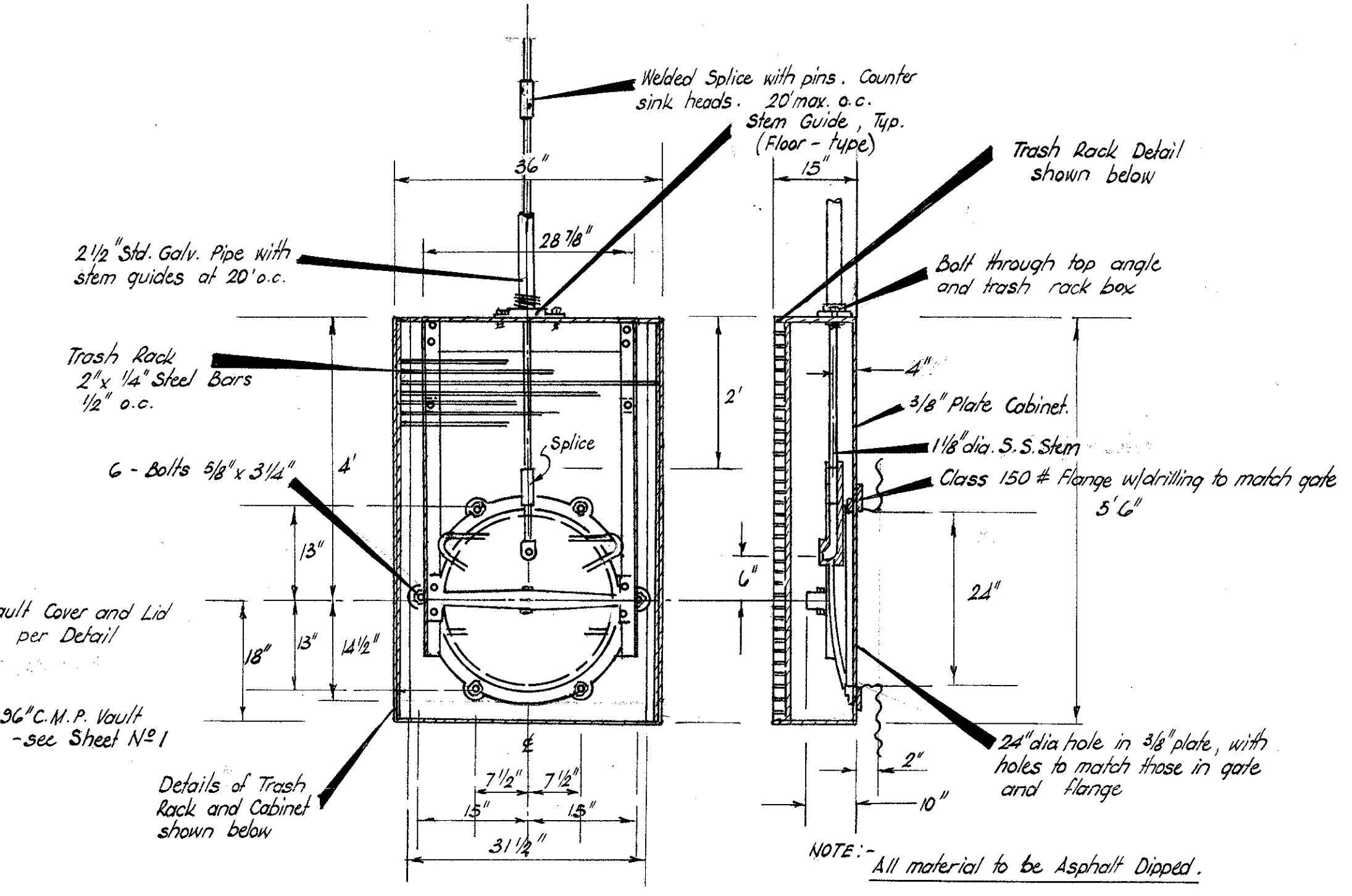

DETAIL of GATE ASSEMBLIES

(3 REQUIRED)

DETAIL of STEM GUIDE

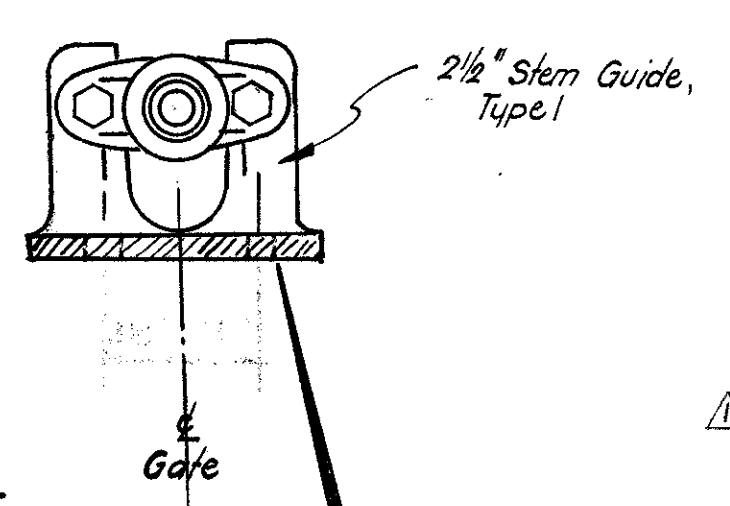

Arcoa Type 1, 2 1/2" Stem Guides, attached with welded 2 1/2" x 3/4" Studs. Provide as needed on the three separate assemblies

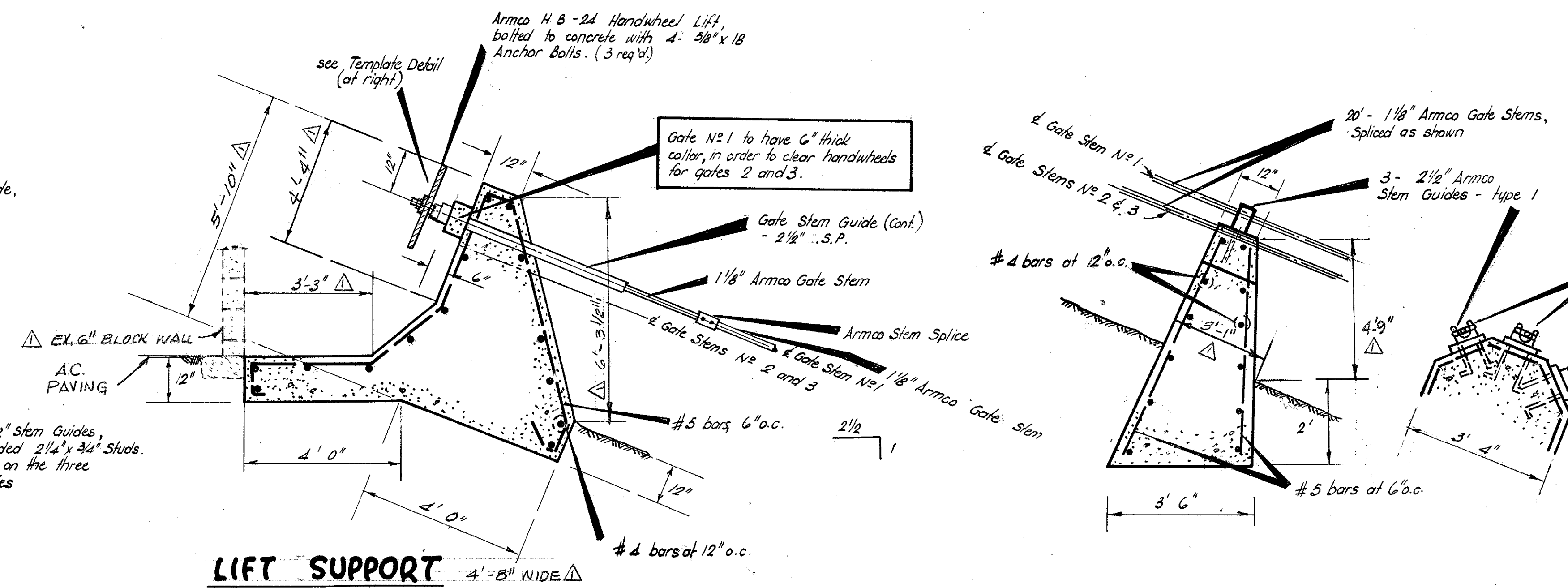

LIFT SUPPORT

STEM GUIDE SUPPORTS

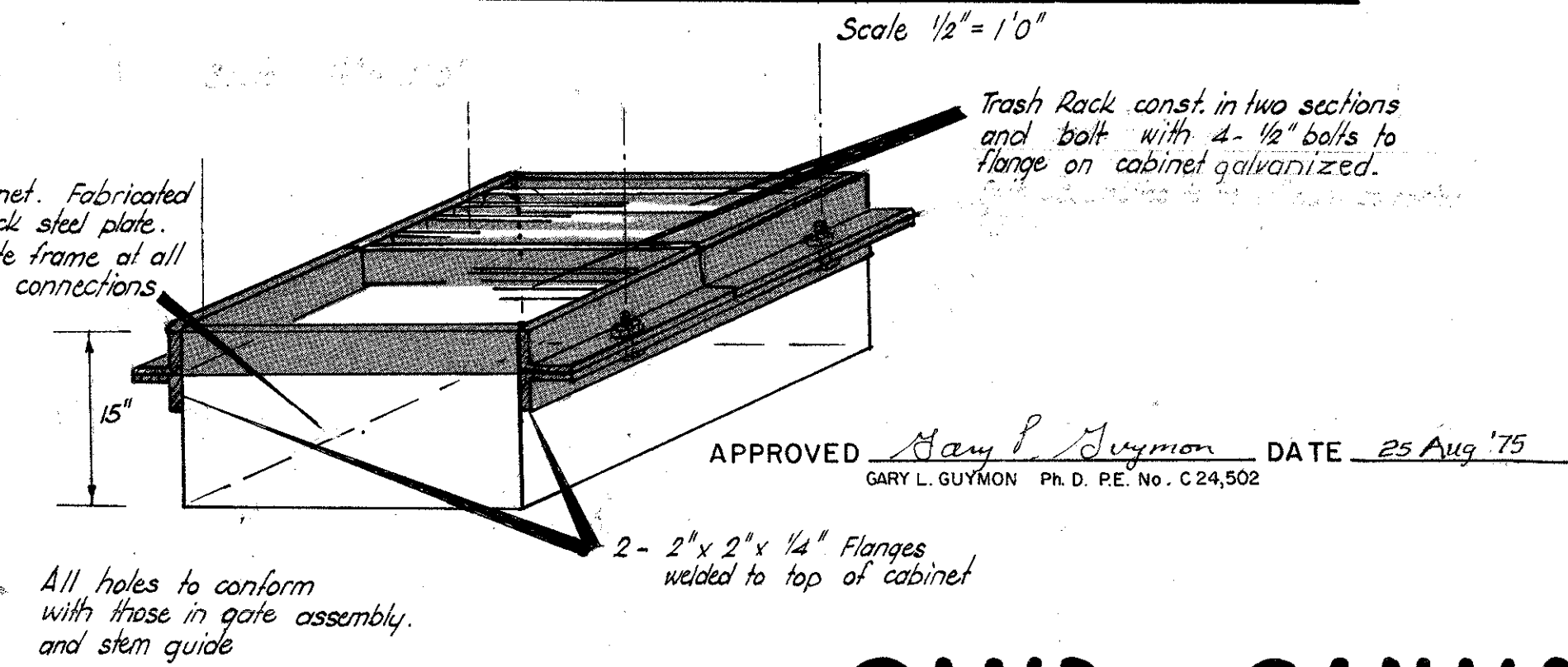

TEMPLATE for POSITIONING HANDWHEEL LIFTS

- NOTES:
1. Surface of Reservoir slope shall be cleaned of all debris and 36-inch C.M.P. provided with smooth solid base.
 2. All machine bolts, nuts and washers shall be Type 316 Stainless Steel.
 3. The Contractor shall verify all notes and dimensions prior to starting any work or fabrication of pipe and structures.
 4. Slide Gate guides shall be installed per manufacturing recommendations. Max. spacing 20' c.c. on stem guides.

DETAIL of STEM GUIDE SUPPORT (6 REQUIRED)

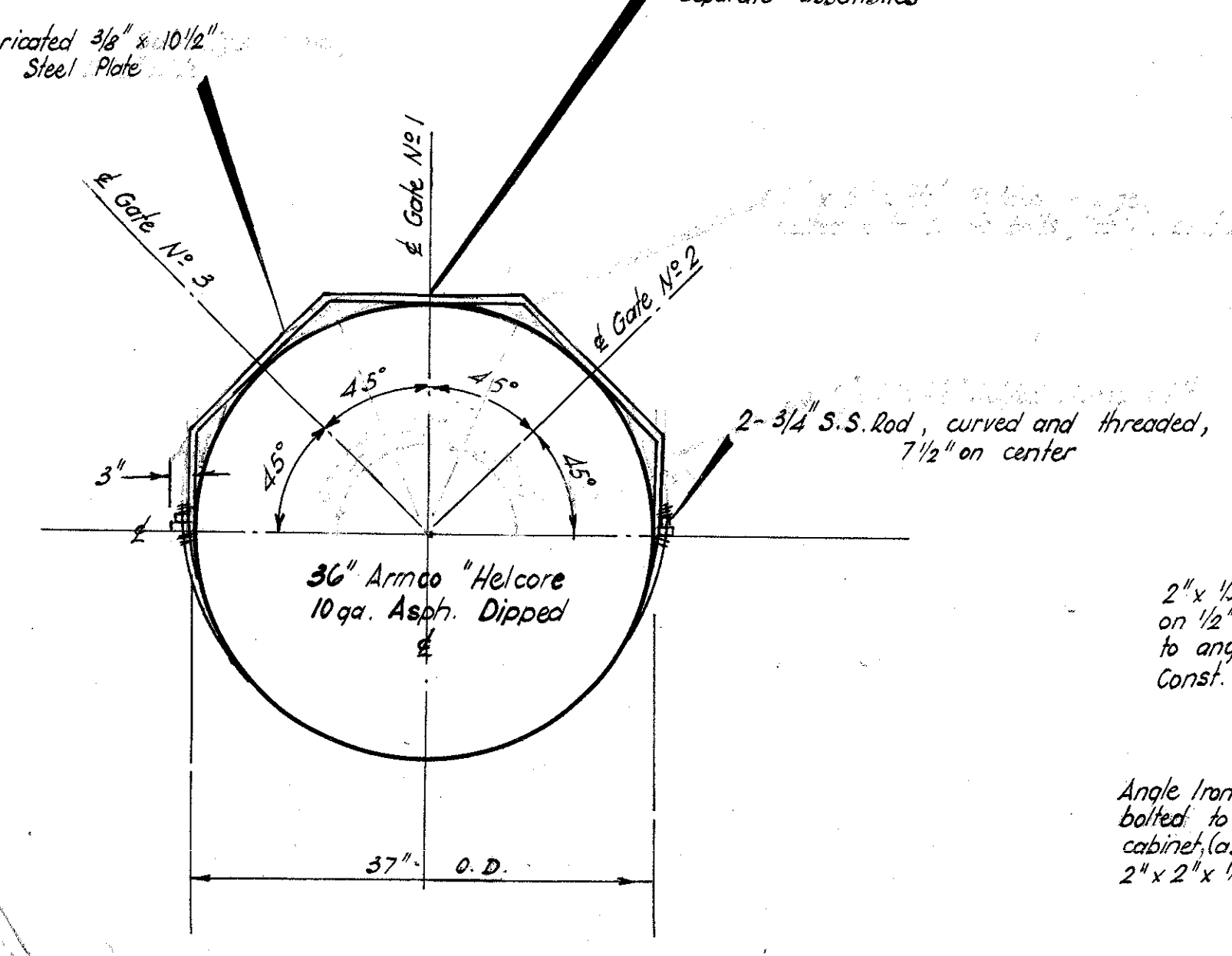

DETAIL of TRASH RACK at GATED OPENINGS

No Scale

SAND CANYON RESERVOIR OUTLET WORKS

AS BUILT

Revised 3-4-75, 3-11-75, 3-16-75, 12-5-75 SHEET 2 of 2 SHEETS



LEGEND

- Emergency Outlet
- Main Outlet
- Main Inlet
- ⊗ Emergency Valve, Normally Closed
- ⊗ Valve Normally Open
- ⊗ Valve Normally Closed
- #* DSOD Valve

NOTES

① 20" STL LINE PREVIOUSLY ABANDONED. REVIVED BY CONSTRUCTION SERVICES AND CONNECTED TO 30" EMERGENCY DUMP IN APPROX. 2008 (REF. BILL WESSON, 2023)

NO.	DATE	REVISIONS	APPROVED
2	4/11/2024	VALVE SIZES REVISED, METER BOX ADDED	DD

DSOD Valves: 7", 9", 11", 12", 19", 20", 21"

BILL WESSON NAME	WATER OPERATIONS SUPERVISOR	DATE
DANIELLE DRAKE NAME	ASSISTANT ENGINEER	DATE
JACOB MOEDER NAME	IRWD ENGINEERING MANAGER	DATE



DEVELOPED BY ENGINEERING INTERNS:
TINH NGUYEN
RYAN TRAN

SAND CANYON DAM
PIPELINE SCHEMATIC

SHEET
01
01 of 05
1477 SHEETS

AUGUST 2023

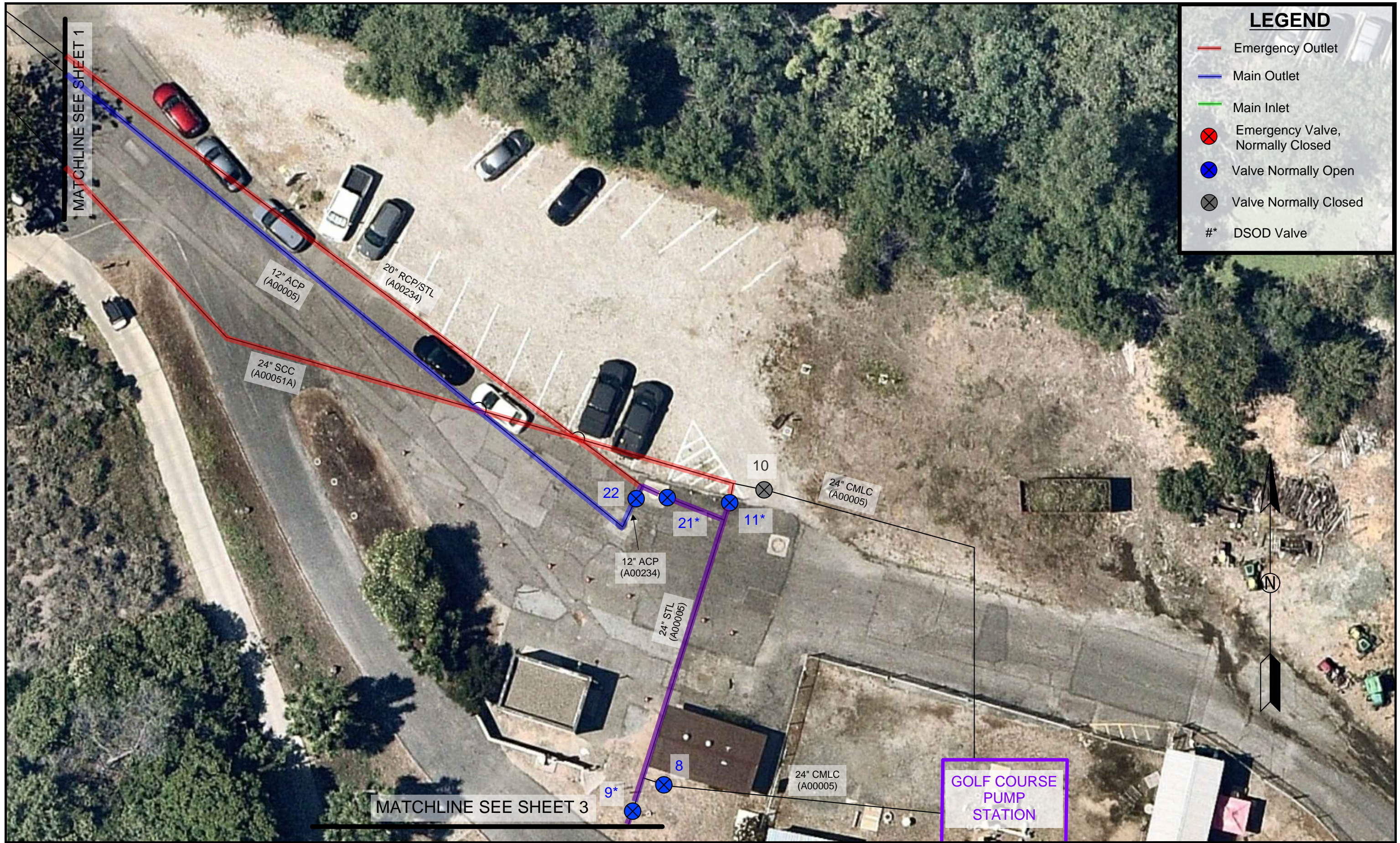

LEGEND

- Emergency Outlet
- Main Outlet
- Main Inlet
- ⊗ Emergency Valve, Normally Closed
- ⊗ Valve Normally Open
- ⊗ Valve Normally Closed
- #* DSOD Valve



NO.	DATE	REVISIONS	APPROVED

DSOD Valves: 7*, 9*, 11*, 12*, 19*, 20*, 21*

BILL WESSON NAME	WATER OPERATIONS SUPERVISOR	DATE
DANIELLE DRAKE NAME	ASSISTANT ENGINEER	DATE
JACOB MOEDER NAME	IRWD ENGINEERING MANAGER	DATE



DEVELOPED BY ENGINEERING INTERNS:
TINH NGUYEN
RYAN TRAN

SAND CANYON DAM
PIPELINE SCHEMATIC

SHEET
02
02 of 05
148 SHEETS

AUGUST 2023



LEGEND

- Vibrating Wire Piezometer (VBW)
- Open-Well Piezometer (P)
- ⊗ Outlet Gate Valves

MATCHLINE SEE SHEET 2

24" STL
(A00005)

P-7
P-3
Main Valve
Gate 3
Gate 2
Gate 1
P-8A
P-8B
P-2A
P-2B
P-1A
P-1B
P-4
P-5
P-6

VBW11
VBW13
VBW12
VBW9A
VBW9B
VBW10A
VBW10B



NO.	DATE	REVISIONS	APPROVED

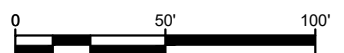

BILL WESSON NAME	WATER OPERATIONS SUPERVISOR	DATE
DANIELLE DRAKE NAME	ASSISTANT ENGINEER	DATE
JACOB MOEDER NAME	IRWD ENGINEERING MANAGER	DATE



DEVELOPED BY ENGINEERING INTERNS:
TINH NGUYEN
RYAN TRAN

SAND CANYON DAM
PIPELINE SCHEMATIC

SHEET
03
03 of 05
149/149 SHEETS

AUGUST 2023

LEGEND

- Main Outlet
- Main Inlet
- Emergency Outlet
- ⊗ Valve Normally Open
- ⊗ Valve Normally Closed
- ⊗ Valve Normally Closed, Emergency Valve to open

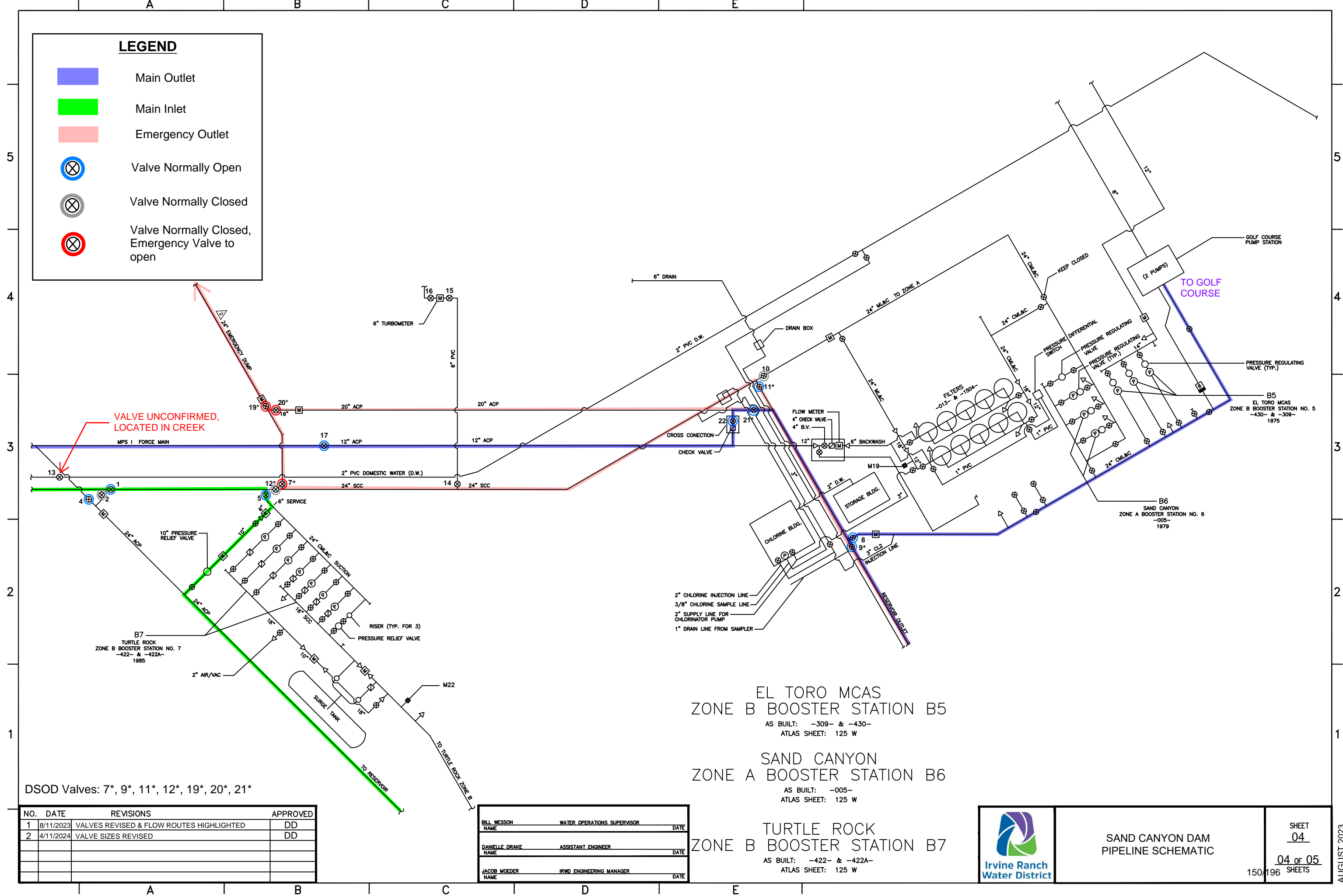

EL TORO MCAS
 ZONE B BOOSTER STATION B5
 AS BUILT: -309- & -430-
 ATLAS SHEET: 125 W

SAND CANYON
 ZONE A BOOSTER STATION B6
 AS BUILT: -005-
 ATLAS SHEET: 125 W

TURTLE ROCK
 ZONE B BOOSTER STATION B7
 AS BUILT: -422- & -422A-
 ATLAS SHEET: 125 W

DSOD Valves: 7*, 9*, 11*, 12*, 19*, 20*, 21*

NO.	DATE	REVISIONS	APPROVED
1	8/11/2023	VALVES REVISED & FLOW ROUTES HIGHLIGHTED	DD
2	4/11/2024	VALVE SIZES REVISED	DD

BILL WESSON	WATER OPERATIONS SUPERVISOR	DATE
DANIELLE DRAKE	ASSISTANT ENGINEER	DATE
JACOB MOEDER	IRWD ENGINEERING MANAGER	DATE



SAND CANYON DAM
 PIPELINE SCHEMATIC

SHEET
04
 04 of 05
 SHEETS

AUGUST 2023

Sand Canyon Dam Valve Summary

Valve Number	Size	Turns	Normally:	Emergency Valve
1	24"		Open	
2	24"		Closed	
4	24"		Open	
5	24"		Open	
7*	24"	41	Closed	Yes
8	24"		Open	
9*	24"	38	Open	
10	24"	45	Closed	
11*	24"	42	Open	
12*	24"		Closed	
17	12"	37	Open	
19*	24"	57	Closed	Yes
20*	20"	32	Closed	Yes
21*	20"		Open	
22	12"		Open	

Sand Canyon Dam Gate Valve Summary

Valve	Turns	Size	Elevation
Main	102	20"	-
Gate 1	48	24"	170'
Gate 2	21	24"	177'
Gate 3	58	24"	185'

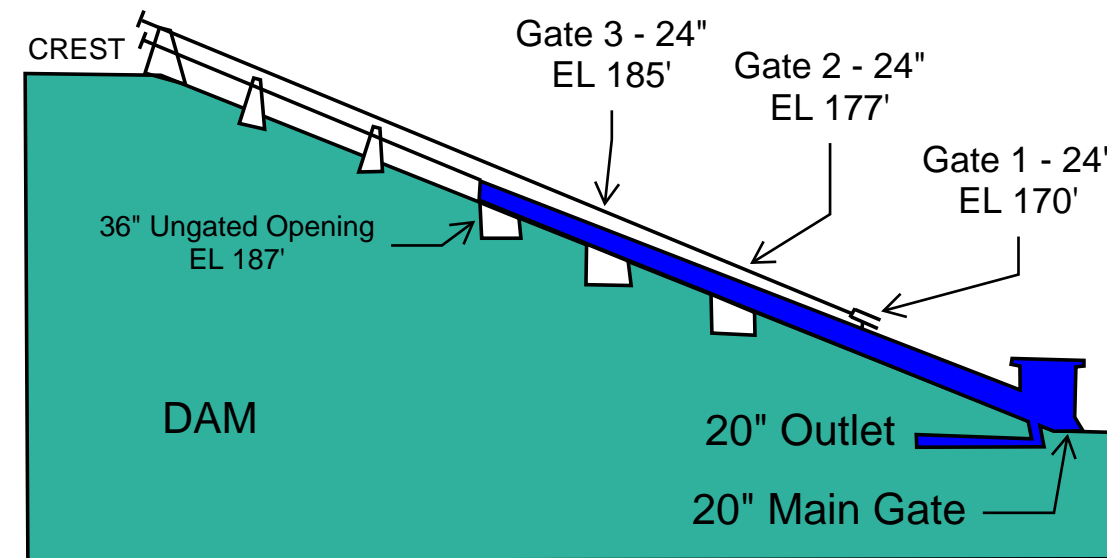

1 SAND CANYON DAM SECTION OF MULTILEVEL OUTLET

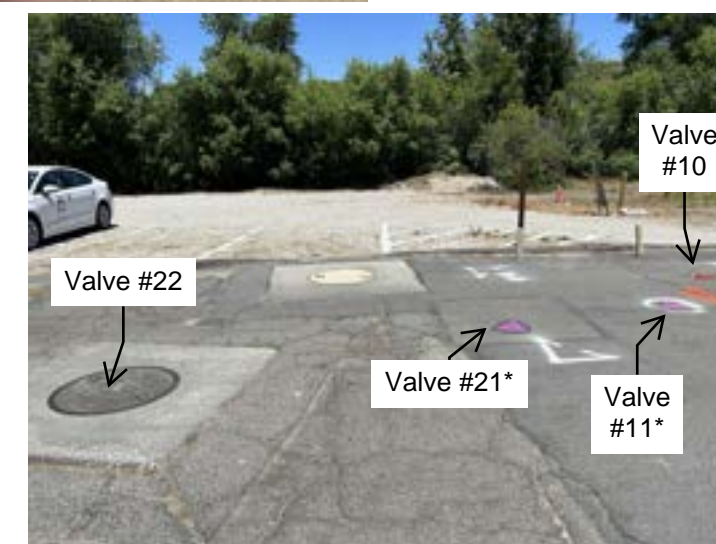
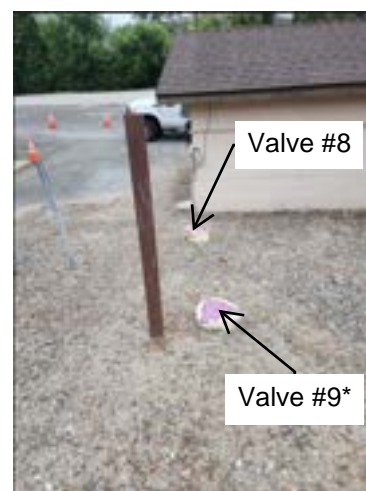

NO.	DATE	REVISIONS	APPROVED
2	4/11/2024	VALVE SIZES REVISED	DD

DSOD Valves: 7*, 9*, 11*, 12*, 19*, 20*, 21*

BILL WESSON	WATER OPERATIONS SUPERVISOR	DATE
DANIELLE DRAKE	ASSISTANT ENGINEER	DATE
JACOB MOEDER	IRWD ENGINEERING MANAGER	DATE

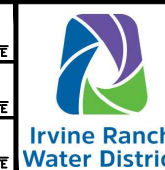

DEVELOPED BY ENGINEERING INTERNS:
TINH NGUYEN
RYAN TRAN

SAND CANYON DAM
PIPELINE SCHEMATIC

SHEET
05
05 of 05
1517 SHEETS

AUGUST 2023

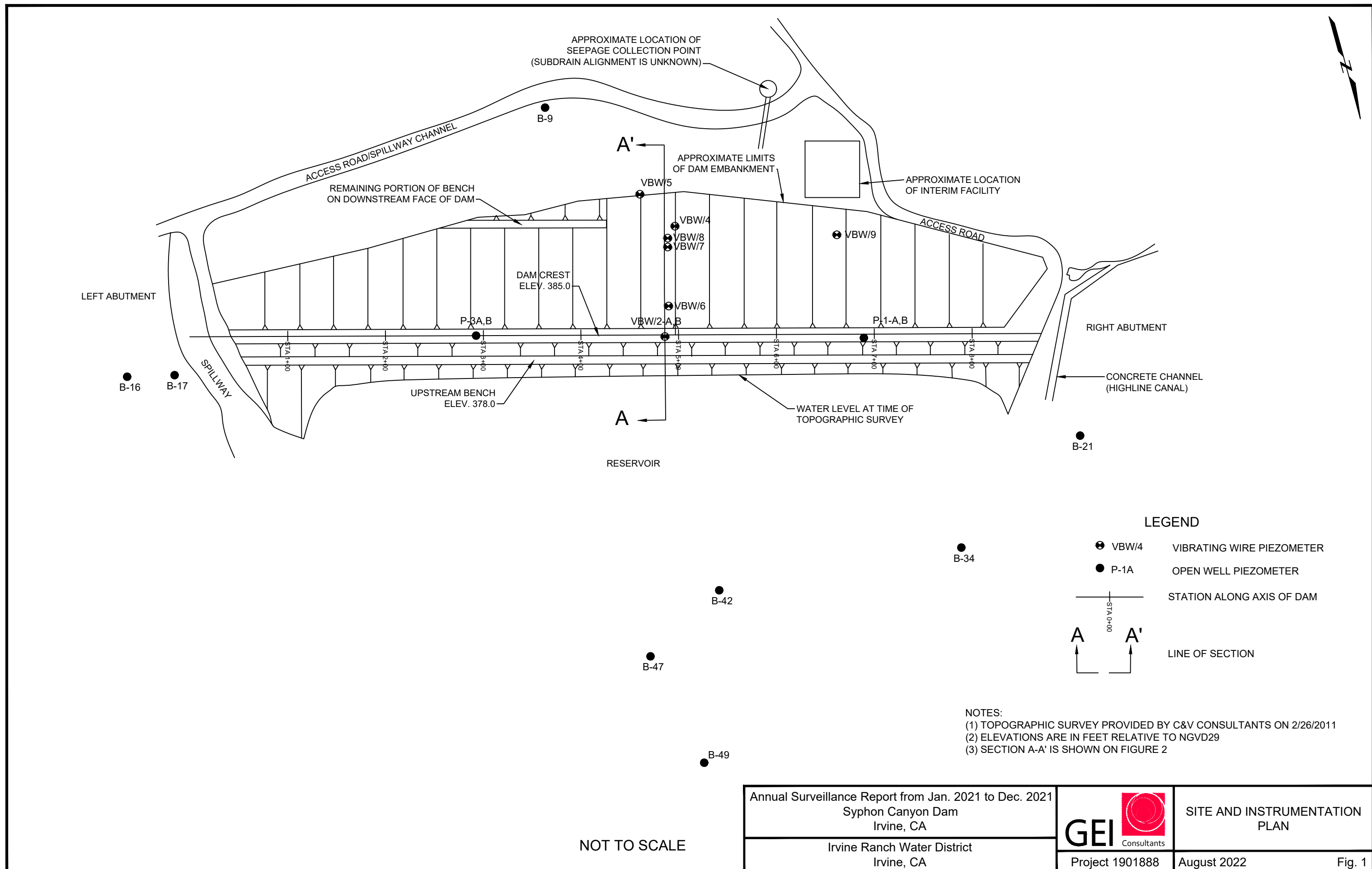

NOT TO SCALE

Annual Surveillance Report from Jan. 2021 to Dec. 2021 Syphon Canyon Dam Irvine, CA		SITE AND INSTRUMENTATION PLAN
Irvine Ranch Water District Irvine, CA		Project 1901888 August 2022

Exhibit 6.3
Location of Critical Valve at Syphon Dam



COORDINATE TABLE		
POINT	NORTHING	EASTING
100	2204461.69	6111143.85
101	2204479.05	6111132.79
102	2204485.68	6111109.30
103	2204508.48	6111108.94
104	2204521.12	6111103.90
105	2204801.74	6110715.15

DIGALERT
CALL TOLL FREE
811
48 HOURS BEFORE YOU DIG
UNDERGROUND SERVICE ALERT OF SOUTHERN CALIFORNIA

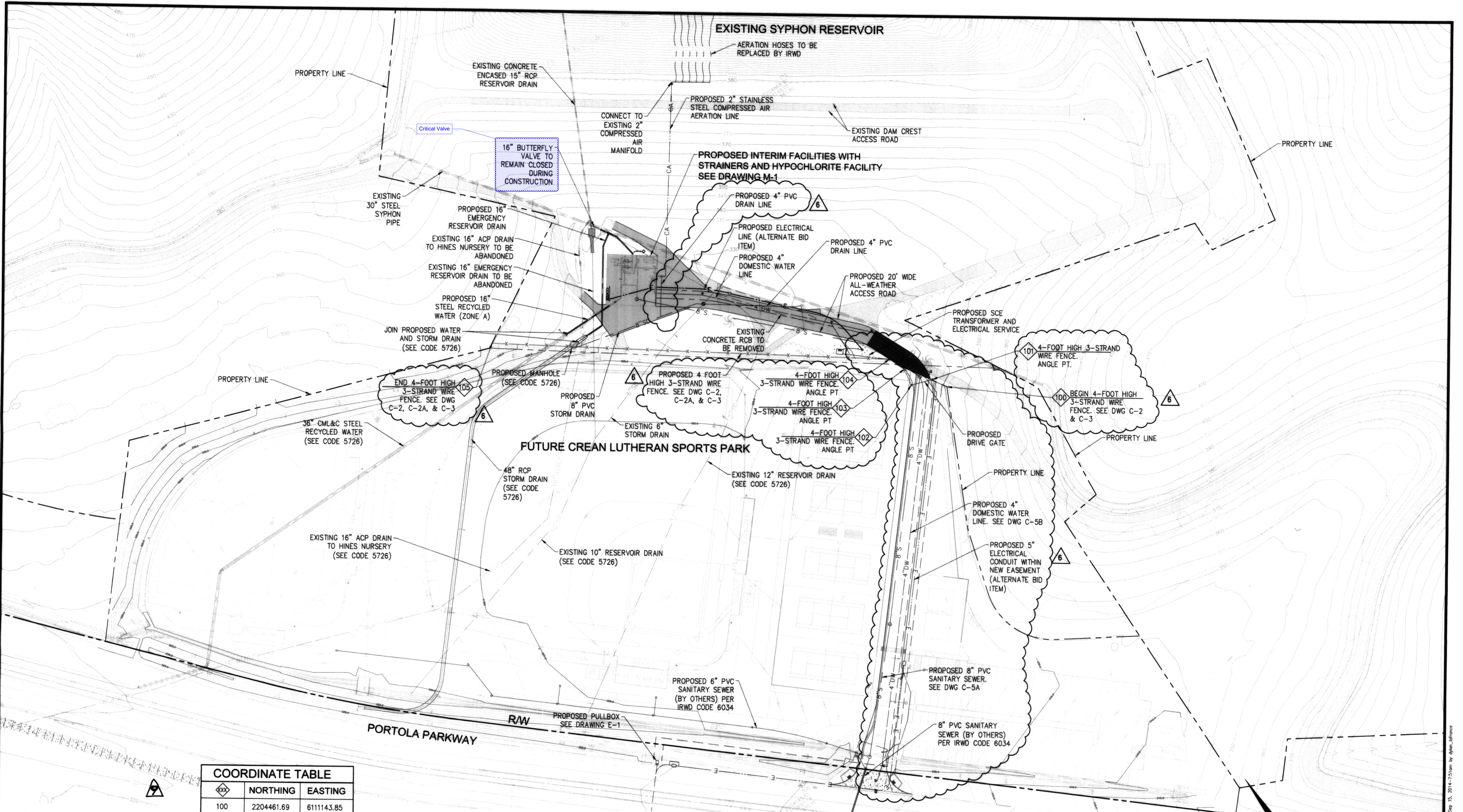
SITE PLAN
SCALE: 1" = 50'

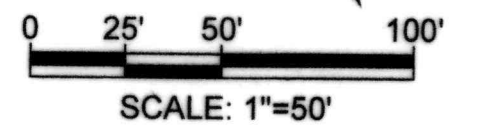

REGISTERED PROFESSIONAL ENGINEER
BRYAN PAINE
No. 43334
Exp. 06/30/15
CIVIL
STATE OF CALIFORNIA

No.	DATE	REVISIONS	APPROVED	DESIGNED: B. PAINE
1	4/18/2013	STRAINER BACKWASH, ROAD, AND PIPING MODIFICATIONS	H. Cuo	
2	6/03/2013	REVISED ACCESS ROAD AND RELATED FACILITIES	H. Cuo	
3	3/07/2014	ACCESS ROAD AND UTILITY RE-ALIGNMENTS	H. Cuo	
4	12/19/14	RECORD DRAWINGS / R. BONDY	H. Cuo	

DRAWN: L. FERRY
CHECKED: B. PYSKA

IRVINE RANCH WATER DISTRICT
Irvine, Calif.



BRYAN PAINE RCE 64334 PROJECT ENGINEER 12/20/12
MALCOLM CORTEZ RCE 52968 PRINCIPAL ENGINEER 12/20/12

SYPHON RESERVOIR INTERIM FACILITIES
PROJECT NUMBER 30374

SITE PLAN

IRWD CODE: 5783

C-1
SHEET 4 OF 34

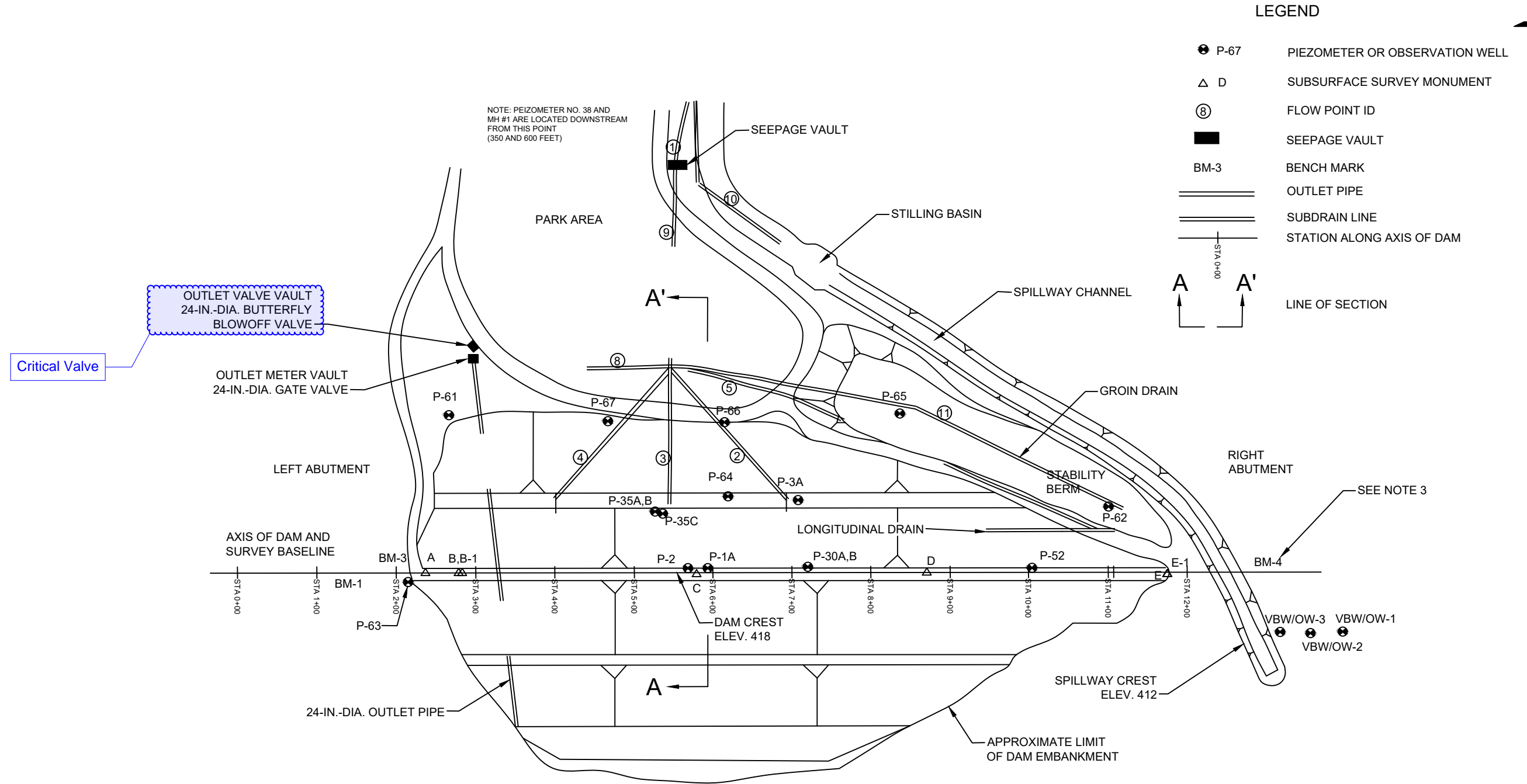

NOTE: PEIZOMETER NO. 38 AND MH #1 ARE LOCATED DOWNSTREAM FROM THIS POINT (350 AND 600 FEET)

LEGEND

- P-67 PIEZOMETER OR OBSERVATION WELL
- △ D SUBSURFACE SURVEY MONUMENT
- ⑧ FLOW POINT ID
- SEEPAGE VAULT
- BM-3 BENCHMARK
- ══ OUTLET PIPE
- ══ SUBDRAIN LINE
- +— STATION ALONG AXIS OF DAM
- A A' LINE OF SECTION

OUTLET VALVE VAULT
24-IN.-DIA. BUTTERFLY
BLOWOFF VALVE

Critical Valve

- NOTES:
1. SECTION A-A' SHOWN ON FIGURE 2
 2. ELEVATIONS ARE IN FEET RELATIVE TO NGVD29
 3. BM-4 WAS DESTROYED BETWEEN 2015 AND 2016. BM-4 WAS RE-ESTABLISHED BY 2018

NOT TO SCALE

Annual Surveillance Report from Jan. 2021 to Dec. 2021 Rattlesnake Canyon Dam and Reservoir Irvine, CA		SITE AND INSTRUMENTATION PLAN
Irvine Ranch Water District Irvine, CA		Project 1901888 August 2022

Fig. 1

Exhibit 6.4
Location of Critical Valve at Rattlesnake Dam

$18 \times 3 = 54$ x 3
 $18 \times 6 = 108$ x 6
 $91 \times 3 = 273$ x 3

NOTE:
 WRAP 30" FLEX COUPLING IN
 10 MILS POLYETHYLENE SLEEVE,
 AND SEAL END WITH 316 TYPE
 STAINLESS STEEL CLAMPS.....
 FILL SLEEVE WITH PETROLEUM
 GREASE.

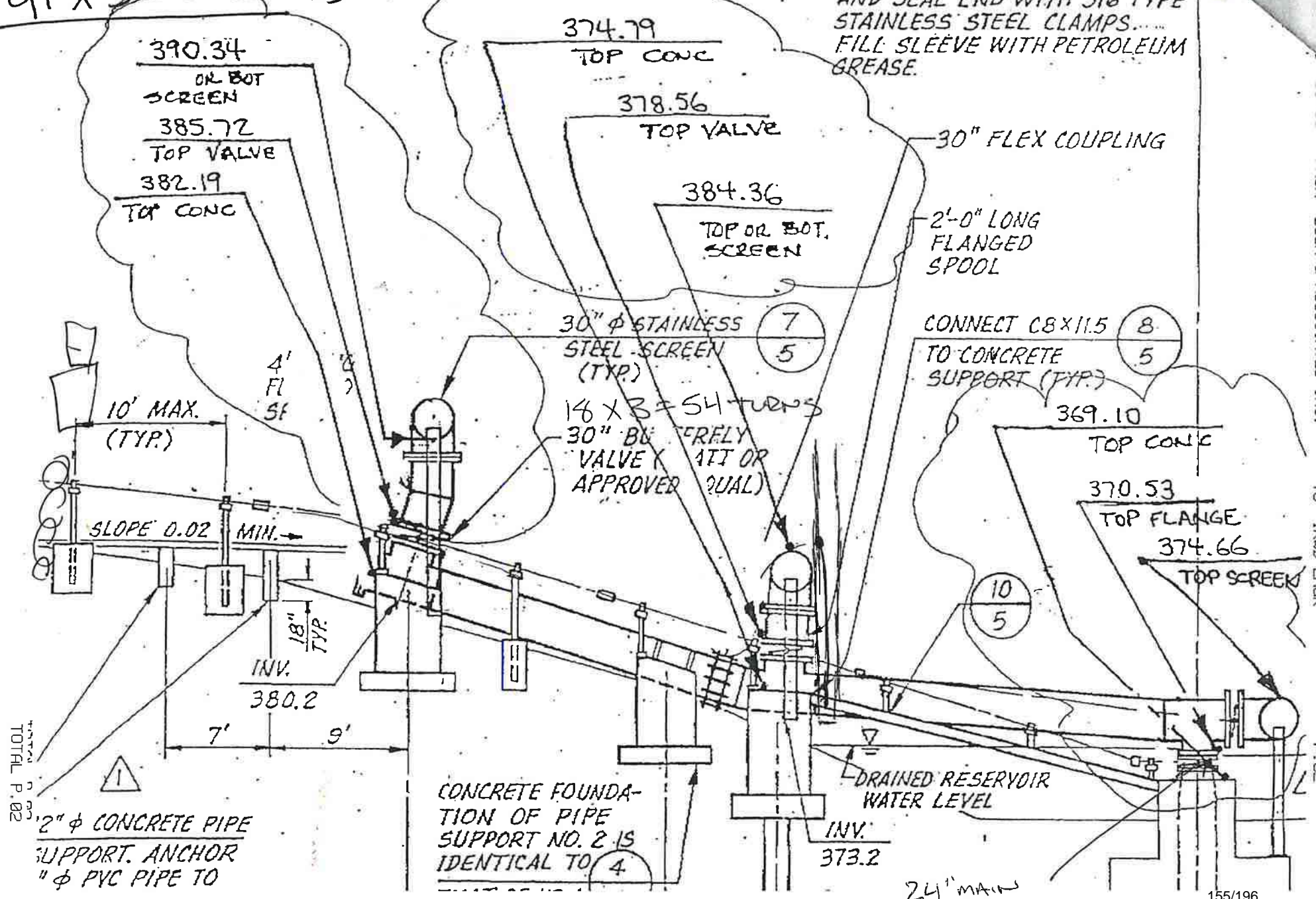

TOTAL P. 02
 2" ϕ CONCRETE PIPE
 SUPPORT. ANCHOR
 " ϕ PVC PIPE TO

09:30 FROM BUSH & ASSOCIATES INC. TO IRAD ENGR P. 02

91 TURNS X 3 = 273 TURNS

Rattlesnake Reservoir Outlet Structure

Location	Valve Size	# Turns	Top Gear Reduction	Total # Turns
Top	30"	18	6 to 1	108
Middle	30"	18	3 to 1	54
Bottom	30"	18	3 to 1	54
Main	24"	91	3 to 1	273

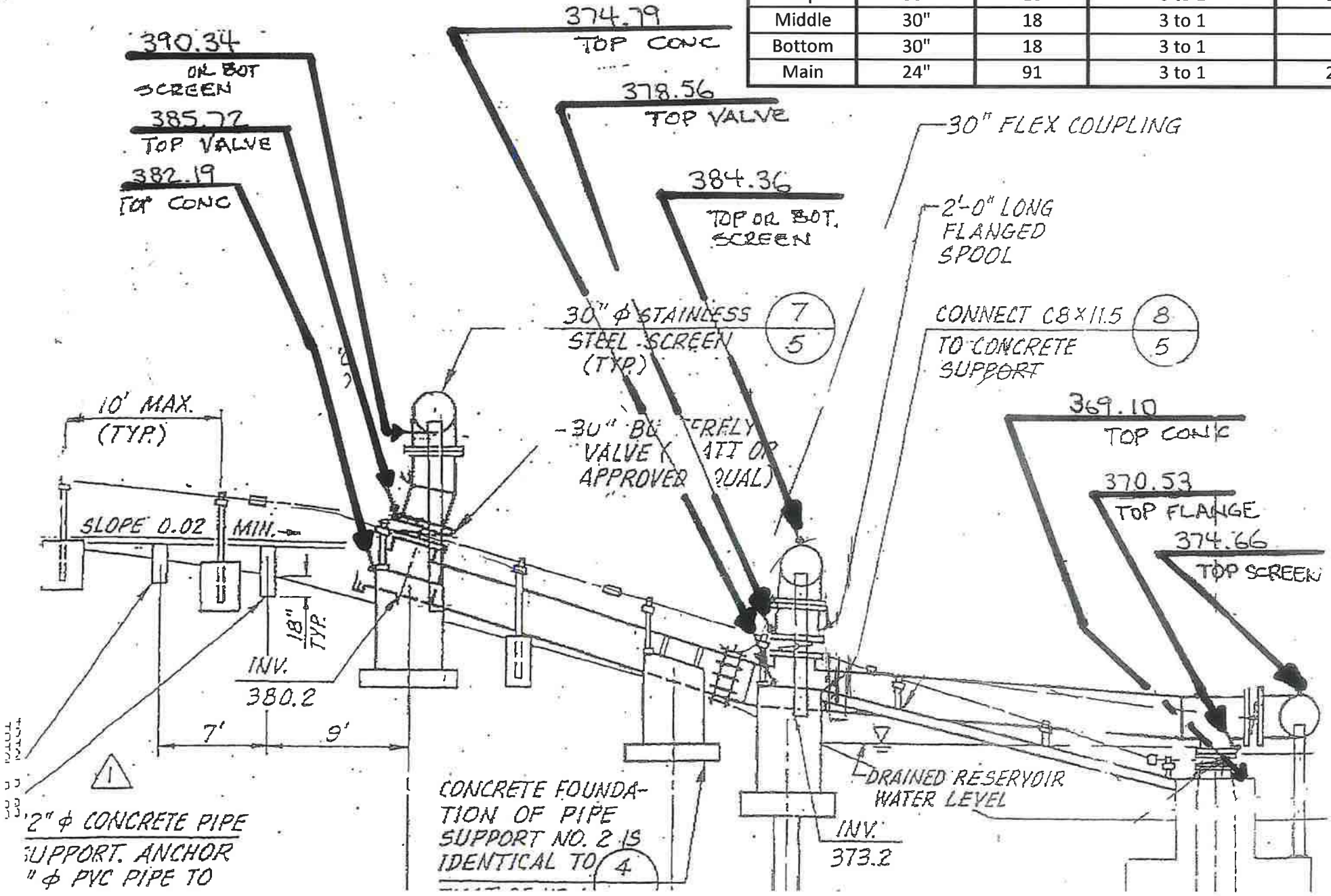

PROPOSED IMPROVEMENTS

- ① 30" FLOW METER ABB WATERMASTER FEW325 SUPPLIED BY DISTRICT
- ② 10' X 9'-10" CONCRETE PAD, 6" THICK WITH #4 @ 12" O.C.
- ③ INSTALL NEW CONDUITS FOR SCADA CONNECTION. SEE ELECTRICAL PLANS FOR NUMBER OF CONDUITS AND SIZE.
- ④ 3" AIR/VACUUM RELIEF VALVE PER DETAIL 3 SHEET 6
- ⑤ 2.88" THICK BLIND FLANGE WITH 2" TAP, EPOXY LINED AND COATED

GENERAL NOTES

1. ALL STEEL FLANGES SHALL BE FLAT FACED ANSI B16.5 CLASS 150 UNLESS OTHERWISE NOTED.
2. ALL STEEL PIPE SHALL HAVE WALL THICKNESS OF 0.312 INCHES.
3. ALL CONNECTIONS BETWEEN DISSIMILAR METALS SHALL BE MADE WITH DIELECTRIC BUSHINGS OR INSULATING FLANGE KITS.
4. MINIMUM TEST PRESSURE = 200 PSI
5. ALL HARDWARE, NUTS, T-BOLTS, AND BOLTS SHALL BE 316SS.
6. ALL BURIED PIPING SHALL BE CMLC AND ALL EXPOSED PIPING SHALL BE PRIMERED AND PAINTED.
7. ALL EXCAVATION AND BACKFILL SHALL BE PER IRWD STD. DWG. W-17.
8. CONTRACTOR RESPONSIBLE FOR ALL MEASUREMENTS AND SHALL VERIFY MEASUREMENTS BEFORE CUTTING PIPE.
9. THE PIPELINE CANNOT BE TAKEN OUT OF SERVICE FOR MORE THAN 105 HOURS. THEREFORE, ALL EQUIPMENT AND MATERIALS SHALL BE ON SITE AND THE LOCATIONS WHERE THE EXISTING PIPE WILL BE CUT EXPOSED TO DETERMINE IF THERE ARE ANY ISSUES.
10. POT HOLE EXISTING 30" OUTLET PIPELINE AT CONNECTIONS FOR LOCATION CONFIRMATION.

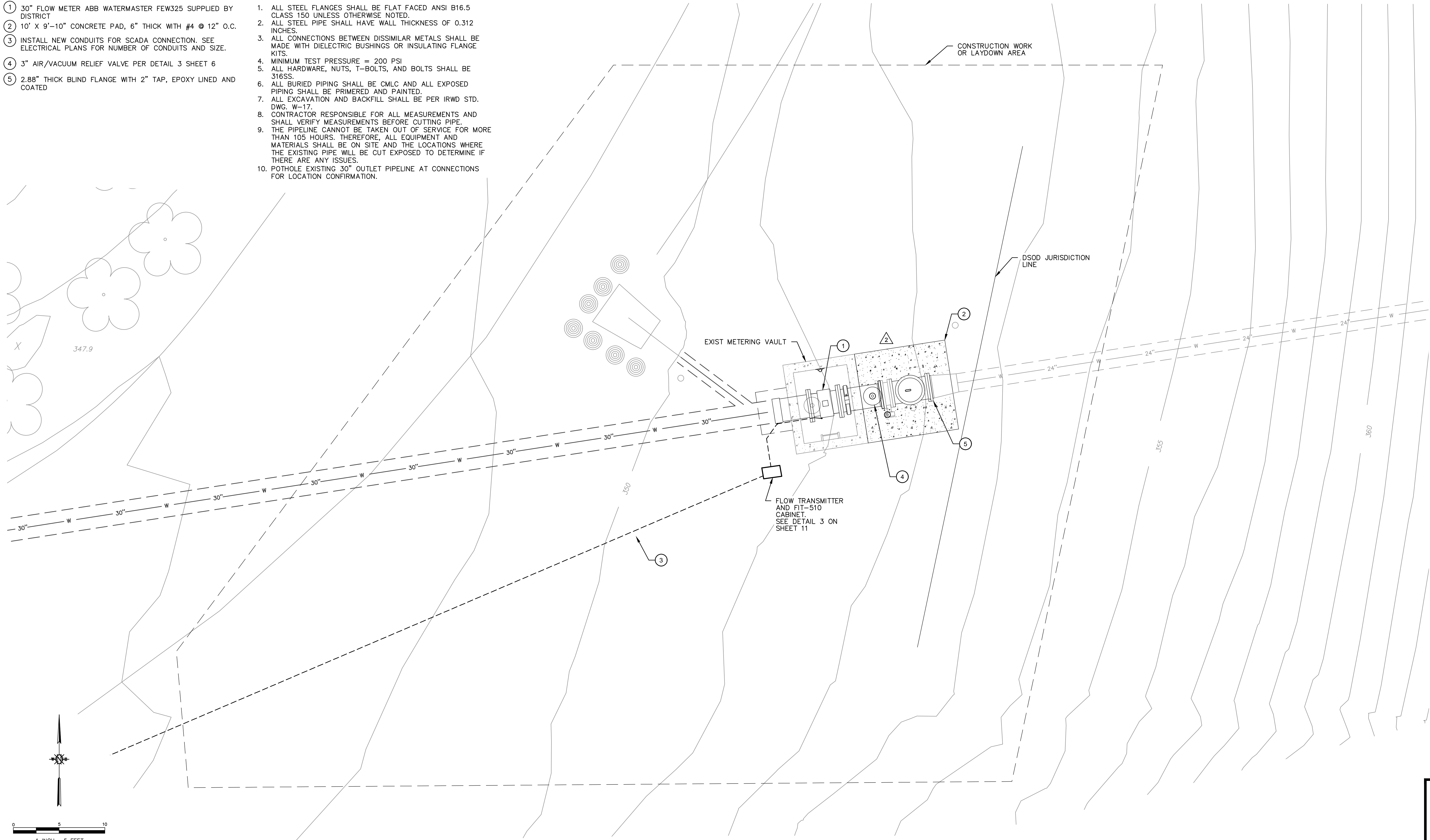

\\cannonassoc.com\DFSroot1\Public\proj\2021\210328\4 Production and Drafting\Const Dwg\CE210328SP0001.dwg 6-14-22 12:25:41 PM lyerf

NO.	DATE	REVISIONS	APPROVED
3	06/16/22	RECORD DRAWINGS	WJ
2	05/04/22	RFI NO. 4	WJ



<i>Gary D. Roepke</i> GARY D. ROEPKE	CONSULTANT PROJECT MANAGER	8/20/2021
<i>Willie S. James</i> WILLIE S. JAMES	IRWD PROJECT MANAGER	8/20/2021
<i>Malcolm A. Cortez</i> MALCOLM A. CORTEZ	IRWD ENGINEERING MANAGER	8/20/2021



IRVINE RANCH WATER DISTRICT
RATTLESNAKE RESERVOIR OUTLET FLOW METER REPLACEMENT
PROJECT NO. 11566

SITE PLAN

SHEET
4
4 OF 11
SHEETS

CODE 7750

RATTLESNAKE RESERVOIR OUTLET FLOW METER REPLACEMENT

AUGUST 2021

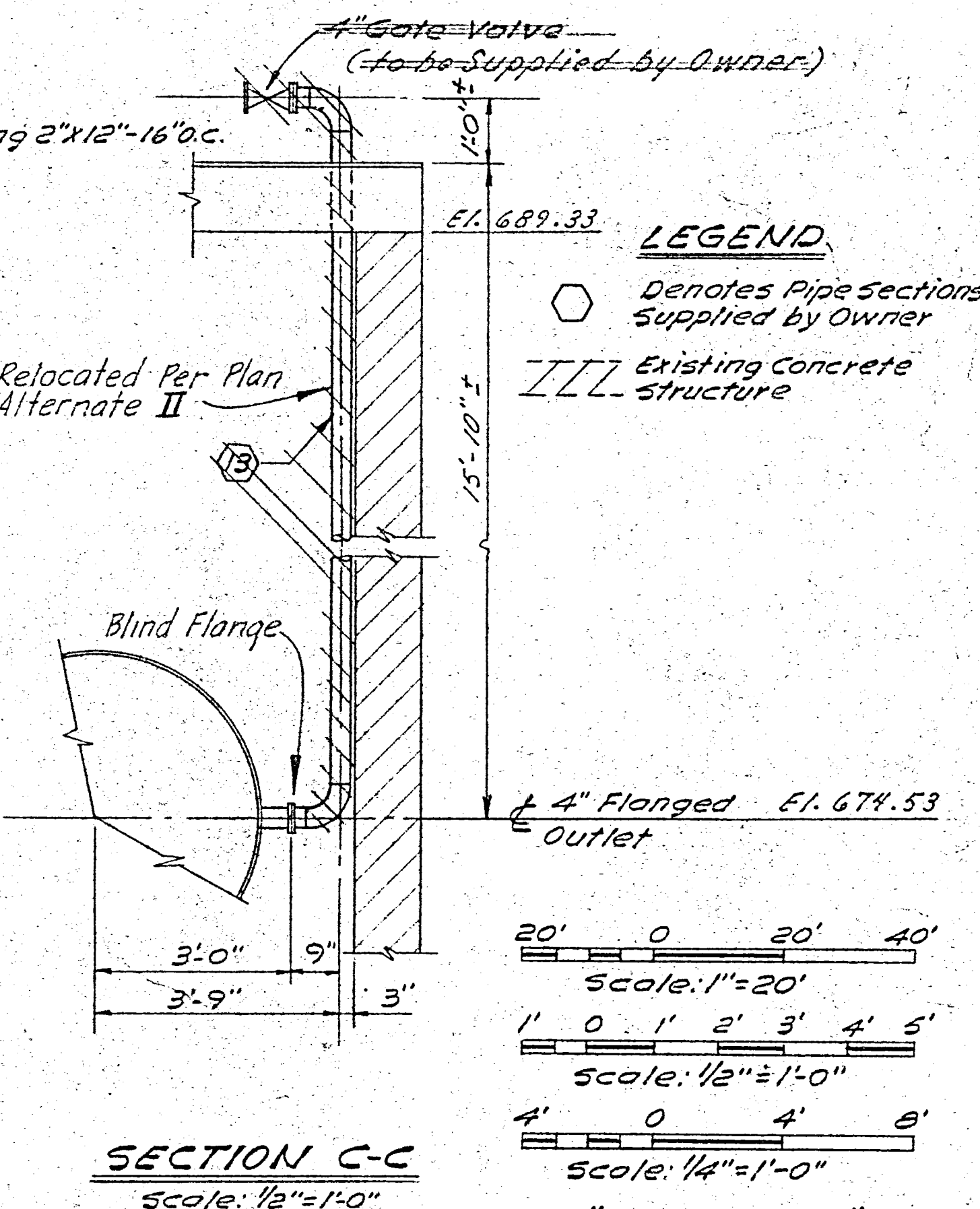
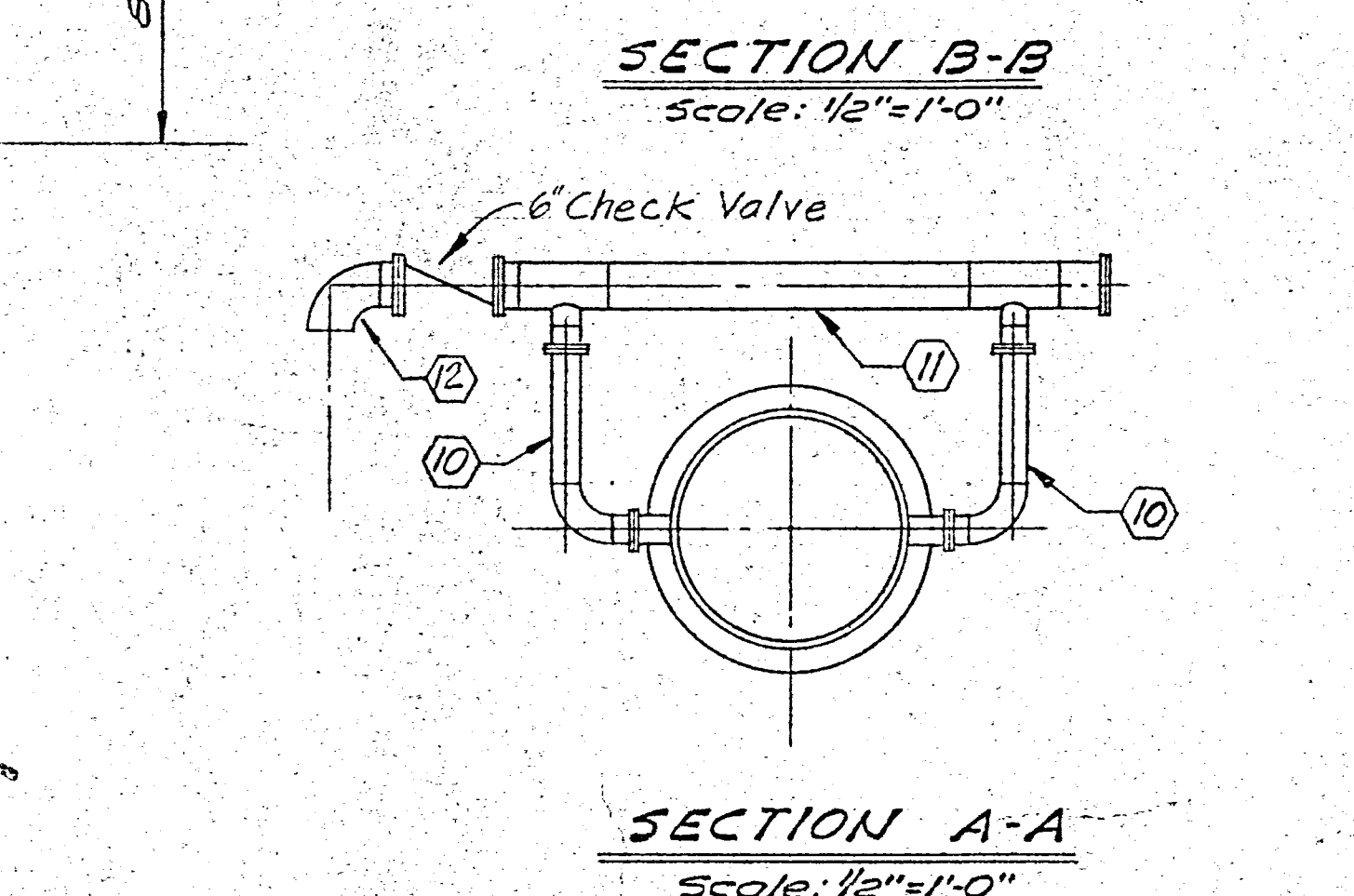
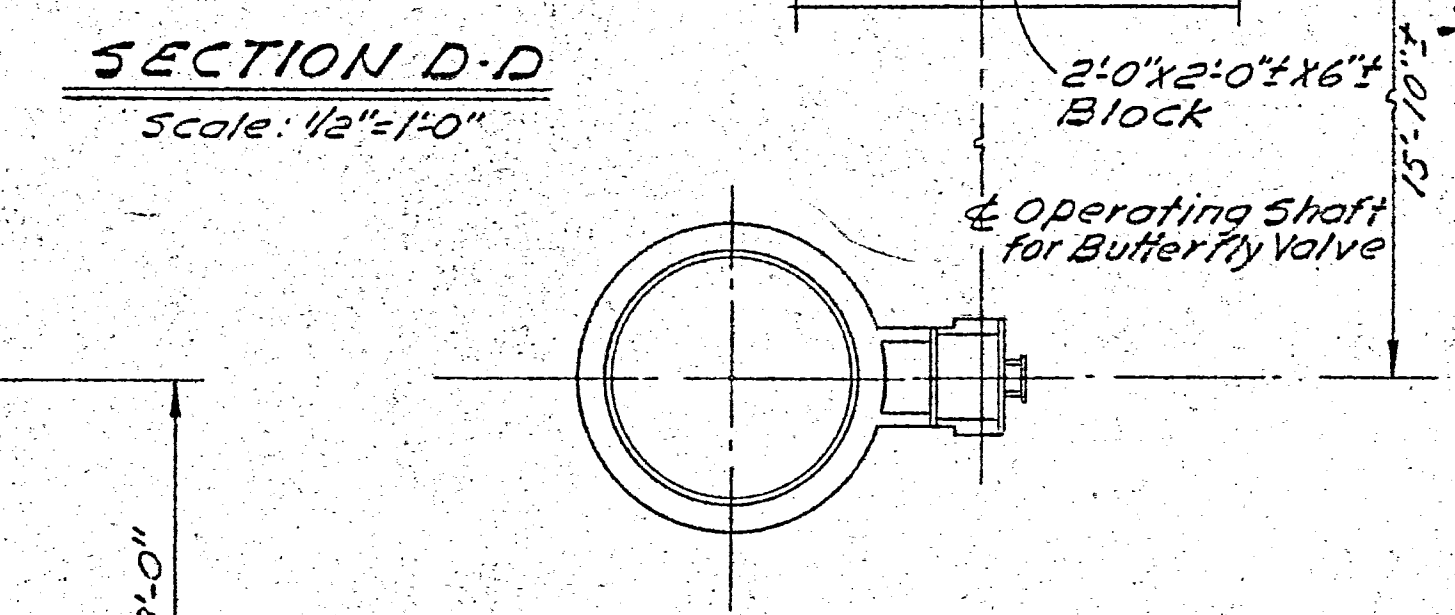
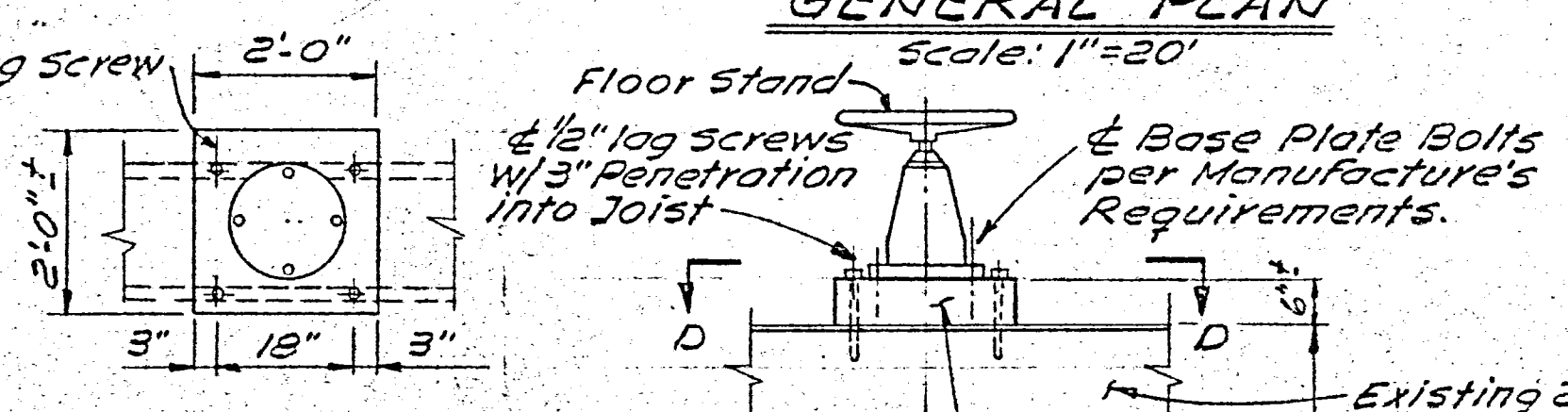
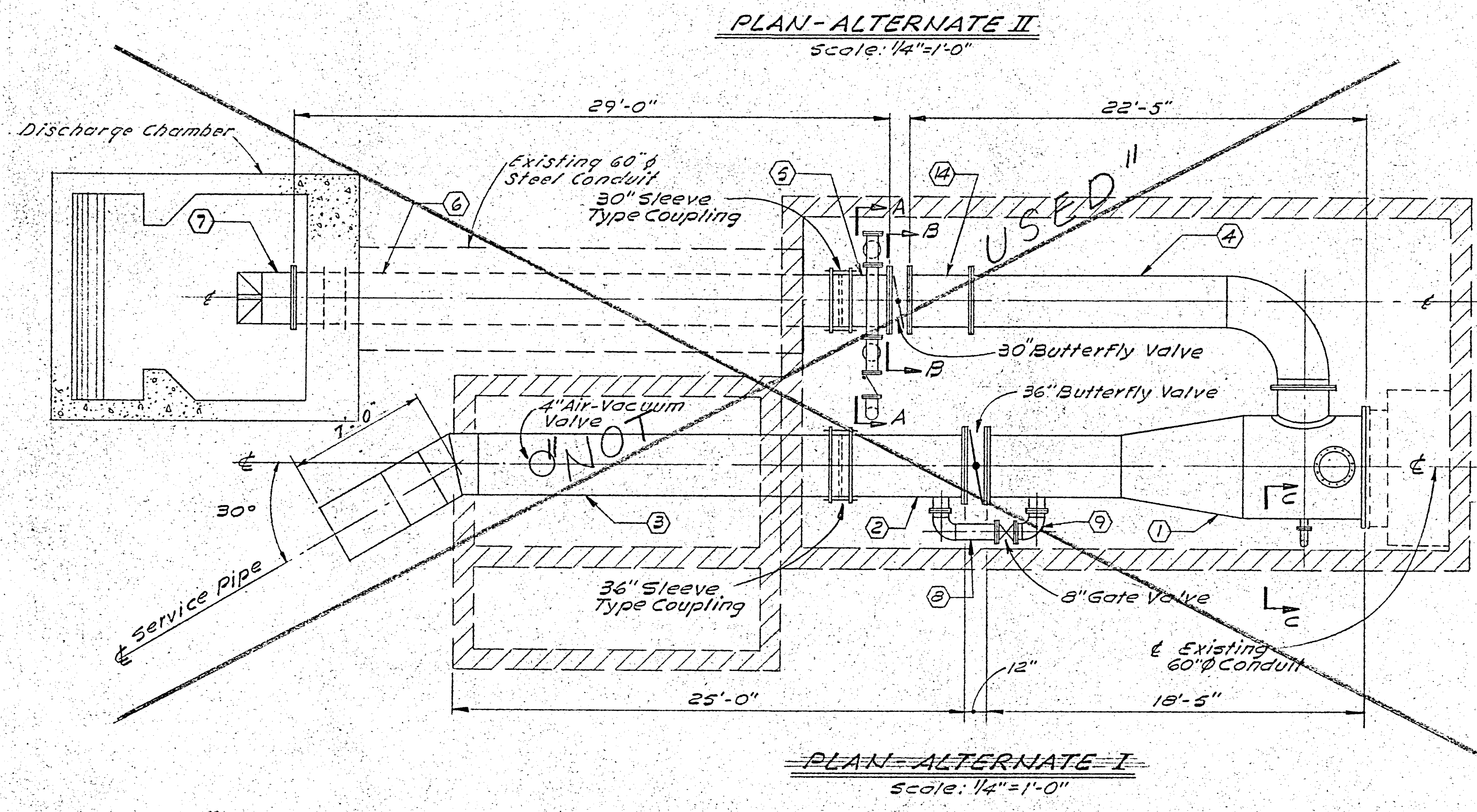
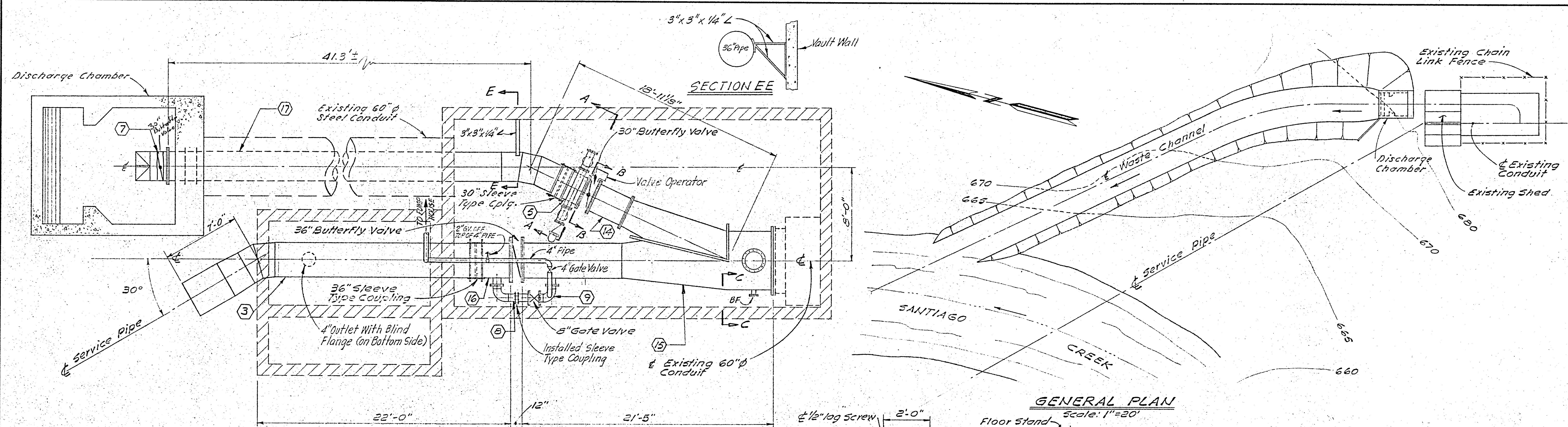

LEGEND
 ○ Denotes Pipe Sections Supplied by Owner
 ▨ Existing Concrete Structure

20' 0 20' 40'
 Scale: 1"=20'
 1' 0 1' 2' 3' 4' 5'
 Scale: 1/2"=1'-0"
 4' 0 4' 8'
 Scale: 1/4"=1'-0"

"AS BUILT"
 MC Number 2-1-70

INITIALS	REVISION	DATE	REV. NO.

LEEDS, HILL AND JEWETT, INC.
 CONSULTING ENGINEERS
 SAN FRANCISCO LOS ANGELES

DESIGNED: *JW*
 RECOMMENDED: *W.A. Brown* 7-18-69 DATE
 DRAWN: *M.P. Perez*
 CHECKED: *A.I. Rogerson*
 APPROVED: *W.A. Brown* 7-29-69 DATE

CARPENTER & SERRANO IRRIGATION DISTRICTS - THE IRVINE CO.
 SANTIAGO CREEK DAM
 OUTLET WORKS RECONSTRUCTION
 GENERAL ARRANGEMENT

JOB No. 202-01
 FILE No. 34
 SERIAL No. F-2482

Exhibit 6.5 Location of Critical Valve at Santiago Creek Dam

NOTE: ALL MATERIALS TO BE STAINLESS STEEL

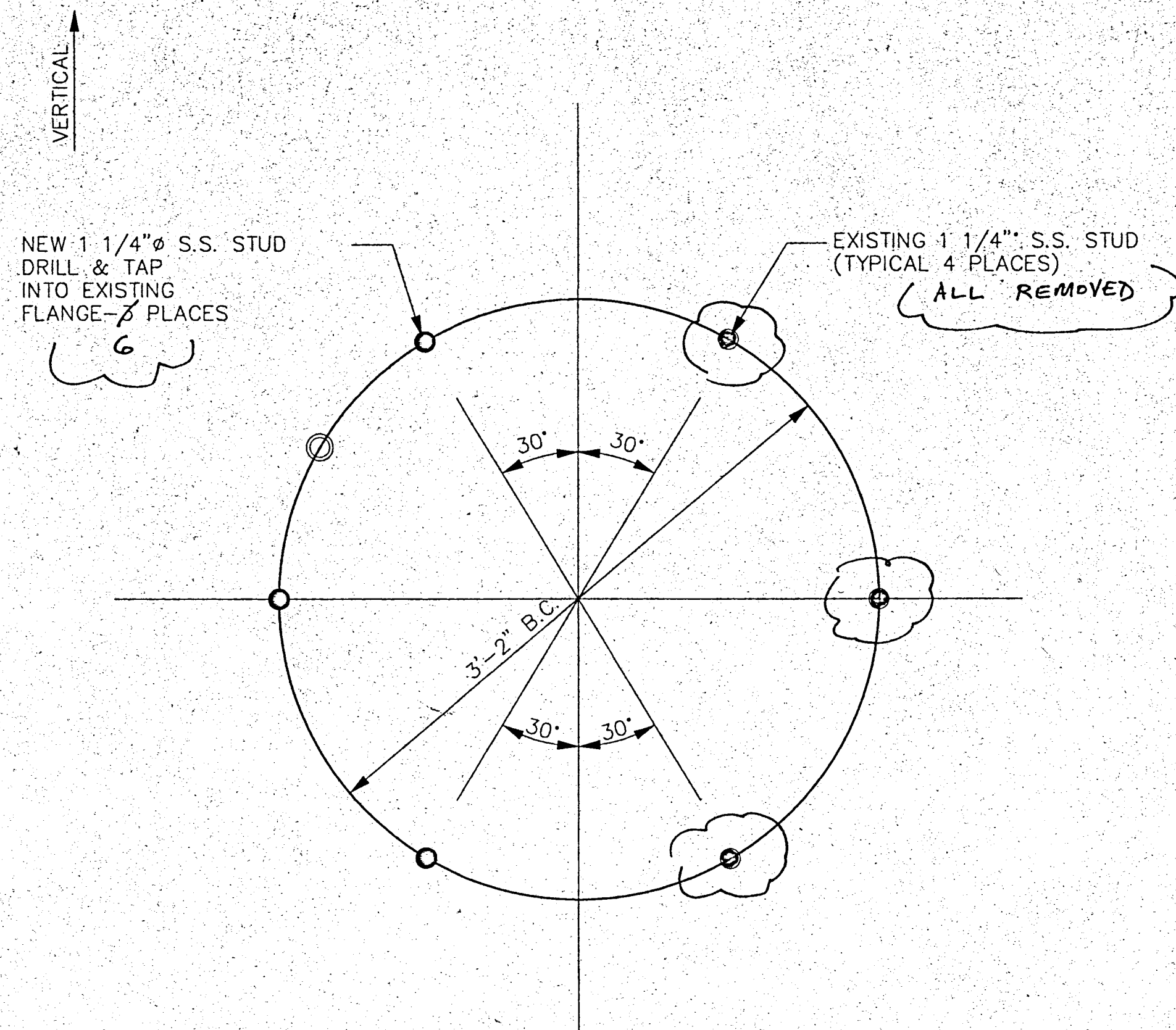
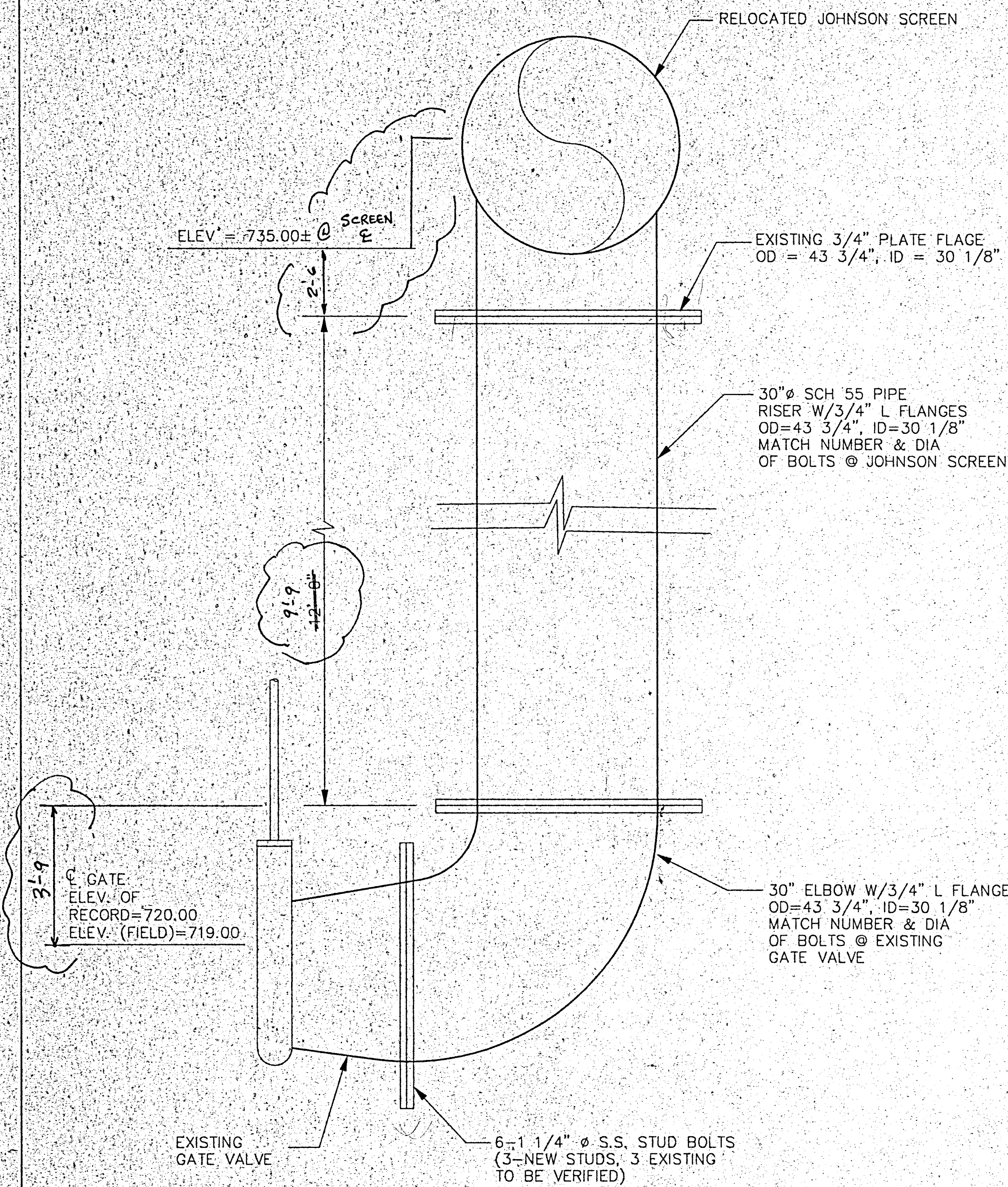

NO EXISTING STUDS WERE RE-USED

- - EXISTING 1 1/4" S.S. STUD TO BE RE-USED
- - NEW 1 1/4" Ø S.S. STUD, DRILL AND TAP
- ⊙ - EXISTING 1 1/4" Ø S.S. STUD - NOT USED

NOTES: VERIFY LOCATION, SIZE & CONDITION OF EXISTING S.S. STUDS PRIOR TO USE.
VERIFY EXISTING FLANGE CONDITION AND ADEQUACY FOR DRILLING & TAPPING OF NEW 1 1/4" Ø S.S. STUDS

**BOLT PATTERN
@ EXISTING FLANGE**

DETAIL

N.T.S.

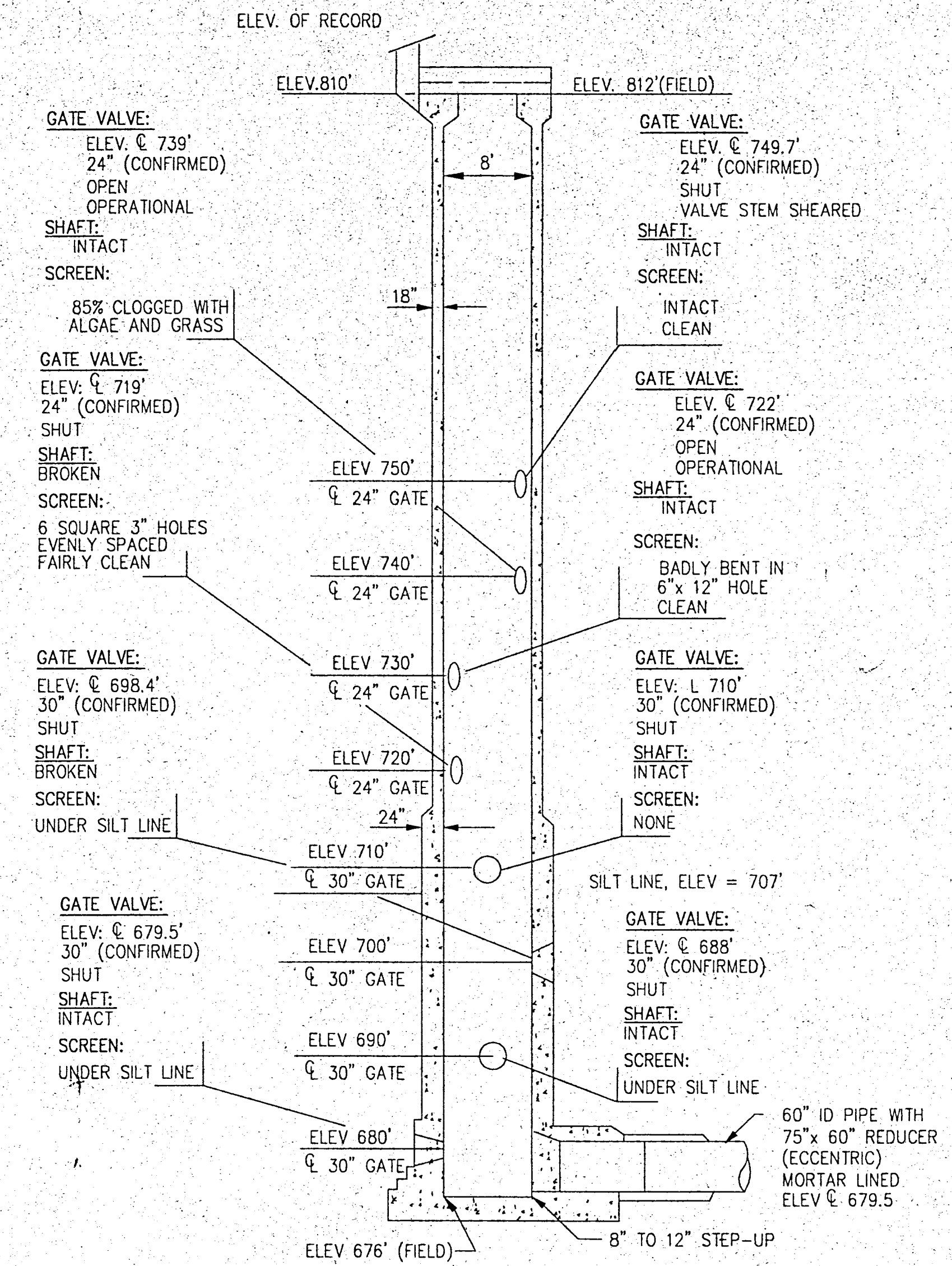

**EXISTING TOWER
(AS BUILT)**

N.T.S.

NOTE: ELEVATIONS OF RECORD OBTAINED FROM AS-BUILT PLANS. ELEVATIONS (FIELD CONFIRMED) PROVIDED BY I.R.W.D.

AS BUILT

RECORD DRAWING
DATE 11-30-01
NO CORRECTIONS
CORRECTIONS AS NOTED

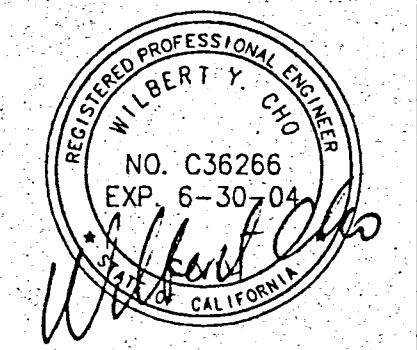

NO.	BY	REVISIONS	DATE	APPROVED	DRAWN	IRVINE RANCH WATER DISTRICT Irvine, California		Wilbert Cho WILBERT Y. CHO RCE NO 36266 PROJECT ENGINEER 6/21/01	Prepared By: CHD DESIGN ASSOCIATES, INC. 3001 REDHILL AVE. Suite 6-206 COSTA MESA, CA 92626	SANTIAGO CREEK DAM-OUTLET TOWER EXTENSION PROJECT NO. 10216 DETAILS	SHEET 3 OF 3	
					IRVINE RANCH WATER DISTRICT							A. TAVAS R. RICE RCE No. 36993 PROJECT ENGINEER 7-2-01
					SCALE AS SHOWN							CARL V. BALLARD DIRECTOR OF WATER OPERATIONS

AS BUILT AS BUILT 75-000



Exhibit 6.5
Location of Critical Valve at Santiago Creek Dam



Discharge to creek from pipeline to Manning Water Treatment Plant



Critical Valve

Pipeline to Manning Water Treatment Plant

Exhibit 6.6
Location of Critical Valve at Harding Canyon Dam

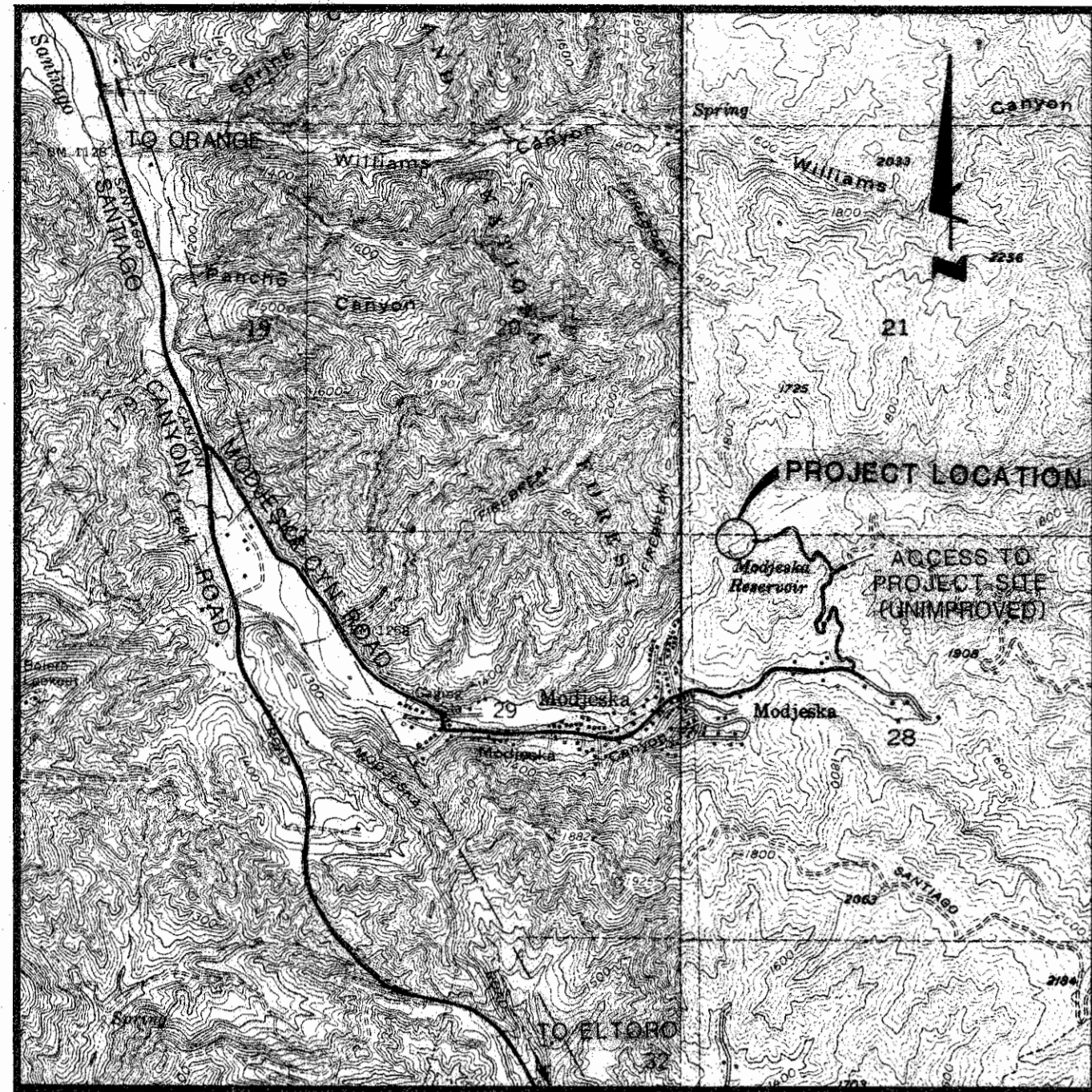

LOCATION MAP
SCALE: 1" = 2000'

GENERAL NOTES:

- A. ALL WORK SHALL BE DONE IN ACCORDANCE WITH THE SPECIFICATIONS AND THIS PLAN
- B. THE CONTRACTOR SHALL BE RESPONSIBLE FOR DEWATERING AND ALL WATER ENCOUNTERED DURING CONSTRUCTION SHALL BE DISPOSED OF IN SUCH MANNER AS WILL NOT DAMAGE PUBLIC OR PRIVATE PROPERTY OR CREATE A NUISANCE OR HEALTH MENACE IN ACCORDANCE WITH SECTION 306-3.3 OF THE "STANDARD SPECIFICATIONS FOR PUBLIC WORKS CONSTRUCTION"
- C. SURPLUS AND ALL MATERIAL REMOVED WHICH IS NOT SUITABLE FOR USE IN THIS PROJECT SHALL BECOME THE PROPERTY OF THE CONTRACTOR AND SHALL BE DISPOSED OF AWAY FROM THE JOBSITE IN A MANNER AND AT A LOCATION ACCEPTABLE TO ALL COGNIZANT AGENCIES

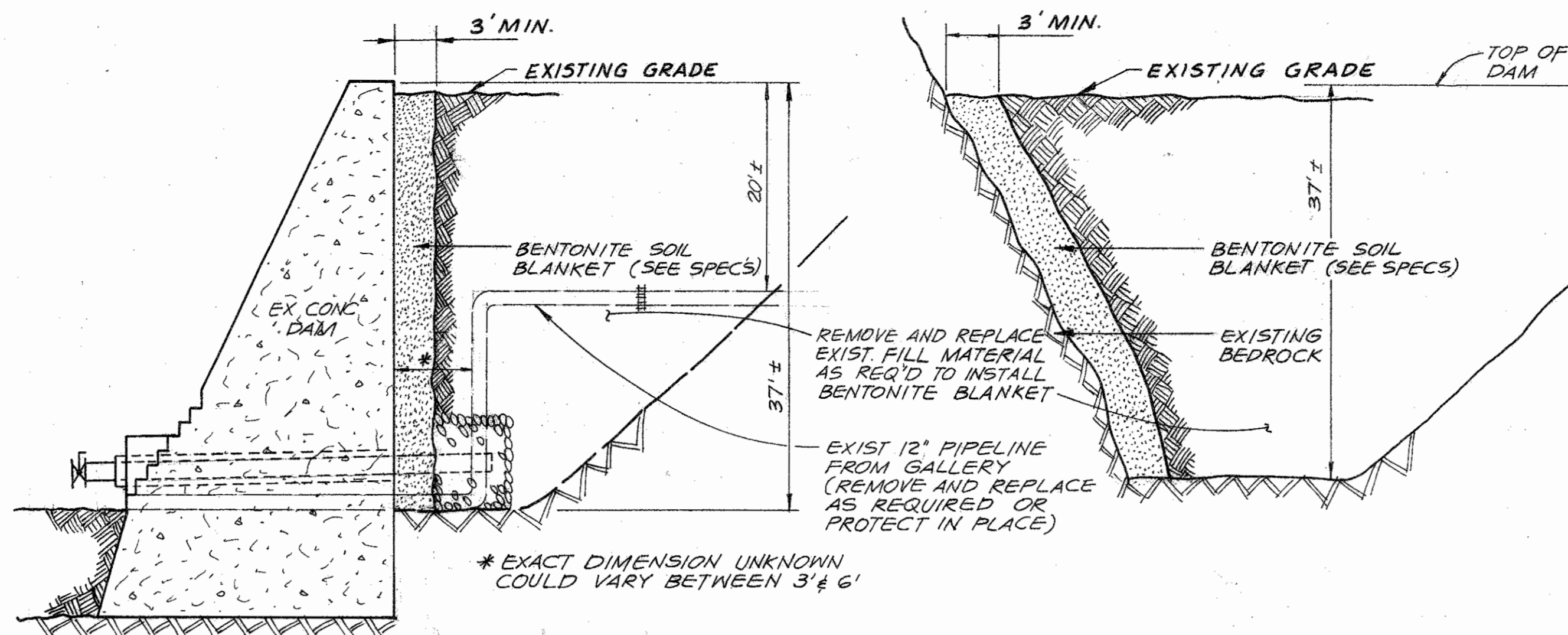

TYPICAL DAM SECTION (A)

TYPICAL ABUTMENT SECTION (B)

LIST OF ITEMS

1. INSTALL APPROXIMATELY 28 L.F. OF 16" DIA. X 1/4" WALL STEEL DRAIN PIPE WITH 1/2" WIDE X 18" LONG SLOTS CUT AT 2" O.C. BULKHEAD END OF DRAIN PIPE WITH 1/2" THICK STEEL PLATE WELDED TO END.
2. REMOVE EXISTING 30" DIA. STEEL PLATE BULKHEAD.
3. INSTALL NEW 30" DIA. X 1/2" THICK STEEL RING PLATE WITH CENTER OPENING TO RECEIVE NEW 16" DIA. STEEL DRAIN PIPE. FULLY WELD RING PLATE TO END OF EXISTING 30" DIA. STEEL PIPE AND TO NEW 16" DIA. STEEL DRAIN PIPE.
4. INSTALL WELDING COMPANION FLANGE TO NEW 16" DIA. STEEL DRAIN LINE AND INSTALL 16" DIA. BUTTERFLY VALVE AND BLIND FLANGE.
5. INSTALL 2" DIA. TAP AND EXTRA-HEAVY STEEL HALF COUPLING (THD'D) WITH 2" DIA. GALV. STEEL PIPE NIPPLE AND 2" DIA. GATE VALVE (NPT).
6. BACKFILL WITH GROUT AFTER INSTALLATION OF 16" DRAIN PIPE IN ACCORDANCE WITH THE REQUIREMENTS OF SEC. 306-3.7 OF THE "STANDARD SPECIFICATIONS FOR PUBLIC WORKS CONSTRUCTION".
7. INSTALL 8 CU. YARDS MINIMUM OF NO. 2 AGGREGATE MEETING THE REQUIREMENTS OF SECTION 200-1.4 OF THE "STANDARD SPECIFICATIONS FOR PUBLIC WORKS CONSTRUCTION".

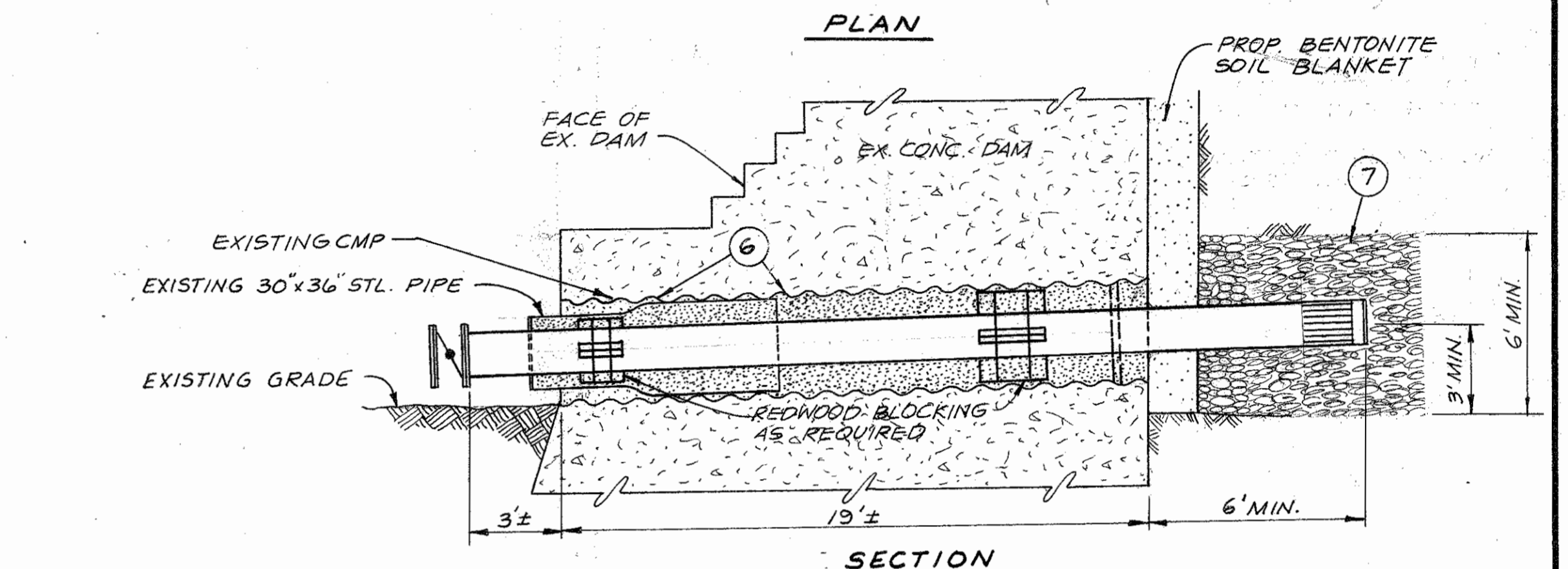
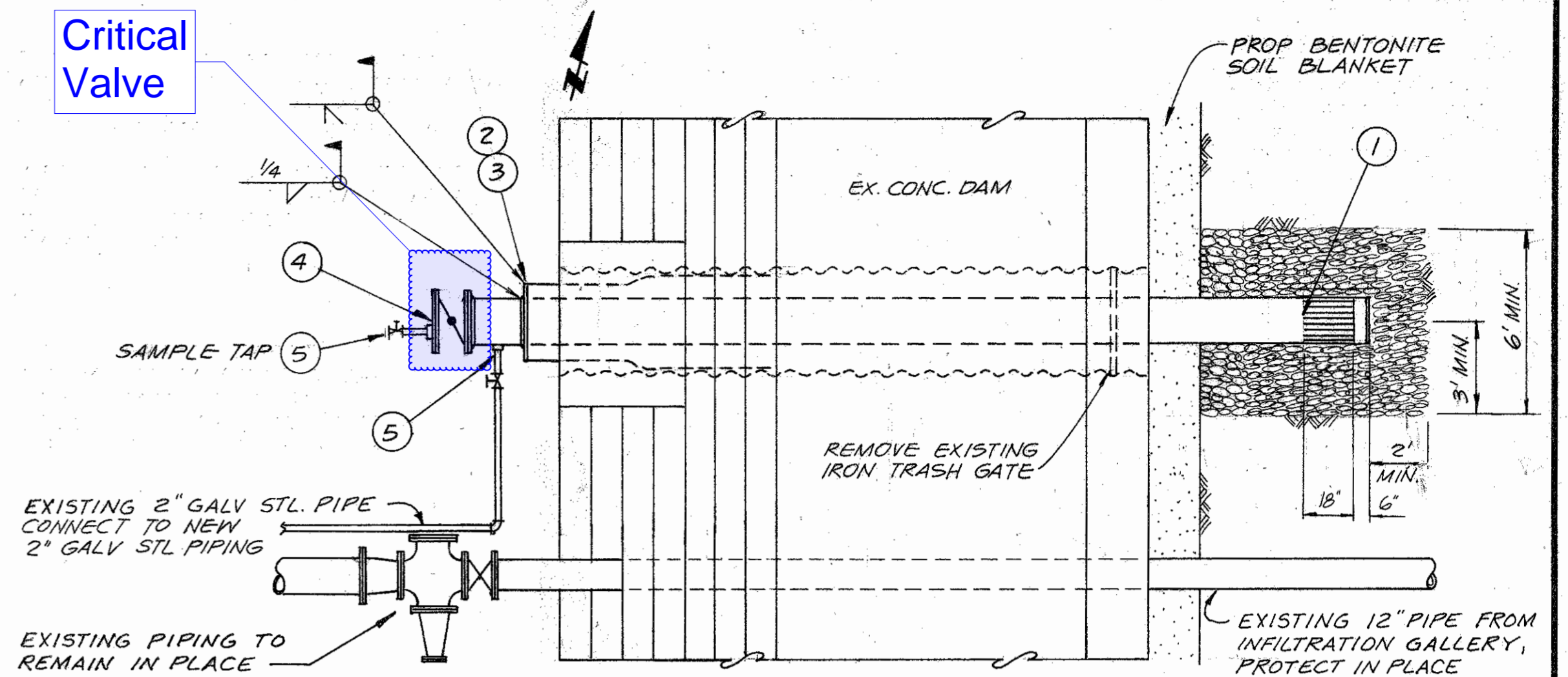

DRAIN PIPING DETAIL (1)

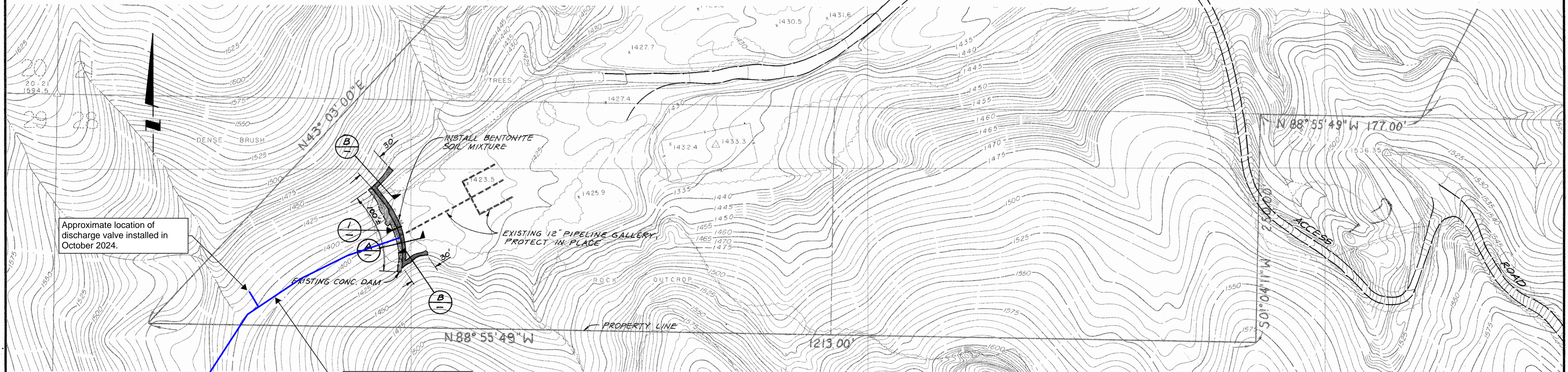

SITE PLAN
SCALE: 1" = 50'

Approximate location of discharge valve installed in October 2024.

Diagrammatic representation of pipeline to Manning Water Treatment Plant

SUBMITTED.		
Michael Padana	32135	5/20/05
PROJECT ENGINEER	R.C.E.	DATE
RECOMMENDED.		
H. D. Mishra	16371	5/28/05
PROJECT MANAGER	R.C.E.	DATE



Robert Bein, William Frost & Associates
PROFESSIONAL ENVIRONMENTAL ENGINEERS & PLANNERS
P.O. BOX 2390 • 1401 QUAIL STREET, NEWPORT BEACH, CALIFORNIA 92663
(714) 833-0070

DATE	BY	DESCRIPTION	APP'D.	DATE
REVISIONS				

APPROVED	
Charles Con	
DISTRICT MANAGER	
DATE May 28, 1985	
FIELD BOOK	SCALE AS NOTED
DESIGNED RKE	DRAWN RKE
CHECKED JRB	DATE 4-9-85

HARDING CANYON DAM IMPROVEMENTS

INSTALLATION OF BENTONITE BLANKET AND REPLACEMENT OF DRAIN PIPING

SANTIAGO COUNTY WATER DISTRICT

SHEET

1

OF

22367

W-8 A01968

**Dam Safety Program
Guideline No. 8
Emergency Preparedness and Planning**

1.0 Purpose

The purpose of this document is to provide guidance for Emergency Preparedness and Planning as it relates to IRWD’s Dam Safety Program (DSP).

2.0 Background

A dam safety incident is an impending or actual sudden uncontrolled release or excessive controlled release of water from an impounding structure. The release may be caused by damage to or failure of the structure, flood conditions unrelated to failure, or any condition that may affect the safe operation of the dam. The release of water may or may not endanger human life, downstream property, or the operation of the structure. When people live in an area that could be affected by the operation or failure of a dam, there is the potential for an emergency related to a dam safety incident. FEMA defines an emergency as “Any incident, whether natural, technological, or human-caused, that requires responsive action to protect life or property.”

IRWD has Dam Emergency Action Plans (EAP) for each of its five Extremely High Hazard dams. The purpose of the EAP’s is to outline an emergency response associated with the dam, facilitate notification of affected parties, assign roles and responsibilities to involved agencies, and take mitigating actions in time to minimize loss of human life or injury and property damage. These situations include, but are not limited to dam instability, sizable earthquakes, extreme storm events, major spillway releases, overtopping of the dam, outlet system failure, abnormal instrument readings, vandalism or sabotage, spillway or gate failures, and failure of the dam.

3.0 Dam Emergency Action Plan (EAP)

Table 1 below is a summary of IRWD’s EAP’s and the date that the California Office of Emergency Services (CalOES) approved the original EAP. Inundation maps are a core component of the EAP as they identify the population downstream that may be impacted in the event of an emergency. CalOES requires that the inundation maps are updated a minimum of every 10 years, or sooner if there are significant changes to development downstream or modifications to the dam that impact the storage capacity.

Table 1: Summary of IRWD’s EAPs		
Dam	Original CalOES Approval Date	Date of Approved Inundation Map
San Joaquin	March 7, 2021	February 2, 2018
Sand Canyon	April 21, 2020	June 12, 2018
Syphon	March 5, 2021	October 9, 2018
Rattlesnake	March 5, 2021	November 7, 2018
Santiago Creek	March 12, 2021	January 26, 2018

**Dam Safety Program
Guideline No. 8
Emergency Preparedness and Planning**

In addition to EAP's, IRWD has, and may develop, response plans to address specific items. The response plans may cover scenarios such as, but not limited to, the following.

- Determining when to operate the emergency blowoff to lower the reservoir
- Backup plan for critical pieces of equipment that become inoperable
- Actions to take and people to notify in the event the emergency spillway is activated

Both the EAP and response plans are part of IRWD's overall DSP. Separate from EAP's and response plans, IRWD maintains an Emergency Operation Plan (EOP), which guides staff internal to IRWD to effectively manage response and recovery.

4.0 Responsibility

Various staff are responsible for developing, maintaining, updating, and ensuring fluency of the EAPs and emergency response plans. Table 2 summarizes the responsibility of staff associated with Emergency Preparedness and Planning.

Table 2: Summary of Emergency Preparedness and Planning Responsibilities	
Description of Responsibility	Responsible Party
Maintain, update, and ensure plan holders and internal staff are knowledgeable on the contents of the Dam EAP's	Director of Safety & Security
Maintain, update, and ensure staff are trained on the Emergency Operations Plan (EOP)	Director of Safety & Security
Ensure EAP is distributed and accessible to IRWD staff and Plan Holders	Director of Safety & Security
Maintaining and update inundation maps	Dam Safety Engineer
Participate in EAP training	Director of Safety & Security, Dam Safety Engineer, Dam Safety Program Staff, Water Operations Staff, Standby Staff
Prepare, maintain, and distribute response plans	Dam Safety Engineer
Identify critical pieces of equipment that may require response plans	Director of Maintenance, Dam Safety Engineer

5.0 References

- 5.1 California Government Code Section 8589.5(c)
- 5.2 IRWD Emergency Operations Plan, September 2020

1.0 Purpose

The purpose of this document is to provide guidance for non-routine activities in IRWD's Dam Safety Program (DSP).

2.0 Background

Non-routine dam safety activities occur throughout the normal course of owning and operating dams. Non-routine dam safety activities may include items that potentially change or could change the dam safety risk such as, but not limited to, the following.

- Landslides around the reservoir or at the dam
- Earthquakes
- Re-evaluation based on changed conditions, standards, or practices
- Unexpected or uncharacteristic readings from monitoring data
- Visual change in dam (e.g., observed seepage, cracks, etc)
- Proposed improvements adjacent to dam
- Change in mechanical performance

Results from routine dam safety activities could trigger non-routine dam safety activities. To streamline the review process and promote clear lines of responsibility, it is necessary to identify the roles and responsibilities for non-routine activities.

3.0 Guidelines for Non-Routine Activities

3.1 Consideration for Dam Safety Risk Triggers

The Dam Safety Engineer, in collaboration with program staff, executive management, and Dam Engineering Consultant as needed, will have responsibility for determining if presented information is a trigger for dam safety risk. If it is a trigger, then consideration for a dam safety issue should be made. The consideration should utilize risk to inform the assessment.

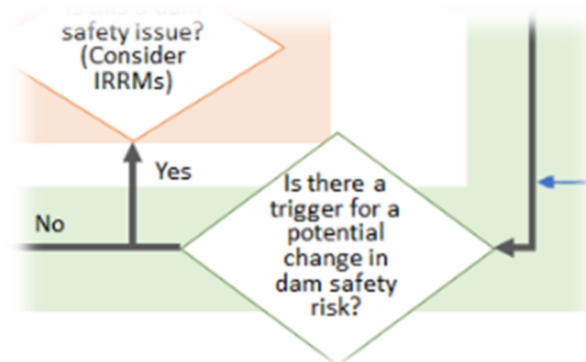

3.2 Consideration for Dam Safety Issue

The Dam Safety Engineer is responsible for coordinating a determination if the triggering event is a dam safety issue. Consideration of dam safety issue will often involve the input from the Dam Engineering Consultant. The coordinated determination will be communicated with executive management. Depending on the issue and perceived risk, the item may be elevated to the General Manager to contribute to the decision, but at a minimum the General Manager would be made aware of the outcome. For more significant decisions, such as implementing risk reduction measures, or to highlight the urgency, the item may be brought to the attention of the Board for review and acceptance.

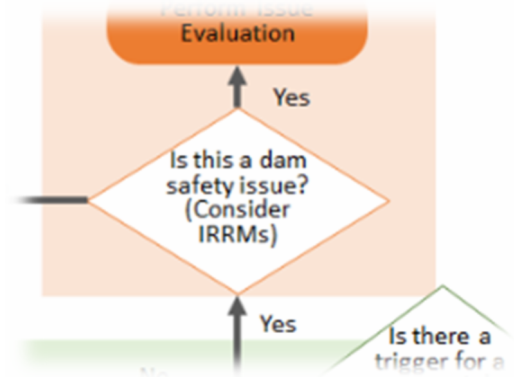

3.3 Perform Issue Evaluation

Issue Evaluation Studies (IES) are non-routine activities that are triggered when a significant change in loading, Periodic Dam Safety Review (PDSR) risk evaluation, or performance condition occurs. Under these conditions, it may be necessary to perform a study that is more detailed than the routine activities. The type of risk analyses used to support IES's may vary and may be phased to make basic decisions (e.g. whether to perform field investigations or engineering analyses) and working towards more detailed and comprehensive risk analysis if more critical decisions (e.g. whether risk is tolerable and whether risk reduction actions are justified).

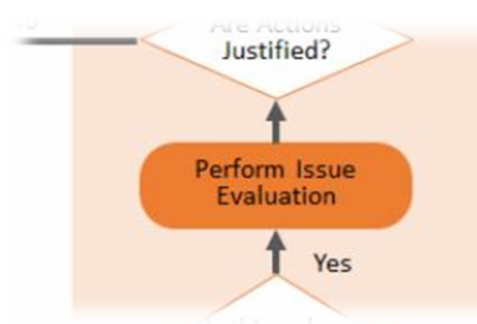

The Dam Safety Engineer is responsible for retaining the services of a Dam Engineering Consultant to conduct an Issue Evaluation Study (IES), when needed, to further understand if a dam safety issue exists, the extents of the concern, and offer recommendations. The IES should consider the Potential Failure Modes (PFM) that contribute to the dam safety issue, and where appropriate, risk analysis for the PFM based on findings in the IES. The risk analysis may take on a variety of forms including quantitative and qualitative.

3.4 Determining if Actions are Justified

The PDSR will identify the risk analysis and assessment for IRWD’s dam portfolio and offer recommendations for decision making to control risk. Separate from the PDSR, specific incidents may arise, or specific studies may occur, that prompt the need to estimate and evaluate risks. In all cases, the risk estimating process will be completed utilizing DSP Guideline No. 10, Periodic Dam Safety Review, where a quantitative method of analysis is warranted. The risk estimates will incorporate information received from the Issue Evaluation Study and be evaluated on the risk matrix to understand the estimated risk in relation to tolerable risks, national average failure likelihood, and other risks in IRWD’s dam portfolio.



In general, the Dam Safety Engineer will present the risk estimates to the Executive Director of Technical Services, General Manager, and/or the Board for decision making based on the value of the improvements and in accordance with IRWD’s procurement policy. Several factors may be considered when making risk informed decisions including, but not limited to the following.

- Estimated risk
- Cost relative to the overall benefit
- Priority of the work relative to other dam improvements
- Available staff resources
- Environmental impacts
- Economic impacts
- Operational impacts
- Practicableness

4.0 Responsibility

Table 1 below describes the roles and responsibilities at all levels of IRWD as they relate to non-routine dam safety activities.

Table 1: Roles & Responsibilities for Non-routine Dam Safety Activities	
Role	Responsibility
Board	<ul style="list-style-type: none"> • Reviews and approves major dam safety and dam risk reduction measures. • Reviews and approves expenditures in accordance with IRWD’s procurement policy.
General Manager	<ul style="list-style-type: none"> • Oversees all of IRWD and assigns the primary responsibility for the Dam Safety Program to the Engineering Department.

**Dam Safety Program
Guideline No. 9
Non-routine Dam Safety Activities**

Executive Director of Technical Services	<ul style="list-style-type: none"> • Oversees Engineering Department, which is part of Technical Services Department. • Has frequent communication with the Dam Safety Engineer. • Evaluates and recommends to the IRWD Board major non-routine projects at dams (e.g., Issue Evaluation Studies, investigations, analyses, and/or dam modifications). • Identifies, in collaboration with Dam Safety Engineer, major and minor non-routine dam safety activities that require Board review.
Dam Safety Engineer	<ul style="list-style-type: none"> • Implements dam safety program including non-routine activities • Engages with IRWD decision makers as needed to provide support in decision making process, recommend interim risk reduction measures (IRRM), and implement permanent actions to reduce risk. • Engage the involvement of qualified consultants to provide expertise where required
Water Operations Staff	<ul style="list-style-type: none"> • Conducts field investigations and data gathering

5.0 References

- 5.1 GEI, “Dam and Reservoir Site Plan”, July 2020.
- 5.2 AECOM, “Syphon Reservoir Improvement Project Preliminary Design Report”, July 7, 2022.
- 5.3 AECOM, “Santiago Creek Dam Outlet Tower and Spillway Improvements Preliminary Design Report”, July 15, 2022.

1.0 Purpose

The purpose of this document is to provide guidance for Periodic Dam Safety Reviews (PDSR) of Irvine Ranch Water District's (IRWD) dams.

2.0 Definitions

Below is a summary of terms used herein that are related to this guideline.

Potential Failure Mode (PFM) - a plausible failure mechanism that could result in an uncontrolled release of the reservoir.

Risk - The product of the likelihood of the dam or appurtenant structure being loaded, adverse structural performance (e.g., dam failure) and the magnitude of the resulting consequences.

Risk Analysis - The use of available information to estimate the risk to individuals or populations from hazards. Risk analyses generally contain the following steps: development of potential failure mode including the multi-step event tree, hazard identification, and risk estimation.

Risk Assessment - The process of making a decision recommendation on whether existing risks are tolerable and present risk reduction measures are adequate, and if not, whether alternative risk reduction measures are justified or will be implemented. Risk assessment incorporates results from the risk analysis and risk evaluation phases.

Risk Evaluation - The process of examining and judging the significance of risk. The risk evaluation stage is where values enter the decision process including the associated consequences.

Semi Quantitative Risk Analysis (SQRA) - a risk categorization system that assigns likelihood of consequence categories to PFMs based on existing data.

Tolerable Risk - a risk within a range that society can live with so as to secure the benefits provided by the dam. It is a risk that is not to be regarded as negligible or ignored, but needs to be kept under review and reduce further if practicable.

3.0 Background

PDSR will improve IRWD's understanding of the risks that the district's dams pose to individuals or populations. Through the process of understanding the risks, IRWD will identify existing information that support individual risk estimates and gaps in information that contribute to the uncertainty in the risk estimates. IRWD's PDSR will generally include the following.

- Review of the dam, historic performance, changes to the dam and appurtenant structures
- Inspection of the dams and appurtenant structures

Dam Safety Program Guideline No. 10 Periodic Dam Safety Reviews

- Review of loading conditions
- Development, review, and screening of PFMs
- Consideration for the original designs and current design standards
- Consideration for methods of analysis and available best practices
- Improved understanding of confidence in risk and areas of uncertainty that could be evaluated to better define risk
- Identification of dam safety issues, if present
- Identification of action items focused on reducing risks and prioritization of the action items

To initiate the RIDM-based program, IRWD contracted with HDR in 2020 to complete SQRA on IRWD's five jurisdictional dams. The HDR and IRWD team completed risk analysis in 2021. Based on the 2021 completion, the next PDSR should occur in 2026 and every 5 years thereafter.

3.1 Division of Safety of Dams Periodic Dam Safety Reviews

The Department of Water Resources (DWR), Division of Safety of Dams (DSOD) ensure dam safety by being involved on several dam safety related activities. DSOD activities includes the following.

- Reviewing and approving modifications to dams.
- Performing independent analysis to understand dam and appurtenant structures performance. The analyses can include structural, hydrologic, hydraulic, and geotechnical evaluations.
- Overseeing construction to ensure work is being done in accordance with the approved plans and specifications.
- Inspecting each dam on an annual basis to ensure it is safe, performing as intended, and is not developing issues.
- Periodically reviewing the stability of dams and their major appurtenances with improved approaches and requirements and with consideration of earthquake hazards and hydrologic estimates.

The routine dam safety activity that DSOD performs is inspecting each dam on an annual basis. DSOD requires that dam owners under their jurisdiction complete annual dam surveillance reports for each dam. IRWD has a total of six dams, five of which are within DSOD's jurisdiction and are classified as Extremely High Hazard. The annual dam surveillance report includes a summary of monitoring data, a comparison to historic data, and an opinion from a Dam Engineering Consultant on the dam performance based on current and historic monitoring data, and field observations. Prior to completing the annual report, IRWD's Dam Engineering Consultant performing the dam surveillance inspects the site and documents their findings. Part of DSOD's annual inspection is confirming the outlet valves from the reservoir are exercised and operational.

In May 2020, DSOD notified dam owners in the state of California that they are transitioning to a risk informed DSP for purposes of prioritizing re-evaluation of existing dams. DSOD is not

currently considering incorporating RIDM into their minimum design requirements for dam improvements.

3.2 IRWD’s Periodic Dam Safety Reviews

As part of IRWD’s transition to a RIDM-based DSP, IRWD is conducting additional inspections and dam safety reviews. Pursuant to this, in 2021 IRWD completed SQRA on its portfolio of five jurisdictional dams. SQRA and the subsequent identification of action items set the course for improving the understanding of IRWD’s dam performance while also establishing a baseline for future PDSR. The PDSR includes developing PFM, Risk Analysis, Risk Assessment and

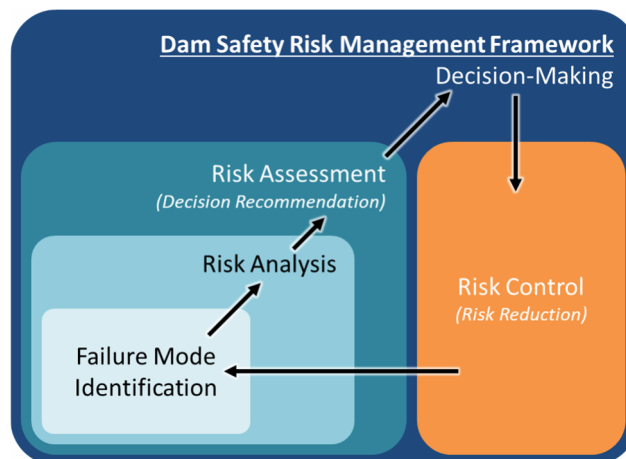

Figure 1: RIDM process.

Evaluation, and identifying opportunities to control the risk. Results from the PDSR are used to identify if dam safety concerns exist, identify action items, prioritize the action items, communicate risk to stakeholders and decision makers, and decision making.

4.0 General Guidelines for Periodic Dam Safety Reviews

Approximately every 5 years or as conditions at the dam or downstream of the dam substantial change, IRWD will conduct a PDSR. The four major components of the PDSR are described in the following subsections. In general, the risk analysis is a blend of the procedures established by the Army Corps of Engineers (ACOE), Federal Energy Regulatory Commission (FERC), Bureau of Reclamation, and Federal Emergency Management Agency (FEMA).

4.1 Data Summary Reports

In July 2021, HDR prepared comprehensive data summary reports for IRWD’s dams. The reports identify key historical information and summarize the documents in a brief synopsis to allow reviews to gain a quick overview of the dam history. The PDSR includes updating the Data Summary Reports with new information since the last update, and should document completed studies that were identified as areas of uncertainty in prior PDSRs. Updating the Data Summary Reports and understanding the prior reports is one of the initial steps in estimating risk.

4.2 Potential Failure Modes

There are three main categories for PFM loadings including normal operating conditions, hydraulic, and seismic. A minimum of three subject matter experts will

contribute to developing a wide range of PFM's and will approach the process of identifying the PFM's absent of preconceived notions of plausibility. Once the comprehensive list of PFM's are developed and categorized into the main loading categories, the subject matter experts, in partnership with IRWD, will shortlist the main PFM's that appear to be most plausible given the known features of the dam. The shortlisted PFM's will then be carried forward for risk analysis while also re-analyzing PFM's from the previous risk analysis cycle if new information on previously analyzed PFM's is available. After the PFM's are reviewed for plausibility and screened, a list of credible potential failure modes will be identified by the subject matter experts to carry forward for risk analysis.

4.3 Risk Analysis

Prior to performing risk analysis, the subject matter experts or agents thereof should inspect the dam being reviewed and perform a comprehensive review of available information that could influence the risk estimates. The analysis includes the process of developing the full event tree sequence for potential failure modes, identifying the structural performance, and estimating adverse consequences. Information on the type and frequency of loading (e.g., reservoir levels, floods, earthquakes., etc.) will be gathered and factored into the risk analysis.

The following Figure 2 is an example of an event tree for a PFM.

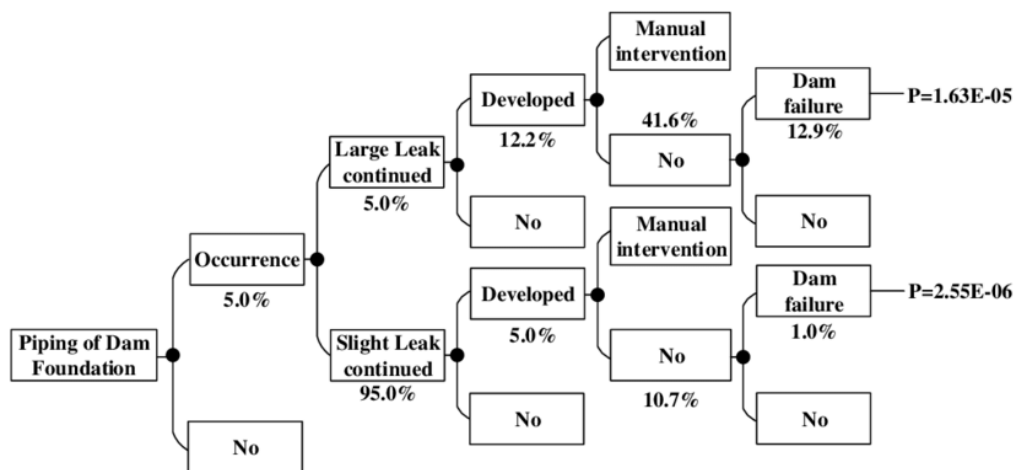

Figure 2: Sample event tree for a PFM from Army Corps of Engineers.

The following principles from FEMA P-1025 apply to risk analysis:

1. The basis for coherent risk analysis should be a thorough examination and description of potential failure modes analysis.
2. It should be recognized that each dam is unique in terms of purpose, geologic and demographic setting, design, structure, operations, and consequences.

3. A well-constructed dam safety analysis should include a discussion that supports and supplements the numerical risk estimates.

4.3.1 Consequence Analysis

IRWD developed and maintains inundation maps for each of its dams. In accordance with California Government Code Section 8589.5 dam owners are required to update the inundation maps a minimum of every 10 years or if there were significant changes to the dam that would alter the inundation maps or if there are significant changes to the conditions downstream of the dam. Consequence analysis, which is a component of estimating risk, uses the inundation maps to understand the areas downstream that could be impacted in the event of a sudden dam failure. While there are other considerations to consequence analysis, such as environmental impacts and economic impacts, IRWD uses potential life loss as a key indicator given that IRWD's dams are located in highly populated areas of Orange County. IRWD completed consequence analysis in 2021 and anticipates updating the analysis as the inundation maps are updated. The inundation maps used for the 2021 consequence analysis considers the future replacement of Syphon Dam with a new larger dam and replacing the Santiago Creek Dam spillway with a new higher spillway crest.

A variety of methods can be used to develop a Consequence Analysis for a dam. IRWD's baseline consequence analysis developed in 2020 utilized Reclamation Consequences Estimating Method (RCEM), which is a simplified method compared to other available methods such as Hec-LifeSim. Consequences are a major component to risk analysis and therefore refinement of the analysis with each PDSR should be consider as it could shift the location on the risk matrix.

4.4 Risk Assessment and Evaluation

IRWD generally follows the risk assessment guidelines established by the Bureau of Reclamation, Army Corps of Engineers (ACOE), and Federal Energy Regulatory Commission (FERC). The objective of risk assessment is for the Dam Engineering Consultant to identify a potential course of action for managing or accepting the risks associated with IRWD's dams and for IRWD to determine the course of action. The risk assessment is the process of considering estimated risk of the existing dam or project and plotting the results on the risk matrix to identify priorities and aide in the decision making process.

4.4.1 Risk Estimations

A minimum of three risk estimators that are experienced with developing risk estimates for dams, will be utilized to estimate the risk for the PFM's that are carried forward from the initial comprehensive review and screening process. Risk estimates will be based on known information about the dam, available information on loading frequencies,

Dam Safety Program Guideline No. 10 Periodic Dam Safety Reviews

experience in the industry, and with a keen interest in identifying information gaps that support risk estimates. The risk estimates should use the latest methodologies for estimating risk and where possible appropriately match the level of detail necessary to produce meaningful and actionable results. Once the subject matter experts prepare and agree on the risk estimates, the quantitative values should be plotted on the risk matrix. Figure 3 below shows an example of a simplified risk matrix, which plots the likelihood of dam failure versus the consequence if a dam failure occurs and includes the industry recognized level of tolerable risk and national average of failure likelihood.

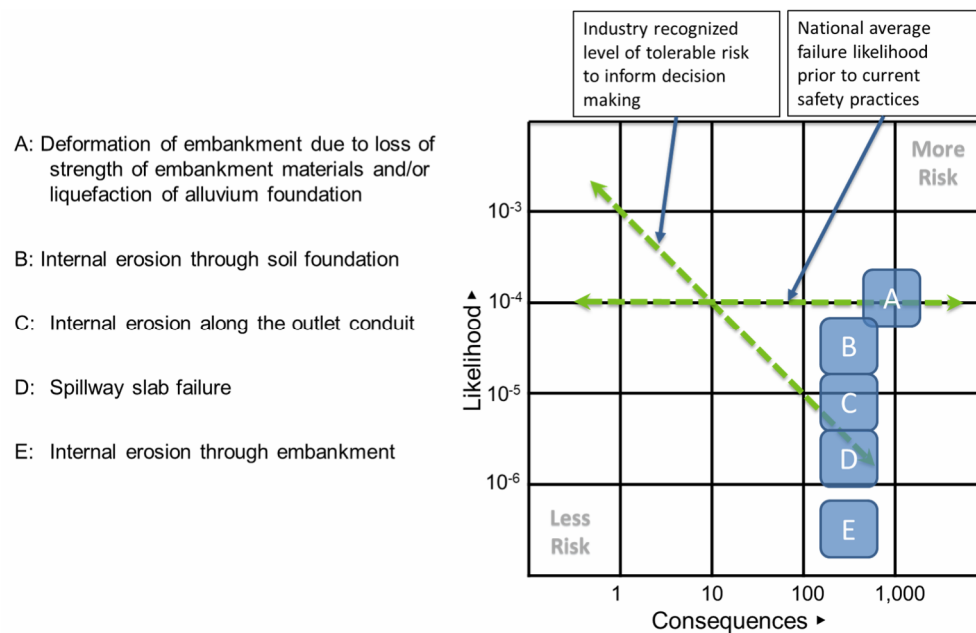

Figure 3: Sample Risk Matrix with risk estimates for various PFMs.

4.5 Risk Management and Decision Making Process

After completing risk analysis and assessment on the creditable PFMs, the Dam Engineering Consultant will summarize the results in a comprehensive PDSR report. IRWD Engineering and Operations staff will review the report and provide input on the recommended prioritization of action items. The PDSR report will serve as the basis for planning future projects and presenting recommendations to the Board.

5.0 Responsibility

Completing the PDSR requires the involvement of various staff at IRWD. Below in Table 1 is a summary of various tasks and responsible parties involved with completing and managing the PDSRs.

**Dam Safety Program
Guideline No. 10
Periodic Dam Safety Reviews**

Table 1: Summary of Periodic Dam Safety Review Responsibilities	
Description of Responsibility	Responsible Party
Retain services and manage Dam Engineering Consultant that prepares PDSR	Dam Safety Engineer
Participate in on-site inspection	Dam Safety Engineer, Water Operations staff
Participate in risk analysis workshops	Dam Safety Engineer, Water Operations staff
Review PDSR	Dam Safety Engineer, Water Operations Manager, Executive Director of Technical Services, Executive Director of Operations, General Manager
Report outcome of PDSR to Executive Director of Technical Services, Executive Director of Operations, General Manager, and Board	Dam Safety Engineer
Establish projects in Capital or Operating budget to complete identified action items	Dam Safety Engineer
Oversee the completion of action items identified in PDSR	Dam Safety Engineer

6.0 References

- 6.1 US Army Corps of Engineers, “Engineering and Design Safety of Dams – Policy and Procedures”, March 31, 2014
- 6.2 HDR, “Dam Safety Program Implementation Plan”, September 15, 2021
- 6.3 HDR, “Dam Safety Program Framework”, September 15, 2021
- 6.4 Bureau of Reclamation, “Interim Dam Safety Public Protection Guidelines”, August 2011
- 6.5 FERC, “Risk-Informed Decision Making for Dam Safety”, Version 1.1, June 2018
- 6.6 FERC, “Risk-Informed Decision Making Guidelines”, Version 4.1, March 2016
- 6.7 FEMA, “Federal Guidelines for Dam Safety Risk Management”, FEMA P-1025, January 2015
- 6.8 <https://water.ca.gov/damsafety/>
- 6.9 Data Summary Report Rattlesnake Canyon Dam, July 16, 2021
- 6.10 Data Summary Report Sand Canyon Dam, July 16, 2021
- 6.11 Data Summary Report San Joaquin Dam, July 16, 2021
- 6.12 Data Summary Report Syphon Dam, July 16, 2021
- 6.13 Data Summary Report Santiago Creek Dam, July 16, 2021

1.0 Purpose

The purpose of this document is to provide guidance for data management related to Irvine Ranch Water District's (IRWD) dams.

2.0 Definitions

Below is a summary of terms used herein that are related to IRWD's Dam Safety Program (DSP).

Dam Safety Portal – The Survey 123 ArcGIS Online based custom platform that IRWD uses to complete Inspection Reports, review Inspection Reports, summarize the historized data.

DIRT - [Dam Inventory and Records Tool](#) that is a Microsoft Power BI based application that IRWD uses to quickly and efficiently organize documents related to dam safety that are already located in Webdocs (IRWD's electronic library).

Webdocs - IRWD's electronic library system that stores documents that staff identifies as requiring retention.

3.0 Background

A variety of data are collected and managed as part of IRWD's DSP. The data includes, but is not limited to reports, evaluations, studies, investigations, plans, specifications, correspondences, instrumentation and operational data, and inspection reports. The data is collected and retained by various departments. The following subsections describe the main data categories, the items included in those categories, and the primary responsible party for managing the data.

3.1 Dam Inventory and Records Tool

The Dams and Storage Group developed the Dam Inventory and Records Tool (DIRT), which is a Microsoft Power BI based data management tool that is used to centralize significant dam related data. In 2022, the Dams and Storage Group completed the following tasks as part of developing the DIRT tool.

- Reviewed IRWD's records in Webdocs and reconciled with the records Division of Safety of Dams (DSOD) has in their repository.
- Identified missing information from Webdocs, such as but not limited to, DSOD inspection reports, plans, reports, and correspondences and uploaded them to Webdocs.
- Created meaningful and useful categories for the nearly 1,000 documents in Webdocs for ease of future searching and retrieving.
- Developed procedures and training material for maintaining the DIRT.

The Dams & Storage Group maintains the DIRT tool and updates the data, which is based on documents available in Webdocs. Generally, the group strives to complete updates a minimum of every 6-months. To successfully manage the DIRT, staff from the Dams & Storage Group

maintain an appropriate level of involvement on activities at dams, including when the activity is managed by an engineering group outside the Dams & Storage Group. The appropriate level of involvement allows the team to identify documents that should be flagged as part of the Dam Safety Program and become part of DIRT. Figure 1 describes the interaction between Project Managers and the Dam Safety Engineer to successfully manage data associated with the DIRT tool.

3.2 DSOD Inspection Reports

DSOD annually visits each of IRWD's jurisdictional dams and conducts an inspection. IRWD Operations and Dams & Storage Group staff accompany DSOD staff during their site visit. Following DSOD's annual inspection, they transmit an inspection report to the Dam Safety Engineer for further handling. DSOD inspection reports are flagged as part of the Dam Safety Program and become searchable in DIRT. They are also posted on IRWD's webpage for public viewing.

3.3 Instrumentation & Operational Data

Water Operations manages the collection and initial review of instrumentation and operational data. The data that Water Operations collects and records includes the following.

- Reservoir water level
- Reservoir storage
- Daily, monthly, and annual rainfall totals
- Operational adjustments (e.g., install flashboards, spillway usage, etc)
- Instrument readings (e.g., piezometers, flowmeters, survey monuments etc)
- Sedimentation accumulation
- Spillway flowrates (when used)

The instrumentation & operational data is separate from DIRT and saved in Operations directory (O:\SYSOPS\DISTRIBUTION FILE\Recycled). The instrumentation data is distributed monthly to the Dam Safety Engineer and Dam Engineering Consultant for further review and processing.

3.4 Survey Data

At a minimum, IRWD conducts annual surveys of survey monuments at IRWD's earthen embankment dams. The survey data is saved in S:\Dams & Storage\DSP\Annual Surveillance Reports and distributed to the Dam Engineering Consultant for incorporation into the Annual Surveillance Report. The survey data, by itself, is not searchable in DIRT, but once it is incorporated into the Annual Surveillance Report it is then searchable in DIRT.

3.5 Inspection Reports

The Inspection Reports completed in accordance with DSP Guideline No. 5 are generated by staff with the use of mobile devices. Working draft versions of the Inspection Report and

completed reports are saved in the Survey 123 ArcGIS Online environment. The completed Inspection Reports includes photos that are geospatially located and typically attributed to specific inspection criteria listed in the Inspection Reports. The reports are reviewed in the Survey 123 environment and may be exported if needed. At times, data is extracted from the Dam Safety Portal and communicated to the Dam Safety Program Committee or other participants of the DSP. The numerical results of the Inspection Reports are summarized in the Dam Safety Inspection Health Dashboard, which staff may review in the Dam Safety Portal.

3.6 Automatic Data Acquisition System

To be developed after implementing the cloud-based Automatic Data Acquisition System (ADAS).

4.0 Responsibility

Various staff are responsible for dam safety data management. Table 1 summarizes staff's data management responsibilities.

Table 1: Data Management Responsibilities		
Description of Responsibility	Responsible Party	Notes
Collect and record reservoir water level	Water Operations	<ul style="list-style-type: none"> Reservoir level is collected daily and saved in O:\SYSOPS\DISTRIBUTION FILE\Recycled
Collect and record instrumentation and operational data (e.g., piezometers, seepage flow rates, etc)	Water Operations	<ul style="list-style-type: none"> Instrumentation data is routed monthly to the Dam Safety Engineer and Dam Engineering Consultant.
Manages DIRT system and data in DIRT	Dams & Storage Group	<ul style="list-style-type: none"> The Dams & Storage Group manages a document that explains step-by-step how to retrieve data from Webdocs and update DIRT.
Receives DSOD's inspection reports, coordinates responses to action items, and ensures DSOD's concerns are addressed	Dam Safety Engineer	<ul style="list-style-type: none"> Responding to DSOD's inspection reports are usually a collaboration with multiple IRWD departments.
Collect and maintain survey data	Dams & Storage Group	<ul style="list-style-type: none"> Data is reviewed by Dam Safety Engineer and Dam Engineering Consultant.
Coordinates the uploading of the Annual Surveillance Report to IRWD's website	Dam Safety Engineer, Communications	<ul style="list-style-type: none"> This is completed for each jurisdictional dam and contains many of the data discussed in this guideline.
Record and report discharge flow data during critical valve exercising to Regulatory Compliance	Water Operations	<ul style="list-style-type: none"> Regulatory Compliance includes the reported flow data in their annual report to the Regional Water Quality Control Board.

5.0 Exhibits

Figure 1: Data Management Process for IRWD's Dam Inventory and Records Tool

6.0 References

- 6.1 GEI, "Dam and Reservoir Site Plan", July 2020
- 6.2 AECOM, "Syphon Reservoir Improvement Project Preliminary Design Report", July 7, 2022.
- 6.3 AECOM, "Santiago Creek Dam Outlet Tower and Spillway Improvements Preliminary Design Report", July 15, 2022

Figure 1: Data Management Process for IRWD's Dam Inventory and Records Tool

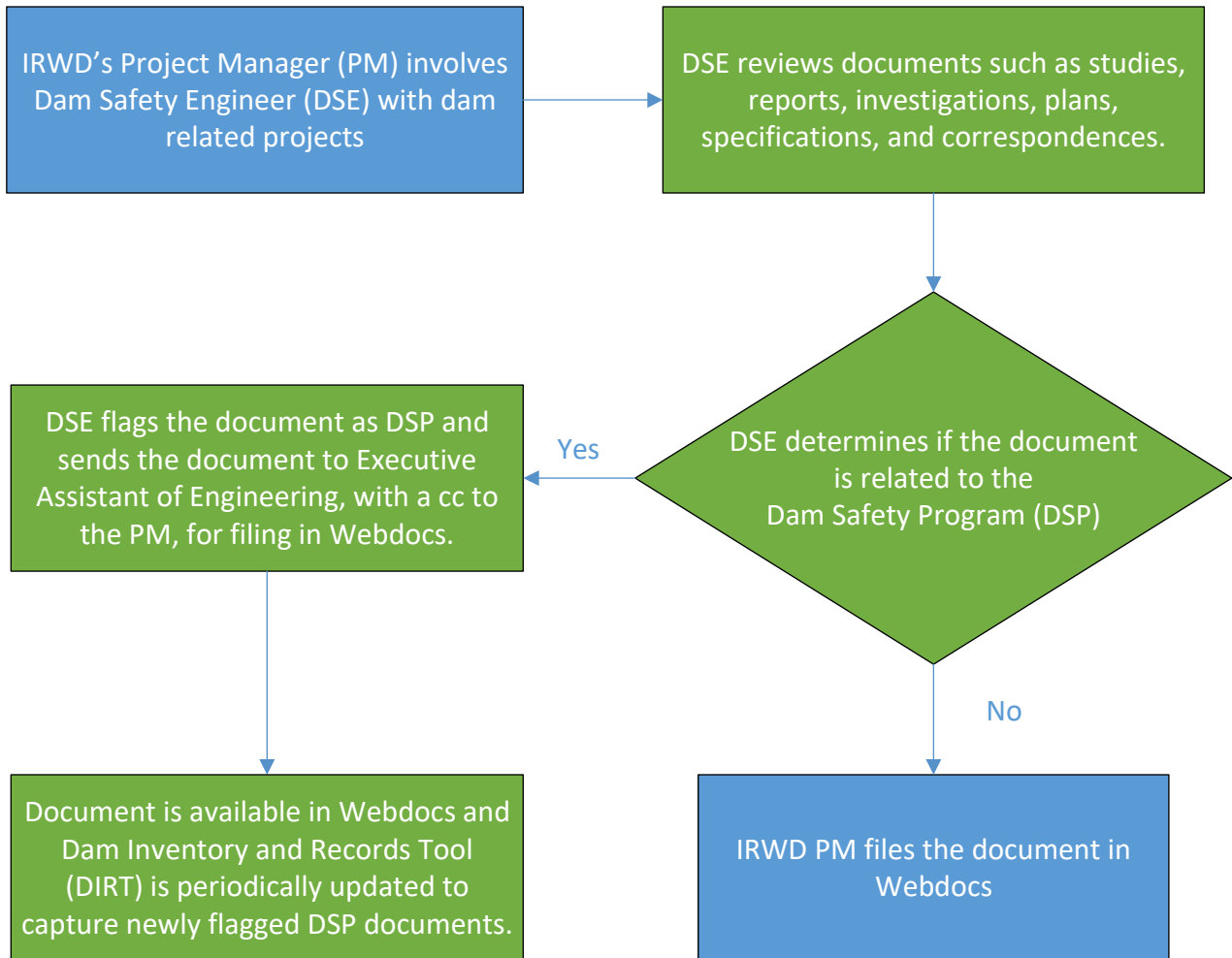

Blue = Project Manager Item

Green = Dam Safety Engineer Item

Emergency Action Plans & Response Plans



Santiago Creek Dam, No. 75
Santiago Reservoir
Valve Replacement Plan



Irvine Ranch Water District (IRWD) and Serrano Water District (SWD) are actively working on the design of the Outlet Tower and Spillway Replacement project. While the Districts work towards completing the improvements, they have implemented an Interim Operation Plan that targets maximum water elevations to reduce the potential use of the spillway until major improvements to the tower and spillway are complete. The Interim Operation Plan relies on releasing Irvine Lake water to Santiago Creek to reduce the water elevation when it exceeds a targeted maximum level. This release to Santiago Creek assumes the from the lake to the creek are fully functional.

The purpose of this Valve Replacement Plan is to identify a prompt response to valve repairs or replacements to ensure the Districts maximize hydraulic capacities in the event the lake level requires lowering.

SWD is the lead agency for maintaining the valves on the outlet tower and at the outlet works. Figure 1 depicts the location of the various valves and the attached Santiago Creek Dam – Outlet Tower Extension drawing shows the various gate valves and sizes on the outlet tower.

Valve Exercising Program:

- SWD will exercise all of the valves on the outlet tower and at the outlet works structure twice per year: once prior to the winter season (October 31) and once at the start of the summer season (April 2). If any of the valves have limited performance that negatively impact the hydraulic capacity, SWD, with support from IRWD, will cause the immediate repair or replacement of the valve.

Underwater Service Provider:

- SWD routinely uses Dive Core (Dan Gross, Vice President, 562-439-8287, Divecorr@aol.com, <http://divecorr.com/>), to provide underwater valve repair services. In the event valve repairs or replacements are required, SWD will contract with Dive Core, or the like, to promptly repair the valve.
- A second contact for underwater inspection and mechanical repairs is Workhorse Diving and Salvage, Jason Jettie, Owner, 602-705-5739.



Figure 1: Santiago Reservoir valve locations for releasing water to Santiago Creek.

Operational Considerations

Santiago Creek Dam, No. 75
Santiago Reservoir Interim Lake Level Operations Plan

In December 2019, the Irvine Ranch Water District (IRWD) and Serrano Water District (SWD) completed a comprehensive condition assessment of the Santiago Creek Dam spillway. The spillway assessment, conducted by GEI Consultants (GEI), is complete and concludes that the spillway structure is reaching the end of its useful life. The purpose of this interim lake level operations plan is to prescribe seasonal lake levels that will reduce the probability of discharging a significant amount of flow over the spillway until the existing spillway is replaced. The operating parameters for the lake are summarized below.

Summer Season (April 2 – October 30):

- Lake will be operated without restriction. Maximum water surface elevation will remain at El. 790 or El. 794 with the flashboards installed.

Winter Season (October 31 – April 1):

- On October 31, the water level in the lake will be below El. 762.5.
- At any time during the winter season, if the water level in the lake reaches El. 762.5, IRWD and SWD will implement measures to reduce the water level to below El. 762.5. Measures may include delivering water to IRWD's Baker Water Treatment Plant or SWD's Howler Plant and/or discharging water through the cone valve to Santiago Creek.
- Starting March 14 of each year, IRWD and SWD will evaluate the water level in the lake and the weather forecast to determine if the water level can be increased above El. 762.5. If the water level in the lake and the weather forecast permit, the water level in the lake may be increased to a maximum elevation of El. 772.5. Raising the water level in the lake will only be contemplated at the end of the winter season between March 14 and April 1.

Inspection Program:

On annual basis, at the end of each winter season (April 1), the Districts will conduct a surficial inspection of the spillway, similar to the inspections conducted under the Phase I Spillway Assessment dated July 1, 2018. In addition to the annual inspections, the Districts will conduct a surficial inspection of the spillway after each spill event that passes more than 0.5-feet of water over the crest of the spillway. Documentation for each inspection will be prepared, along with any recommendations for temporary spillway repairs.

Santiago Creek Dam, No. 75
Santiago Reservoir Interim Lake Level Operations Plan

Monitoring Program:

During spill events that generate 0.5-feet or more of water depth over the crest of the spillway, the Districts will monitor the spillway performance and document the following.

- Water depth over the crest of the spillway
- Spillway flow rate using the spillway capacity curve
- Condition of erosion prevention measures along the base of Santiago Creek Dam and under the spillway flip bucket.
- Condition of spillway chute
- Documentation of abnormal flow regimes or observed structural deficiencies.
- Recommendations for temporary spillway repairs, if identified.

February 15, 2022

Prepared by: J. Moeder / R. Mori

Submitted by: K. Burton

Approved by: Paul A. Cook



ENGINEERING AND OPERATIONS COMMITTEE

RATTLESNAKE DAM SEISMIC EVALUATION UPDATE

SUMMARY:

IRWD recently completed initial semi-qualitative risk analyses on all five of its dams. One of the findings identified the need for additional seismic evaluation of Rattlesnake Dam. In October 2021, IRWD retained HDR to perform a preliminary seismic evaluation of Rattlesnake Dam. HDR recently completed the evaluation, and staff will provide a presentation summarizing the overall scope of the evaluation and associated findings, recommendations, and next steps.

BACKGROUND:

Rattlesnake Dam was constructed in 1959 by the Irvine Company, and IRWD acquired it in 1971. Rattlesnake Dam is an earthen embankment dam with a spillway crest elevation of 412 feet, which yields a storage volume of 1,400 acre-feet (AF). The dam, which is built on alluvium fill, was initially operated up to the spillway crest elevation until the early 1980s when IRWD and the Division of Safety of Dams (DSOD) began evaluating the liquefaction potential of the alluvium foundation. Those evaluations resulted in a DSOD-established maximum water level restriction of elevation 406-feet. IRWD has operated Rattlesnake up to this level since 1982, which yields a reduced total reservoir storage volume of 1,100 AF.

As part of enhancing IRWD's dam safety program and integrating Risk Informed Decision Making into the program, HDR completed semi-qualitative risk analysis on all five of IRWD's dams. One of the findings identified the need for additional seismic evaluation at Rattlesnake Dam. In October 2021, IRWD contracted with HDR to perform a preliminary seismic evaluation, which confirmed the need for additional geotechnical investigations and for additional in-depth seismic analyses. Staff will provide a presentation summarizing the overall scope of the evaluation and associated findings, recommendations, and next steps. A glossary of terms and the draft presentation are included as Exhibits "A" and "B", respectively.

FISCAL IMPACTS:

Staff will bring a consultant selection recommendation for additional seismic analyses and geotechnical investigations to the Board for consideration in the coming months at which time staff will also recommend the addition of a new project to the capital budget to fund that work.

ENVIRONMENTAL COMPLIANCE:

This project is not subject to the California Environmental Quality Act (CEQA) as authorized under the California Code of Regulations, Title 14, Chapter 3, Section 15061 (b) (3), in that CEQA applies only to projects that may result in a direct physical change in the environment or reasonably foreseeable indirect physical change in the environment.

RECOMMENDATION:

Receive and file.

LIST OF EXHIBITS:

Exhibit “A” – Glossary of Terms

Exhibit “B” – Rattlesnake Dam Preliminary Seismic Evaluation Draft Presentation

EXHIBIT “A”

GLOSSARY OF TERMS

Definition:

Risk: the product of likelihood of a structure being loaded, adverse structural performance, and the magnitude of the resulting consequences.

Abbreviations:

AF	Acre-Feet
DSOD	Division of Safety of Dams
DSP	Dam Safety Program
FT	Feet
IRRM	Interim Risk Reduction Measure
PFM	Potential Failure Mode
RIDM	Risk-Informed Decision Making
SQRA	Semi-Quantitative Risk Analysis

Note: This page is intentionally left blank.



Rattlesnake Dam Preliminary Seismic Evaluation

Engineering and Operations Committee
February 15, 2022



1

Agenda

- History of Rattlesnake Dam & Background
- Preliminary Seismic Evaluation and Findings
- Project Schedule & Next Steps



Rattlesnake Dam

Irvine Ranch Water District 2

2



History of Rattlesnake Dam

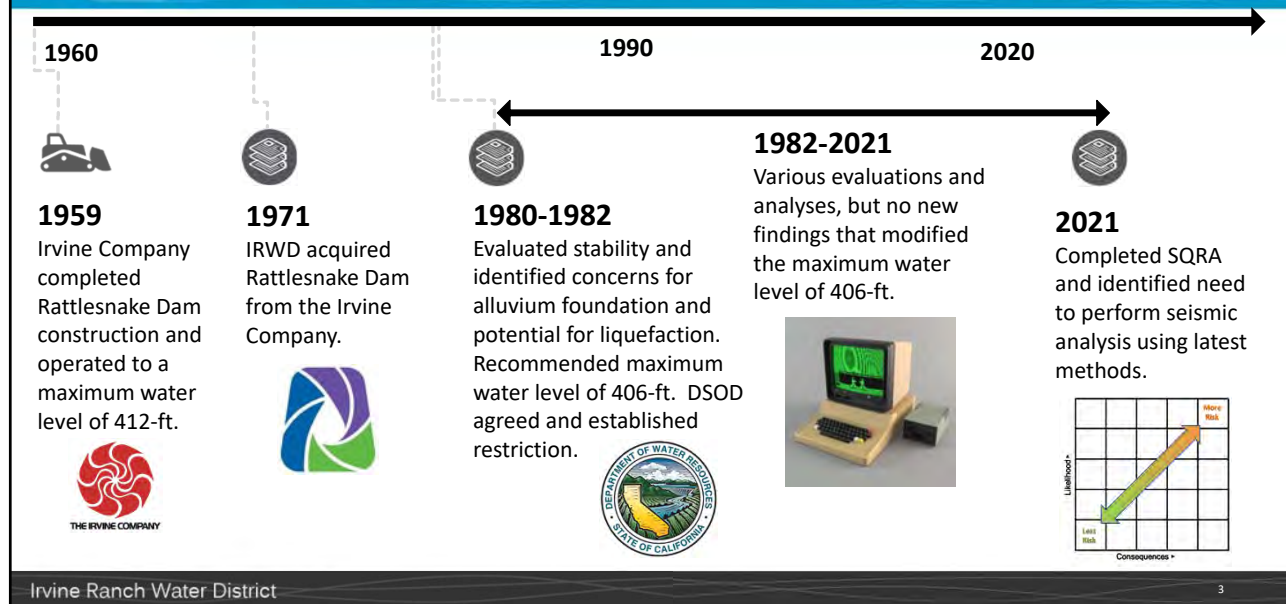

3

Background – Recap of October 2021 Board Meeting

- Established the framework for enhancing IRWD’s dam safety program that includes Risk-Informed Decision Making (RIDM) as a core component of the program
- Completed Semi-Quantitative Risk Analysis (SQRA) on IRWD’s dam portfolio that identified the following:
 - No conditions requiring emergency actions were identified
 - Rattlesnake Dam posed a higher risk in the portfolio driven by seismic performance, potential for liquefaction of alluvium foundation, and seepage through the embankment
 - Initial action items to complete in 2022 including evaluating Interim Risk Reduction Measure at Rattlesnake Dam

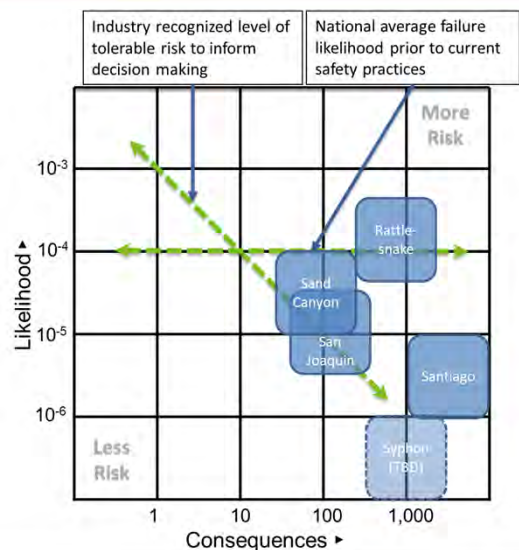

Irvine Ranch Water District

4



Background – Potential Failure Modes Influencing Total Risk at Rattlesnake Dam

- A: Deformation of embankment due to loss of strength of embankment materials and/or liquefaction of alluvium foundation
- B: Internal erosion through soil foundation
- C: Internal erosion along the outlet conduit
- D: Spillway slab failure
- E: Internal erosion through embankment

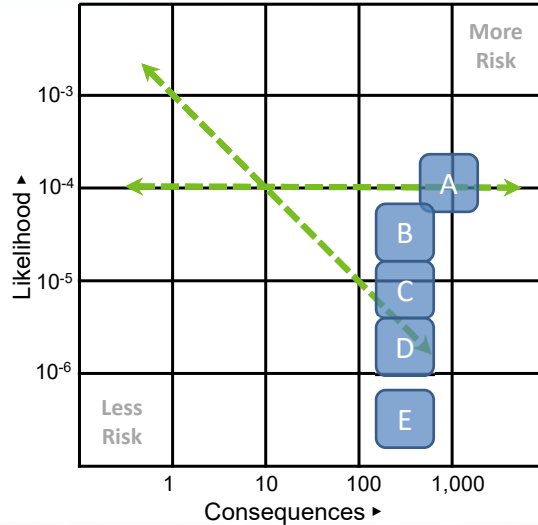

5

Preliminary Seismic Evaluation and Findings

- Previous studies indicate presence of alluvium foundation material, potential for liquefaction of foundation, and a wide range of material strengths.
- Additional geotechnical investigations and evaluations are needed to characterize extent and strengths of liquefiable materials.
- Permitted operating level of 406-ft may not provide adequate risk reduction.
- Preliminary slope stability analysis indicates significant risk reduction by operating at or below elevation 395-ft.

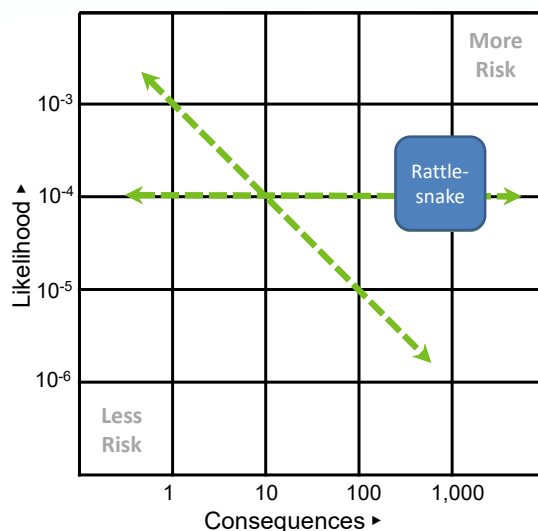

6



Findings – Interim Maximum Water Level at Rattlesnake Reservoir

Finding:

Decreasing the maximum water level reduces the risk of the PFM with the greatest likelihood of occurring.

Action:

Staff intends to continue operating the reservoir at a maximum water level of ~~395-ft~~ until further notice.

Revised to 388-ft on 9/27/24

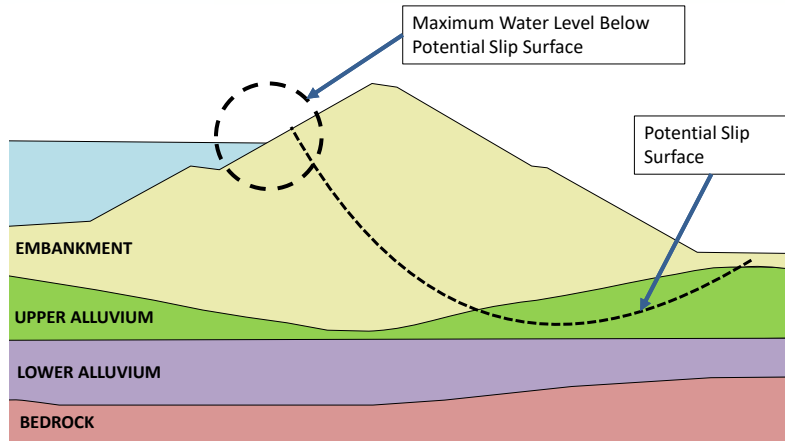

7

Rattlesnake Reservoir Storage

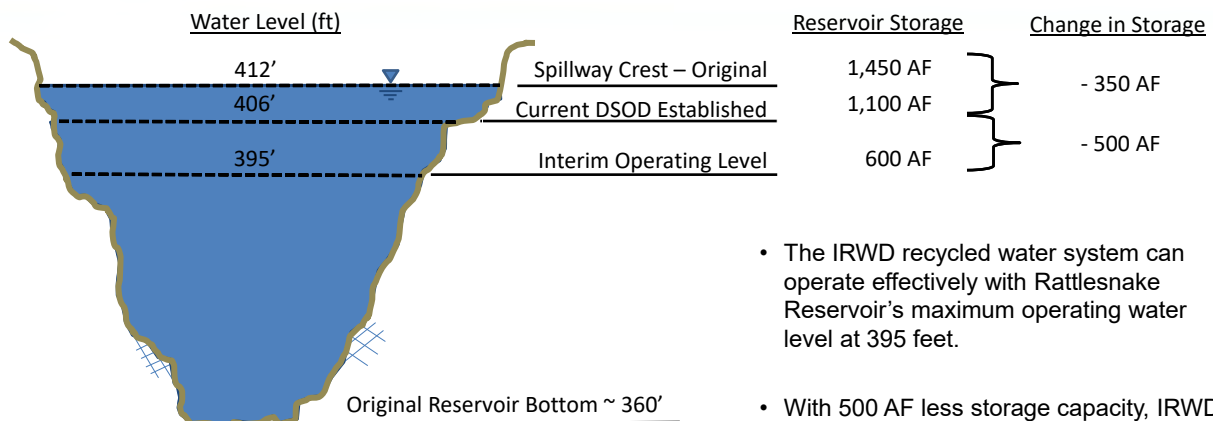

- The IRWD recycled water system can operate effectively with Rattlesnake Reservoir's maximum operating water level at 395 feet.
- With 500 AF less storage capacity, IRWD will need to buy an additional 500 AF of supplemental water. (For 2022, an estimated cost of \$400,000.)

8



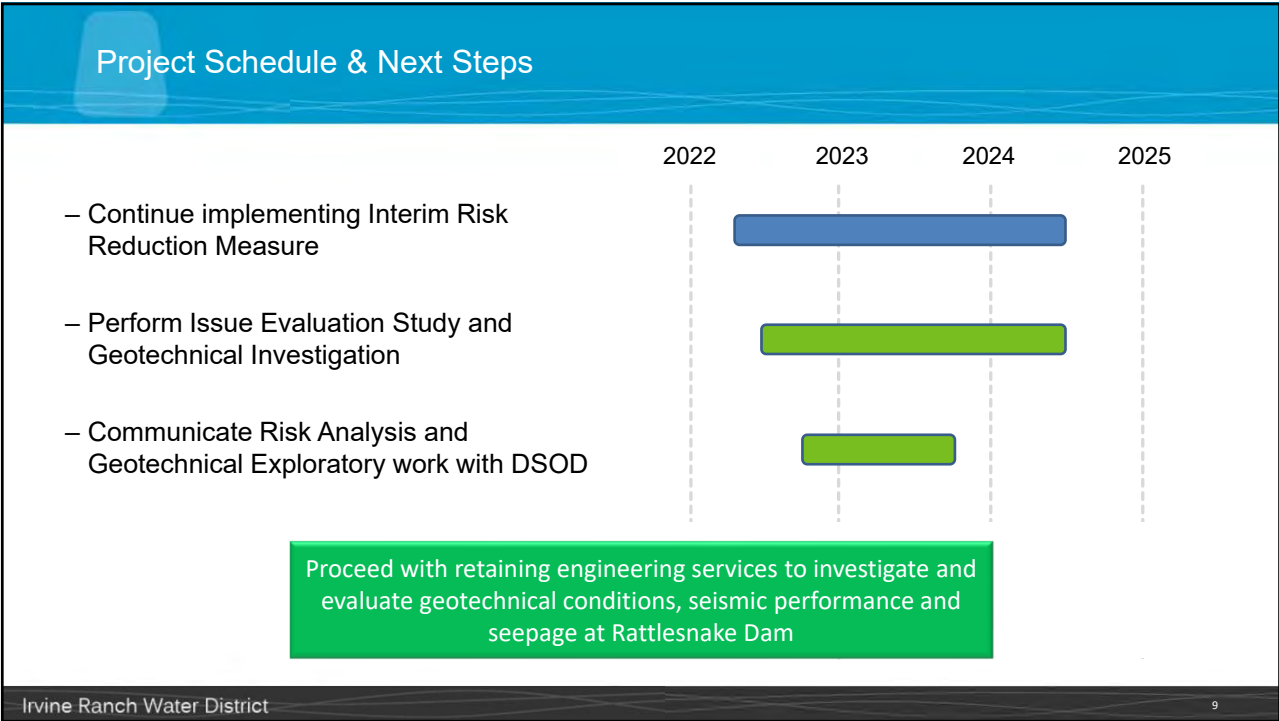

9

Questions/Discussion

10

10





Santiago Creek Dam, No. 75
Santiago Reservoir
Valve Replacement Plan



Spare Parts and Equipment:

Below is a table summary of the valves and the contingency plan associated with each valve.

Item	Description	Location	Backup/Contingency	Notes
1	24" Gate Valve	Outlet Tower – Elev. 749.7'	SWD will ensure that there is a minimum of one set of repair parts on site. This assumes valves are repaired in-place rather than a complete replacement of the valve.	
2	24" Gate Valve	Outlet Tower – Elev. 739'		
3	24" Gate Valve	Outlet Tower – Elev. 722'		
4	24" Gate Valve	Outlet Tower – Elev. 719'		
5	30" Gate Valve	Outlet Tower – Elev. 710'	n/a	<i>Under silt line</i>
6	30" Gate Valve	Outlet Tower – Elev. 698.4'	n/a	<i>Under silt line</i>
7	30" Gate Valve	Outlet Tower – Elev. 688'	n/a	<i>Under silt line</i>
8	30" Gate Valve	Outlet Tower – Elev. 679.5'	n/a	<i>Under silt line</i>
9	30" Butterfly Valve	Outlet works structure	SWD will procure and store on site a replacement actuator.	<ul style="list-style-type: none"> • 4-6 week lead time for a new general stock valve. • 12-16 week lead time for a new special order valve.
10	30" Cone Valve	Outlet works structure	If the cone valve fails in the close position, the valve could be removed and the upstream butterfly valve could be used to control flow to the creek.	