

CONSTRUCTION MANUAL

STANDARD DRAWINGS AND
GENERAL TECHNICAL SPECIFICATIONS



**Irvine Ranch
Water District**

IRVINE RANCH WATER DISTRICT

**CONSTRUCTION
MANUAL**

**FOR THE CONSTRUCTION OF WATER,
SEWER, AND RECYCLED WATER FACILITIES**

Kevin L. Burton

Kevin L. Burton, Executive Director of Technical Services

FEBRUARY 2025

TABLE OF CONTENTS

Standard Drawings

NUMBER	DESCRIPTION	DATE
Water		
W-1	1" Copper Service	February 2025
W-2	2" Copper Service	February 2025
W-3	1" or 2" Service Connection for PVC, Steel, ACP and DIP	February 2025
W-4	1" or 2" Service Manifold	February 2025
W-5	3", 4", 6", 8" and 10" Meter Assembly	February 2025
W-6	Double Check Backflow Assembly, 3" and Larger	February 2025
W-7	Reduced Pressure Principle Backflow Assembly	February 2025
W-8	Fire Hydrant	February 2025
W-9	Recycled Water Wharf Head Hydrant	February 2025
W-10	Water Sample Station	February 2025
W-11	1" or 2" Air Release and Vacuum Relief	February 2025
W-12	Temporary Flush-out Assembly	February 2025
W-13	Flush-out Assembly	February 2025
W-14	Blow off / Bottom Drain Assembly	February 2025
W-15	Pressure Regulating Station (PRV)	February 2025
W-16	Thrust Block	February 2025
W-17	Water Trench	February 2025
W-18	<Not Used>	
W-19	Cut-in Tee for PVC, DIP and ACP Mains	February 2025
W-20	Mortar Lined and Coated Steel Pipe Joints	February 2025
W-21	Steel Casing for Water Pipe	February 2025
W-22	Valve Box	February 2025
W-23	Valve Stem Extension	February 2025
W-24	Pipe Support	February 2025
Sewer		
S-1	Manhole	February 2025
S-2	<Not Used>	
S-3	Sewer Lateral	February 2025
S-4	Cut-in Wye Connection	February 2025
S-5	Terminal Cleanout	February 2025
S-6	Sewer Trench	February 2025
S-7	Steel Casing for Sewer Pipe	February 2025
Cathodic Protection		
CP-1	Two Wire Test Station	February 2025
CP-2	<Not Used>	
CP-3	Casing Test Station	February 2025
CP-4	Insulator Test Station	February 2025
CP-5	Cathodic Protection Rectifier and Shunt Panel	February 2025
CP-6	Test Box, Wiring, and Identification Tags	February 2025
CP-7	Test Box Locations	February 2025
CP-8	Alumino-Thermic (CAD) Welding	February 2025
CP-9	Bonding for Pipe Joints and Fittings	February 2025
CP-10	Insulating Joints	February 2025
General		
G-1	Removable Guard Post	February 2025
G-2	Utility Marker	February 2025
G-3	Access Gate	February 2025
G-4	Retaining Wall	February 2025
G-5	Vault Ladder	February 2025
G-6	Vault Sumps	February 2025
G-7	Vault Vent	February 2025
G-8	Wall Penetration for 2-1/2" < Pipe < 4"	February 2025
G-9	Wall Penetration for Pipe ≥ 4"	February 2025
G-10	Concrete Slope Anchors	February 2025

TABLE OF CONTENTS

Water Standard Drawings

NUMBER	DESCRIPTION	DATE
W-1	1" Copper Service	Feb 2025
W-2	2" Copper Service	Feb 2025
W-3	1" or 2" Service Connection for PVC, Steel, ACP and DIP	Feb 2025
W-4	1" or 2" Service Manifold	Feb 2025
W-5	3", 4", 6", 8" and 10" Meter Assembly	Feb 2025
W-6	Double Check Backflow Assembly, 3" and Larger	Feb 2025
W-7	Reduced Pressure Principle Backflow Assembly	Feb 2025
W-8	Fire Hydrant	Feb 2025
W-9	Recycled Water Wharf Head Hydrant	Feb 2025
W-10	Water Sample Station	Feb 2025
W-11	1" or 2" Air Release and Vacuum Relief	Feb 2025
W-12	Temporary Flush-out Assembly	Feb 2025
W-13	Flush-out Assembly	Feb 2025
W-14	Blow off / Bottom Drain Assembly	Feb 2025
W-15	Pressure Regulating Station (PRV)	Feb 2025
W-16	Thrust Block	Feb 2025
W-17	Water Trench	Feb 2025
W-18	<Not Used>	
W-19	Cut-in Tee for PVC, DIP and ACP Mains	Feb 2025
W-20	Mortar Lined and Coated Steel Pipe Joints	Feb 2025
W-21	Steel Casing for Water Pipe	Feb 2025
W-22	Valve Box	Feb 2025
W-23	Valve Stem Extension	Feb 2025
W-24	Pipe Support	Feb 2025

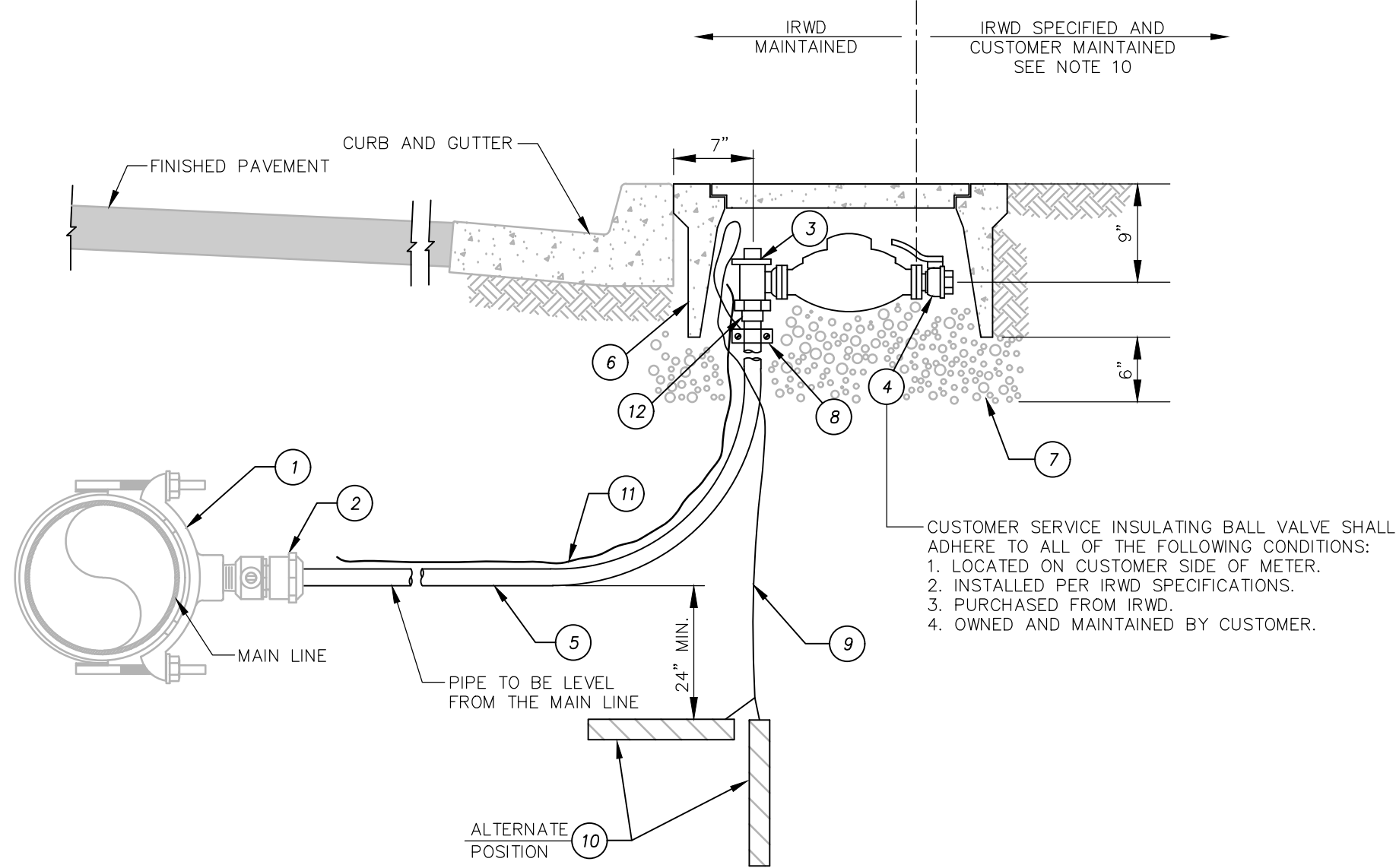

LOCATE LATERAL WITH 2" HIGH "W" FOR POTABLE WATER OR "RW" FOR RECYCLED WATER ON FACE OF CURB WHERE THE LATERAL CROSSES UNDER THE CURB. USE WHEEL GRINDER, 1/4" DEEP GROOVE.

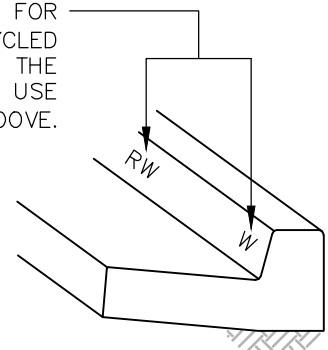

ZINC ANODE SIZES FOR 1" COPPER SERVICES

COPPER PIPE LENGTH (FEET)	ZINC ANODE SIZE (INCHES)	ZINC ANODE WEIGHT (LBS)
0 TO 45	1.4 X 1.4 X 30	15
45 TO 90	2.0 X 2.0 X 30	30

CUSTOMER SERVICE INSULATING BALL VALVE SHALL ADHERE TO ALL OF THE FOLLOWING CONDITIONS:
 1. LOCATED ON CUSTOMER SIDE OF METER.
 2. INSTALLED PER IRWD SPECIFICATIONS.
 3. PURCHASED FROM IRWD.
 4. OWNED AND MAINTAINED BY CUSTOMER.

ITEM MATERIALS

- 1 — 1" SERVICE CONNECTION TO MAIN LINE PER IRWD STD. DWG. W-3.
- 2 — 1" BALL CORPORATION STOP PER IRWD STD. DWG. W-3.
- 3 — 1" X METER SIZE ANGLE METER STOP WITH LOCKING WING AND F.I.P.T. INLET CONNECTION.
- 4 — 1" CUSTOMER SERVICE INSULATING BALL VALVE, METER NUT X F.I.P.T.
- 5 — 1" COPPER SERVICE PIPE TYPE "K" SOFT.
- 6 — METER BOX WITH READING LID. COMPOSITE POLYMER CONCRETE BOXES AND LIDS PER IRWD STD. SPEC. SECTION 03462. "IRWD" SHALL BE STAMPED ON INNER LID.
- 7 — 6" THICK BASE OF 3/4" CRUSHED ROCK.
- 8 — WIRE CLAMP, SEE NOTE 7.
- 9 — AWG NO. 8 STRANDED COPPER ANODE LEAD WIRE, LEAVE 18" OF COILED WIRE IN METER BOX.
- 10 — ZINC ANODE (SEE TABLE HEREON FOR SIZE OF ANODE) AND LEAD WIRE. ANODE TO BE PLACED VERTICALLY OR HORIZONTALLY AT A MIN. SEPARATION OF 24" FROM THE COPPER SERVICE.
- 11 — IDENTIFICATION TAPE PER IRWD STD. SPEC. SECTION 15151. TAPE TO COPPER PIPE AT 2' INTERVALS USING 2" WIDE 10-MIL TAPE AND PLACE ON TOP OF SAND LAYER.
- 12 — WROT COPPER ADAPTER, SWEAT X M.I.P.T.

NOTES:

1. SERVICE CONNECTION SHALL NOT BE MADE WITHIN 18" OF VALVE, COUPLING, JOINT, OR FITTING.
2. 1" COPPER SERVICE SHALL BE USED FOR 3/4" OR 1" METERS.
3. INSTALL CORPORATION STOP WITH KEY SIDEWAYS IN OPEN POSITION.
4. SET TOP OF METER BOX FLUSH WITH SIDEWALK OR CURB AS SHOWN.
5. THE WATER SERVICE SHALL EXTEND PERPENDICULAR TO THE CENTERLINE OF THE STREET FROM THE WATER MAIN TO THE METER STOP.
6. METER BOX SHALL BE SET BEHIND SIDEWALK WHERE SIDEWALK IS ADJACENT TO CURB, OR IN PARKWAY BETWEEN CURB AND SIDEWALK.
7. ANODE LEAD WIRE SHALL BE CLAMPED AND TESTED PER IRWD STD. SPEC. SECTION 16640, SEE TABLE HEREON FOR ZINC ANODE SIZES (SPLICES NOT ALLOWED).
8. METER BOX SHALL NOT BE LOCATED WITHIN ANY PATH OF TRAVEL, INCLUDING BUT NOT LIMITED TO, ACCESS ROADS, SIDEWALKS, TRAILS, OR DRIVEWAY APPROACHES.
9. METER BOX SHALL NOT BE LOCATED WITHIN ANY CONCRETE SURFACE.
10. GASKET BETWEEN CUSTOMER SERVICE INSULATING BALL VALVE AND IRWD-MAINTAINED METER SHALL BE OWNED AND MAINTAINED BY CUSTOMER.
11. PIPE BEDDING ZONE PER IRWD STD. SPEC. SECTION 02223. 4" MINIMUM SAND BEDDING, 12" MINIMUM SAND ABOVE PIPE, AND 24" MINIMUM TRENCH WIDTH.

1" COPPER SERVICE

IRVINE RANCH WATER DISTRICT, ENGINEERING DEPARTMENT
 APPROVED BY:

 KEVIN L. BURTON R.M.E. M28832
 EXECUTIVE DIRECTOR, TECHNICAL SERVICES

FEBRUARY 2025
 REVISION



**IRWD
 STD. DWG.
 W-1**
 NOT TO SCALE
 SHEET 1 OF 1

LOCATE LATERAL WITH 2" HIGH "W" FOR POTABLE WATER OR "RW" FOR RECYCLED WATER ON FACE OF CURB WHERE THE LATERAL CROSSES UNDER THE CURB. USE WHEEL GRINDER, 1/4" DEEP GROOVE.

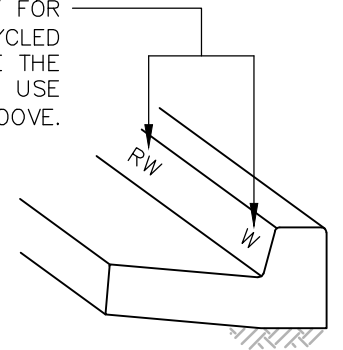

ZINC ANODE SIZES FOR 2" COPPER SERVICES

COPPER PIPE LENGTH (FEET)	ZINC ANODE SIZE (INCHES)	ZINC ANODE WEIGHT (LBS)
0 TO 22	1.4 X 1.4 X 30	15
22 TO 45	2.0 X 2.0 X 30	30
45 TO 70	2.0 X 2.0 X 48	40
70 TO 90	2.0 X 2.0 X 60	60

ITEM MATERIALS

- 1 — 2" SERVICE CONNECTION TO MAIN LINE PER IRWD STD. DWG. W-3.
- 2 — 2" BALL CORPORATION STOP PER IRWD STD. DWG. W-3.
- 3 — 2" X METER SIZE BRASS ANGLE METER STOP WITH LOCKING WING AND F.I.P.T. INLET CONNECTION.
- 4 — CUSTOMER SERVICE VALVE METER NUT X F.I.P.T. WITH INSULATING FLANGE.
- 5 — 2" COPPER SERVICE PIPE TYPE "K" RIGID.
- 6 — METER BOX WITH READING LID. COMPOSITE POLYMER CONCRETE BOXES AND LIDS PER IRWD STD. SPEC. SECTION 03462. "IRWD" SHALL BE STAMPED ON INNER LID.
- 7 — 6" THICK BASE OF 3/4" CRUSHED ROCK.
- 8 — WIRE CLAMP, SEE NOTE 7.
- 9 — AWG NO. 8 STRANDED COPPER ANODE LEAD WIRE, LEAVE 18" OF COILED WIRE IN METER BOX.
- 10 — ZINC ANODE (SEE TABLE HEREON FOR SIZE OF ANODE) AND LEAD WIRE. ANODE TO BE PLACED VERTICALLY OR HORIZONTALLY AT A MINIMUM SEPARATION OF 24" FROM THE COPPER SERVICE.
- 11 — 2" WROT COPPER 90° BEND, SWEAT X SWEAT.
- 12 — IDENTIFICATION TAPE PER IRWD STD. SPEC. SECTION 15151. TAPE TO COPPER PIPE AT 2' INTERVALS USING 2" WIDE 10-MIL TAPE AND PLACE ON TOP OF SAND LAYER.
- 13 — WROT COPPER ADAPTER, SWEAT X M.I.P.T.

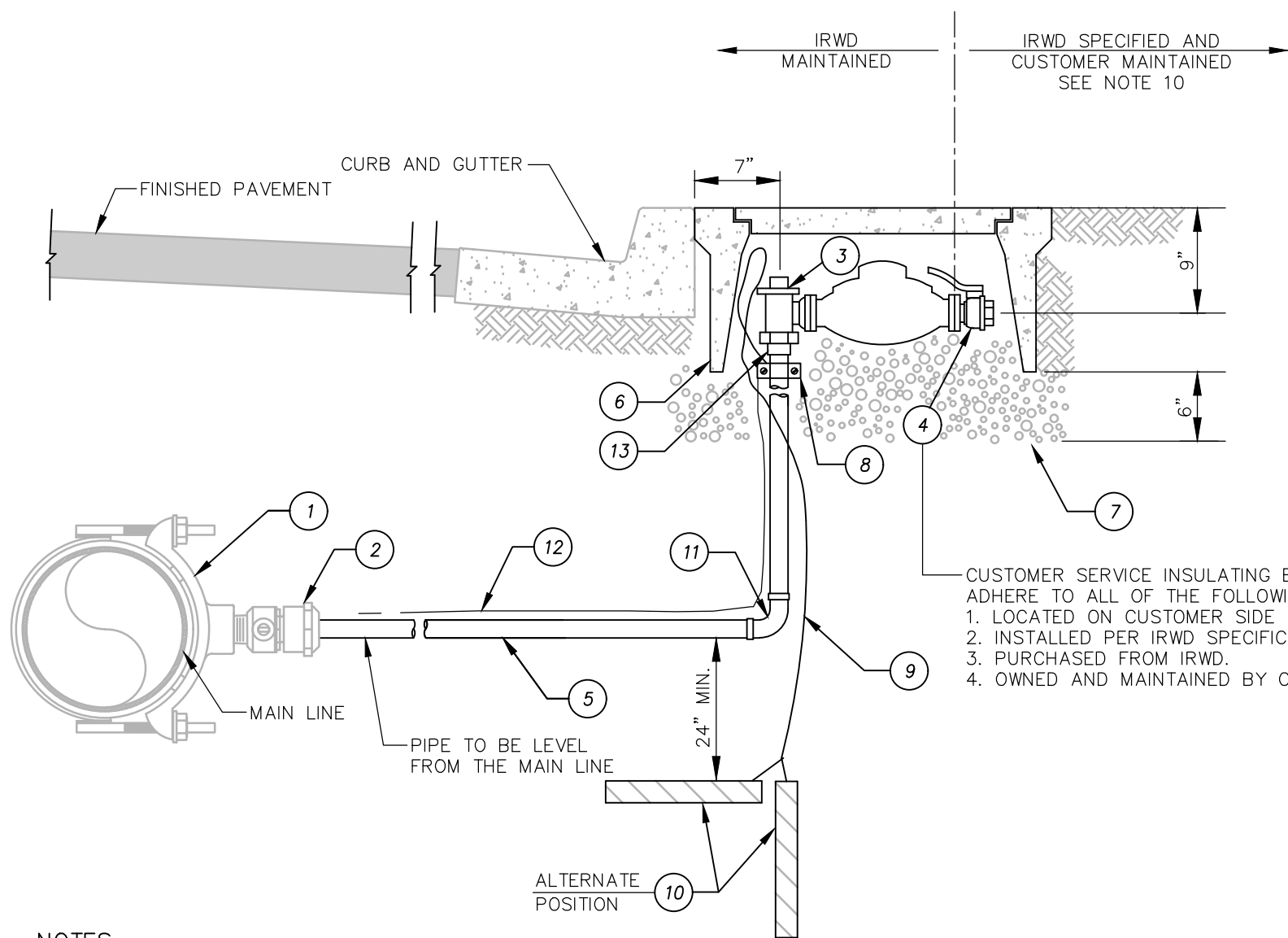

CUSTOMER SERVICE INSULATING BALL VALVE SHALL ADHERE TO ALL OF THE FOLLOWING CONDITIONS:
 1. LOCATED ON CUSTOMER SIDE OF METER.
 2. INSTALLED PER IRWD SPECIFICATIONS.
 3. PURCHASED FROM IRWD.
 4. OWNED AND MAINTAINED BY CUSTOMER.

NOTES:

1. SERVICE CONNECTION SHALL NOT BE MADE WITHIN 18" OF VALVE, COUPLING, JOINT OR FITTING.
2. 2" COPPER SERVICE SHALL BE USED FOR 1-1/2" OR 2" METERS.
3. INSTALL CORPORATION STOP WITH KEY SIDEWAYS IN OPEN POSITION.
4. SET TOP OF METER BOX FLUSH WITH SIDEWALK OR CURB AS SHOWN.
5. THE WATER SERVICE SHALL EXTEND PERPENDICULAR TO THE CENTERLINE OF THE STREET FROM THE WATER MAIN TO THE METER STOP.
6. METER BOX SHALL BE SET BEHIND SIDEWALK WHERE SIDEWALK IS ADJACENT TO CURB, OR IN PARKWAY BETWEEN CURB AND SIDEWALK.
7. ANODE LEAD WIRE SHALL BE CLAMPED AND TESTED PER IRWD STD. SPEC. SECTION 16640, SEE TABLE HEREON FOR ZINC ANODE SIZES (SPICES NOT ALLOWED).
8. METER BOX SHALL NOT BE LOCATED WITHIN ANY PATH OF TRAVEL, INCLUDING BUT NOT LIMITED TO, ACCESS ROADS, SIDEWALKS, TRAILS, OR DRIVEWAY APPROACHES.
9. METER BOX SHALL NOT BE LOCATED WITHIN ANY CONCRETE SURFACE.
10. GASKET BETWEEN CUSTOMER SERVICE INSULATING BALL VALVE AND IRWD-MAINTAINED METER SHALL BE OWNED AND MAINTAINED BY CUSTOMER.
11. PIPE BEDDING ZONE PER IRWD STD. SPEC. SECTION 02223. 4" MINIMUM SAND BEDDING, 12" MINIMUM SAND ABOVE PIPE, AND 24" MINIMUM TRENCH WIDTH.

2" COPPER SERVICE

IRVINE RANCH WATER DISTRICT, ENGINEERING DEPARTMENT
 APPROVED BY:

 KEVIN L. BURTON R.M.E. M28832
 EXECUTIVE DIRECTOR, TECHNICAL SERVICES

FEBRUARY 2025
 REVISION



IRWD
 STD. DWG.
 W-2
 NOT TO SCALE
 SHEET 1 OF 2

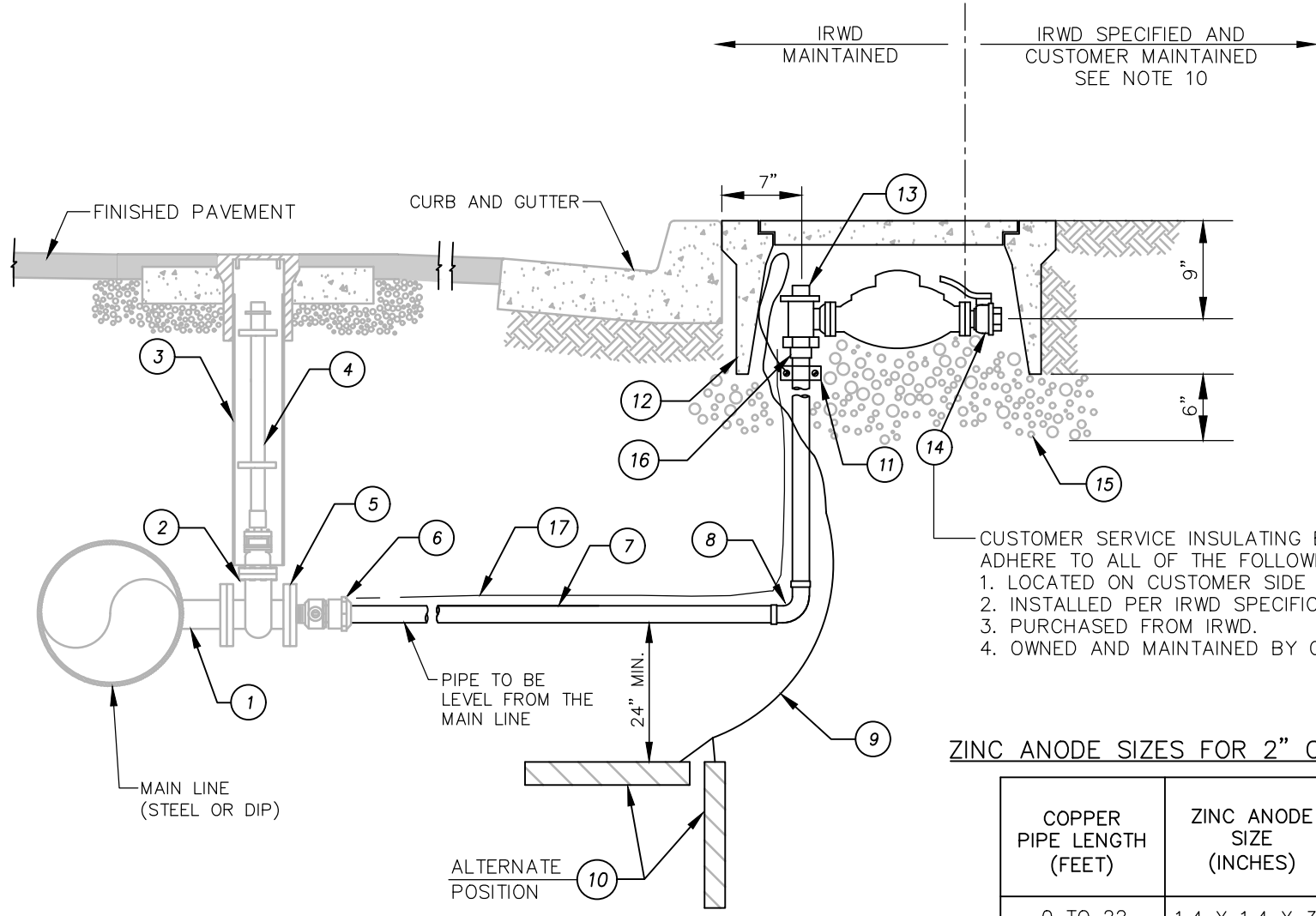

LOCATE LATERAL WITH 2" HIGH "W" FOR POTABLE WATER OR "RW" FOR RECYCLED WATER ON FACE OF CURB WHERE THE LATERAL CROSSES UNDER THE CURB. USE WHEEL GRINDER, 1/4" DEEP GROOVE.

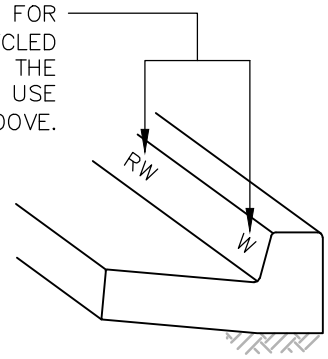

ITEM MATERIALS

- 1 — FLANGED OUTLET (MIN. SIZE = 4").
- 2 — RW GATE VALVE OR BUTTERFLY VALVE, F.E. X F.E.
- 3 — VALVE AND VALVE BOX INSTALLATION PER IRWD STD. DWG. W-22.
- 4 — VALVE STEM EXTENSION PER IRWD STD. DWG. W-23 (WHERE REQUIRED).
- 5 — FLANGED OUTLET SIZE X 2" TAPPED D.I. COMPANION FLANGE.
- 6 — 2" BRASS INSULATING BALL CORPORATION STOP PER IRWD STD. DWG. W-3.
- 7 — 2" COPPER SERVICE PIPE TYPE "K" RIGID.
- 8 — 2" WROT COPPER 90° ELBOW, SLIP X SLIP.
- 9 — AWG NO. 8 STRANDED COPPER ANODE LEAD WIRE, LEAVE 18" OF COILED WIRE IN METER BOX.
- 10 — ZINC ANODE (SEE TABLE HEREON FOR SIZE OF ANODE) AND LEAD WIRE. ANODE TO BE PLACED VERTICALLY OR HORIZONTALLY AT A MIN. SEPARATION OF 24" FROM THE COPPER SERVICE.
- 11 — GROUND WIRE CLAMP, SEE NOTE 7.
- 12 — METER BOX WITH READING LID. COMPOSITE POLYMER CONCRETE BOXES AND LIDS PER IRWD STD. SPEC. SECTION 03462. "IRWD" TO BE STAMPED ON INNER LID.
- 13 — 2" X METER SIZE BRASS ANGLE METER STOP WITH LOCKING WING AND F.I.P. INLET CONNECTION.
- 14 — 2" BRASS CUSTOMER SERVICE VALVE METER, FLANGE X F.I.P.T., WITH INSULATING FLANGE.
- 15 — 6" THICK BASE OF 3/4" CRUSHED ROCK.
- 16 — WROT COPPER ADAPTER, SWEAT X M.I.P.T.
- 17 — IDENTIFICATION TAPE PER IRWD STD. SPEC. SECTION 15151. TAPE TO COPPER PIPE AT 2' INTERVALS USING 2" WIDE 10-MIL TAPE AND PLACE ON TOP OF SAND LAYER.

ZINC ANODE SIZES FOR 2" COPPER SERVICES

COPPER PIPE LENGTH (FEET)	ZINC ANODE SIZE (INCHES)	ZINC ANODE WEIGHT (LBS)
0 TO 22	1.4 X 1.4 X 30	15
22 TO 45	2.0 X 2.0 X 30	30
45 TO 70	2.0 X 2.0 X 48	40
70 TO 90	2.0 X 2.0 X 60	60

NOTES:

1. SERVICE CONNECTION SHALL NOT BE MADE WITHIN 18" OF VALVE, COUPLING, JOINT OR FITTING.
2. 2" COPPER SERVICE SHALL BE USED FOR 1-1/2" OR 2" METERS.
3. INSTALL CORPORATION STOP WITH KEY SIDEWAYS IN OPEN POSITION.
4. SET TOP OF METER BOX FLUSH WITH SIDEWALK OR CURB AS SHOWN.
5. THE WATER SERVICE SHALL EXTEND PERPENDICULAR TO THE CENTERLINE OF THE STREET FROM THE WATER MAIN TO THE METER STOP.
6. METER BOX SHALL BE SET BEHIND SIDEWALK WHERE SIDEWALK IS ADJACENT TO CURB, OR IN PARKWAY BETWEEN CURB AND SIDEWALK.
7. ANODE LEAD WIRE SHALL BE CLAMPED AND TESTED PER IRWD STD. SPEC. SECTION 16640, SEE TABLE HEREON FOR ZINC ANODE SIZES (SPLICES NOT ALLOWED).
8. METER BOX SHALL NOT BE LOCATED WITHIN ANY PATH OF TRAVEL, INCLUDING BUT NOT LIMITED TO, ACCESS ROADS, SIDEWALKS, TRAILS, OR DRIVEWAY APPROACHES.
9. METER BOX SHALL NOT BE LOCATED WITHIN ANY CONCRETE SURFACE.
10. GASKET BETWEEN CUSTOMER SERVICE INSULATING BALL VALVE AND IRWD-MAINTAINED METER SHALL BE OWNED AND MAINTAINED BY CUSTOMER.
11. PIPE BEDDING ZONE PER IRWD STD. SPEC. SECTION 02223. 4" MINIMUM SAND BEDDING, 12" MINIMUM SAND ABOVE PIPE, AND 24" MINIMUM TRENCH WIDTH.

2" COPPER SERVICE ON STEEL OR DIP GREATER THAN 16'

IRVINE RANCH WATER DISTRICT, ENGINEERING DEPARTMENT

APPROVED BY: *Kevin L. Burton*

KEVIN L. BURTON R.M.E. M28832
EXECUTIVE DIRECTOR, TECHNICAL SERVICES

FEBRUARY 2025
REVISION

IRWD STD. DWG. W-2

NOT TO SCALE
SHEET 2 OF 2

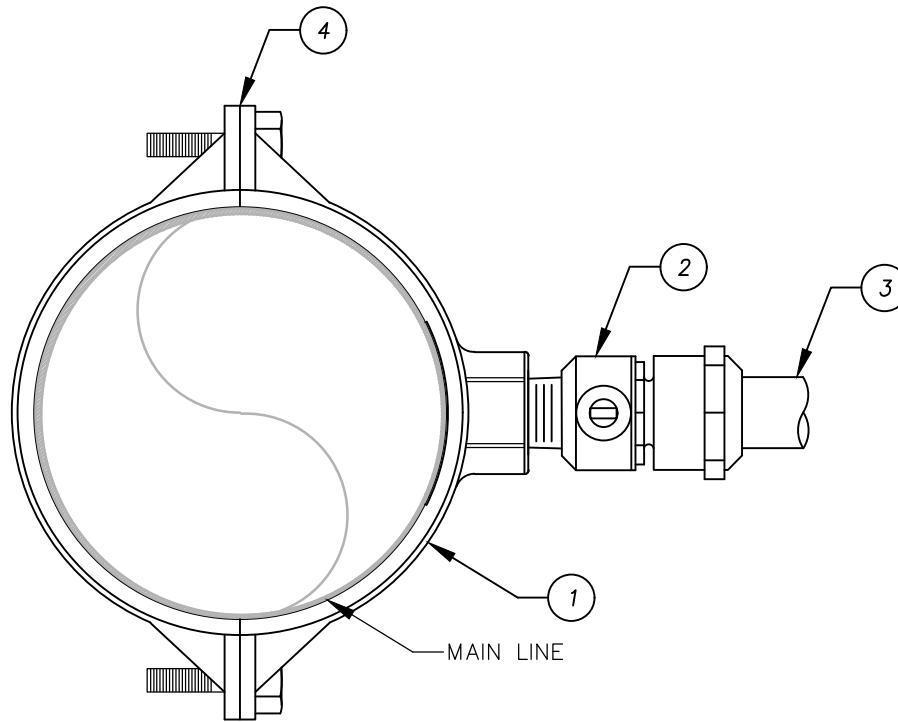

ITEM MATERIALS

- ① — 2-PIECE SERVICE SADDLE PER STD. SPEC. SECTION 15057 FOR O.D. CONTROLLED PVC PIPE WITH 1" OR 2" F.I.P.T. OUTLET.
- ② — 1" OR 2" BRASS BALL CORPORATION STOP, M.I.P.T. X COMPRESSION.
- ③ — 1" OR 2" COPPER SERVICE PIPE, TYPE "K".
- ④ — 1" OR 2" SERVICE CONNECTIONS:
 2 BOLTS ON EACH SIDE FOR 8" DIA. PIPE AND SMALLER.
 1 BOLT ON EACH SIDE FOR 10" AND 12" DIA. PIPE.

NOTES:

- 1. SADDLE CONNECTIONS MAY BE USED ON PVC PIPE SIZES UP TO AND INCLUDING 12". FOR SIZES GREATER THAN 12", SERVICE CONNECTIONS AND OTHER APPARATUS SHALL BE CONNECTED VIA D.I. OR CML&C STEEL TEE FITTINGS WITH FLANGED OUTLET.
- 2. PLACE OPERATING NUT POSITION AS SHOWN ABOVE.

1" OR 2" SERVICE CONNECTION FOR PVC

IRVINE RANCH WATER DISTRICT, ENGINEERING DEPARTMENT

APPROVED BY:

KEVIN L. BURTON R.M.E. M28832
 EXECUTIVE DIRECTOR, TECHNICAL SERVICES

FEBRUARY 2025
 REVISION



Irvine Ranch
 WATER DISTRICT

**IRWD
 STD. DWG.
 W-3**

NOT TO SCALE
 SHEET 1 OF 5

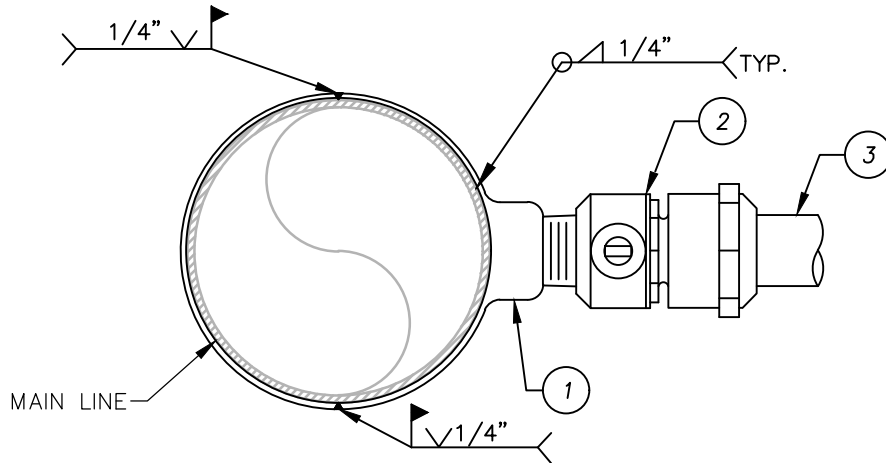

STEEL PIPE 6" DIA. AND SMALLER

ITEM

MATERIALS

- ① — 1/4" THICK 2-PIECE 6" WIDE ROLLED STEEL WEDDING BAND REINFORCING STRAP WITH EXTRA HEAVY WELDED STEEL OUTLET (THREAD-O-LET) COUPLING, WITH 1" OR 2" F.I.P.T.
- ② — 1" OR 2" INSULATING BRASS BALL CORPORATION STOP, M.I.P.T. X COMPRESSION.
- ③ — 1" OR 2" COPPER SERVICE PIPE, TYPE "K".

NOTES:

1. FOR USE ON EXISTING 6" DIA. AND SMALLER STEEL PIPE ONLY AND ARE SUBJECT TO APPROVAL BY DISTRICT.
2. PLACE OPERATING NUT POSITION AS SHOWN ABOVE.

1" OR 2" SERVICE CONNECTION FOR STEEL PIPE

IRVINE RANCH WATER DISTRICT, ENGINEERING DEPARTMENT

APPROVED BY:

Kevin L. Burton
 KEVIN L. BURTON R.M.E. M28832
 EXECUTIVE DIRECTOR, TECHNICAL SERVICES

FEBRUARY 2025
 REVISION



Irvine Ranch
 WATER DISTRICT

IRWD
 STD. DWG.
 W-3

NOT TO SCALE
 SHEET 2 OF 5

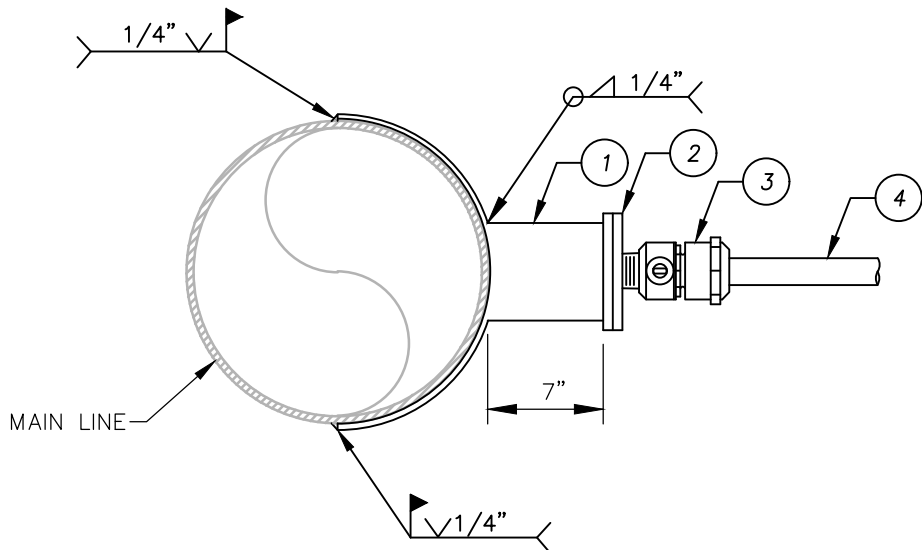

STEEL PIPE 8" DIA. AND LARGER

ITEM

MATERIALS

- ① — 1/4" — THICK CML&C STEEL 6" FLANGED NOZZLE WITH 1/4" — THICK STEEL HALF WRAPPER PLATE.
- ② — 6" X 1" OR 2" D.I. COMPANION FLANGE.
- ③ — 1" OR 2" INSULATING BALL CORPORATION STOP, M.I.P.T. X COMPRESSION.
- ④ — 1" OR 2" COPPER SERVICE PIPE, TYPE "K".

NOTES:

- 1. FOR USE ON EXISTING 8" DIA. AND LARGER STEEL PIPE.
- 2. PLACE OPERATING NUT POSITION AS SHOWN ABOVE.

1" OR 2" SERVICE CONNECTION FOR STEEL PIPE

IRVINE RANCH WATER DISTRICT, ENGINEERING DEPARTMENT

APPROVED BY:

Kevin L. Burton
 KEVIN L. BURTON R.M.E. M28832
 EXECUTIVE DIRECTOR, TECHNICAL SERVICES

FEBRUARY 2025
 REVISION



Irvine Ranch
 WATER DISTRICT

IRWD
 STD. DWG.
 W-3

NOT TO SCALE
 SHEET 3 OF 5

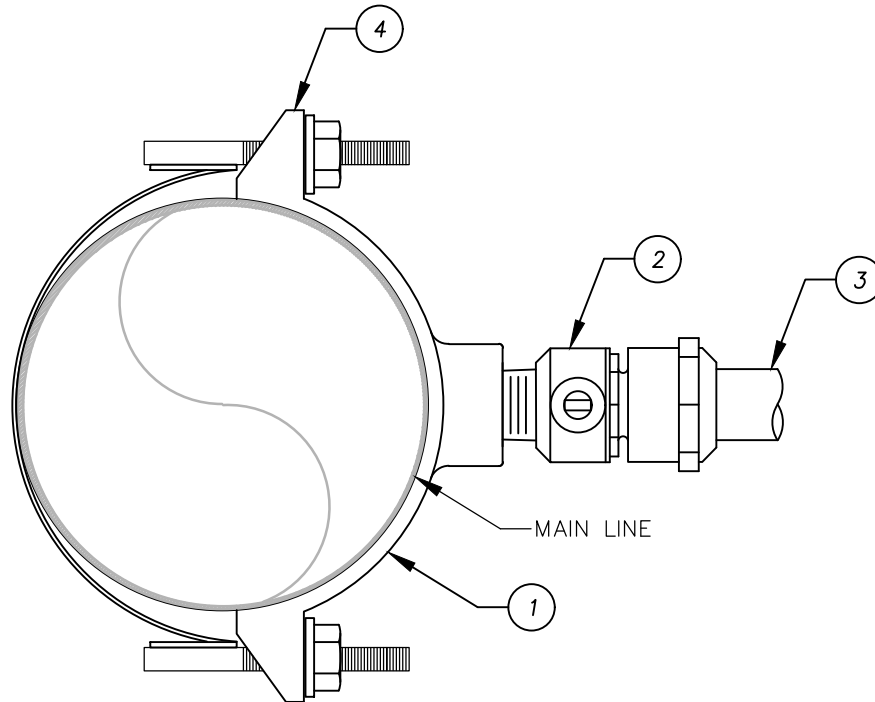

ITEM

MATERIALS

- ① — BRASS SERVICE SADDLE WITH DOUBLE STAINLESS STEEL STRAPS AND 1" OR 2" F.I.P.T. OUTLET.
- ② — 1" OR 2" BALL CORPORATION STOP, M.I.P.T. X COMPRESSION (TYP.).
- ③ — 1" OR 2" COPPER SERVICE PIPE, TYPE "K".
- ④ — 1" OR 2" SERVICE CONNECTIONS:
2 EACH SIDE — TYPE 316 STAINLESS STEEL SADDLE BOLTS AND NUTS.

NOTES:

1. SADDLE CONNECTIONS MAY BE USED ON ACP SIZES UP TO AND INCLUDING 12". FOR SIZES GREATER THAN 12", SERVICE CONNECTIONS AND OTHER APPARATUS SHALL BE CONNECTED VIA D.I. TEE FITTINGS WITH FLANGED OUTLET.
2. PLACE OPERATING NUT POSITION AS SHOWN ABOVE.

1" OR 2" SERVICE CONNECTION FOR ACP

IRVINE RANCH WATER DISTRICT, ENGINEERING DEPARTMENT

APPROVED BY:

KEVIN L. BURTON R.M.E. M28832
EXECUTIVE DIRECTOR, TECHNICAL SERVICES

FEBRUARY 2025
REVISION



Irvine Ranch
WATER DISTRICT

**IRWD
STD. DWG.
W-3**

NOT TO SCALE
SHEET 4 OF 5

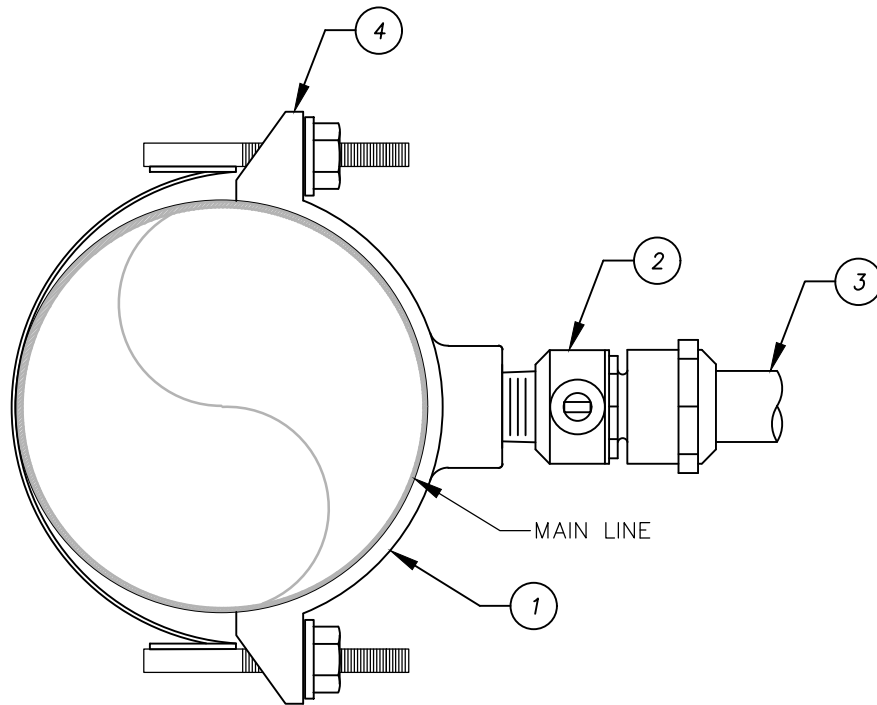

- | <u>ITEM</u> | <u>MATERIALS</u> |
|-------------|---|
| ① | NYLON COATED MALLEABLE IRON BODY SERVICE SADDLE WITH DOUBLE TYPE 316 STAINLESS STEEL STRAPS AND 1" OR 2" F.I.P.T. OUTLET. |
| ② | 1" OR 2" INSULATING BRASS BALL CORPORATION STOP, M.I.P.T. X COMPRESSION. |
| ③ | 1" OR 2" COPPER SERVICE PIPE, TYPE "K". |
| ④ | 1" OR 2" SERVICE CONNECTIONS:
2 EACH SIDE – TYPE 316 STAINLESS STEEL SADDLE BOLTS AND NUTS. |

NOTES:

1. SADDLE CONNECTIONS MAY BE USED ON DIP SIZES UP TO AND INCLUDING 12". FOR SIZES GREATER THAN 12", SERVICE CONNECTIONS AND OTHER APPARATUS SHALL BE CONNECTED VIA D.I. TEE FITTINGS WITH A FLANGED OUTLET.
2. PLACE OPERATING NUT POSITION AS SHOWN ABOVE.

1" OR 2" SERVICE CONNECTION FOR DIP

IRVINE RANCH WATER DISTRICT, ENGINEERING DEPARTMENT

APPROVED BY:

Kevin L. Burton
 KEVIN L. BURTON R.M.E. M28832
 EXECUTIVE DIRECTOR, TECHNICAL SERVICES

FEBRUARY 2025
 REVISION



Irvine Ranch
 WATER DISTRICT

**IRWD
 STD. DWG.
 W-3**

NOT TO SCALE
 SHEET 5 OF 5

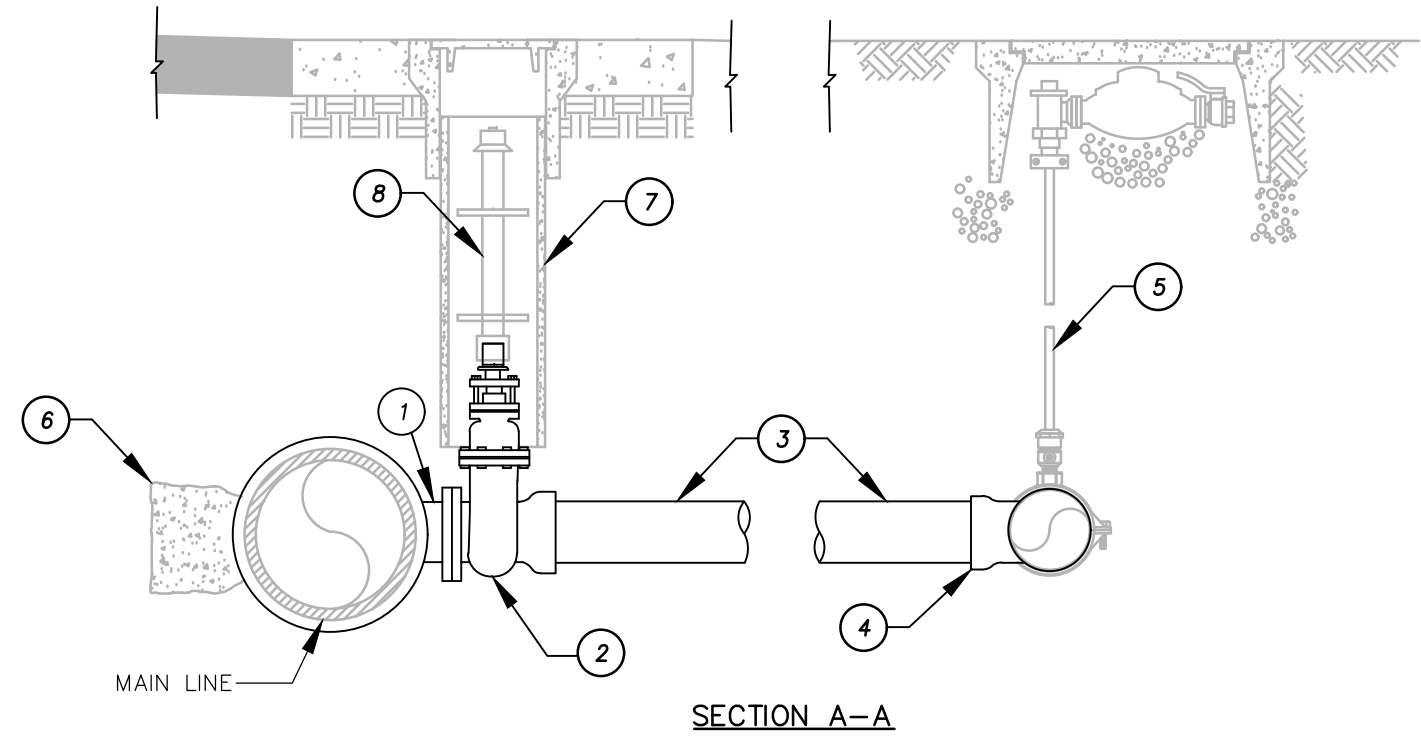
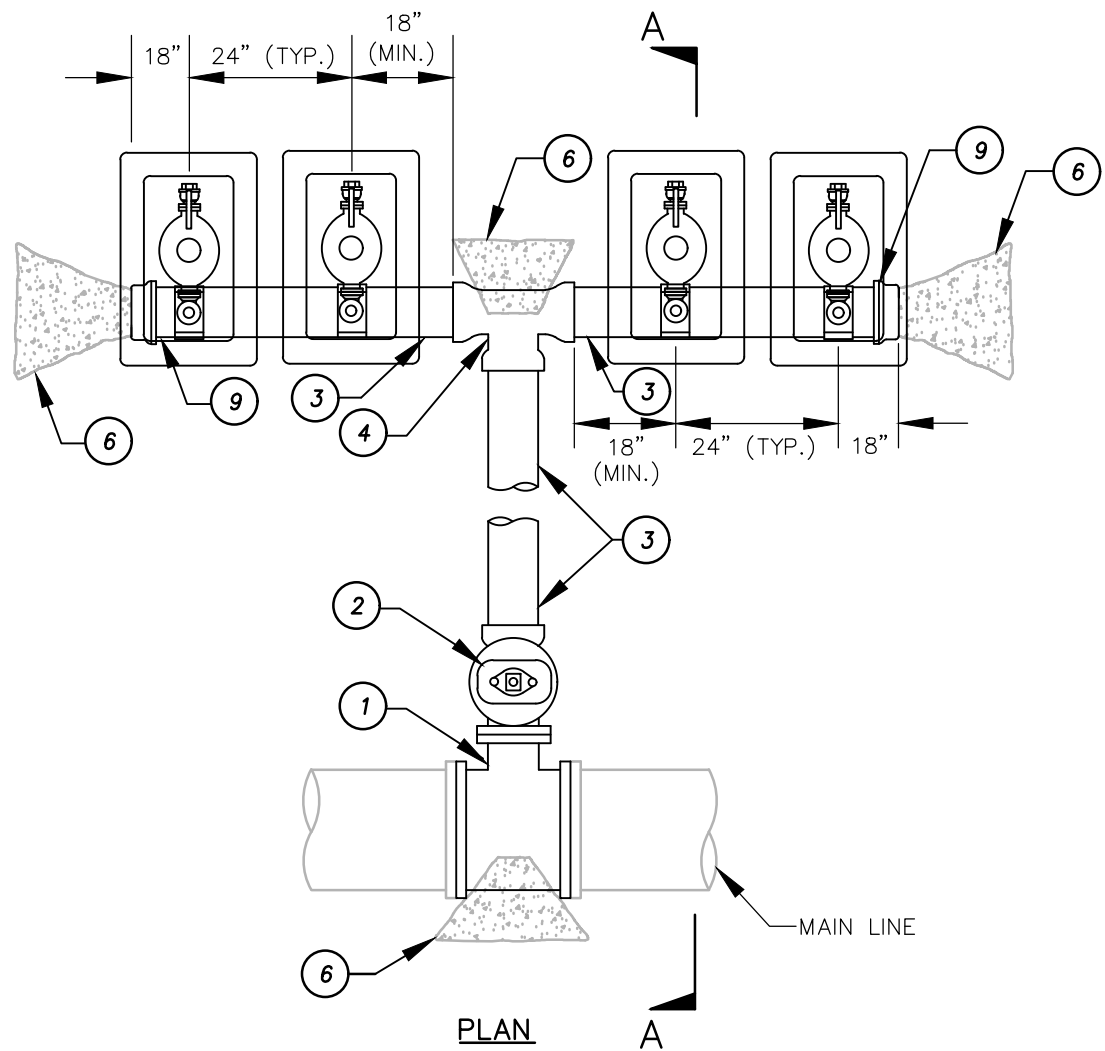

ITEM	MATERIALS
1	MAIN SIZE X 4" D.I. TEE, F.E. X F.E.
2	4" RW GATE VALVE, F.E. X P.O. SEE NOTE 3.
3	4" C-900 PVC PIPE, DR 14.
4	4" X 4" D.I. TEE, P.O. X P.O.
5	1" OR 2" SERVICE PER IRWD STD. DWG. W-1 AND W-2.
6	THRUST BLOCK PER IRWD STD. DWG. W-16.
7	VALVE BOX PER IRWD STD. DWG. W-22.
8	VALVE STEM EXTENSION PER IRWD STD. DWG. W-23, WHERE APPLICABLE.
9	4" D.I. P.O. CAP.

NOTES:

- THIS ASSEMBLY SHALL NOT BE USED FOR FEWER THAN 4 OR MORE THAN 10 SERVICE CONNECTIONS UNLESS PREVIOUSLY APPROVED BY IRWD.
- SERVICE CONNECTIONS FOR FIRE SPRINKLER SYSTEMS SHALL NOT BE PERMITTED ON THE MANIFOLD.
- ISOLATION VALVE TYPE CHANGES FROM GATE TO BUTTERFLY FOR SYSTEM PRESSURES OVER 100 PSI.
- WHEN MAIN LINE IS ORIENTED AT A 90 DEGREE ANGLE, AN END OF LINE FLUSH-OUT SHALL BE REQUIRED PER IRWD STD. DWG. W-13.

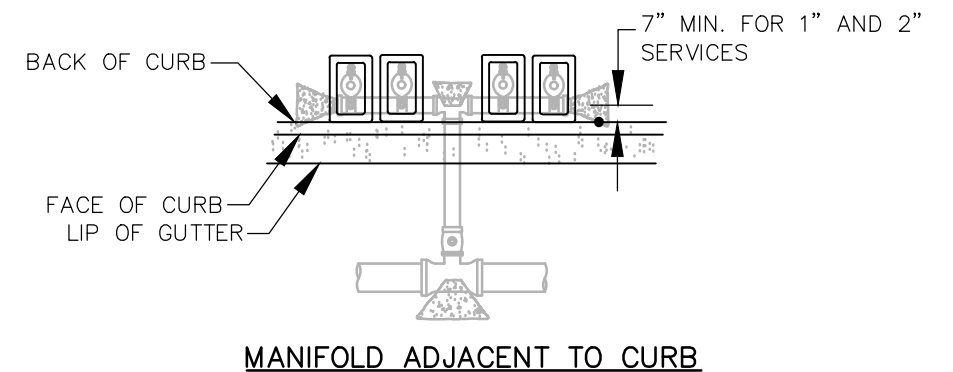
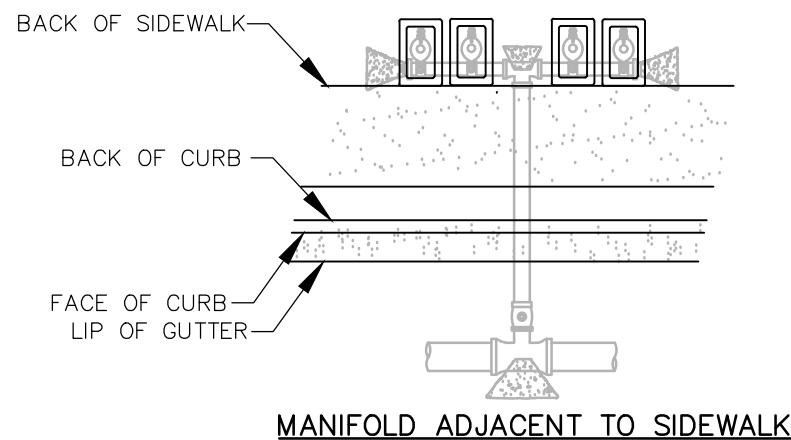

1" OR 2" SERVICE MANIFOLD

IRVINE RANCH WATER DISTRICT, ENGINEERING DEPARTMENT
 APPROVED BY:
Kevin L. Burton
 KEVIN L. BURTON R.M.E. M28832
 EXECUTIVE DIRECTOR, TECHNICAL SERVICES

FEBRUARY 2025
 REVISION



**IRWD
 STD. DWG.
 W-4**
 NOT TO SCALE
 SHEET 1 OF 1

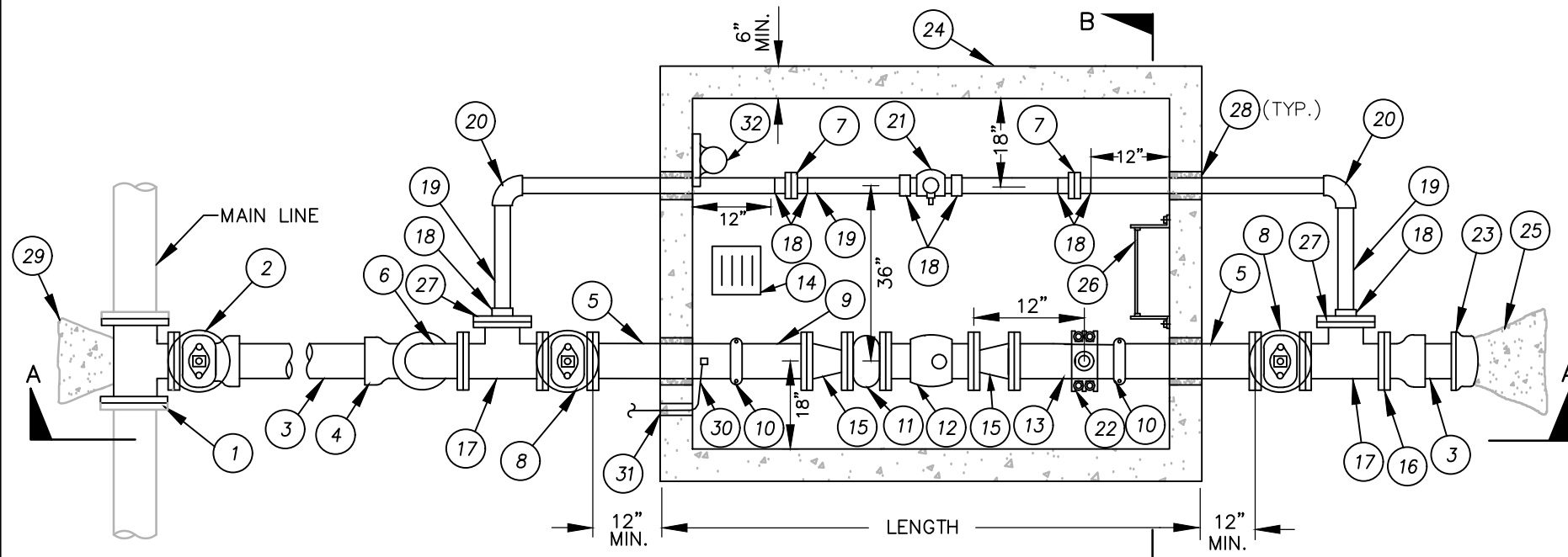

ITEM	MATERIALS
1	MAIN LINE SIZE X 4" TEE WITH FLANGED OUTLET.
2	4" RW GATE VALVE, F.E. X P.O.
3	4" C-900 PVC DR 14 PIPE.
4	4" 90° D.I. BEND, P.O. X F.E.
5	4" X D.I. SPINDLE (LENGTH AS REQUIRED), F.E. X G.E.
6	4" 90° D.I. BEND, F.E. X F.E.
7	CL 150 THREADED BRONZE COMPANION FLANGE WITH 316 SS HARDWARE.
8	4" RW GATE VALVE, F.E. X F.E.
9	4" D.I. SPINDLE, F.E. X G.E., LENGTH AS REQUIRED.
10	G.E. COUPLING. HEAVY DUTY STYLE 77 WITH 316 SS HARDWARE.
11	METER STRAINER, F.E. X F.E.
12	METER, SINGLE-JET OR TURBINE, SEE NOTE 6.
13	4" D.I. SPINDLE, F.E. X G.E. (LENGTH AS REQUIRED FOR 3" SERVICE).
14	12" X 12" X 18" RECESSED SUMP WITH 1" THICK FIBERGLASS GRATE INLET.
15	4" X 3" D.I. REDUCER, F.E. X F.E. (FOR 3" METER ONLY)
16	4" F.E. X P.O. ADAPTER.
17	4" X 4" D.I. TEE, F.E. X F.E.
18	2" WROT COPPER ADAPTER, M.I.P.T X SLIP.
19	2" TYPE "K" RIGID COPPER PIPE (LENGTH AS REQUIRED).
20	2" 90° BEND WROT COPPER, SLIP X SLIP.
21	2" TEFLON SEATED BRASS BALL VALVE WITH LOCKING WING, F.I.P.T. X F.I.P.T.
22	2" SERVICE SADDLE WITH DOUBLE STAINLESS STEEL STRAPS, NYLON COATED MALEABLE IRON BODY AND 2" F.I.P.T. OUTLET PER IRWD STD. DWG. W-3, SHEET 4.
23	4" D.I. P.O. END CAP (WHERE ON-SITE PIPING IS NOT CONNECTED). SEE NOTE 7.
24	PRECAST CONCRETE VAULT WITH SPRING-ASSIST OPEN HATCH. PROVIDE DIAMOND PLATE ALUMINUM ACCESS DOORS WITH RECESSED PADLOCK HASP FOR #5 LOCK (ON OPPOSITE END OF VAULT FROM LADDER) AND VAULT HATCH CHANNEL DRAIN (PLUMB TO CRUSHED ROCK). SEE NOTE 5 FOR VAULT SIZE.
25	THRUST BLOCK PER IRWD STD. DWG. W-16 (WHERE ON-SITE PIPING IS NOT CONNECTED). REMOVE FOR PERMANENT CONNECTION.
26	VAULT LADDER PER IRWD STD. DWG. G-5.
27	4" X 2" BRASS COMPANION FLANGE WITH F.I.P.T. OUTLET.
28	LINK-SEAL MODULAR SEAL MODEL "C" WITH EPDM AND STAINLESS STEEL HARDWARE PER IRWD STD. DWG. G-8 AND G-9.
29	THRUST BLOCK PER IRWD STD. DWG. W-16.
30	AWG NO. 8 STRANDED COPPER ANODE LEAD WIRE, PROVIDE AND CONNECT TO SHUNT, LEAVE 36" OF COILED WIRE BEFORE SHUNT IN VAULT. ALUMINO-THERMIC WELD PER IRWD STD. SPEC. SECTION 16640 AND IRWD STD. DWG. CP-8 AND CP-9.
31	AWG NO. 8 STRANDED COPPER ANODE LEAD WIRE. CORE DRILL VAULT AND SEAL PER IRWD STD. DWG. G-8.
32	3M DBI-SALA WALL MOUNTED SLEEVE DAVIT BASE, MODEL #8518348. SEE IRWD STD. DWG. W-15 SHEET 3 OF 15.

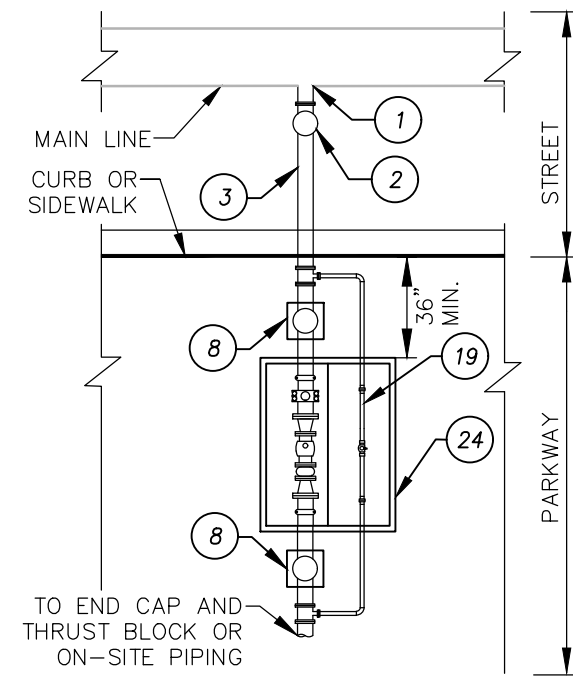

CASE 1

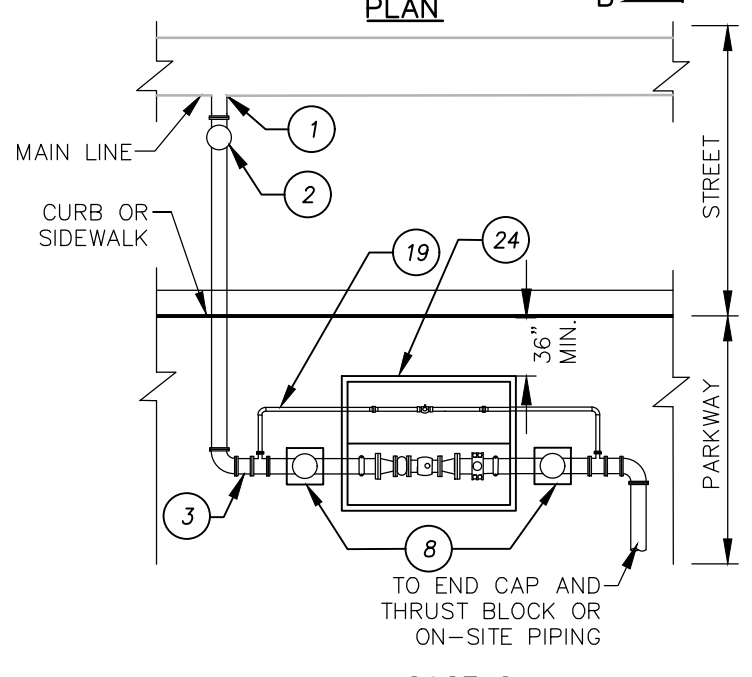

CASE 2

METER ASSEMBLY LOCATION PLANS

NOTES:

- EASEMENT: METER INSTALLATION IMPROVEMENTS BEYOND THE CITY OR COUNTY RIGHT-OF-WAY REQUIRE AN EASEMENT AS DIRECTED BY IRWD.
- RETAINING WALL: WHEN A RETAINING WALL IS REQUIRED TO ACCOMMODATE GRADE VARIATIONS, THE WALL SHALL BE CONSTRUCTED PER IRWD STD. DWG. G-4 AND SHOULD PROVIDE PROPER CLEARANCE FROM THE IMPROVEMENTS.
- VAULTS: VAULTS SHALL BE CONSTRUCTED A MIN. 36" AWAY FROM CURB OR SIDEWALK, LEVEL, AND DESIGNED BY THE ENGINEER OF RECORD TO ACCOUNT FOR NUISANCE WATER AND THE SAFETY OF THE TRAVELING PUBLIC.
- AT NO POINT SHALL ANY PART OF THE METER ASSEMBLY BE CLOSER THAN 36" AWAY FROM ANY STRUCTURE OR LANDSCAPING.
- PRECAST VAULT INSIDE DIMENSIONS SHALL BE 6' X 6'.
- METERS, FLANGE INSULATING KITS, NUTS, BOLTS, AND WASHERS PROVIDED BY IRWD.
- SEE IRWD STD. DWG. W-12 FOR TEMPORARY FLUSH-OUT REQUIRED TO CONDUCT HYDROSTATIC TESTING AND CHLORINATION.

3" AND 4" METER ASSEMBLY - PLAN VIEW

IRVINE RANCH WATER DISTRICT, ENGINEERING DEPARTMENT
 APPROVED BY:

 KEVIN L. BURTON R.M.E. M28832
 EXECUTIVE DIRECTOR, TECHNICAL SERVICES

FEBRUARY 2025
 REVISION



**IRWD
 STD. DWG.
 W-5**
 NOT TO SCALE
 SHEET 1 OF 4

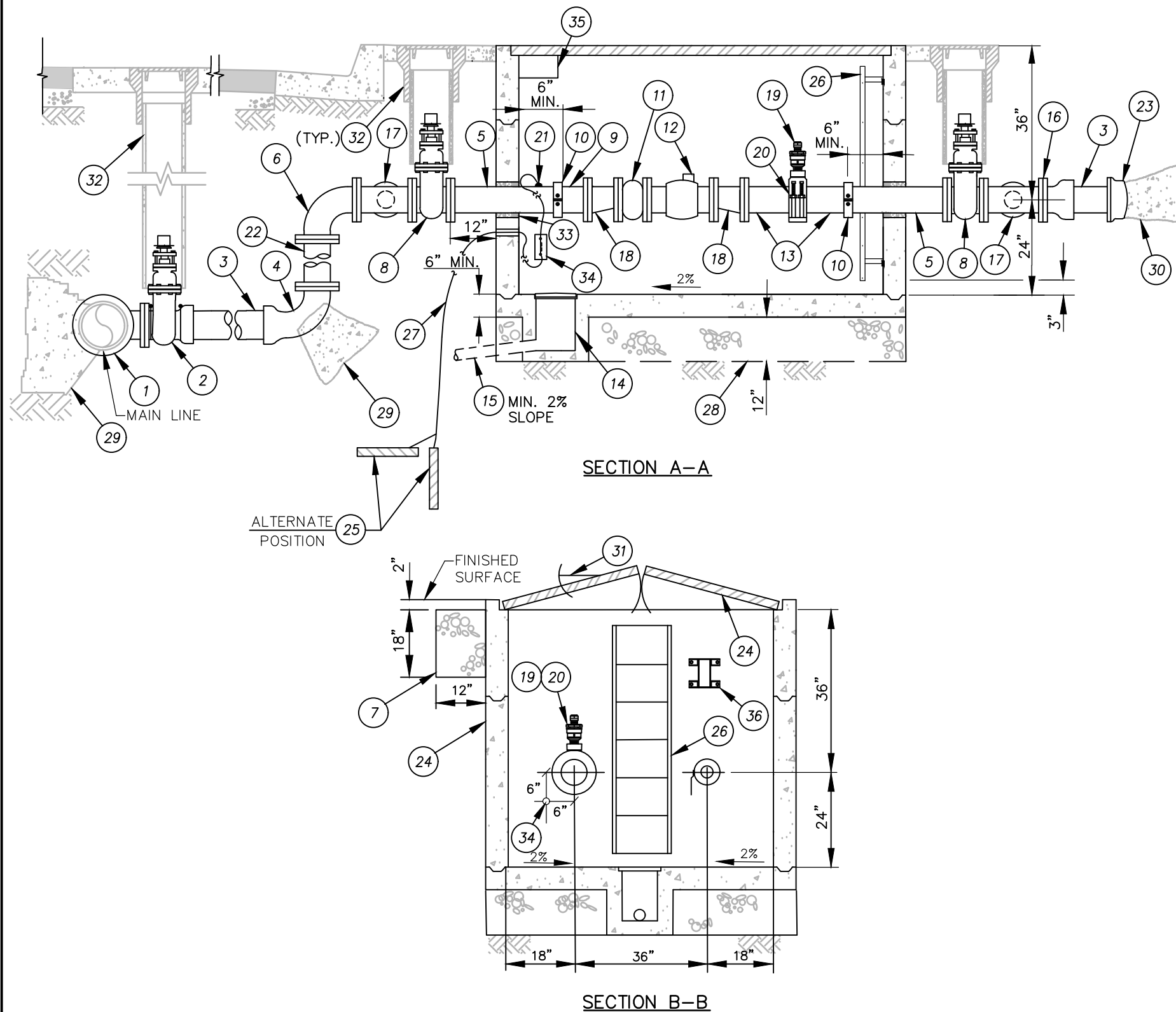

- | ITEM | MATERIALS |
|------|---|
| 1 | MAIN LINE SIZE X 4" TEE WITH FLANGED OUTLET. |
| 2 | 4" RW GATE VALVE, F.E. X P.O. |
| 3 | 4" C-900 PVC DR 14 PIPE. |
| 4 | 4" 90° D.I. BEND, P.O. X F.E. |
| 5 | 4" X D.I. SPINDLE (LENGTH AS REQUIRED), F.E. X G.E. |
| 6 | 4" 90° D.I. BEND, F.E. X F.E. |
| 7 | 18" OF 3/4" CRUSHED ROCK FOR CHANNEL DRAIN. |
| 8 | 4" RW GATE VALVE, F.E. X F.E. |
| 9 | 4" D.I. SPINDLE, F.E. X G.E. (LENGTH AS REQUIRED). |
| 10 | G.E. COUPLING. HEAVY DUTY STYLE 77 WITH 316 SS HARDWARE. |
| 11 | METER STRAINER, F.E. X F.E. |
| 12 | METER, SINGLE-JET OR TURBINE. SEE NOTE 3. |
| 13 | 4" LONG D.I. SPINDLE, F.E. X G.E. (LENGTH AS REQUIRED FOR 3" SERVICE). |
| 14 | 12" X 12" X 18" RECESSED SUMP WITH 1" THICK FIBERGLASS GRATE INLET. |
| 15 | 4" SCH 80 PVC DRAIN PIPE. CONNECT TO STORM DRAINAGE SYSTEM ACCEPTABLE TO IRWD. SEE ALSO IRWD STD. DWG. G-6. |
| 16 | 4" F.E. X P.O. ADAPTER. |
| 17 | 4" X 4" D.I. TEE, F.E. X F.E. |
| 18 | 4" X 3" D.I. ECCENTRIC REDUCER F.E. X F.E. (FOR 3" METER ONLY). |
| 19 | 2" BALL CORPORATION STOP, BRASS M.I.P.T. X M.I.P.T., 2" F.I.P.T. X 2-1/2" M.F.H.T. AND 2-1/2" HYDRANT CAP. |
| 20 | 2" SERVICE SADDLE WITH DOUBLE STAINLESS STEEL STRAPS, NYLON COATED MALEABLE IRON BODY AND 2" F.I.P.T. OUTLET PER IRWD STD. DWG. W-3, SHEET 4. |
| 21 | AWG NO. 8 STRANDED COPPER ANODE LEAD WIRE. ALUMINO-THERMIC WELD PER IRWD STD. SPEC. SECTION 16640 AND IRWD STD. DWG. CP-8 AND CP-9. |
| 22 | 4" D.I. SPOOL, F.E. X F.E. (LENGTH AS REQUIRED TO MAKE EXACT GRADES). |
| 23 | 4" D.I. P.O. END CAP. (WHERE ON-SITE PIPING IS NOT CONNECTED). SEE NOTE 4. |
| 24 | PRECAST CONCRETE VAULT WITH SPRING-ASSIST OPEN HATCH. PROVIDE DIAMOND PLATE ALUMINUM ACCESS DOORS AND VAULT HATCH CHANNEL DRAIN (PLUMB TO CRUSHED ROCK). SEE NOTE 5 ON SHEET 1 OF 4 FOR VAULT SIZE. |
| 25 | 30 POUND ZINC ANODE AND LEAD WIRE. ANODE TO BE PLACED VERTICALLY OR HORIZONTALLY AT A MIN. SEPARATION OF 24" FROM THE PIPING. |
| 26 | VAULT LADDER PER IRWD STD. DWG. G-5. |
| 27 | AWG NO. 8 STRANDED COPPER ANODE LEAD WIRE. CORE DRILL VAULT AND SEAL WITH SIKAFLEX PER IRWD STD. DWG. G-8. |
| 28 | 12" OF 3/4" CRUSHED ROCK BASE. |
| 29 | THRUST BLOCK PER IRWD STD. DWG. W-16. |
| 30 | THRUST BLOCK PER IRWD STD. DWG. W-16 (WHERE ON-SITE PIPING IS NOT CONNECTED). REMOVE FOR PERMANENT CONNECTION. |
| 31 | 6" X 12" HINGED READING LID OVER METER REGISTER. |
| 32 | VALVE BOX, PER IRWD STD. DWG. W-22. |
| 33 | LINK-SEAL MODULAR SEAL MODEL "C" WITH EPDM AND STAINLESS STEEL HARDWARE. SEE IRWD STD. DWG. G-8 AND G-9. |
| 34 | BRASS SHUNT WITH PLASTIC BASE, BY FARWEST CORROSION OR MESA PRODUCTS. MOUNT SHUNT TO WALL WITH 4" RED HEAD 316 SS ANCHORS. LEAVE 36" OF COILED WIRE ON EACH SIDE OF SHUNT. |
| 35 | ALUMINUM ENCLOSURE WITH RECESSED PADLOCK HASP FOR #5 LOCK (ON OPPOSITE END OF VAULT FROM LADDER). |
| 36 | 3M DBI-SALA WALL MOUNTED SLEEVE DAVIT BASE, MODEL #8518348. SEE IRWD STD. DWG. W-15 SHEET 3 OF 15. |

NOTES:

- WHERE VAULTS ARE OFFSET FROM CURB OR SIDEWALK, OR PLACED IN PARKWAYS, SET HATCH 2" ABOVE FINISHED SURFACE.
- AT NO POINT SHALL ANY PART OF THE METER ASSEMBLY VAULT BE CLOSER THAN 36" AWAY FROM ANY STRUCTURE OR LANDSCAPING.
- METERS, FLANGE INSULATING KITS, NUTS, BOLTS, AND WASHERS PROVIDED BY IRWD.
- SEE IRWD STD. DWG. W-12 FOR TEMPORARY FLUSH-OUT REQUIRED TO CONDUCT HYDROSTATIC TESTING AND CHLORINATION.

3' AND 4' METER ASSEMBLY - SECTIONS

IRVINE RANCH WATER DISTRICT, ENGINEERING DEPARTMENT

APPROVED BY:

Kevin L. Burton
 KEVIN L. BURTON R.M.E. M28832
 EXECUTIVE DIRECTOR, TECHNICAL SERVICES

FEBRUARY 2025
 REVISION



**IRWD
 STD. DWG.
 W-5**

NOT TO SCALE
 SHEET 2 OF 4

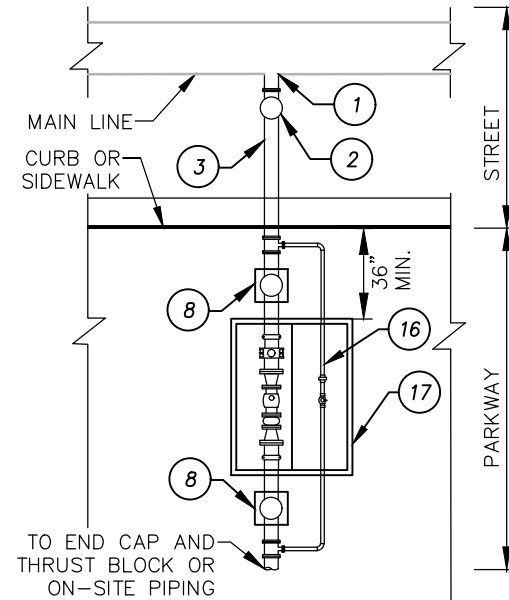
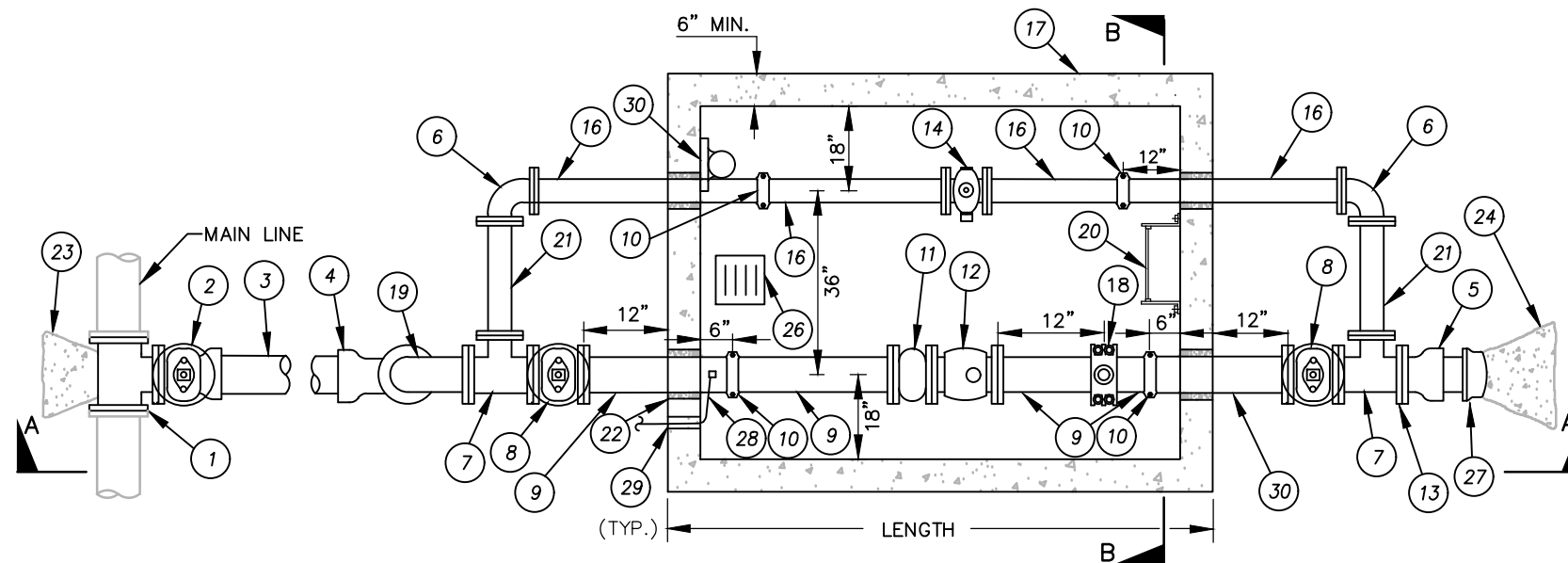

CASE 1

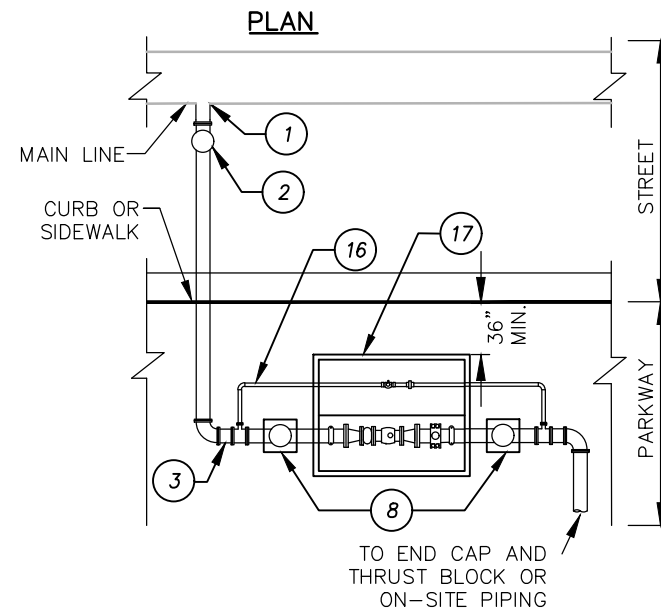

CASE 2

METER ASSEMBLY LOCATION PLANS

NOTES:

1. EASEMENT: METER INSTALLATION IMPROVEMENTS BEYOND THE CITY OR COUNTY RIGHT-OF-WAY REQUIRE AN EASEMENT AS DIRECTED BY IRWD.
2. RETAINING WALL: WHEN RETAINING WALL IS REQUIRED TO ACCOMMODATE GRADE VARIATIONS, THE WALL SHALL BE CONSTRUCTED PER IRWD STD. DWG. G-4 AND SHOULD PROVIDE PROPER CLEARANCE FROM THE IMPROVEMENTS.
3. VAULTS: VAULTS ADJACENT TO CURB OR SIDEWALK WITH A CROSS SLOPE OF 3% OR GREATER SHALL BE CONSTRUCTED A MIN. 24" AWAY FROM CURB OR SIDEWALK, LEVEL, AND DESIGNED BY THE ENGINEER OF RECORD TO ACCOUNT FOR NUISANCE WATER AND THE SAFETY OF THE TRAVELING PUBLIC.
4. AT NO POINT SHALL ANY PART OF THE METER ASSEMBLY BE CLOSER THAN 36" AWAY FROM ANY STRUCTURE OR LANDSCAPING.
5. PRECAST VAULT INSIDE DIMENSIONS SHALL BE 8' X 6'.
6. METERS, FLANGE INSULATING KITS, NUTS, BOLTS, AND WASHERS PROVIDED BY IRWD.
7. SEE IRWD STD. DWG. W-12 FOR TEMPORARY FLUSH-OUT REQUIRED TO CONDUCT HYDROSTATIC TESTING AND CHLORINATION.

ITEM MATERIALS

- 1 MAIN LINE SIZE X METER SIZE TEE WITH FLANGED OUTLET.
- 2 METER SIZE RW GATE VALVE, F.E. X P.O.
- 3 METER SIZE C-900 PVC DR 14 PIPE.
- 4 METER SIZE 90° D.I. BEND, P.O. X F.E.
- 5 METER SIZE C-900 PVC DR 14 PIPE, 30" LONG.
- 6 4" 90° D.I. BEND, F.E. X F.E.
- 7 METER SIZE X 4" D.I. TEE, F.E. X F.E.
- 8 METER SIZE RW GATE VALVE, F.E. X F.E.
- 9 METER SIZE X D.I. SPINDLE (LENGTH AS REQUIRED), F.E. X G.E.
- 10 G.E. COUPLING, HEAVY DUTY STYLE 77 WITH 316 SS HARDWARE.
- 11 METER STRAINER, F.E. X F.E.
- 12 METER, SINGLE JET OR TURBINE. SEE NOTE 6.
- 13 METER SIZE F.E. X P.O. D.I. ADAPTER.
- 14 4" GATE VALVE WITH LOCKING CAP, F.E. X F.E.
- 15 NOT USED.
- 16 4" D.I. SPINDLE, F.E. X G.E. (LENGTH AS REQUIRED).
- 17 PRECAST CONCRETE VAULT WITH SPRING-ASSIST OPEN HATCH. PROVIDE DIAMOND PLATE ALUMINUM ACCESS DOORS WITH RECESSED PADLOCK HASP FOR #5 LOCK (ON OPPOSITE END OF VAULT FROM LADDER) AND VAULT HATCH CHANNEL DRAIN (PLUMB TO CRUSHED ROCK). SEE NOTE 5 FOR VAULT SIZE.
- 18 2" SERVICE SADDLE WITH DOUBLE STAINLESS STEEL STRAPS, NYLON COATED MALEABLE IRON BODY AND 2" F.I.P.T. OUTLET PER IRWD STD. DWG. W-3, SHEET 4.
- 19 METER SIZE 90° D.I. BEND, F.E. X F.E.
- 20 VAULT LADDER PER IRWD STD. DWG. G-5.
- 21 4" D.I. SPOOL F.E. X F.E., LENGTH 21-1/2" FOR 6" DIA., 20-1/2" FOR 8" DIA., 18-1/2" FOR 10" DIA.
- 22 LINK-SEAL MODULAR SEAL MODEL "C" WITH EPDM AND STAINLESS STEEL HARDWARE PER IRWD STD. DWG. G-9.
- 23 THRUST BLOCK PER IRWD STD. DWG. W-16.
- 24 THRUST BLOCK PER IRWD STD. DWG. W-16 (WHERE ON-SITE PIPING IS NOT CONNECTED). REMOVE FOR PERMANENT CONNECTION.
- 25 NOT USED.
- 26 12" X 12" X 18" RECESSED SUMP WITH 1" THICK FIBERGLASS GRATE INLET.
- 27 METER SIZE D.I. END CAP, P.O. (WHERE ON-SITE PIPING IS NOT CONNECTED). SEE NOTE 7.
- 28 AWG NO. 8 STRANDED COPPER ANODE LEAD WIRE, PROVIDE AND CONNECT TO SHUNT, LEAVE 36" OF COILED WIRE BEFORE SHUNT IN VAULT. ALUMINO-THERMIC WELD PER IRWD STD. SPEC. SECTION 16640 AND IRWD STD. DWG. CP-8 AND CP-9.
- 29 AWG NO. 8 STRANDED COPPER ANODE LEAD WIRE. CORE DRILL VAULT AND SEAL PER IRWD STD. DWG. G-8.
- 30 3M DBI-SALA WALL MOUNTED SLEEVE DAVIT BASE, MODEL #8518348. SEE IRWD STD. DWG. W-15 SHEET 3 OF 15.

6", 8", AND 10" METER ASSEMBLY - PLAN VIEW

IRVINE RANCH WATER DISTRICT, ENGINEERING DEPARTMENT

APPROVED BY:

Kevin L. Burton

KEVIN L. BURTON R.M.E. M28832
EXECUTIVE DIRECTOR, TECHNICAL SERVICES

FEBRUARY 2025

REVISION



Irvine Ranch
WATER DISTRICT

**IRWD
STD. DWG.
W-5**

NOT TO SCALE
SHEET 3 OF 4

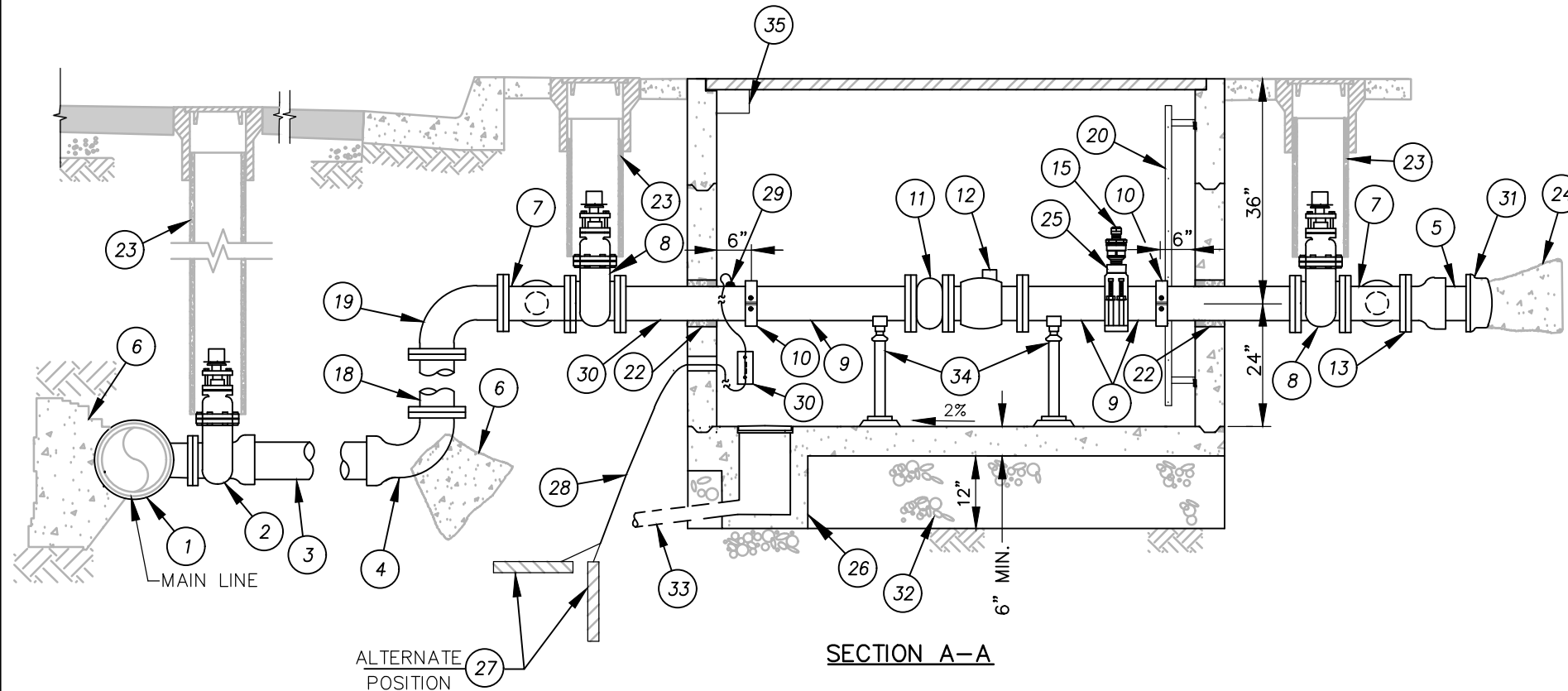

SECTION A-A

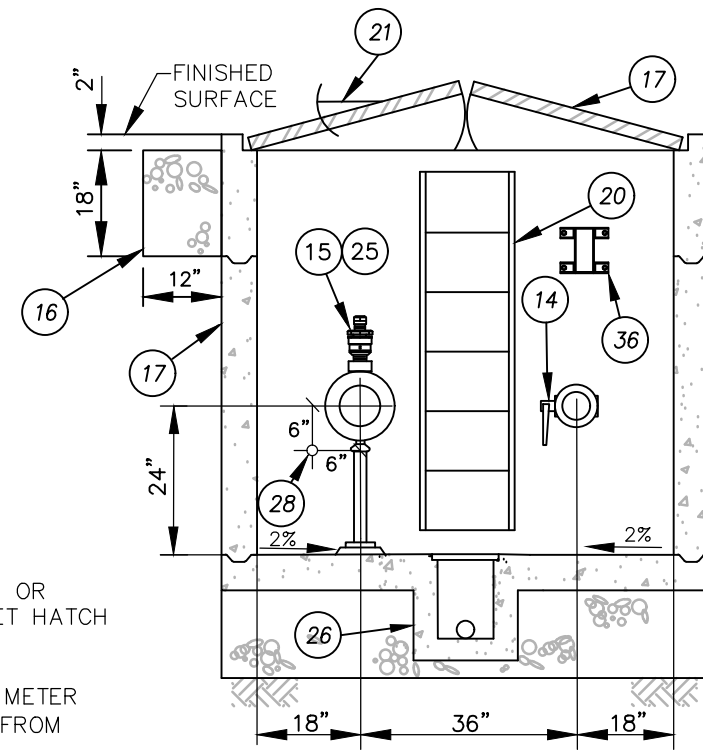

SECTION B-B

ITEM	MATERIALS
1	MAIN LINE SIZE X 4" TEE WITH FLANGED OUTLET.
2	METER SIZE RW GATE VALVE, F.E. X P.O.
3	METER SIZE C-900 PVC DR 14 PIPE.
4	METER SIZE 90° D.I. BEND, P.O. X F.E.
5	METER SIZE C-900 PVC DR 14 PIPE, 30" LONG.
6	THRUST BLOCK PER IRWD STD. DWG. W-16.
7	METER SIZE X 4" D.I. TEE, F.E. X F.E.
8	METER SIZE RW GATE VALVE, F.E. X F.E.
9	METER SIZE X D.I. SPINDLE (LENGTH AS REQUIRED), F.E. X G.E.
10	G.E. COUPLING, HEAVY DUTY STYLE 77 WITH STAINLESS STEEL HARDWARE.
11	METER STRAINER, F.E. X F.E.
12	METER, SINGLE JET OR TURBINE. SEE NOTE 3.
13	METER SIZE D.I. F.E. X P.O. ADAPTER.
14	4" GATE VALVE WITH LOCKING CAP, F.E. X F.E.
15	2" BALL CORPORATION STOP, M.I.P.T. X M.I.P.T., 2" F.I.P.T. X 2-1/2" M.F.H.T. AND 2-1/2" BRASS HYDRANT CAP.
16	18" OF 3/4" CRUSHED ROCK FOR CHANNEL DRAIN.
17	PRECAST CONCRETE VAULT WITH SPRING-ASSIST OPEN HATCH. PROVIDE DIAMOND PLATE ALUMINUM ACCESS DOORS AND VAULT HATCH CHANNEL DRAIN (PLUMB TO CRUSHED ROCK). SEE NOTE 5 ON SHEET 3 OF 4 FOR VAULT SIZE.
18	METER SIZE X D.I. SPOOL, F.E. X F.E. (LENGTH AS REQUIRED TO MAKE EXACT GRADE).
19	METER SIZE 90° D.I. BEND, F.E. X F.E.
20	VAULT LADDER PER IRWD STD. DWG. G-5.
21	6" X 12" HINGED READING LID OVER METER REGISTER.
22	LINK-SEAL MODULAR SEAL MODEL "C" WITH EPDM AND STAINLESS STEEL HARDWARE. SEE IRWD STD. DWG. G-8 AND G-9.
23	VALVE BOX, PER IRWD STD. DWG. W-22.
24	THRUST BLOCK PER IRWD STD. DWG. W-16 (WHERE ON-SITE PIPING IS NOT CONNECTED). REMOVE FOR PERMANENT CONNECTION.
25	2" SERVICE SADDLE WITH DOUBLE STAINLESS STEEL STRAPS, NYLON COATED MALEABLE IRON BODY AND 2" F.I.P.T. OUTLET PER IRWD STD. DWG. W-3, SHEET 4.
26	12" X 12" X 18" RECESSED SUMP WITH 1" THICK FIBERGLASS GRATE INLET.
27	30 POUND ZINC ANODE AND LEAD WIRE. ANODE TO BE PLACED VERTICALLY OR HORIZONTALLY AT A MIN. SEPARATION OF 24" FROM THE PIPING.
28	AWG NO. 8 STRANDED COPPER ANODE LEAD WIRE. CORE DRILL VAULT AND SEAL PER IRWD STD. DWG. G-8.
29	AWG NO. 8 STRANDED COPPER ANODE LEAD WIRE, ALUMINO-THERMIC WELD PER IRWD STD. SPEC. SECTION 16640 AND IRWD STD. DWG. CP-8 AND CP-9.
30	BRASS SHUNT WITH PLASTIC BASE, BY FARWEST CORROSION OR MESA PRODUCTS. MOUNT SHUNT TO WALL WITH 4" RED HEAD 316 SS ANCHORS. LEAVE 36" OF COILED WIRE ON EACH SIDE OF SHUNT.
31	METER SIZED D.I. END CAP, P.O. (WHERE ON-SITE PIPING IS NOT CONNECTED). SEE NOTE 4.
32	12" OF 3/4" CRUSHED ROCK BASE.
33	4" SCH 80 PVC DRAIN PIPE. CONNECT TO STORM DRAINAGE SYSTEM ACCEPTABLE TO IRWD. SEE IRWD STD. DWG. G-6.
34	ADJUSTABLE PIPE SUPPORT FOR ASSEMBLIES 8" DIA. AND LARGER PER IRWD STD. DWG. W-24.
35	ALUMINUM ENCLOSURE WITH RECESSED PADLOCK HASP FOR #5 LOCK (ON OPPOSITE END OF VAULT FROM LADDER).
36	3M DBI-SALA WALL MOUNTED SLEEVE DAVIT BASE, MODEL #8518348. SEE IRWD STD. DWG. W-15 SHEET 3 OF 15.

NOTES:

- WHERE VAULTS ARE OFFSET FROM CURB OR SIDEWALK, OR PLACED IN PARKWAYS, SET HATCH 2" ABOVE FINISHED SURFACE.
- AT NO POINT SHALL ANY PART OF THE METER ASSEMBLY BE CLOSER THAN 36" AWAY FROM ANY STRUCTURE OR LANDSCAPING.
- METERS, FLANGE INSULATING KITS, NUTS, BOLTS, AND WASHERS PROVIDED BY IRWD.
- SEE IRWD STD. DWG. W-12 FOR TEMPORARY FLUSH-OUT REQUIRED TO CONDUCT HYDROSTATIC TESTING AND CHLORINATION.

6", 8", AND 10" METER ASSEMBLY - SECTIONS

IRVINE RANCH WATER DISTRICT, ENGINEERING DEPARTMENT
 APPROVED BY:

 KEVIN L. BURTON R.M.E. M28832
 EXECUTIVE DIRECTOR, TECHNICAL SERVICES

FEBRUARY 2025
 REVISION

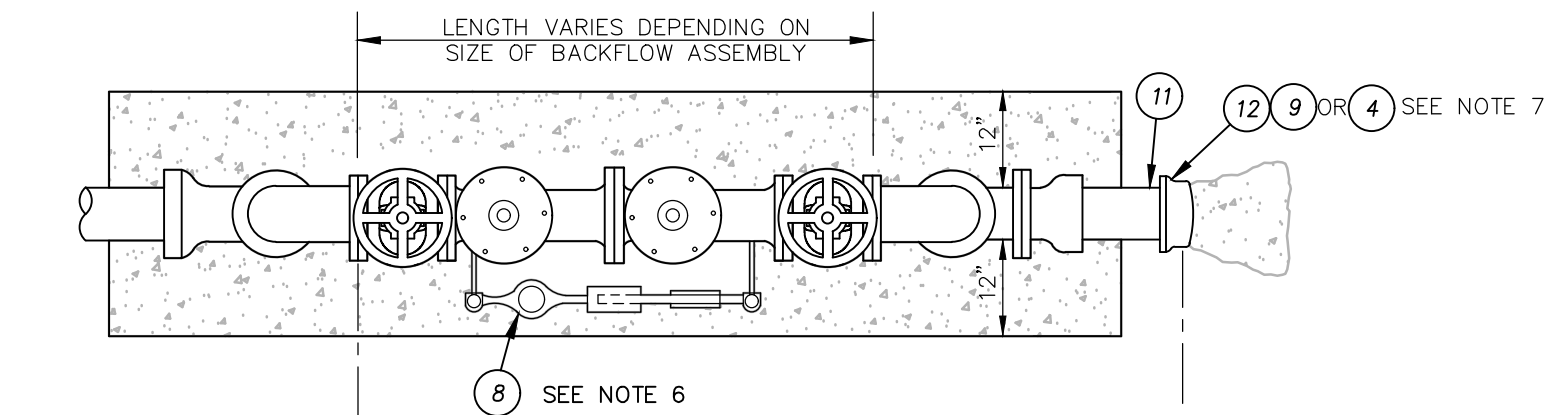
 Irvine Ranch WATER DISTRICT	IRWD STD. DWG. W-5
	NOT TO SCALE SHEET 4 OF 4

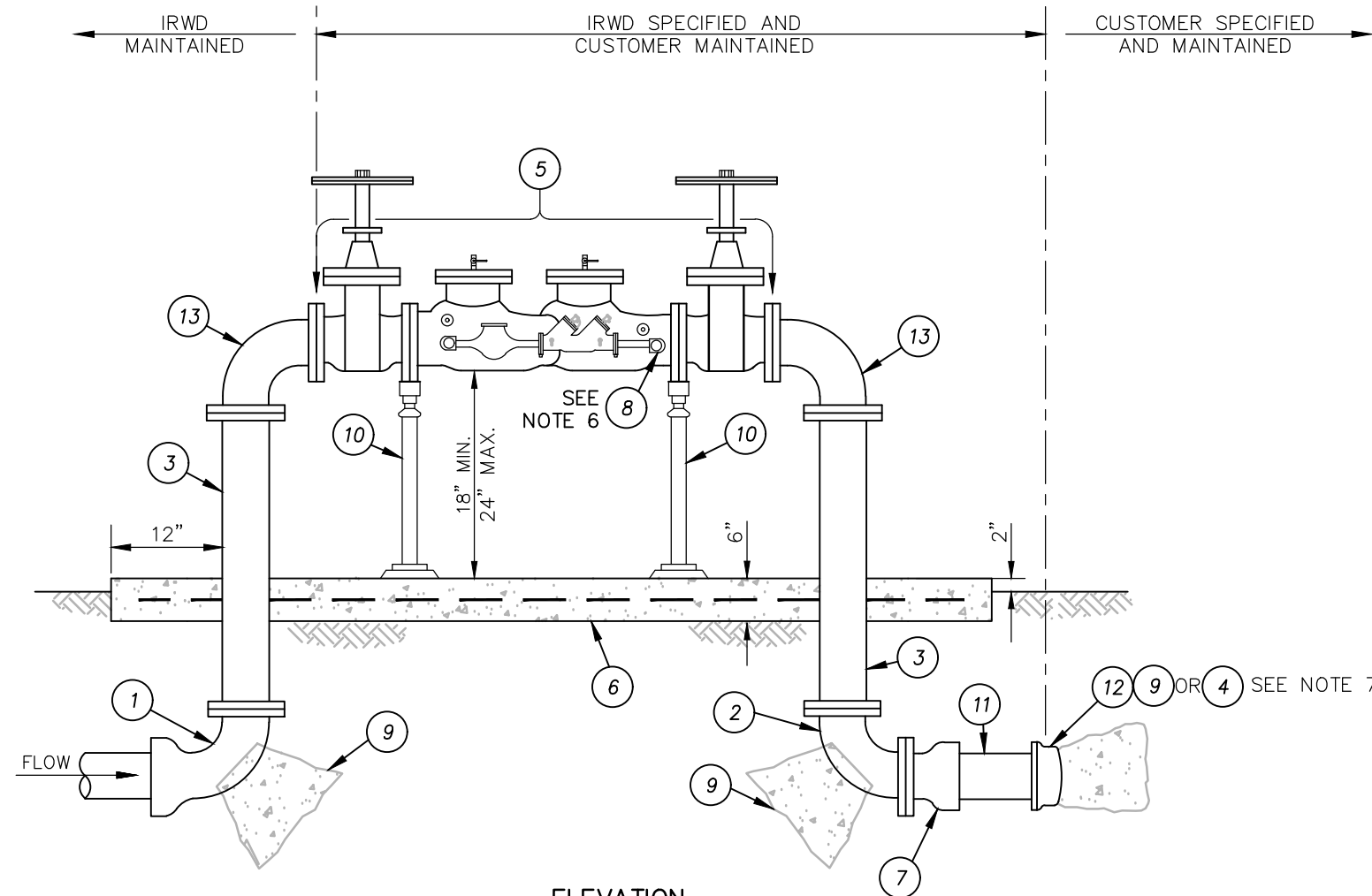

PLAN



ELEVATION

ITEM MATERIALS

- 1 — D.I. 90° BEND, F.E. X P.O.
- 2 — D.I. 90° BEND, F.E. X F.E.
- 3 — D.I. SPOOL, F.E. X F.E., LENGTH AS REQUIRED.
- 4 — TRANSITION COUPLING (BY OTHERS, FOR ON-SITE CONNECTION WHEN ON-SITE PIPING EXISTS).
- 5 — APPROVED DOUBLE CHECK VALVE BACKFLOW PREVENTION ASSEMBLY WITH RISING STEM RESILIENT WEDGE GATE VALVES, VALVES SHALL BE PROVIDED AS AN INTEGRAL PART OF BACKFLOW ASSEMBLY.
- 6 — 6" THICK P.C.C. SLAB, REINFORCE WITH W.W.F. 1.6 X 1.6.
- 7 — F.E. X P.O. ADAPTER.
- 8 — FACTORY INSTALLED BY-PASS METER ASSEMBLY CONSISTING OF APPROVED POSITIVE DISPLACEMENT METER, DOUBLE CHECK VALVE, AND ASSOCIATED PIPING. METER TO BE USED FOR FIRE SYSTEMS ONLY. METER READS IN CUBIC FEET PER IRWD STD. SPEC. SECTION 15112.
- 9 — THRUST BLOCK PER IRWD STD. DWG. W-16.
- 10 — ADJUSTABLE PIPE SUPPORT FOR ASSEMBLIES 8" DIA. AND LARGER PER IRWD STD. DWG. W-24.
- 11 — C-900 PVC DR 14 PIPE SECTION, 36" LONG.
- 12 — END CAP, P.O.
- 13 — D.I. 90° BEND, F.E. X F.E. (FOR 3" DOUBLE CHECK BACKFLOW ASSEMBLY USE 4" X 3" D.I. 90° REDUCING BEND F.E. X F.E.).

NOTES:

1. NOTIFY IRWD PRIOR TO INSTALLATION OF BACKFLOW DEVICE.
2. FIRE DEPARTMENT CONNECTION AND POST-INDICATOR VALVES SHALL NOT BE PART OF THE BACKFLOW ASSEMBLY AND MUST BE INSTALLED ON THE CUSTOMER SPECIFIED PIPING SIDE.
3. AT NO POINT SHALL ANY PART OF THE BACKFLOW DEVICE BE CLOSER THAN 36" AWAY FROM ANY STRUCTURE, FACE OF CURB, BACK OF SIDEWALK, LANDSCAPING, OR PATH OF TRAVEL.
4. BACKFLOW ASSEMBLY AND IRWD PIPING SHALL BE WITHIN A DEDICATED IRWD EASEMENT OR PUBLIC RIGHT-OF-WAY.
5. PLACE BRASS PLUGS IN ALL 3/4" VALVE OUTLETS.
6. BY-PASS METER TO BE USED FOR FIRE SYSTEMS ONLY. DO NOT INSTALL BY-PASS METERS WHERE SUPPLY TO DEVICE IS ALREADY METERED.
7. SEE IRWD STD. DWG. W-12 FOR TEMPORARY FLUSH-OUT REQUIRED TO CONDUCT HYDROSTATIC TESTING AND CHLORINATION.

DOUBLE CHECK BACKFLOW ASSEMBLY, 3" AND LARGER

IRVINE RANCH WATER DISTRICT, ENGINEERING DEPARTMENT

APPROVED BY:

Kevin L. Burton

KEVIN L. BURTON R.M.E. M28832
EXECUTIVE DIRECTOR, TECHNICAL SERVICES

FEBRUARY 2025
REVISION



**IRWD
STD. DWG.
W-6**

NOT TO SCALE
SHEET 1 OF 2

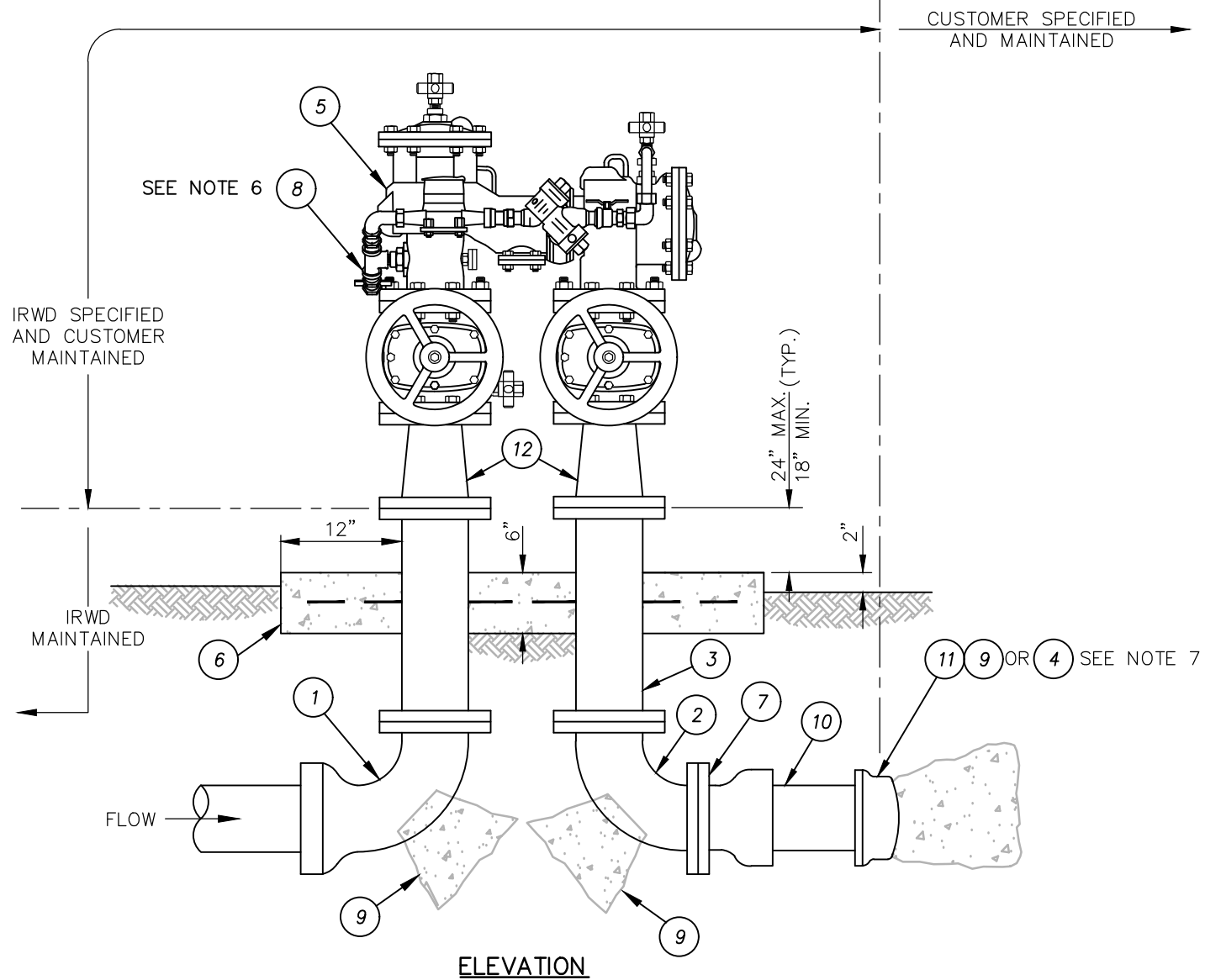
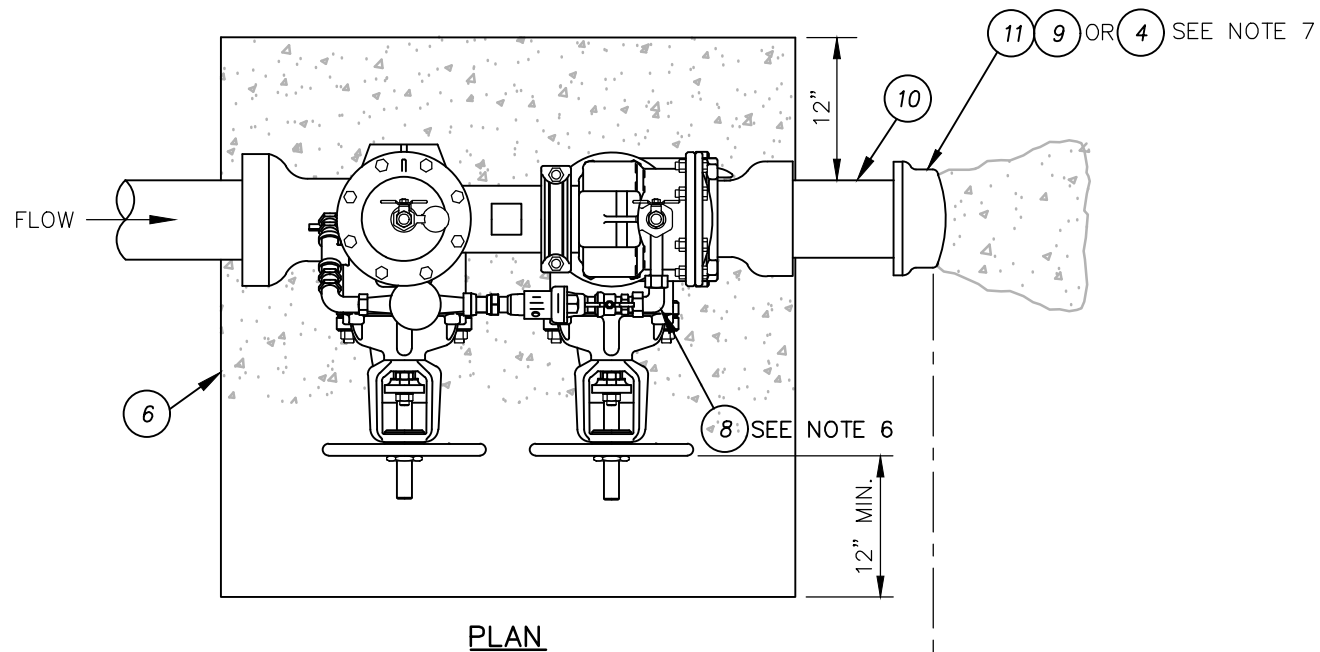

ITEM MATERIALS

- 1 — D.I. 90° BEND, F.E. X P.O.
- 2 — D.I. 90° BEND, F.E. X F.E.
- 3 — D.I. SPOOL, F.E. X F.E., LENGTH AS REQUIRED.
- 4 — TRANSITION COUPLING (BY OTHERS, FOR ON-SITE CONNECTION WHEN ON-SITE PIPING EXISTS).
- 5 — APPROVED N-PATTERN DOUBLE CHECK VALVE BACKFLOW PREVENTION ASSEMBLY WITH RISING STEM RESILIENT WEDGE GATE VALVES, VALVES SHALL BE PROVIDED AS AN INTEGRAL PART OF BACKFLOW ASSEMBLY.
- 6 — 6" THICK P.C.C. SLAB, REINFORCE WITH W.W.F. 1.6 X 1.6.
- 7 — F.E. X P.O. ADAPTER.
- 8 — FACTORY INSTALLED BY-PASS METER ASSEMBLY CONSISTING OF APPROVED POSITIVE DISPLACEMENT METER, DOUBLE CHECK VALVE, AND ASSOCIATED PIPING. METER TO BE USED FOR FIRE SYSTEMS ONLY. METER READS IN CUBIC FEET.
- 9 — THRUST BLOCK PER IRWD STD. DWG. W-16. A D.I. MJ X FL VALVE SETTER MAY BE PROVIDED IN LIEU OF THRUST BLOCK, SUBJECT TO APPROVAL BY DISTRICT.
- 10 — C-900 PVC DR 14 PIPE SECTION, 36" LONG.
- 11 — END CAP, P.O.
- 12 — 4" X 3" D.I. REDUCER F.E. X F.E. FOR 3" DOUBLE CHECK BACKFLOW ASSEMBLY. FOR DEVICES 4" AND GREATER, OMIT REDUCING SPOOLS.

NOTES:

1. NOTIFY IRWD PRIOR TO INSTALLATION OF BACKFLOW DEVICE.
2. FIRE DEPARTMENT CONNECTION AND POST-INDICATOR VALVES SHALL NOT BE PART OF THE BACKFLOW ASSEMBLY AND MUST BE INSTALLED ON THE CUSTOMER SPECIFIED PIPING SIDE.
3. AT NO POINT SHALL ANY PART OF THE BACKFLOW DEVICE BE CLOSER THAN 36" AWAY FROM ANY STRUCTURE, FACE OF CURB, BACK OF SIDEWALK, LANDSCAPING, OR PATH OF TRAVEL.
4. BACKFLOW ASSEMBLY AND IRWD PIPING SHALL BE WITHIN A DEDICATED IRWD EASEMENT OR PUBLIC RIGHT-OF-WAY.
5. PLACE BRASS PLUGS IN ALL 3/4" VALVE OUTLETS.
6. BY-PASS METER TO BE USED FOR FIRE SYSTEMS ONLY. DO NOT INSTALL BY-PASS METERS WHERE SUPPLY TO DEVICE IS ALREADY METERED.
7. SEE IRWD STD. DWG. W-12 FOR TEMPORARY FLUSH-OUT REQUIRED TO CONDUCT HYDROSTATIC TESTING AND CHLORINATION.

DOUBLE CHECK BACKFLOW ASSEMBLY (N-PATTERN), 3" AND LARGER

IRVINE RANCH WATER DISTRICT, ENGINEERING DEPARTMENT

APPROVED BY:

Kevin L. Burton
 KEVIN L. BURTON R.M.E. M28832
 EXECUTIVE DIRECTOR, TECHNICAL SERVICES

FEBRUARY 2025
 REVISION



**IRWD
 STD. DWG.
 W-6**

NOT TO SCALE
 SHEET 2 OF 2

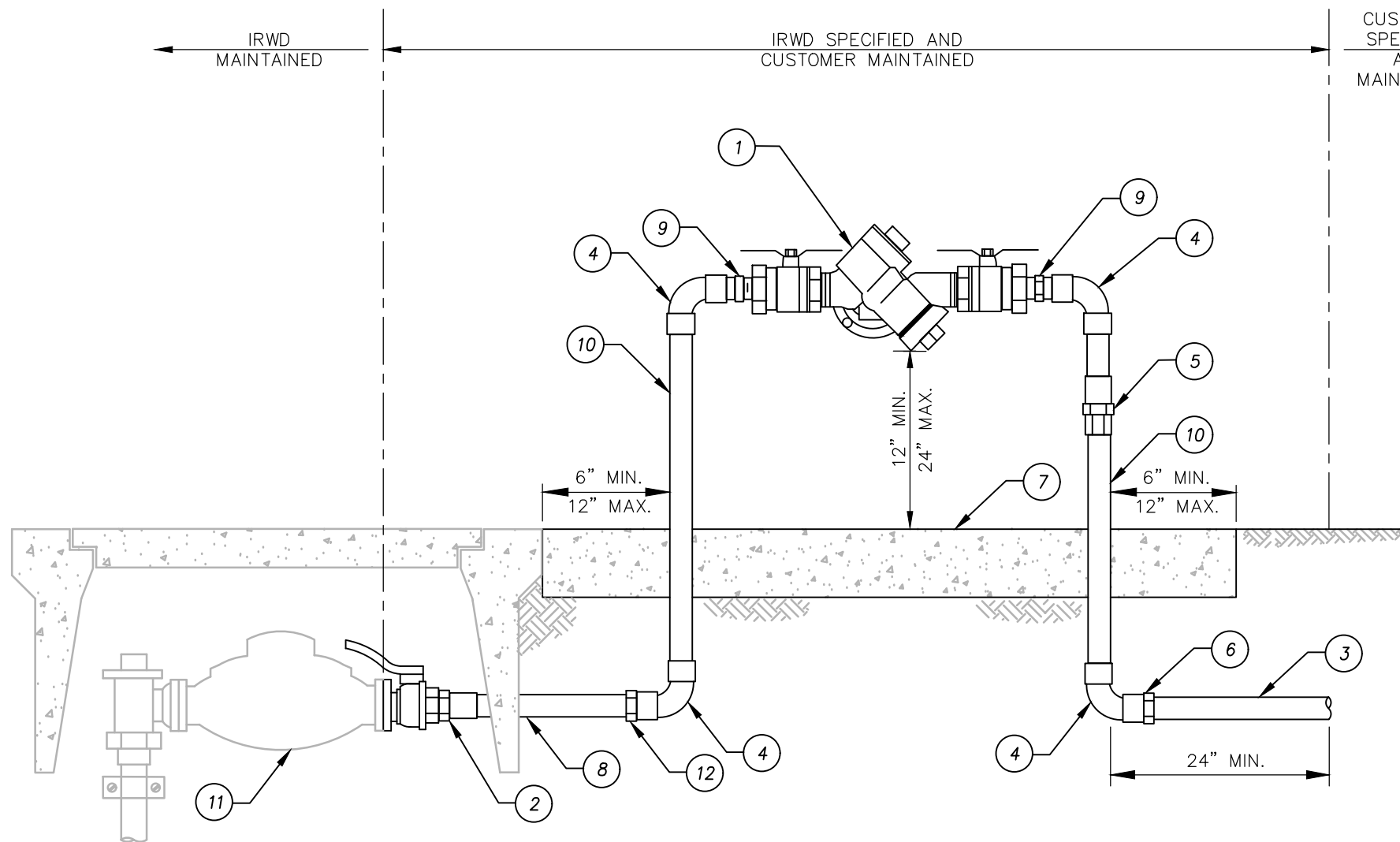

ITEM	MATERIALS
1	3/4" THROUGH 2" REDUCED PRESSURE BACKFLOW PREVENTOR WITH BALL VALVES.
2	PVC ADAPTER, M.I.P.T. X F.I.P.T.
3	COPPER WATER TUBE, TYPE "K" OR BRASS OR SCH 40 PVC.
4	COPPER OR BRASS 90 DEGREE BEND WITH COPPER SOLDER JOINTS.
5	COPPER OR BRASS UNION WITH COPPER SOLDER OR THREADED JOINTS.
6	BRASS OR COPPER TO PVC ADAPTER.
7	18" WIDE X 4" THICK CONCRETE PAD, LENGTH VARIES PER ASSEMBLY SIZE.
8	SCH 40 PVC PIPE.
9	BRASS OR COPPER NIPPLE.
10	COPPER WATER TUBE, TYPE "K" OR BRASS.
11	1" OR 2" SERVICE PER IRWD STD. DWG. W-1 AND W-2.
12	PVC TO BRASS OR COPPER ADAPTER.

NOTES:

1. PROVIDE AN USC APPROVED BACKFLOW PREVENTION ASSEMBLY.
2. IRWD MAINTENANCE RESPONSIBILITY STOPS AT THE METER. THE CUSTOMER IS RESPONSIBLE TO TEST AND MAINTAIN THE BACKFLOW PREVENTION ASSEMBLY. CERTIFICATION SHALL BE DELIVERED TO IRWD.
3. BACKFLOW CERTIFICATION TESTING IS REQUIRED ANNUALLY AT A MINIMUM BUT MAY BE MORE FREQUENT AS DEEMED NECESSARY BY IRWD. CERTIFICATION TESTING IS REQUIRED IMMEDIATELY AFTER AN ASSEMBLY IS RELOCATED, REPLACED, AND REPAIRED.
4. BACKFLOW PREVENTION ASSEMBLY SIZE SHALL MATCH THE DIAMETER OF THE METER IN ACCORDANCE WITH THE UNIFORM PLUMBING CODE; CHAPTER 6, SECTION 610 AS AMENDED, OR UP TO 1" LARGER.
5. BACKFLOW PREVENTION ASSEMBLY INSTALLATIONS INCLUDING ALL APPURTENANCES FOR THE SUPPLY OF DOMESTIC WATER SHALL COMPLY WITH THE REQUIREMENTS OF THE CALIFORNIA LEAD-FREE ACT AB1953.
6. BACKFLOW PREVENTION ASSEMBLY SHALL BE LOCATED AS CLOSE AS PRACTICAL TO THE WATER METER BOX BUT NOT FURTHER THAN 12".
7. NO OUTLETS, TEES, OR CONNECTIONS SHALL BE ALLOWED BETWEEN THE METER AND THE BACKFLOW PREVENTION ASSEMBLY.
8. BACKFLOW PREVENTION ASSEMBLIES SHALL MAINTAIN A VERTICAL CLEARANCE FROM THE LOWEST POINT OF 12" (MIN.) TO 24" (MAX.) ABOVE FINISHED GRADE, WITH SIDE AND TOP CLEARANCES OF 12" (MIN.) FOR ANY OBSTRUCTIONS IN ALL DIRECTIONS.
9. PARALLEL INSTALLATIONS OF THE SAME TYPE OF BACKFLOW PREVENTION ASSEMBLIES ARE RECOMMENDED FOR ALL FACILITIES REQUIRING UNINTERRUPTED WATER SUPPLY, SUCH AS, HOSPITALS AND SCHOOLS.
10. THEFT PREVENTION DEVICES ARE RECOMMENDED FOR BRASS ASSEMBLIES ALLOWING ADEQUATE ACCESS TO THE ASSEMBLY FOR TESTING, MAINTENANCE, AND PROPER DRAINAGE.

REDUCED PRESSURE PRINCIPLE BACKFLOW ASSEMBLY, 2" AND SMALLER

IRVINE RANCH WATER DISTRICT, ENGINEERING DEPARTMENT

APPROVED BY:

KEVIN L. BURTON R.M.E. M28832
EXECUTIVE DIRECTOR, TECHNICAL SERVICES

FEBRUARY 2025
REVISION



Irvine Ranch
WATER DISTRICT

IRWD
STD. DWG.
W-7

NOT TO SCALE
SHEET 1 OF 3

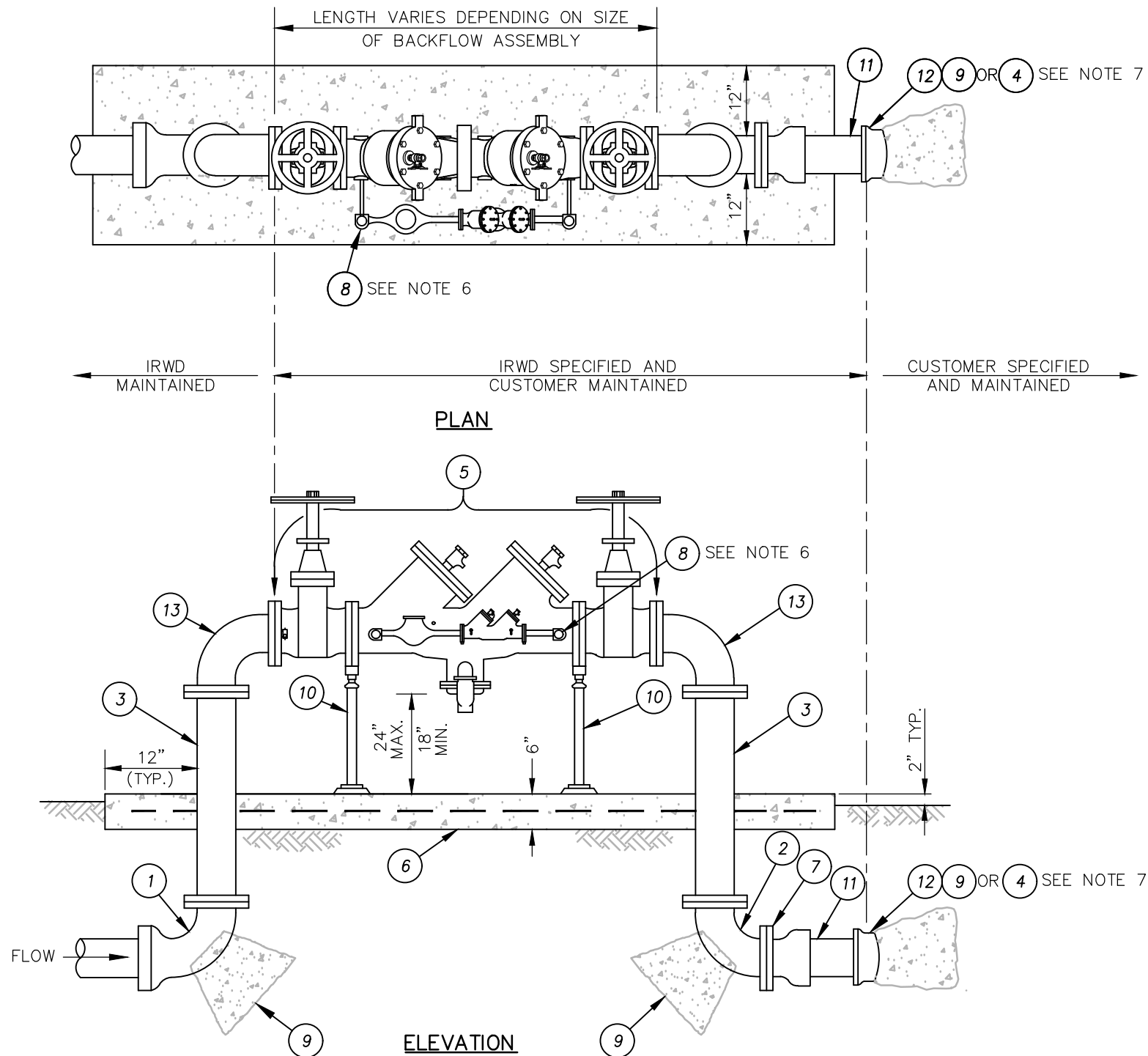

- | ITEM | MATERIALS |
|------|--|
| 1 | D.I. 90° BEND, F.E. X P.O. |
| 2 | D.I. 90° BEND, F.E. X F.E. |
| 3 | D.I. SPOOL, F.E. X F.E., LENGTH AS REQUIRED. |
| 4 | TRANSITION COUPLING (BY OTHERS, FOR ON-SITE CONNECTION WHEN ON-SITE PIPING EXISTS). |
| 5 | APPROVED REDUCED PRESSURE PRINCIPAL BACKFLOW PREVENTION ASSEMBLY WITH RISING STEM RESILIENT WEDGE GATE VALVES, VALVES SHALL BE PROVIDED AS AN INTEGRAL PART OF BACKFLOW ASSEMBLY. |
| 6 | 6" THICK P.C.C. SLAB, REINFORCE WITH W.W.F. 1.6 X 1.6. |
| 7 | F.E. X P.O. ADAPTER. |
| 8 | FACTORY INSTALLED BY-PASS METER ASSEMBLY CONSISTING OF APPROVED POSITIVE DISPLACEMENT METER, REDUCED PRESSURE PRINCIPAL DEVICE AND ASSOCIATED PIPING PER IRWD STD. SPEC. SECTION 15112. METER TO BE USED FOR FIRE SYSTEMS ONLY. METER READS IN CUBIC FEET. |
| 9 | THRUST BLOCK PER IRWD STD. DWG. W-16. |
| 10 | ADJUSTABLE PIPE SUPPORT FOR ASSEMBLIES 8" DIA. AND LARGER PER IRWD STD. DWG. W-24. |
| 11 | C-900 PVC DR 14 PIPE SECTION, 36" LONG. |
| 12 | END CAP, P.O. |
| 13 | D.I. 90° BEND, F.E. X F.E. FOR 3" REDUCED PRESSURE PRINCIPLE BACKFLOW ASSEMBLY USE 4" X 3" D.I. 90° REDUCING BEND, F.E. X F.E. |

NOTES:

1. NOTIFY IRWD PRIOR TO INSTALLATION OF BACKFLOW DEVICE.
2. FIRE DEPARTMENT CONNECTION AND POST-INDICATOR VALVES SHALL NOT BE PART OF THE BACKFLOW ASSEMBLY AND MUST BE INSTALLED ON THE CUSTOMER SPECIFIED PIPING SIDE.
3. AT NO POINT SHALL ANY PART OF THE BACKFLOW DEVICE BE CLOSER THAN 36" AWAY FROM ANY STRUCTURE, FACE OF CURB, BACK OF SIDEWALK, LANDSCAPING, OR PATH OF TRAVEL.
4. BACKFLOW ASSEMBLY AND IRWD PIPING SHALL BE WITHIN A DEDICATED IRWD EASEMENT OR PUBLIC RIGHT OF WAY.
5. PLACE BRASS PLUGS IN ALL 3/4" VALVE OUTLETS.
6. BY-PASS METER TO BE USED FOR FIRE SYSTEMS ONLY. DO NOT INSTALL BY-PASS METERS WHERE SUPPLY TO DEVICE IS ALREADY METERED.
7. SEE IRWD STD. DWG. W-12 FOR TEMPORARY FLUSH-OUT REQUIRED TO CONDUCT HYDROSTATIC TESTING AND CHLORINATION.

REDUCED PRESSURE PRINCIPLE BACKFLOW ASSEMBLY, 3" AND LARGER

IRVINE RANCH WATER DISTRICT, ENGINEERING DEPARTMENT

APPROVED BY:

Kevin L. Burton

KEVIN L. BURTON R.M.E. M28832
EXECUTIVE DIRECTOR, TECHNICAL SERVICES

FEBRUARY 2025
REVISION



IRWD
STD. DWG.
W-7

NOT TO SCALE
SHEET 2 OF 3

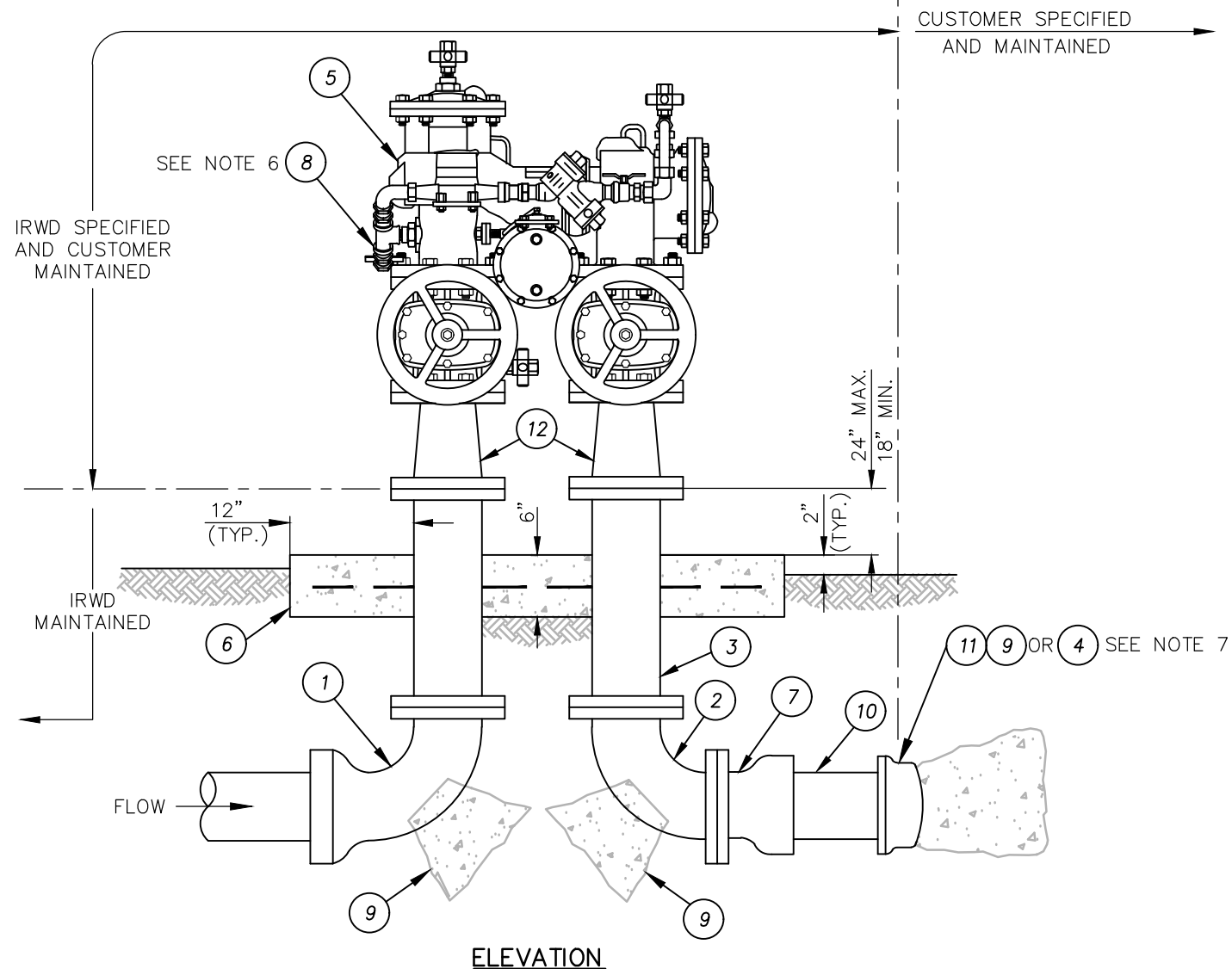
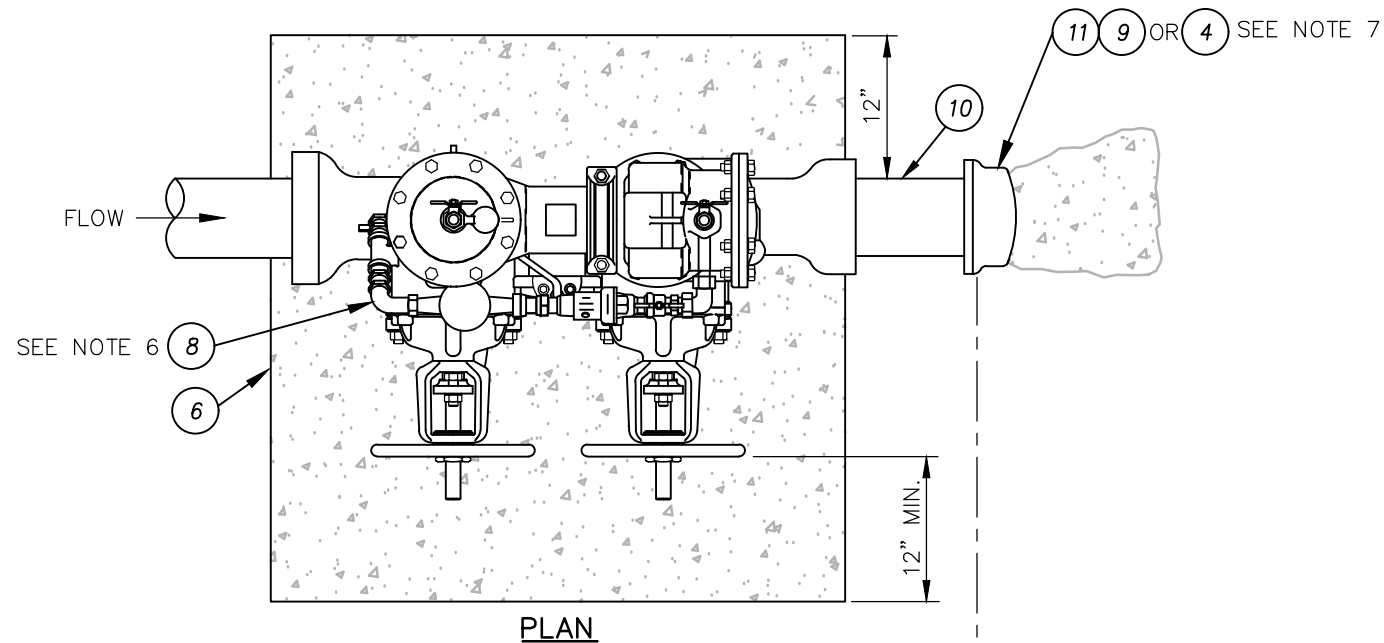

ITEM MATERIALS

- 1 — D.I. 90° BEND, F.E. X P.O.
- 2 — D.I. 90° BEND, F.E. X F.E.
- 3 — D.I. SPOOL, F.E. X F.E., LENGTH AS REQUIRED.
- 4 — TRANSITION COUPLER (BY OTHERS, FOR ON-SITE CONNECTION WHEN ON-SITE PIPING EXISTS).
- 5 — APPROVED N-PATTERN REDUCED PRESSURE PRINCIPAL BACKFLOW PREVENTION ASSEMBLY WITH RISING STEM RESILIENT WEDGE GATE VALVES, VALVES SHALL BE PROVIDED AS AN INTEGRAL PART OF BACKFLOW ASSEMBLY.
- 6 — 6" THICK P.C.C. SLAB, REINFORCE WITH W.W.F. 1.6 X 1.6.
- 7 — F.E. X P.O. ADAPTER.
- 8 — FACTORY INSTALLED BY-PASS METER ASSEMBLY CONSISTING OF APPROVED POSITIVE DISPLACEMENT METER, REDUCED PRESSURE PRINCIPAL DEVICE AND ASSOCIATED PIPING PER IRWD STD. SPEC. SECTION 15112. METER TO BE USED FOR FIRE SYSTEMS ONLY. METER READS IN CUBIC FEET.
- 9 — THRUST BLOCK PER IRWD STD. DWG. W-16. A D.I. MJ X FL VALVE SETTER MAY BE PROVIDED IN LIEU OF THRUST BLOCK, SUBJECT TO APPROVAL BY DISTRICT.
- 10 — C-900 PVC DR 14 PIPE SECTION, 36" LONG.
- 11 — END CAP, P.O.
- 12 — 4" X 3" D.I. REDUCER, F.E. X F.E., FOR 3" DOUBLE CHECK BACKFLOW ASSEMBLY.

NOTES:

1. NOTIFY IRWD PRIOR TO INSTALLATION OF BACKFLOW DEVICE.
2. FIRE DEPARTMENT CONNECTION AND POST-INDICATOR VALVES SHALL NOT BE PART OF THE BACKFLOW ASSEMBLY AND MUST BE INSTALLED ON THE CUSTOMER SPECIFIED PIPING SIDE.
3. AT NO POINT SHALL ANY PART OF THE BACKFLOW DEVICE BE CLOSER THAN 36" AWAY FROM ANY STRUCTURE, FACE OF CURB, BACK OF SIDEWALK, LANDSCAPING, OR PATH OF TRAVEL.
4. BACKFLOW ASSEMBLY AND IRWD PIPING SHALL BE WITHIN A DEDICATED IRWD EASEMENT OR PUBLIC RIGHT OF WAY.
5. PLACE BRASS PLUGS IN ALL 3/4" VALVE OUTLETS.
6. BY-PASS METER TO BE USED FOR FIRE SYSTEMS ONLY. DO NOT INSTALL BY-PASS METERS WHERE SUPPLY TO DEVICE IS ALREADY METERED.
7. SEE IRWD STD. DWG. W-12 FOR TEMPORARY FLUSH-OUT REQUIRED TO CONDUCT HYDROSTATIC TESTING AND CHLORINATION.

REDUCED PRESSURE PRINCIPLE BACKFLOW ASSEMBLY (N-PATTERN), 3' AND LARGER

IRVINE RANCH WATER DISTRICT, ENGINEERING DEPARTMENT

APPROVED BY:

Kevin L. Burton
 KEVIN L. BURTON R.M.E. M28832
 EXECUTIVE DIRECTOR, TECHNICAL SERVICES

FEBRUARY 2025
 REVISION



IRWD
 STD. DWG.
 W-7

NOT TO SCALE
 SHEET 3 OF 3

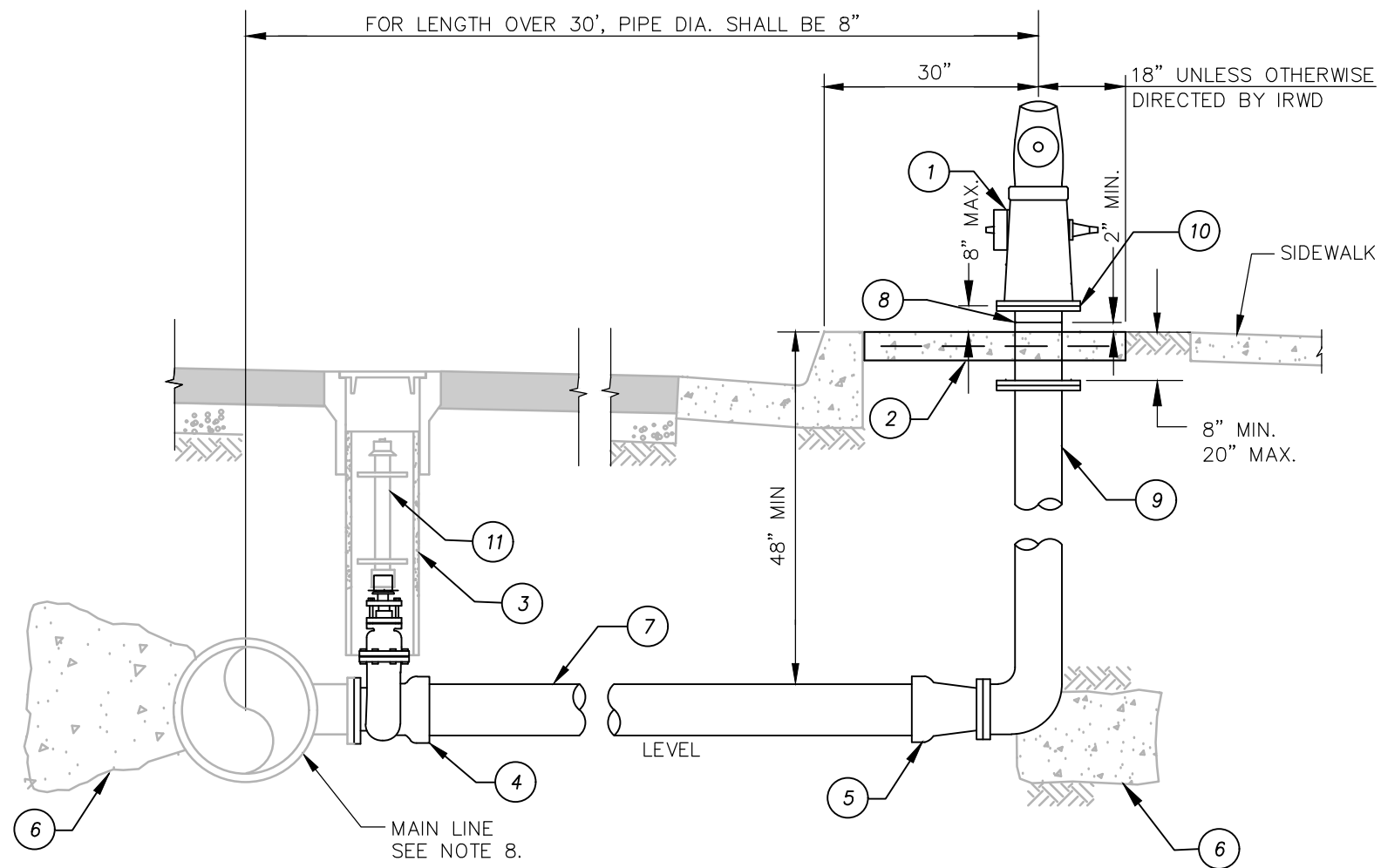

- | ITEM | MATERIALS |
|------|--|
| 1 | RESIDENTIAL HYDRANT WITH (1) 4" AND (1) 2-1/2" FIRE HOSE OUTLETS. NON-RESIDENTIAL HYDRANT WITH (2) 4" AND (1) 2-1/2" FIRE HOSE OUTLETS. |
| 2 | CONSTRUCT 48" X 36" X 6" THICK OR 36" X 36" X 6" THICK CONCRETE PAD REINFORCED WITH W.W.F. 1.6 X 1.6, SEE HYDRANT LOCATION PLANS BELOW FOR APPLICABLE CONDITION. |
| 3 | VALVE BOX PER IRWD STD. DWG. W-22. |
| 4 | 6" OR 8" F.E. X P.O. VALVE. |
| 5 | 8" X 6" REDUCER ON LONG SIDE OF STREET, P.O. X F.E. WITH FLANGE BURY (WHERE REQUIRED). |
| 6 | THRUST BLOCK PER IRWD STD. DWG. W-16. |
| 7 | C-900 PVC PIPE OR DIP WHERE REQUIRED. |
| 8 | HYDRANT SPOOL. MIN. LENGTH = 12", MAX. LENGTH = 24". ONE SCORE PER SPOOL ABOVE CONCRETE PAD AS SHOWN. |
| 9 | FIRE HYDRANT BURY (42" TYP.). |
| 10 | ZINC-PLATED BREAK-AWAY BOLTS AT HYDRANT FLANGE. |
| 11 | VALVE STEM EXTENSION PER IRWD STD. DWG. W-23 (WHERE REQUIRED). |
| 12 | HYDRANT CHECK VALVE PER IRWD STD. SPEC. SECTION 15139 TO BE INSTALLED ONLY WHERE CALLED FOR ON PLANS. |

NOTES:

- SEE IRWD STD. SPEC. SECTION 15139 FOR APPROVED HYDRANT TYPES AND ADDITIONAL REQUIREMENTS.
- HYDRANTS SHALL BE PAINTED ACCORDING TO PAINT SCHEDULE PER IRWD STD. SPEC. SECTION 09900.
- HYDRANT FLANGE GASKET SHALL BE "FULL FACE" AND OF RUBBER COMPOSITION 1/8" THICK.
- SCORED SPOOL MAY BE UTILIZED TO ADJUST HYDRANT TO GRADE.
- LOCATE 4" OUTLET PERPENDICULAR TO THE CURB LINE.
- FILL ZINC-PLATED BREAK-AWAY BOLTS WITH SILICONE SEALANT.
- COMMERCIAL PROPERTY FIRE HYDRANTS: ORIENTATION OF OUTLETS TO BE DETERMINED BY DISTRICT REPRESENTATIVE.
- MAIN LINE TEE SHALL BE FLANGED.
- AT NO POINT SHALL ANY PART OF THE FIRE HYDRANT BE CLOSER THAN 36" AWAY FROM ANY STRUCTURE, LANDSCAPING OR PATH OF TRAVEL.

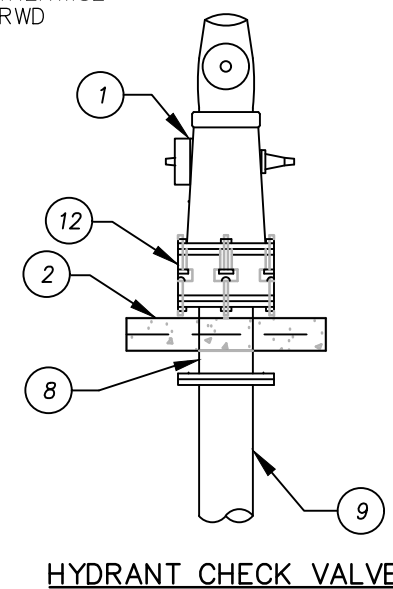
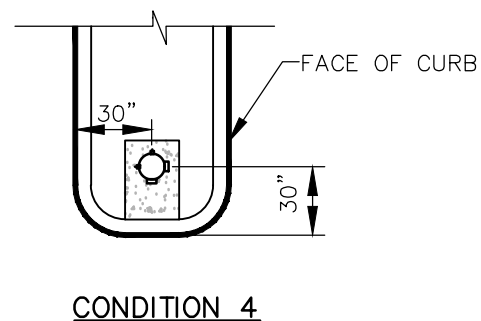
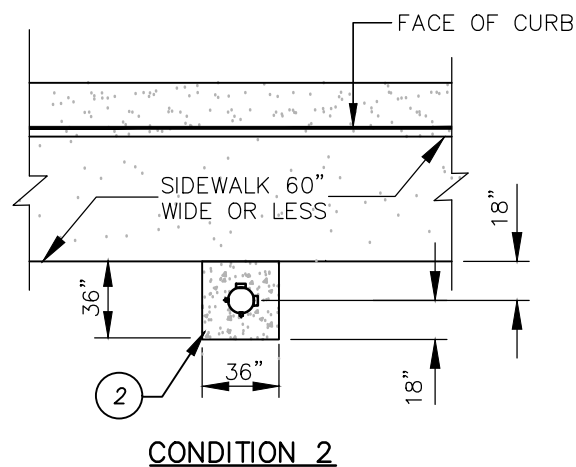
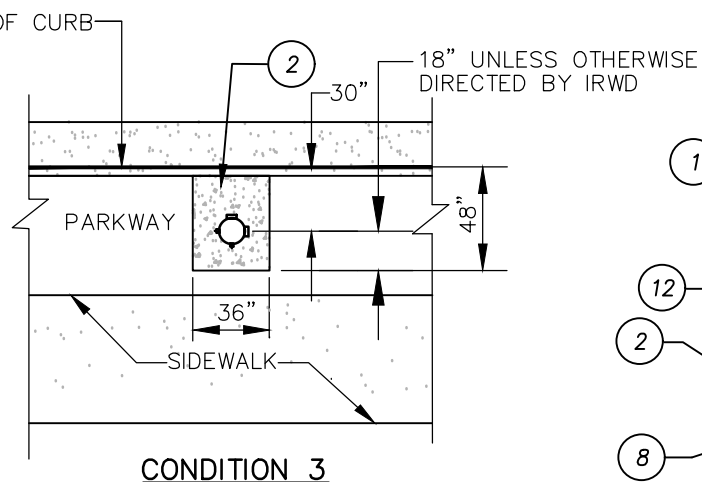
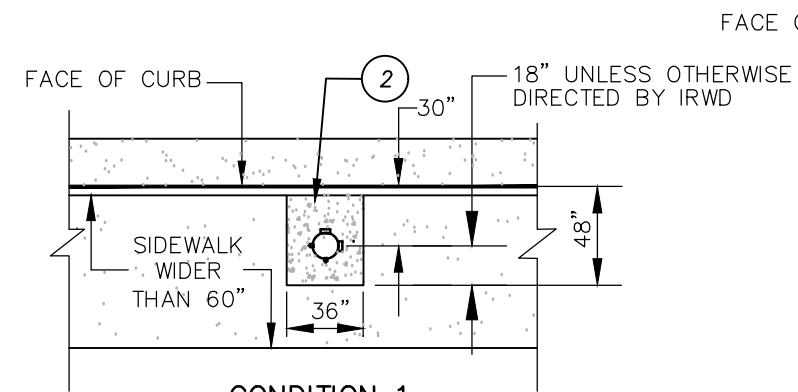

HYDRANT LOCATION PLANS

FIRE HYDRANT

IRVINE RANCH WATER DISTRICT, ENGINEERING DEPARTMENT
 APPROVED BY:
Kevin L. Burton
 KEVIN L. BURTON R.M.E. M28832
 EXECUTIVE DIRECTOR, TECHNICAL SERVICES

FEBRUARY 2025
 REVISION



IRWD
 STD. DWG.
 W-8
 NOT TO SCALE
 SHEET 1 OF 1

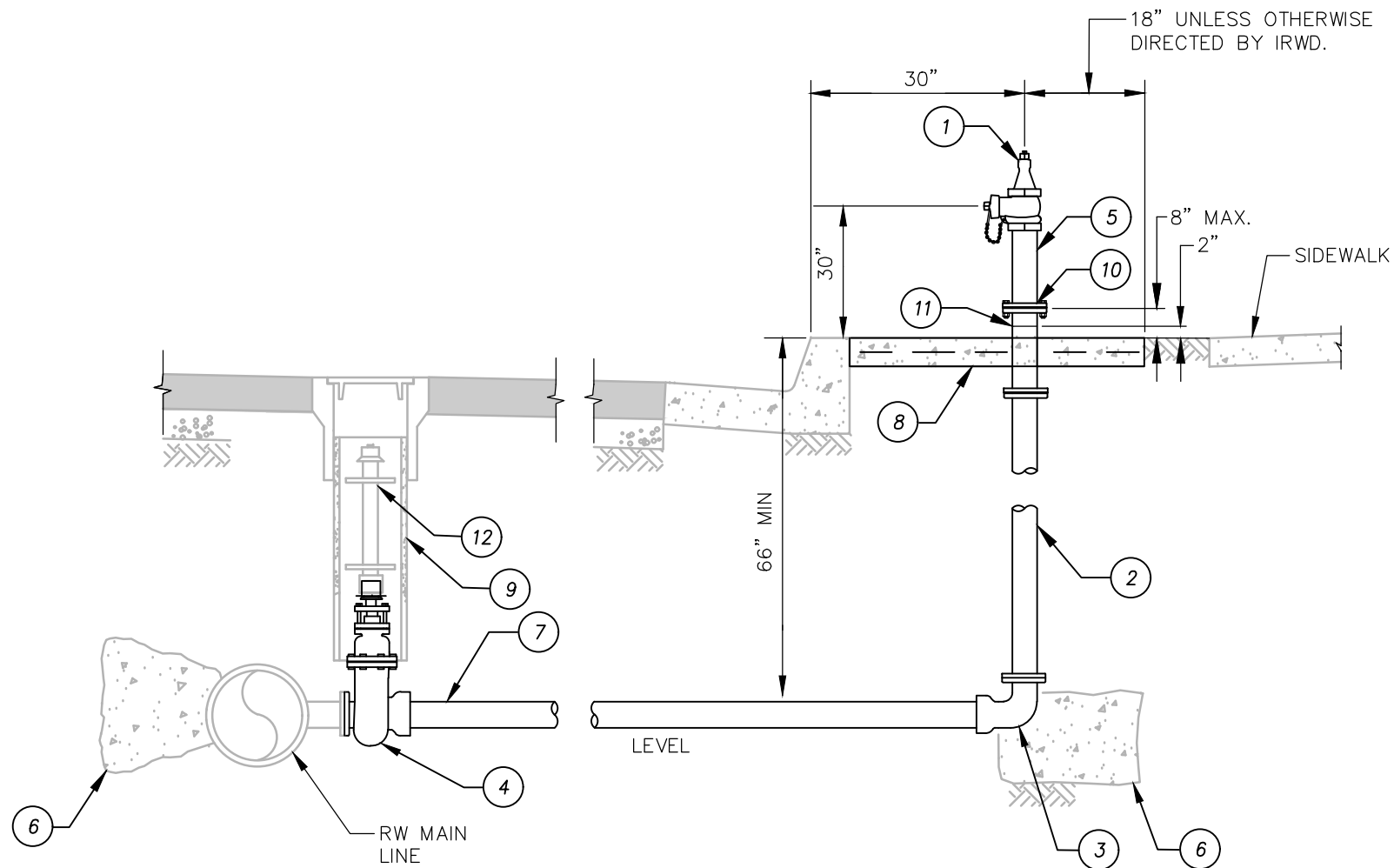

ITEM	MATERIALS
1	RECYCLED WATER WHARF HEAD STYLE HYDRANT WITH 2-1/2" HOSE OUTLET.
2	4" D.I.P. SPOOL, F.E. X F.E.
3	4" D.I.P., 90 DEGREE BEND, P.O. X F.E.
4	4" F.E. X P.O. VALVE.
5	4" BRASS NIPPLE, M.I.P.T X M.I.P.T.
6	THRUST BLOCK PER IRWD STD. DWG. W-16.
7	4" C-900 PVC PIPE OR DIP WHERE REQUIRED.
8	CONSTRUCT 48" X 36" X 6" THICK OR 36" X 36" X 6" THICK CONCRETE PAD REINFORCED WITH W.W.F. 1.6 X 1.6, SEE HYDRANT LOCATION PLANS BELOW FOR APPLICABLE CONDITION.
9	VALVE BOX PER IRWD STD. DWG. W-22.
10	4" BRONZE COMPANION FLANGES, THREADED, WITH ZINC-PLATED BREAK-AWAY BOLTS.
11	4" SCORED SPOOL, F.E. X F.E. (SCORED END 2" ABOVE PAD). MIN. LENGTH = 12". MAX. LENGTH = 24". ONE SCORE PER SPOOL.
12	VALVE STEM EXTENSION PER IRWD STD. DWG. W-23 (WHERE REQUIRED).

NOTES:

- SEE IRWD STD. SPEC. SECTION 15139 FOR APPROVED HYDRANT TYPES AND ADDITIONAL REQUIREMENTS.
- RECYCLED WATER WHARF HEAD TYPE HYDRANTS MAY BE USED TEMPORARILY AND SHALL BE LOCATED OFF BLOW-OFFS OR MAIN LINES ONLY. AFTER TEMPORARY USE HAS CONCLUDED, BLOW-OFFS OR MAIN LINES SHALL BE RESTORED BACK TO THEIR PERMANENT CONDITION PER THE DIRECTION OF IRWD.
- RECYCLED WATER WHARF HEAD TYPE HYDRANTS FOR PERMANENT USE SHALL BE CONSTRUCTED ON THE MAIN LINE ONLY IN SELECT LOCATIONS AS APPROVED BY IRWD.
- RECYCLED WATER WHARF HEAD TYPE HYDRANTS SHALL BE PAINTED ACCORDING TO PAINT SCHEDULE PER IRWD STD. SPEC. SECTION 09900.
- LOCATE 2-1/2" HOSE OUTLET PERPENDICULAR TO THE CURB LINE.
- AT NO POINT SHALL ANY PART OF THE HYDRANT BE CLOSER THAN 36" AWAY FROM ANY STRUCTURE, LANDSCAPING OR PATH OF TRAVEL.
- FILL ZINC-PLATED BREAK-AWAY BOLTS WITH SILICONE SEALANT.

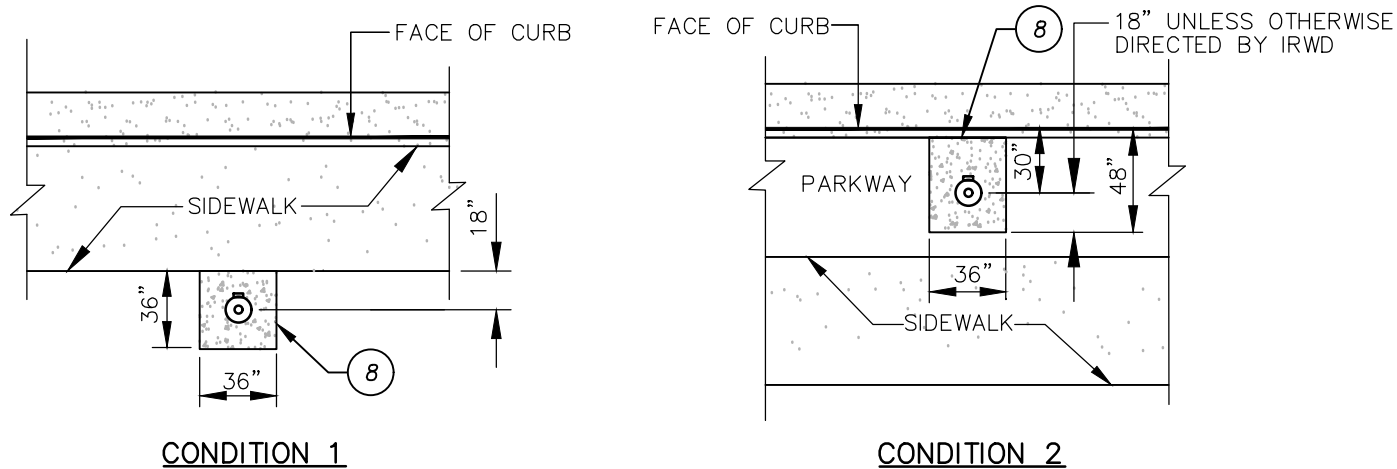

HYDRANT LOCATION PLANS

RECYCLED WATER WHARF HEAD HYDRANT

IRVINE RANCH WATER DISTRICT, ENGINEERING DEPARTMENT

APPROVED BY:

Kevin L. Burton
 KEVIN L. BURTON R.M.E. M28832
 EXECUTIVE DIRECTOR, TECHNICAL SERVICES

FEBRUARY 2025
 REVISION



**IRWD
 STD. DWG.
 W-9**
 NOT TO SCALE
 SHEET 1 OF 1

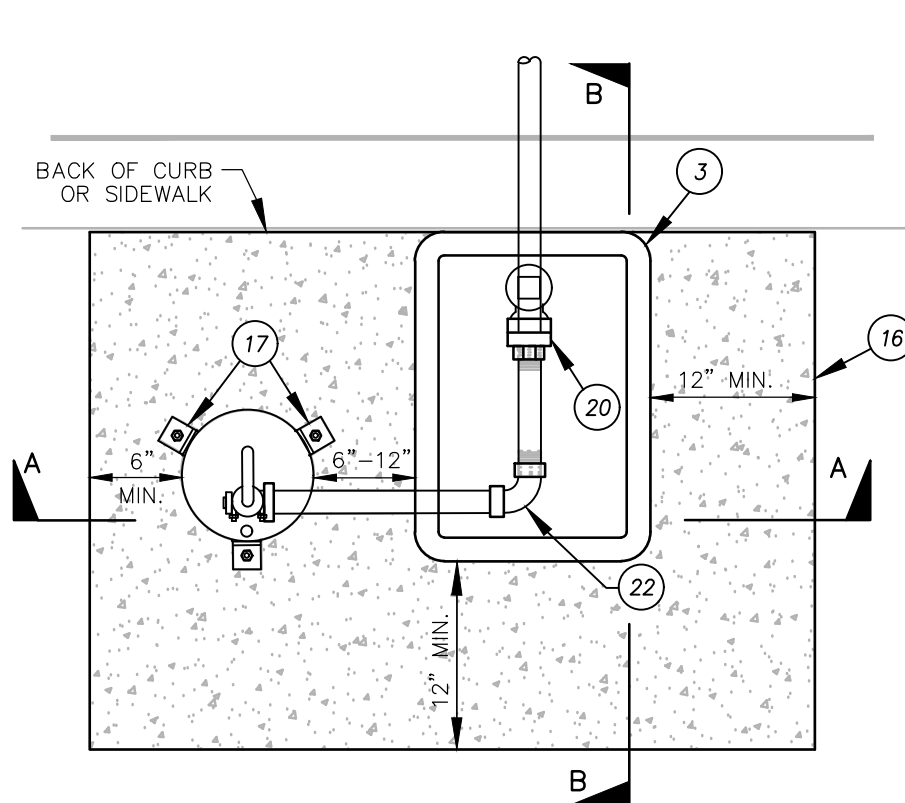

PLAN

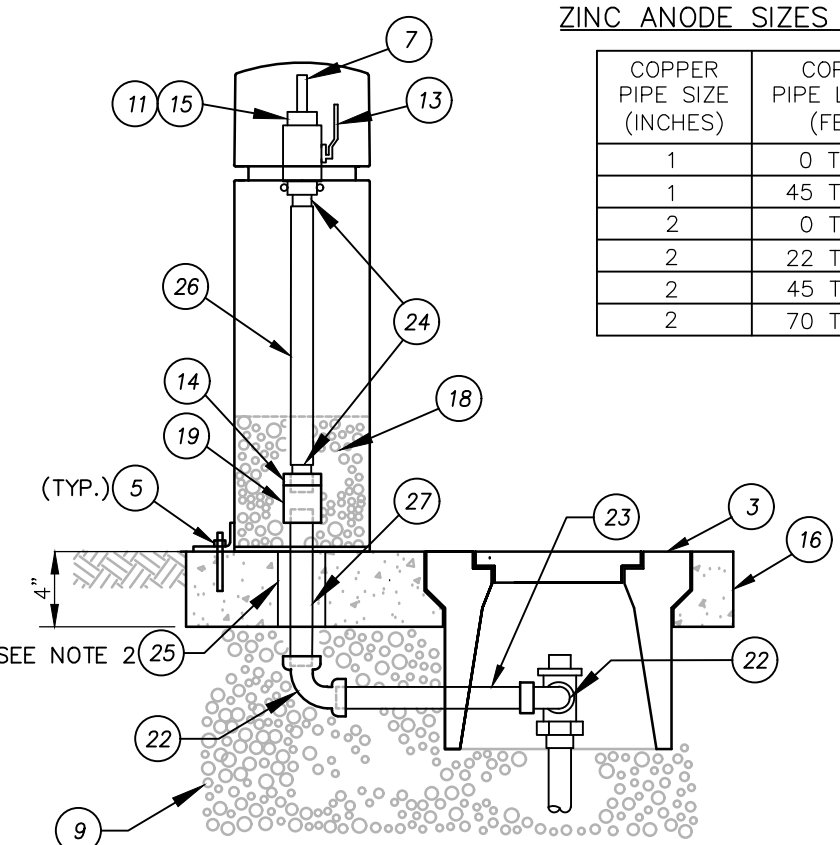
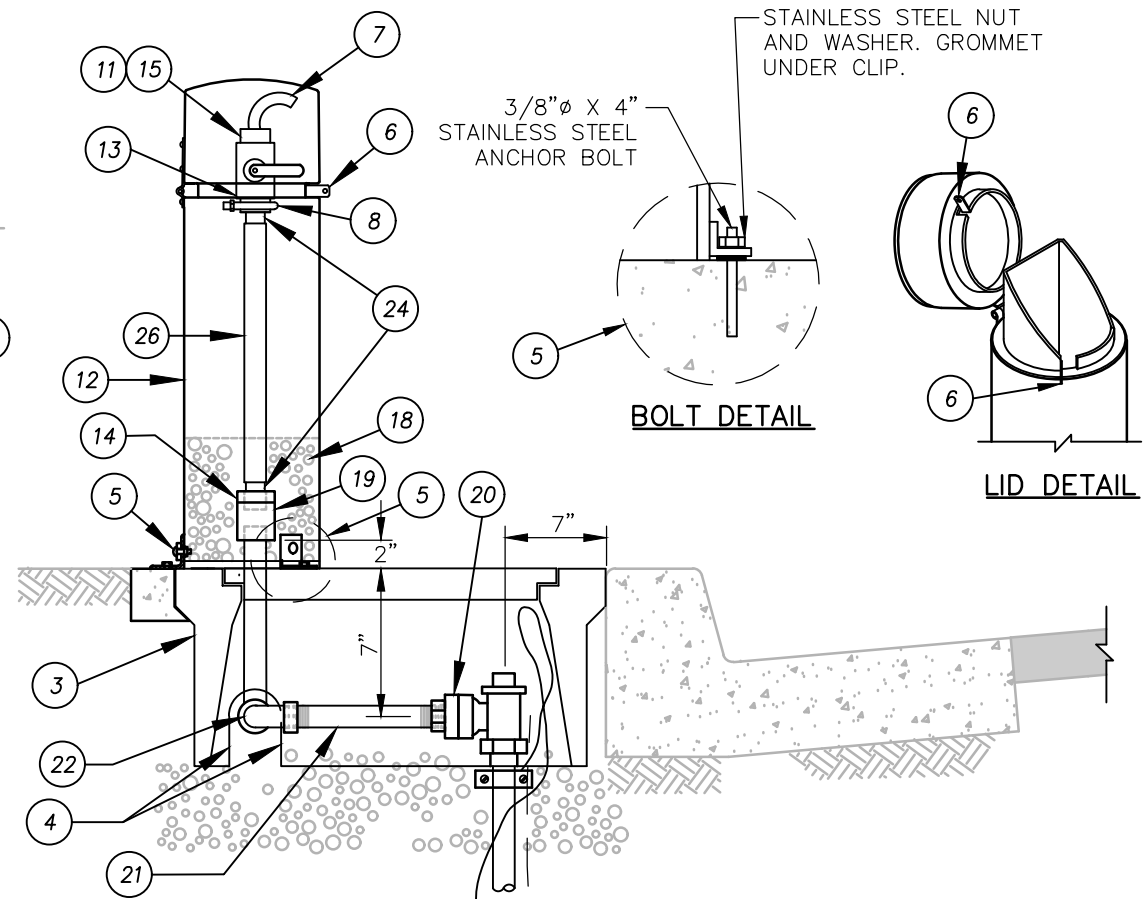

SECTION A-A

ZINC ANODE SIZES FOR 1" AND 2" COPPER SERVICES

COPPER PIPE SIZE (INCHES)	COPPER PIPE LENGTH (FEET)	ZINC ANODE SIZE (INCHES)	ZINC ANODE WEIGHT (LBS)
1	0 TO 45	1.4 X 1.4 X 30	15
1	45 TO 90	2.0 X 2.0 X 30	30
2	0 TO 22	1.4 X 1.4 X 30	15
2	22 TO 45	2.0 X 2.0 X 30	30
2	45 TO 70	2.0 X 2.0 X 48	40
2	70 TO 90	2.0 X 2.0 X 60	60

NOTES:

1. ALL HARDWARE SHALL BE TYPE 316 STAINLESS STEEL.
2. FILL ANNULAR SPACE IN SLAB SLEEVE WITH SAND.
3. INSTALL IRWD LOGO DECAL "DOMESTIC" OR "RECYCLED" AS DIRECTED BY IRWD.
4. COVERS SHALL BE MANUFACTURED BY ARMORCAST PRODUCTS OR PIPELINE PRODUCTS, INC. SEE IRWD STD. SPEC. SECTION 15089 FOR SIMILAR APPLICATION.
5. AT NO POINT SHALL ANY PART OF THE WATER SAMPLE STATION BE CLOSER THAN 36" AWAY FROM ANY STRUCTURE, LANDSCAPING OR PATH OF TRAVEL.

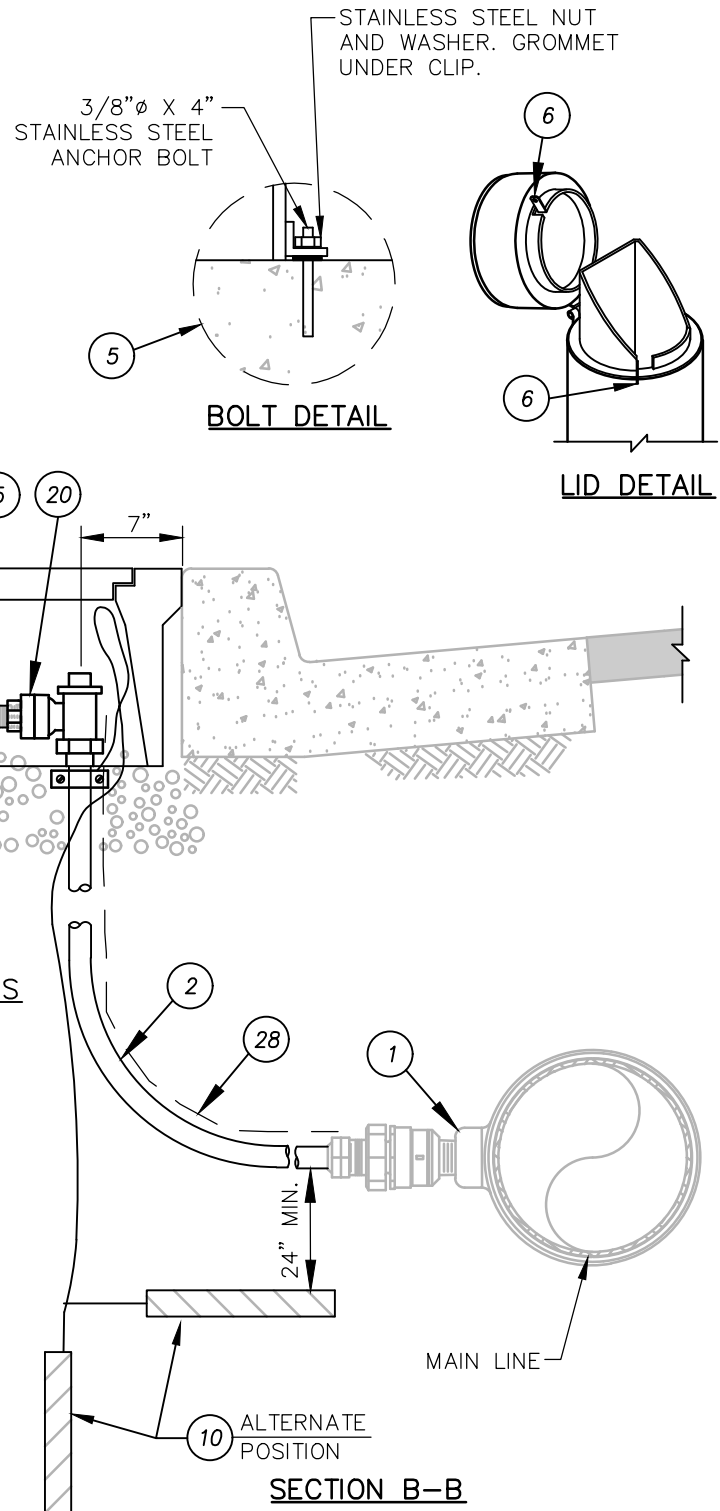

SECTION B-B

- | ITEM | MATERIALS |
|------|---|
| 1 | 1" SERVICE CONNECTION PER IRWD STD. DWG. W-1. |
| 2 | 1" TYPE "K" SOFT COPPER TUBING PER IRWD STD. DWG. W-1. |
| 3 | POLYMER CONCRETE METER BOX WITH READING LID PER IRWD STD. DWG. W-1. |
| 4 | SAWCUT OR CORE DRILL FOR 1" PIPE. |
| 5 | 3/8" DIA. X 4" LONG TYPE 316 STAINLESS STEEL ANCHOR BOLT (3 EACH AT 120° APART WITH 2-PART EPOXY AND STAINLESS STEEL NUTS AND WASHERS). INSTALL WITH RUBBER GROMMET UNDER ANCHOR CLIPS TO PROVIDE 1/4" GAP. |
| 6 | LOCK HASP FOR #5 LOCK, SEE LID DETAIL HEREON. |
| 7 | 3/8" TYPE "K" SOFT COPPER SPIGOT BEND TO 120° FOR DOWNWARD OPENING W/CAP. |
| 8 | 5/16" DIA. U-BOLT ASSEMBLY SIZED FOR 1" DIA. PIPE, STAINLESS STEEL. |
| 9 | 3/4" CRUSHED ROCK, PLACE TO DEPTH 6" BELOW CONCRETE METER BOX. |
| 10 | ZINC ANODE (SEE TABLE HEREON FOR SIZE OF ANODE) AND LEAD WIRE. ANODE TO BE PLACED VERTICALLY OR HORIZONTALLY AT A MIN. SEPARATION OF 24" FROM THE COPPER PIPE. |
| 11 | 1/2" X 3/8" COPPER TUBE FLARE NUT X M.I.P.T. ADAPTER. |
| 12 | LINEAR LOW DENSITY POLYETHYLENE SAMPLE STATION COVER. 12" DIA. X 30" HIGH. SEE NOTES 3 AND 4. |
| 13 | 1/2" STAINLESS STEEL TEFLON SEATED BALL VALVE, F.I.P.T. X F.I.P.T. (ORIENT VALVE HANDLE TOWARD FRONT OF SAMPLE STATION). |
| 14 | 1" X 1/2" BRASS BUSHING, M.I.P.T. X F.I.P.T. |
| 15 | 1/2" M.I.P.T. X FEMALE FLARE FITTING. |
| 16 | 4" THICK CLASS "B" CONCRETE. |
| 17 | 3 ANCHOR CLIPS WITH 1/2" HOLES AT 120° SPACING. |
| 18 | 3/4" GRAVEL, 12" DEEP IN BOTTOM OF CAN. |
| 19 | 1" PVC SCH 80 COUPLING, F.I.P.T. X F.I.P.T. |
| 20 | 1" METER NUT BY F.I.P.T. ADAPTER. |
| 21 | 1" RED BRASS NIPPLE, T.B.E., 6" LONG. |
| 22 | 1" BRASS 90° BEND, F.I.P.T. X F.I.P.T. |
| 23 | 1" RED BRASS NIPPLE, T.B.E. |
| 24 | 1/2" SWEAT X M.I.P.T. ADAPTER. |
| 25 | 2" SCH 80 PVC SLEEVE. |
| 26 | 1/2" TYPE "K" RIGID COPPER PIPE. |
| 27 | 1" RED BRASS NIPPLE, T.B.E., 10" LONG. |
| 28 | IDENTIFICATION TAPE PER IRWD STD. SPEC. SECTION 15151. TAPE TO COPPER PIPE AT 2' INTERVALS USING 2" WIDE 10-MIL TAPE. |

WATER SAMPLE STATION

IRVINE RANCH WATER DISTRICT, ENGINEERING DEPARTMENT
 APPROVED BY:

 KEVIN L. BURTON R.M.E. M28832
 EXECUTIVE DIRECTOR, TECHNICAL SERVICES

FEBRUARY 2025
 REVISION

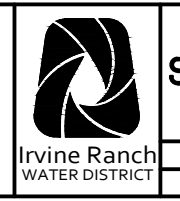

IRWD
 STD. DWG.
 W-10
 NOT TO SCALE
 SHEET 1 OF 1

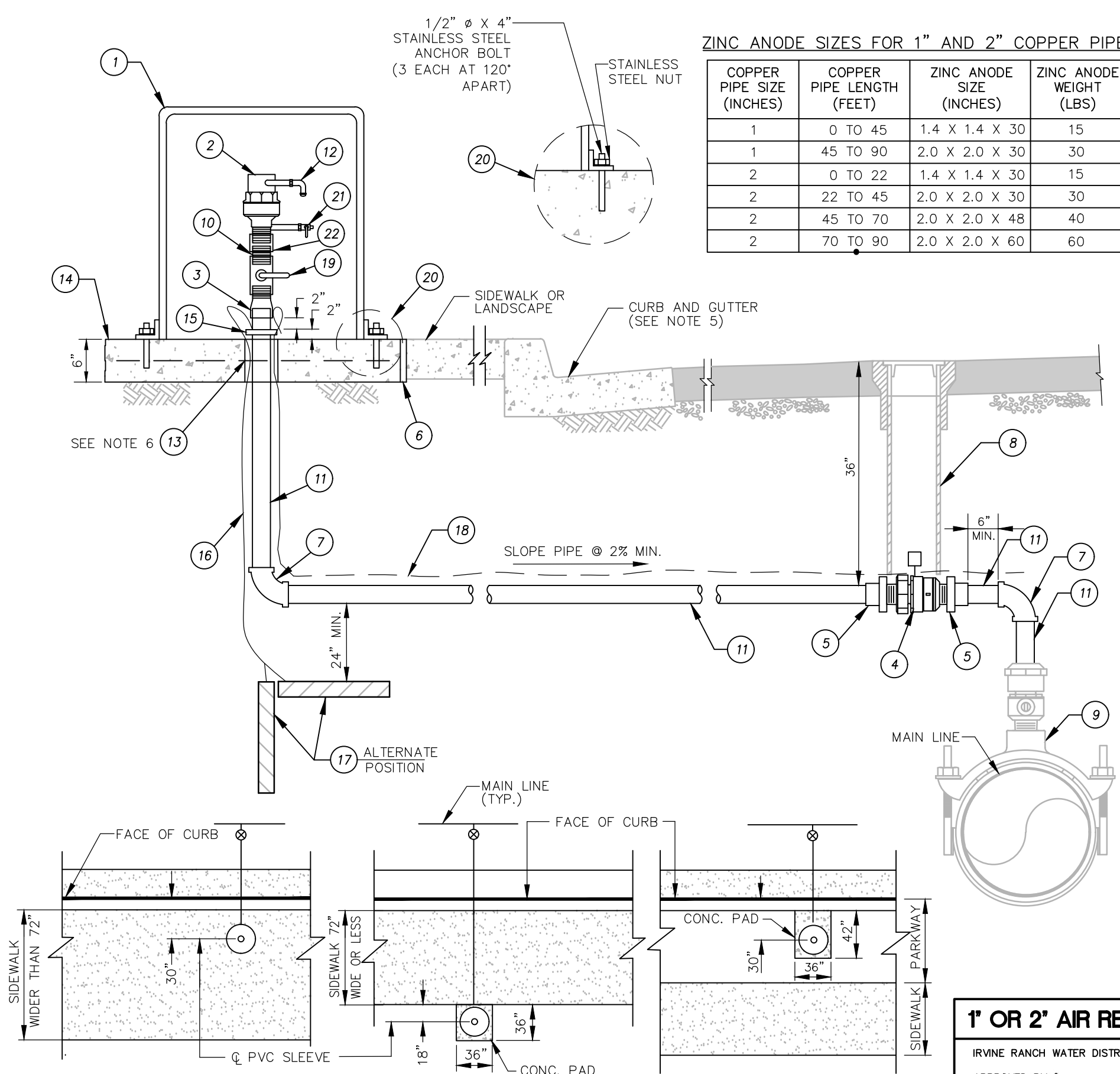



ZINC ANODE SIZES FOR 1" AND 2" COPPER PIPE

COPPER PIPE SIZE (INCHES)	COPPER PIPE LENGTH (FEET)	ZINC ANODE SIZE (INCHES)	ZINC ANODE WEIGHT (LBS)
1	0 TO 45	1.4 X 1.4 X 30	15
1	45 TO 90	2.0 X 2.0 X 30	30
2	0 TO 22	1.4 X 1.4 X 30	15
2	22 TO 45	2.0 X 2.0 X 30	30
2	45 TO 70	2.0 X 2.0 X 48	40
2	70 TO 90	2.0 X 2.0 X 60	60

- | ITEM | MATERIALS |
|------|---|
| 1 | LINEAR LOW DENSITY POLYETHYLENE VENTED PIPE COVER, SEE NOTE 1. 20" DIA. X 36" HIGH COVER FOR 1" AND 2" SIZE. |
| 2 | 1" OR 2" AIR RELEASE & VACUUM RELIEF VALVE, SEE NOTES 2, 3, AND 4. |
| 3 | 1" OR 2" WROT COPPER ADAPTER, SWEAT X M.I.P.T. |
| 4 | 1" OR 2" BRASS BALL CORP WITHOUT "STOPS" AND WITH 2" SQUARE OPERATING NUT ADAPTER ATTACHED WITH STAINLESS STEEL BOLT AND NUT. |
| 5 | 1" OR 2" WROT COPPER ADAPTER, F.I.P.T. X SWEAT. |
| 6 | COLD JOINT STRIP WHEN ADJACENT TO SIDEWALK. |
| 7 | 1" OR 2" 90° WROT COPPER 90° BEND, SWEAT X SWEAT. |
| 8 | VALVE BOX PER IRWD STD. DWG. W-22. |
| 9 | 1" OR 2" SERVICE CONNECTION PER IRWD STD. DWG. W-3. |
| 10 | SCH 80 PVC NIPPLE, M.I.P.T. X M.I.P.T., 6" LONG. |
| 11 | 1" OR 2" COPPER SERVICE PIPE, TYPE "K" RIGID. |
| 12 | PRE-FABRICATED PVC OUTLET WITH RIGID STAINLESS STEEL SCREEN M.I.P.T. INLET. |
| 13 | 2" OR 4" SCH 40 PVC SLEEVE, SEE NOTE 6. |
| 14 | CLASS "B" CONCRETE PAD REINFORCED WITH W.W.F. 1.6 X 1.6 AND SUPPORT WHERE APPLICABLE PER CASE 1, 2, OR 3 AS SHOWN HEREON. |
| 15 | 1" OR 2" BRASS OR COPPER WIRE CLAMP. |
| 16 | AWG NO. 8 STRANDED COPPER ANODE LEAD WIRE; LEAVE 18" OF COILED WIRE IN VENTED PIPE COVER. |
| 17 | ZINC ANODE (SEE TABLE HEREON FOR SIZE OF ANODE) AND LEAD WIRE. ANODE TO BE PLACED VERTICALLY OR HORIZONTALLY AT LEAST 24" FROM THE COPPER PIPE. |
| 18 | IDENTIFICATION TAPE PER IRWD STD. SPEC. SECTION 15151. TAPE TO COPPER PIPE CIRCUMFERENTIALLY AT 2' INTERVALS USING 2" WIDE 10-MIL TAPE. LEAVE 18" OF TAPE ABOVE SURFACE OF CONCRETE PAD IN VENTED PIPE COVER. |
| 19 | 1" OR 2" BRASS AWWA BALL VALVE WITH BRASS LEVER HANDLE, F.I.P.T. X F.I.P.T. |
| 20 | 1/2" DIA. X 4" LONG TYPE 316 STAINLESS STEEL ANCHOR BOLT (3 EACH AT 120° APART WITH 2-PART EPOXY AND STAINLESS STEEL NUTS AND WASHERS). |
| 21 | FOR A 1" AIR RELEASE AND VACUUM RELIEF VALVE: 1/4" DIA. X 1" LONG STAINLESS STEEL NIPPLE AND 1/4" STAINLESS STEEL BALL VALVE. FOR A 2" AIR RELEASE AND VACUUM RELIEF VALVE: 3/8" DIA. X 1" LONG STAINLESS STEEL NIPPLE AND 3/8" STAINLESS STEEL BALL VALVE. |
| 22 | SCH 80 PVC COUPLING, F.I.P.T. X F.I.P.T., WITH 316 STAINLESS STEEL BAND. |

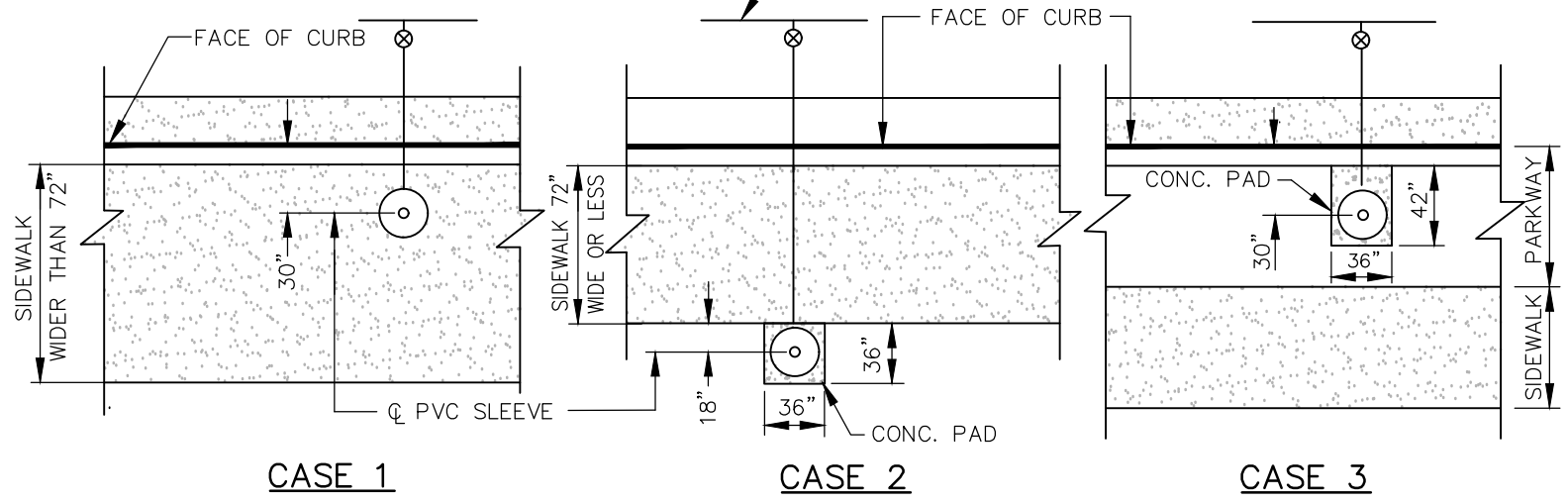
- NOTES:**
- INSTALL IRWD LOGO DECAL "DOMESTIC" OR "RECYCLED" AS DIRECTED BY IRWD. SEE IRWD STD. SPEC. SEC 15089 FOR COLOR OF VENTED PIPE COVER.
 - SEE STD. SPEC. SECTION 15089 FOR ACCEPTABLE PRODUCTS.
 - POSITION ASSEMBLY PER APPLICABLE CASE 1, 2, OR 3 AS SHOWN HEREON.
 - THE DISTRICT WILL DETERMINE IF 1" OR 2" ASSEMBLY IS TO BE INSTALLED. REFER TO PROJECT PLANS.
 - MARK BALL CORP LOCATION AND DISTANCES TO TWO POINTS ON ADJACENT CURB BY USE OF A 4" WHEEL GRINDER. SEE IRWD STD. DWG. S-1 FOR SIMILAR APPLICATION.
 - FILL ANNULAR SPACE WITH SAND PER IRWD STD. SPEC. SECTION 02223.



1" OR 2" AIR RELEASE AND VACUUM RELIEF (PVC PIPE)		 IRWD STD. DWG. W-11
IRVINE RANCH WATER DISTRICT, ENGINEERING DEPARTMENT APPROVED BY:  KEVIN L. BURTON R.M.E. M28832 EXECUTIVE DIRECTOR, TECHNICAL SERVICES		
		IRVINE RANCH WATER DISTRICT NOT TO SCALE SHEET 1 OF 4

ITEM MATERIALS

- 1 — LINEAR LOW DENSITY POLYETHYLENE VENTED PIPE COVER, SEE NOTE 1. 20" DIA. X 36" HIGH COVER FOR 1" AND 2" SIZE.
- 2 — 1" OR 2" AIR RELEASE & VACUUM RELIEF VALVE, SEE NOTES 2, 3, AND 4.
- 3 — 1" OR 2" WROT COPPER ADAPTER, SWEAT X M.I.P.T.
- 4 — 1" OR 2" BRASS BALL CORP WITHOUT "STOPS" AND WITH 2" SQUARE OPERATING NUT ADAPTER ATTACHED WITH STAINLESS STEEL BOLT AND NUT.
- 5 — 1" OR 2" WROT COPPER ADAPTER, F.I.P.T. X SWEAT.
- 6 — COLD JOINT STRIP WHEN ADJACENT TO SIDEWALK.
- 7 — 1" OR 2" WROT COPPER 90° BEND, SWEAT X SWEAT.
- 8 — VALVE BOX PER IRWD STD. DWG. W-22.
- 9 — 1" OR 2" SERVICE CONNECTION PER IRWD STD. DWG. W-3.
- 10 — 1" OR 2" SCH 80 PVC NIPPLE, 2" LONG.
- 11 — 1" OR 2" COPPER SERVICE PIPE, TYPE "K" RIGID.
- 12 — PRE-FABRICATED PVC OUTLET WITH RIGID STAINLESS STEEL SCREEN M.I.P.T. INLET.
- 13 — 2" OR 4" SCH 40 PVC SLEEVE, SEE NOTE 6.
- 14 — CLASS "B" CONCRETE PAD AND SUPPORT WHERE APPLICABLE PER CASE 1, 2, OR 3 AS SHOWN HEREON.
- 15 — 1" OR 2" BRASS OR COPPER WIRE CLAMP.
- 16 — AWG NO. 8 STRANDED COPPER ANODE LEAD WIRE, LEAVE 18" OF COILED WIRE IN VENTED PIPE COVER.
- 17 — ZINC ANODE (SEE TABLE HEREON FOR SIZE OF ANODE) AND LEAD WIRE. ANODE TO BE PLACED VERTICALLY OR HORIZONTALLY AT LEAST 24" FROM THE COPPER PIPE.
- 18 — 1" OR 2" SCH 80 PVC NIPPLE, SLIP X SLIP.
- 19 — 1" OR 2" SCH 80 PVC 90° BEND, SWEAT X F.I.P.T.
- 20 — SCH 80 PVC NIPPLE M.I.P.T. X M.I.P.T., 6" LONG.
- 21 — 1" OR 2" BRASS AWWA BALL VALVE WITH BRASS LEVER HANDLE, F.I.P.T. X F.I.P.T.
- 22 — 1/2" X 2" SCH 40 SST NIPPLE, 1/2" SST 90° BEND, AND 1/2" SST BALL VALVE.
- 23 — IDENTIFICATION TAPE PER IRWD STD. SPEC. SECTION 15151. TAPE TO COPPER PIPE CIRCUMFERENTIALLY AT 2' INTERVALS USING 2" WIDE 10-MIL TAPE. LEAVE 18" OF TAPE ABOVE SURFACE OF CONCRETE PAD IN VENTED PIPE COVER.
- 24 — 1/2" DIA. X 4" LONG TYPE 316 STAINLESS STEEL ANCHOR BOLT (3 EACH AT 120° APART WITH 2-PART EPOXY AND STAINLESS STEEL NUTS AND WASHERS).

ZINC ANODE SIZES FOR 1" AND 2" COPPER PIPE

COPPER PIPE SIZE (INCHES)	COPPER PIPE LENGTH (FEET)	ZINC ANODE SIZE (INCHES)	ZINC ANODE WEIGHT (LBS)
1	0 TO 45	1.4 X 1.4 X 30	15
1	45 TO 90	2.0 X 2.0 X 30	30
2	0 TO 22	1.4 X 1.4 X 30	15
2	22 TO 45	2.0 X 2.0 X 30	30
2	45 TO 70	2.0 X 2.0 X 48	40
2	70 TO 90	2.0 X 2.0 X 60	60

1/2" Ø X 4" STAINLESS STEEL ANCHOR BOLT (2 EACH AT 180° APART)

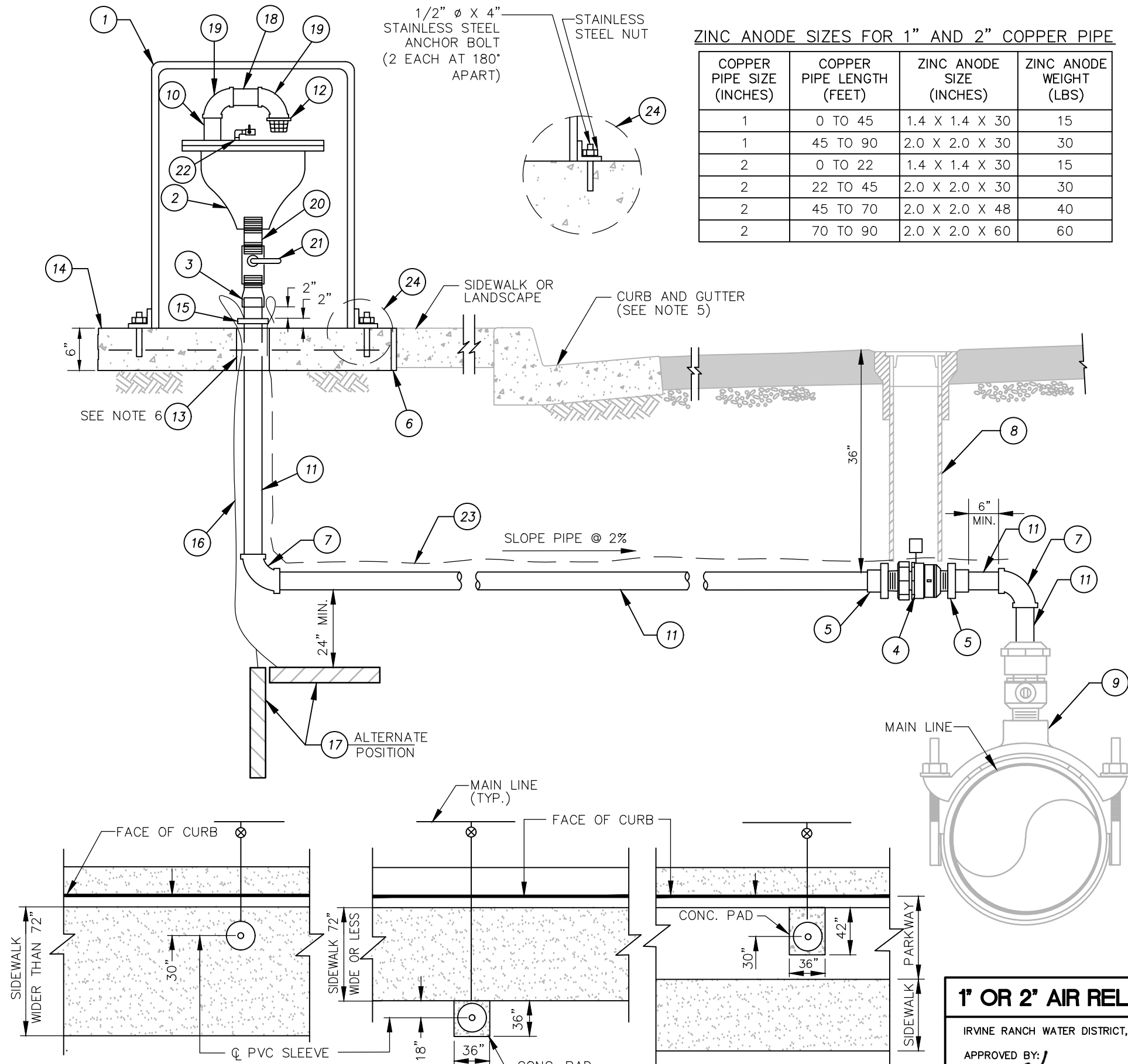
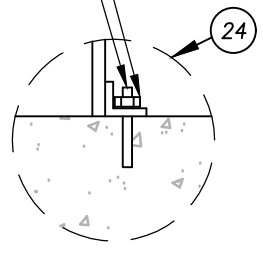

- NOTES:**
1. INSTALL IRWD LOGO DECAL "DOMESTIC" OR "RECYCLED" AS DIRECTED BY IRWD.
 2. SEE IRWD STD. SPEC. SECTION 15089 FOR ACCEPTABLE PRODUCTS.
 3. POSITION ASSEMBLY PER APPLICABLE CASE 1, 2, OR 3 AS SHOWN HEREON.
 4. THE DISTRICT WILL DETERMINE IF 1" OR 2" ASSEMBLY IS TO BE INSTALLED. REFER TO PROJECT PLANS.
 5. MARK BALL CORP LOCATION AND DISTANCES TO TWO POINTS ON ADJACENT CURB BY USE OF A 4" WHEEL GRINDER. SEE IRWD STD. DWG. S-1 FOR SIMILAR APPLICATION.
 6. FILL ANNULAR SPACE WITH SAND PER IRWD STD. SPEC. SECTION 02223.

1" OR 2" AIR RELEASE AND VACUUM RELIEF (PVC PIPE)			IRWD STD. DWG. W-11
IRVINE RANCH WATER DISTRICT, ENGINEERING DEPARTMENT APPROVED BY: KEVIN L. BURTON R.M.E. M28832 EXECUTIVE DIRECTOR, TECHNICAL SERVICES			FEBRUARY 2025 REVISION

ITEM MATERIALS

- 1 4" FLANGED OUTLET PER IRWD STD. DWG. W-3.
- 2 4" FLANGED 90° ELBOW (SAME MATERIAL AS MAIN LINE).
- 3 4" BUTTERFLY VALVE, F.E. x F.E.
- 4 VALVE AND VALVE BOX INSTALLATION PER IRWD STD. DWG W-22.
- 5 VALVE STEM EXTENSION PER IRWD STD. DWG W-23 (WHERE REQUIRED).
- 6 4" X 1" OR 2" TAPPED D.I. COMPANION FLANGE.
- 7 1" OR 2" BRASS INSULATING BALL CORPORATION STOP PER IRWD STD. DWG. W-3.
- 8 1" OR 2" COPPER SERVICE PIPE, TYPE "K" RIGID.
- 9 1" OR 2" SWEAT COPPER 90° BEND.
- 10 1" OR 2" BRASS AWWA BALL VALVE WITH BRASS LEVER HANDLE, F.I.P.T. X F.I.P.T.
- 11 AWG NO. 8 STRANDED COPPER ANODE LEAD WIRE, LEAVE 18" OF COILED WIRE IN VENTED PIPE COVER.
- 12 ZINC ANODE (SEE TABLE HEREON FOR SIZE OF ANODE) AND LEAD WIRE. ANODE TO BE PLACED HORIZONTALLY AT LEAST 24" FROM THE COPPER PIPE.
- 13 2" OR 4" SCH 40 PVC SLEEVE, SEE NOTE 6.
- 14 CLASS "B" CONCRETE PAD REINFORCED WITH W.W.F. 1.6" X 1.6" AND SUPPORT WHERE APPLICABLE PER CASE 1, 2, OR 3 AS SHOWN HEREON.
- 15 COLD JOINT STRIP WHEN ADJACENT TO SIDEWALK.
- 16 1" OR 2" BRASS OR COPPER WIRE CLAMP.
- 17 1" OR 2" WROT COPPER ADAPTER M.I.P.T. X SWEAT.
- 18 SCH 80 PVC NIPPLE, M.I.P.T. X M.I.P.T., 6" LONG.
- 19 1" OR 2" AIR RELEASE & VACUUM RELIEF VALVE, SEE NOTES 2, 3, AND 4.
- 20 LINEAR LOW DENSITY POLYETHYLENE VENTED PIPE COVER, SEE NOTE 1. 20" DIA. X 36" HIGH COVER FOR 1" AND 2" SIZE.
- 21 IDENTIFICATION TAPE PER IRWD STD. SPEC. SECTION 15151. TAPE TO COPPER PIPE CIRCUMFERENTIALLY AT 2' INTERVALS USING 2" WIDE 10-MIL TAPE. LEAVE 18" OF TAPE ABOVE SURFACE OF CONCRETE PAD IN VENTED PIPE COVER.
- 22 PRE-FABRICATED PVC OUTLET WITH RIGID STAINLESS STEEL SCREEN M.I.P.T. INLET.
- 23 FOR A 1" AIR RELEASE AND VACUUM RELIEF VALVE: 1/4" DIA. X 1" LONG STAINLESS STEEL NIPPLE AND 1/4" STAINLESS STEEL BALL VALVE. FOR A 2" AIR RELEASE AND VACUUM RELIEF VALVE: 3/8" DIA. X 1" LONG STAINLESS STEEL NIPPLE AND 3/8" STAINLESS STEEL BALL VALVE.
- 24 SCH 80 PVC COUPLING, F.I.P.T. X F.I.P.T., WITH 316 STAINLESS STEEL BAND.
- 25 4" X 6" FLANGED PIPE SPOOL (SAME MATERIAL AS MAIN LINE).

ZINC ANODE SIZES FOR 1" AND 2" COPPER PIPE

COPPER PIPE SIZE (INCHES)	COPPER PIPE LENGTH (FEET)	ZINC ANODE SIZE (INCHES)	ZINC ANODE WEIGHT (LBS)
1	0 TO 45	1.4 X 1.4 X 30	15
1	45 TO 90	2.0 X 2.0 X 30	30
2	0 TO 22	1.4 X 1.4 X 30	15
2	22 TO 45	2.0 X 2.0 X 30	30
2	45 TO 70	2.0 X 2.0 X 48	40
2	70 TO 90	2.0 X 2.0 X 60	60

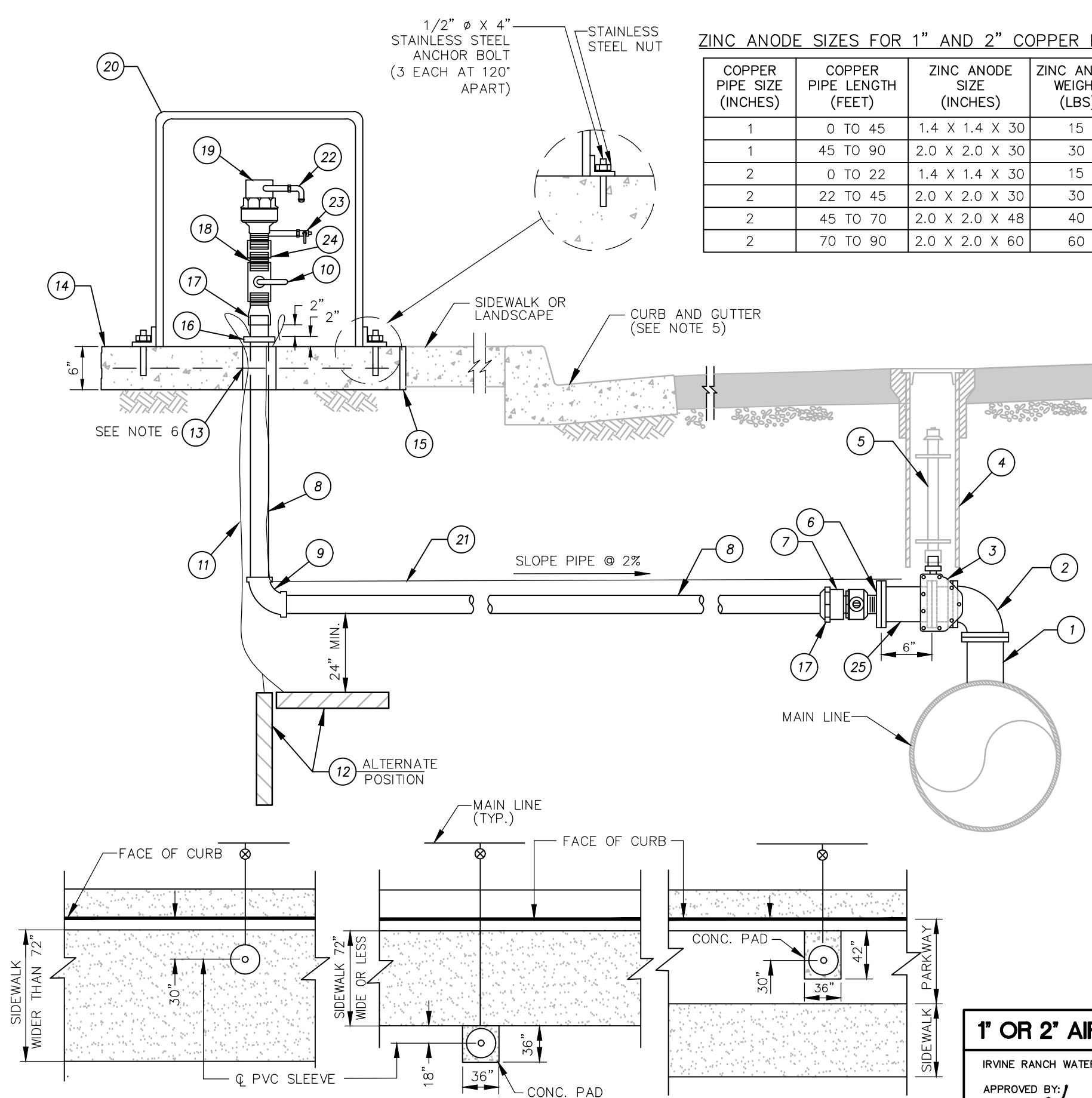

NOTES:

1. INSTALL IRWD LOGO DECAL "DOMESTIC" OR "RECYCLED" AS DIRECTED BY IRWD. SEE IRWD STD. SPEC. SEC 15089 FOR COLOR OF VENTED PIPE COVER.
2. SEE SPECIFICATION SECTION 15089 FOR ACCEPTABLE PRODUCTS.
3. POSITION ASSEMBLY PER APPLICABLE CASE 1, 2, OR 3 AS SHOWN HEREON.
4. THE DISTRICT WILL DETERMINE IF 1" OR 2" ASSEMBLY IS TO BE INSTALLED. REFER TO PROJECT PLANS.
5. MARK BUTTERFLY VALVE LOCATION AND DISTANCES TO TWO POINTS ON ADJACENT CURB BY USE OF A 4" WHEEL GRINDER. SEE IRWD STD. DWG. S-1 FOR SIMILAR APPLICATION.
6. FILL ANNULAR SPACE WITH SAND PER IRWD STD. SPEC. SECTION 02223.

1" OR 2" AIR RELEASE AND VACUUM RELIEF (STEEL PIPE OR DIP)

IRVINE RANCH WATER DISTRICT, ENGINEERING DEPARTMENT
 APPROVED BY:

 KEVIN L. BURTON R.M.E. M28832
 EXECUTIVE DIRECTOR, TECHNICAL SERVICES

FEBRUARY 2025
 REVISION



**IRWD
 STD. DWG.
 W-11**

NOT TO SCALE
 SHEET 3 OF 4

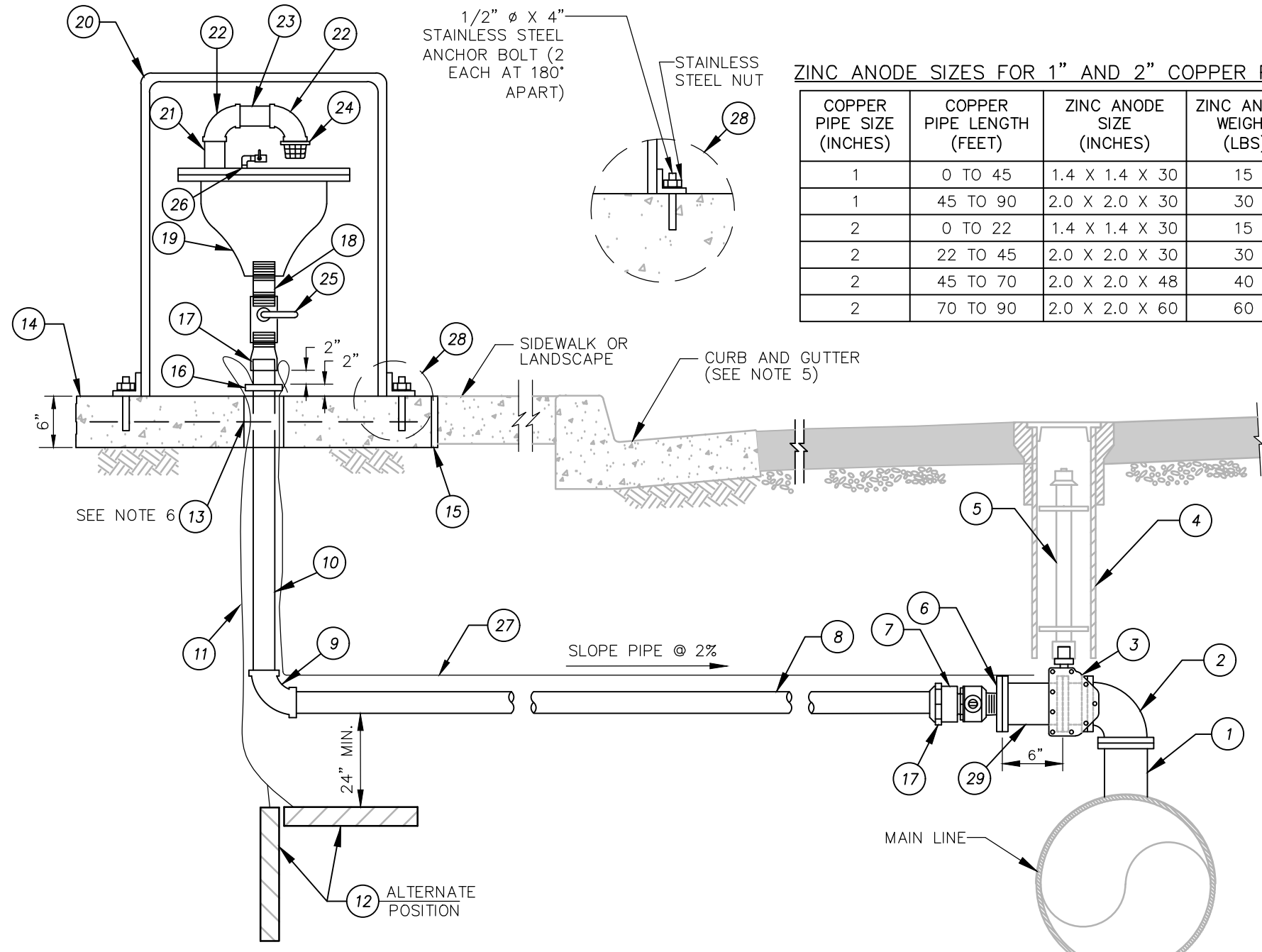

1/2" Ø X 4"
STAINLESS STEEL
ANCHOR BOLT (2
EACH AT 180°
APART)

STAINLESS
STEEL NUT

ZINC ANODE SIZES FOR 1" AND 2" COPPER PIPE

COPPER PIPE SIZE (INCHES)	COPPER PIPE LENGTH (FEET)	ZINC ANODE SIZE (INCHES)	ZINC ANODE WEIGHT (LBS)
1	0 TO 45	1.4 X 1.4 X 30	15
1	45 TO 90	2.0 X 2.0 X 30	30
2	0 TO 22	1.4 X 1.4 X 30	15
2	22 TO 45	2.0 X 2.0 X 30	30
2	45 TO 70	2.0 X 2.0 X 48	40
2	70 TO 90	2.0 X 2.0 X 60	60

- | ITEM | MATERIALS |
|------|---|
| 1 | 4" FLANGED OUTLET. |
| 2 | 4" FLANGED 90° ELBOW (SAME MATERIAL AS MAIN LINE). |
| 3 | 4" BUTTERFLY VALVE, F.E. X F.E. |
| 4 | VALVE AND VALVE BOX INSTALLATION PER IRWD STD. DWG. W-22. |
| 5 | VALVE STEM EXTENSION PER IRWD STD. DWG. W-23 (WHERE REQUIRED). |
| 6 | 4" X 1" OR 2" TAPPED COMPANION FLANGE (STEEL OR D.I.). |
| 7 | 1" OR 2" BRASS BALL INSULATING CORPORATION STOP PER IRWD STD. DWG. W-3. |
| 8 | 1" OR 2" COPPER SERVICE PIPE, TYPE "K" RIGID. |
| 9 | 1" OR 2" SWEAT COPPER 90° BEND. |
| 10 | 1" OR 2" COPPER SERVICE PIPE, TYPE "K" RIGID. |
| 11 | AWG NO. 8 STRANDED COPPER ANODE LEAD WIRE, LEAVE 18" OF COILED WIRE IN VENTED PIPE COVER. |
| 12 | ZINC ANODE (SEE TABLE HEREON FOR SIZE OF ANODE) AND LEAD WIRE. ANODE TO BE PLACED HORIZONTALLY AT LEAST 24" FROM THE COPPER PIPE. |
| 13 | 2" OR 4" SCH 40 PVC SLEEVE. |
| 14 | CLASS "B" CONCRETE PAD AND SUPPORT WHERE APPLICABLE PER CASE 1, 2, OR 3 AS SHOWN HEREON. |
| 15 | COLD JOINT STRIP WHEN ADJACENT TO SIDEWALK. |
| 16 | 1" OR 2" BRASS OR COPPER WIRE CLAMP. |
| 17 | 1" OR 2" WROT COPPER ADAPTER M.I.P.T. X SWEAT. |
| 18 | SCH 80 PVC NIPPLE, M.I.P.T. X M.I.P.T., 6" LONG. |
| 19 | 1" OR 2" AIR RELEASE & VACUUM RELIEF VALVE, SEE NOTES 2, 3, AND 4. |
| 20 | LINEAR LOW DENSITY POLYETHYLENE VENTED PIPE COVER, SEE NOTE 1. 20" DIA. X 36" HIGH COVER FOR 1" AND 2" SIZE. |
| 21 | 1" OR 2" SCH 80 PVC NIPPLE, 2" LONG. |
| 22 | 1" OR 2" SCH 80 PVC 90° BEND, SLIP X F.I.P.T. |
| 23 | 1" OR 2" SCH 80 PVC NIPPLE, SLIP X SLIP. |
| 24 | PRE-FABRICATED PVC OUTLET WITH RIGID STAINLESS STEEL SCREEN M.I.P.T. INLET. |
| 25 | 1" OR 2" BRASS AWWA BALL VALVE WITH BRASS LEVER HANDLE, F.I.P.T. X F.I.P.T. |
| 26 | 1/2" X 2" SCH 40 SST NIPPLE, 1/2" SST 90° BEND, AND 1/2" SST BALL VALVE |
| 27 | IDENTIFICATION TAPE PER IRWD STD. SPEC. SECTION 15151. TAPE TO COPPER PIPE CIRCUMFERENTIALLY AT 2' INTERVALS USING 2" WIDE 10-MIL TAPE. LEAVE 18" OF TAPE ABOVE SURFACE OF CONCRETE PAD IN VENTED PIPE COVER. |
| 28 | 1/2" DIA. X 4" LONG TYPE 316 STAINLESS STEEL ANCHOR BOLT (3 EACH AT 120° APART WITH 2-PART EPOXY AND STAINLESS STEEL NUTS AND WASHERS). |
| 29 | 4" X 6" FLANGED PIPE SPOOL (SAME MATERIAL AS MAIN LINE). |

- NOTES:**
- INSTALL IRWD LOGO DECAL "DOMESTIC" OR "RECYCLED" AS DIRECTED BY IRWD.
 - SEE IRWD STD. SPEC. SECTION 15089 FOR ACCEPTABLE PRODUCTS.
 - POSITION ASSEMBLY PER APPLICABLE CASE 1, 2, OR 3 AS SHOWN HEREON.
 - THE DISTRICT WILL DETERMINE IF 1" OR 2" ASSEMBLY IS TO BE INSTALLED. REFER TO PROJECT PLANS.
 - MARK BUTTERFLY VALVE LOCATION AND DISTANCES TO TWO POINTS ON ADJACENT CURB BY USE OF A 4" WHEEL GRINDER. SEE IRWD STD. DWG. S-1 FOR SIMILAR APPLICATION.
 - FILL ANNULAR SPACE WITH SAND PER IRWD STD. SPEC. SECTION 02223.

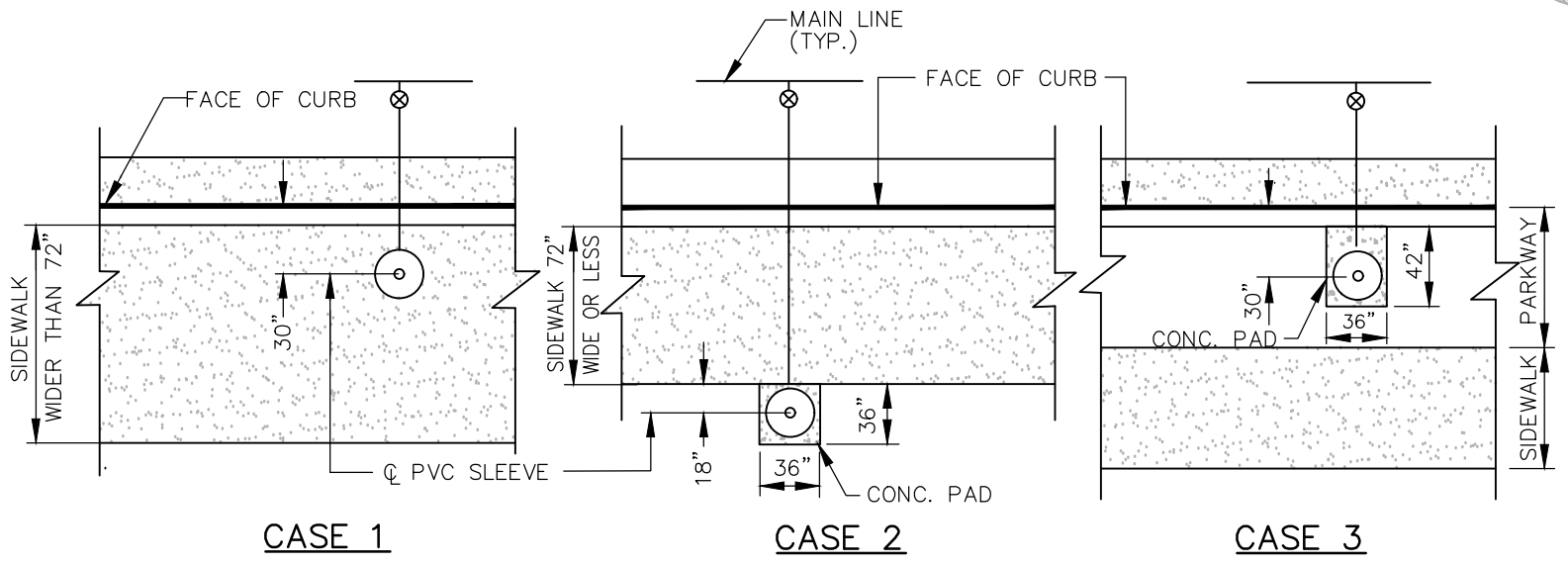

1" OR 2" AIR RELEASE AND VACUUM RELIEF (STEEL PIPE OR DIP)

IRVINE RANCH WATER DISTRICT, ENGINEERING DEPARTMENT

APPROVED BY: *Kevin L. Burton*

KEVIN L. BURTON R.M.E. M28832
EXECUTIVE DIRECTOR, TECHNICAL SERVICES

FEBRUARY 2025
REVISION

IRWD STD. DWG. W-11

NOT TO SCALE
SHEET 4 OF 4

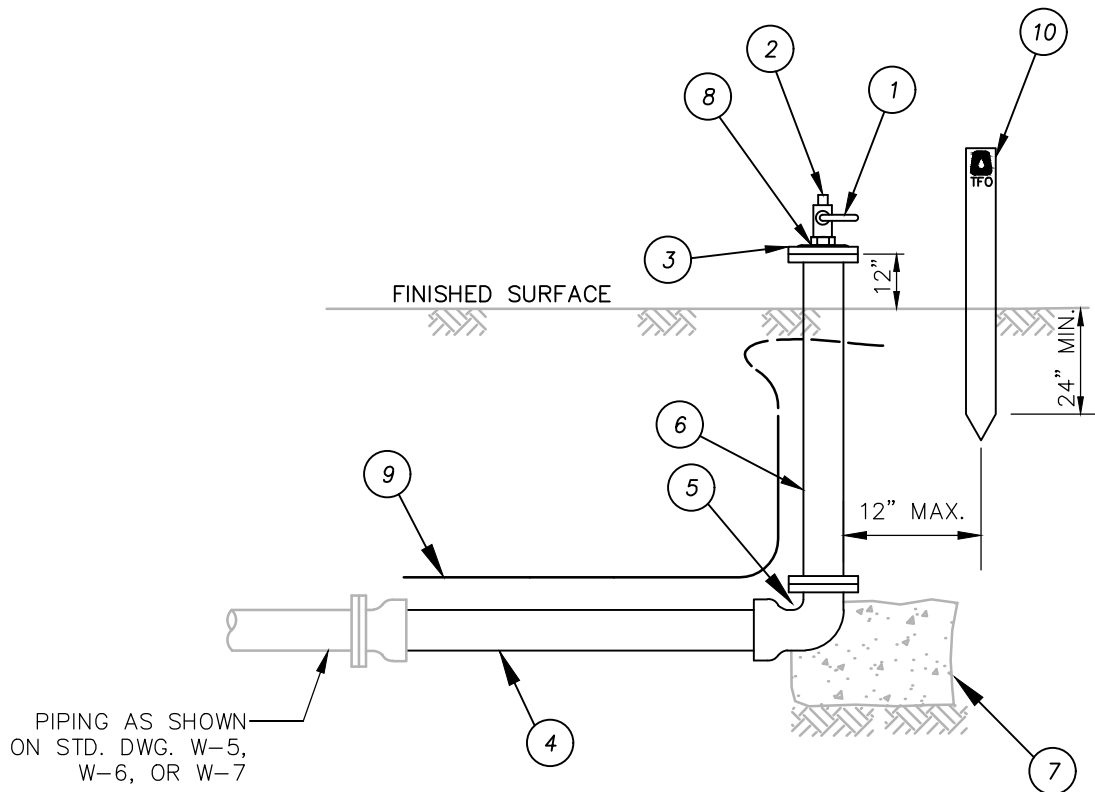

MAIN	LATERAL	RISER
4" - 16"	4"	4"
18" - 24"	6"	6"

ITEM

MATERIALS

- ① — 2" STAINLESS STEEL BALL VALVE WITH LEVER HANDLE, F.I.P.T. X F.I.P.T.
- ② — 2" THREADED STAINLESS STEEL PLUG.
- ③ — D.I. BLIND FLANGE TAPPED WITH 2" F.I.P.T.
- ④ — C-900 DR 14 OR DR 18 PVC LATERAL PIPE (DEPENDING ON PIPE SIZE).
- ⑤ — D.I. 90° BEND, F.E. X P.O.
- ⑥ — DIP F.E. X F.E. RISER SPOOL.
- ⑦ — THRUST BLOCK PER IRWD STD. DWG. W-16.
- ⑧ — 2" STAINLESS STEEL CLOSE NIPPLE, M.I.P.T., T.B.E.
- ⑨ — IDENTIFICATION TAPE PER IRWD STD. SPEC. SECTION 15151. TAPE TO PIPE CIRCUMFERENTIALLY AT 5' INTERVALS USING 2" WIDE 10-MIL TAPE.
- ⑩ — UTILITY MARKER PER IRWD STD. DWG. G-2 INDICATING LOCATION OF BURIED ASSEMBLY LABELED "TFO". LOCATE WITHIN 12" OF RISER.

NOTES:

1. TEMPORARY FLUSH-OUT ASSEMBLY REQUIRED AT ALL TEMPORARY DEAD END LINES.
2. SEE IRWD STD. DWG. W-13 FOR TEMPORARY FLUSH-OUT REQUIRED FOR TESTING AND FILLING OF MAIN LINES.
3. FOR FILLING OF NEW MAIN LINES, USE BACKFLOW DEVICE (CERTIFIED ANNUALLY). BACKFLOW DEVICE MUST BE DISINFECTED PRIOR TO USE AND PLACED 18" MIN. ABOVE FINISHED SURFACE.

TEMPORARY FLUSH-OUT ASSEMBLY

IRVINE RANCH WATER DISTRICT, ENGINEERING DEPARTMENT

APPROVED BY:

KEVIN L. BURTON R.M.E. M28832
EXECUTIVE DIRECTOR, TECHNICAL SERVICES

FEBRUARY 2025
REVISION



Irvine Ranch
WATER DISTRICT

**IRWD
STD. DWG.
W-12**

NOT TO SCALE
SHEET 1 OF 1

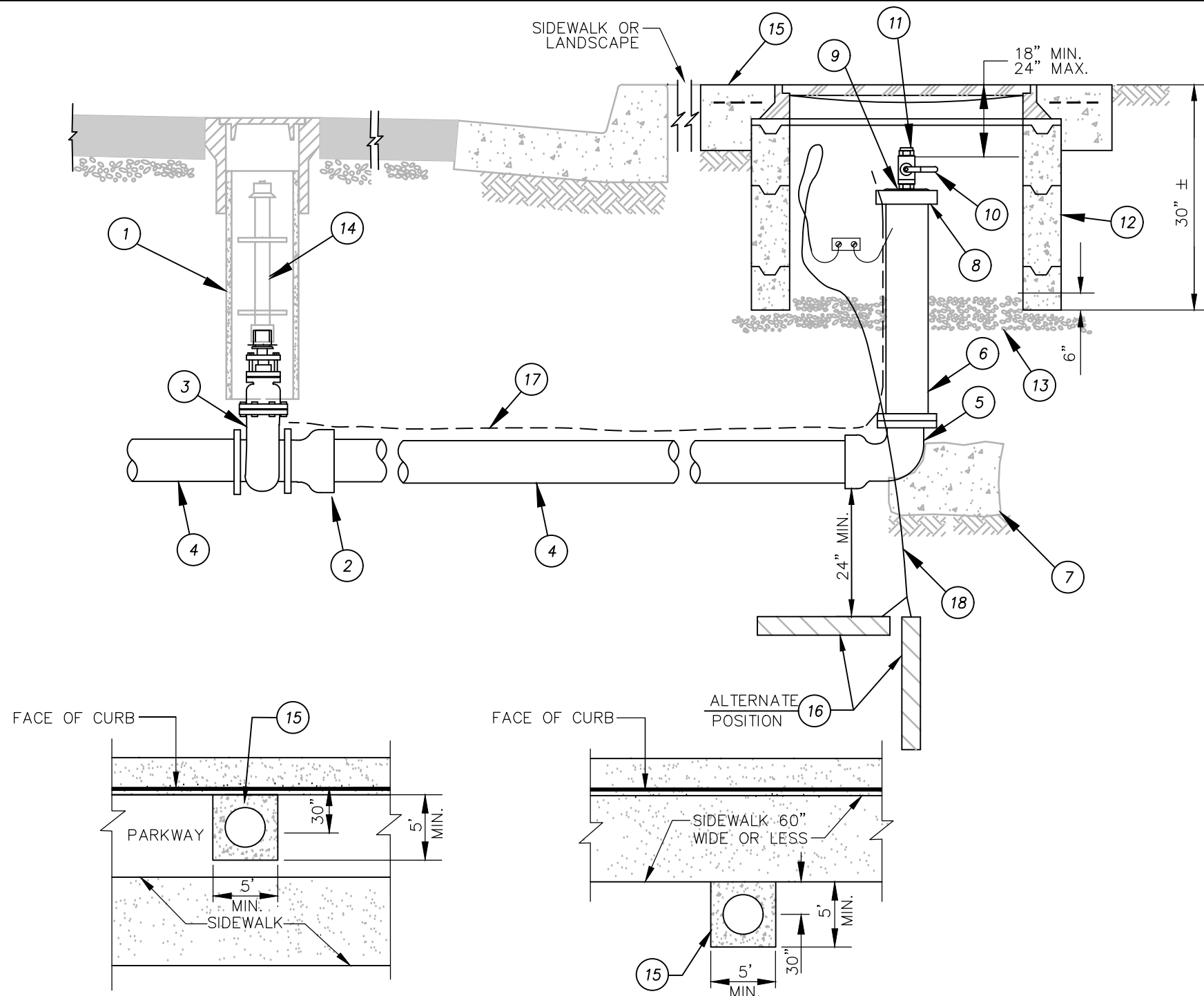

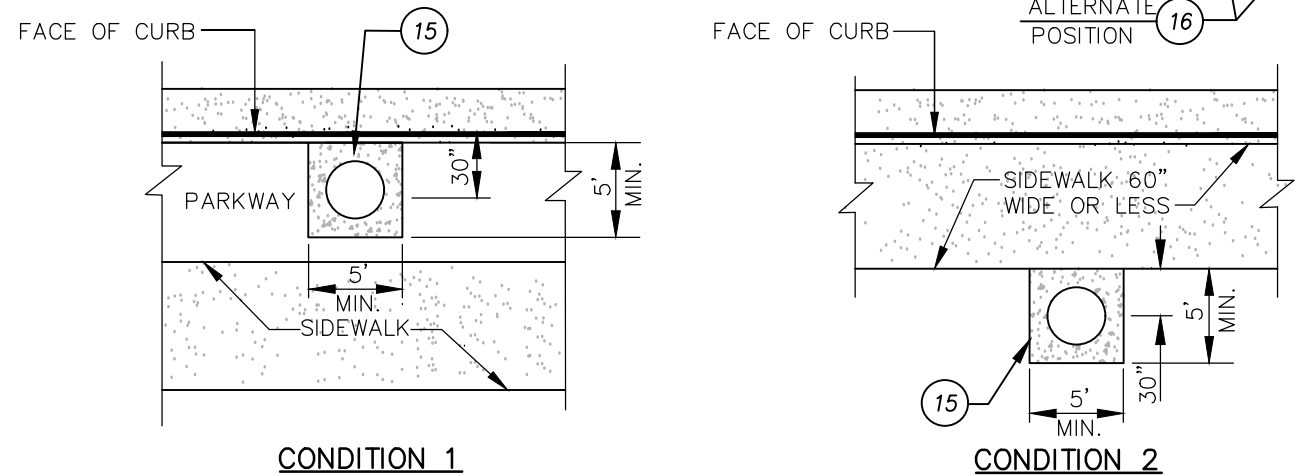

LATERAL AND RISER SCHEDULE		
MAIN	LATERAL	RISER
8" - 16"	4"	4"
18" - 24"	6"	6"
30"	8"	8"
36" - 48"	12"	12"

- | ITEM | MATERIALS |
|------|---|
| 1 | VALVE BOX PER IRWD STD. DWG. W-22. |
| 2 | D.I. F.E. X P.O. ADAPTER. |
| 3 | GATE VALVE, F.E. X F.E. |
| 4 | C-900 PVC DR 14 LATERAL PIPE. SIZE PER SCHEDULE. |
| 5 | D.I. 90° BEND, F.E. X P.O. |
| 6 | DIP, F.E. X F.E. RISER SPOOL (LENGTH AS REQUIRED). SIZE PER SCHEDULE. |
| 7 | THRUST BLOCK PER IRWD STD. DWG. W-16 (USE ONLY IF VALVE IS NOT BOLTED TO A FITTING). |
| 8 | D.I. COMPANION FLANGE. |
| 9 | 2" STAINLESS STEEL CLOSE NIPPLE M.I.P.T., T.B.E. |
| 10 | 2" STAINLESS STEEL BALL VALVE PER IRWD STD. SPEC. SECTION 15057. |
| 11 | 2" THREADED STAINLESS STEEL PLUG. |
| 12 | 30" MANHOLE WITH FRAME AND COVER WITH GRADE RINGS PER IRWD STD. DWG. S-1, WITH COVER MARKED "IRWD DOMESTIC WATER" OR "IRWD RECYCLED WATER" IN LIEU OF "SEWER". |
| 13 | 6" BASE OF 3/4" CRUSHED ROCK (EXTEND BEDDING 6" INTO VAULT). |
| 14 | VALVE STEM EXTENSION PER IRWD STD. DWG. W-23 (WHERE REQUIRED). |
| 15 | 5' X 5' CONCRETE PAD MIN. 6" THICK WITH W.W.F. 1.6 X 1.6. FOR 4' X 4' VAULT USE 7' X 7' PAD. |
| 16 | ZINC ANODE (60 LB.) AND LEAD WIRE. ANODE TO BE PLACED VERTICALLY OR HORIZONTALLY AT A MIN. SEPARATION OF 24" FROM THE PIPE. |
| 17 | IDENTIFICATION TAPE PER IRWD STD. SPEC. SECTION 15151. TAPE TO PIPE CIRCUMFERENTIALLY AT 2' INTERVALS USING 2" WIDE 10-MIL TAPE. |
| 18 | AWG NO. 8 STRANDED COPPER ANODE LEAD WIRE, PROVIDE AND CONNECT TO SHUNT, LEAVE 36" OF COILED WIRE BEFORE SHUNT IN VAULT. ALUMINO-THERMIC WELD PER IRWD STD. SPEC. SECTION 16640 AND IRWD STD. DWG. CP-8 AND CP-9. |



FLUSH-OUT ASSEMBLY LOCATION PLANS

- NOTES:**
- FLUSH-OUT ASSEMBLIES SHALL BE INSTALLED ON DEAD END PIPE WHERE FIRE HYDRANT ASSEMBLIES ARE NOT PRACTICAL.
 - MANHOLE SHALL BE WITHIN A DEDICATED IRWD EASEMENT OR PUBLIC RIGHT-OF-WAY.
 - PAINT RISER PIPING PER IRWD SPEC. SECTION 09900.
 - WHERE MAIN LINE PIPE MATERIAL (4) IS STEEL, USE OF CML&C STEEL FOR (2) (5) (6) AND (8) IS PERMITTED.
 - WHERE VAULTS OR MANHOLE FRAMES ARE OFFSET FROM CURB OR SIDEWALK, OR PLACED IN PARKWAYS, SET 2" ABOVE FINISHED SURFACE.
 - FOR TEMPORARY INSTALLATIONS REQUIRED FOR TESTING AND FILLING MAIN LINES, OMIT GATE VALVE, ZINC ANODES, AND SUBSTITUTE 30" MANHOLE FRAME AND COVER FOR 2" METER BOX PER IRWD STD. SPEC. SECTION 03462. 2" METER BOX SHALL BE LEFT 2" ABOVE FINISH GRADE.

FLUSH-OUT ASSEMBLY, FOR MAIN LINES 8" AND LARGER		
IRVINE RANCH WATER DISTRICT, ENGINEERING DEPARTMENT		
APPROVED BY: 	FEBRUARY 2025 REVISION	 IRWD STD. DWG. W-13
KEVIN L. BURTON R.M.E. M28832 EXECUTIVE DIRECTOR, TECHNICAL SERVICES	Irvine Ranch WATER DISTRICT	NOT TO SCALE SHEET 1 OF 2

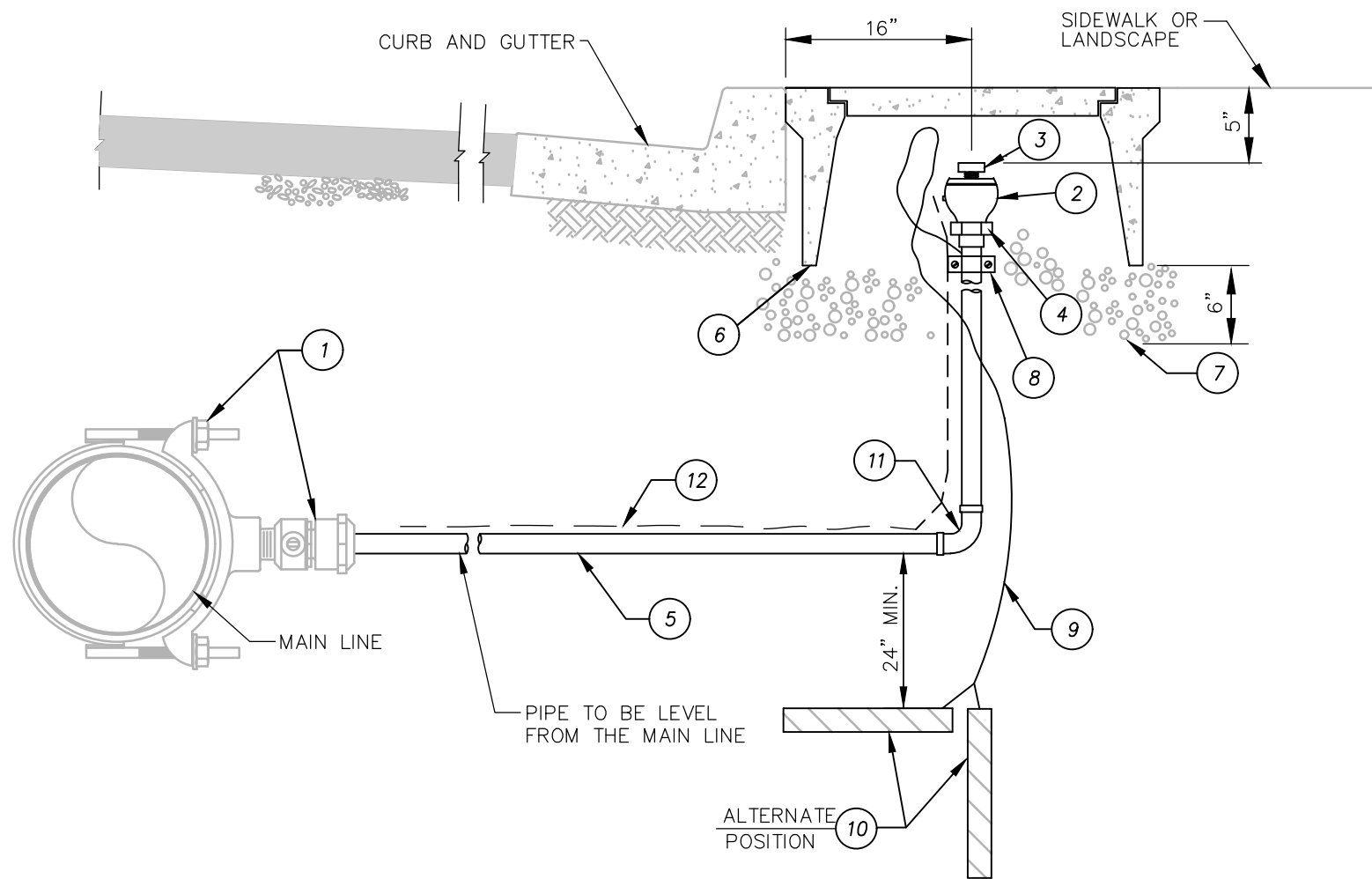

LOCATE LATERAL WITH 2" HIGH "FO" ON FACE OF CURB WHERE THE LATERAL CROSSES UNDER THE CURB. USE WHEEL GRINDER, 1/4" DEEP GROOVE.

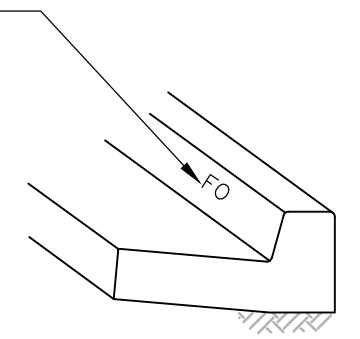

ZINC ANODE SIZES FOR 2" COPPER SERVICES

COPPER PIPE LENGTH (FEET)	ZINC ANODE SIZE (INCHES)	ZINC ANODE WEIGHT (LBS)
0 TO 22	1.4 X 1.4 X 30	15
22 TO 45	2.0 X 2.0 X 30	30
45 TO 70	2.0 X 2.0 X 48	40
70 TO 90	2.0 X 2.0 X 60	60

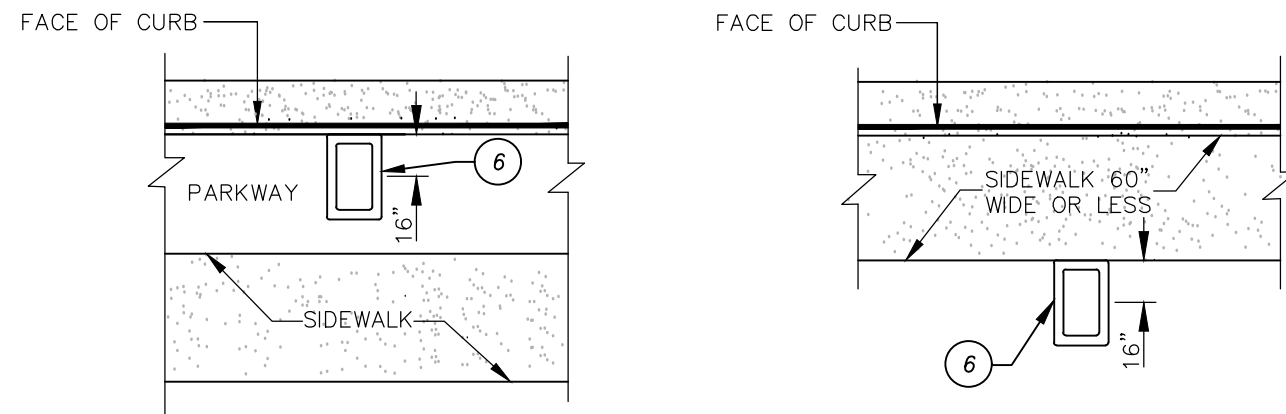

CONDITION 1
CONDITION 2
2" FLUSH-OUT ASSEMBLY LOCATION PLANS

- | ITEM | MATERIALS |
|------|---|
| 1 | 2" SERVICE CONNECTION PER IRWD STD. DWG. W-3. |
| 2 | 2" BRASS BALL CORPORATION STOP M.I.P.T. X M.I.P.T. (NORMALLY CLOSED) WITH 2" SQUARE OPERATING NUT ADAPTER ATTACHED WITH STAINLESS STEEL BOLT AND NUT. |
| 3 | 2" SCH 80 PVC CAP, F.I.P.T. |
| 4 | 2" SWEAT X F.I.P.T. ADAPTER. |
| 5 | 2" COPPER SERVICE PIPE TYPE "K" SOFT (COILED COPPER FOR 2" NOT ALLOWED). |
| 6 | METER BOX ONE PIECE LID. COMPOSITE POLYMER CONCRETE BOXES AND LIDS PER IRWD STD. SPEC. SECTION 03462. |
| 7 | 6" THICK BASE OF 3/4" CRUSHED ROCK. |
| 8 | GROUND WIRE CLAMP (SEE NOTE 5). |
| 9 | AWG NO. 8 STRANDED COPPER ANODE LEAD WIRE; LEAVE 18" OF COILED WIRE IN METER BOX. |
| 10 | ZINC ANODE (SEE TABLE HEREON FOR SIZE OF ANODE) AND LEAD WIRE. ANODE TO BE PLACED VERTICALLY OR HORIZONTALLY AT A MIN. SEPARATION OF 24" FROM THE COPPER SERVICE. |
| 11 | 2" WROT COPPER 90° BEND, SWEAT X SWEAT. |
| 12 | IDENTIFICATION TAPE PER IRWD STD. SPEC. SECTION 15151. TAPE TO PIPE CIRCUMFERENTIALLY AT 2' INTERVALS USING 2" WIDE 10-MIL TAPE. |

NOTES:

- SERVICE CONNECTION SHALL BE INSTALLED 18" FROM END OF MAIN LINE.
- SET TOP OF METER BOX FLUSH WITH SIDEWALK OR CURB AS SHOWN.
- THE WATER SERVICE SHALL EXTEND PERPENDICULAR TO THE CENTERLINE OF THE STREET FROM THE WATER MAIN TO THE METER STOP.
- METER BOX SHALL BE SET BEHIND SIDEWALK WHERE SIDEWALK IS ADJACENT TO CURB, OR IN PARKWAY BETWEEN CURB AND SIDEWALK.
- ANODE LEAD WIRE SHALL BE CLAMPED TO COPPER TUBING. CLAMP SHALL BE DIRECT BURIAL TYPE OF RED BRASS WITH STAINLESS STEEL SCREWS AND SHALL BE TESTED PER IRWD STD. SPEC. SECTION 16640 (SEE TABLE HEREON FOR ZINC ANODE SIZES).

FLUSH-OUT ASSEMBLY, FOR MAIN LINES 6' AND SMALLER

IRVINE RANCH WATER DISTRICT, ENGINEERING DEPARTMENT
 APPROVED BY:

 KEVIN L. BURTON R.M.E. M28832
 EXECUTIVE DIRECTOR, TECHNICAL SERVICES

FEBRUARY 2025
 REVISION



IRWD
STD. DWG.
W-13
 NOT TO SCALE
 SHEET 2 OF 2

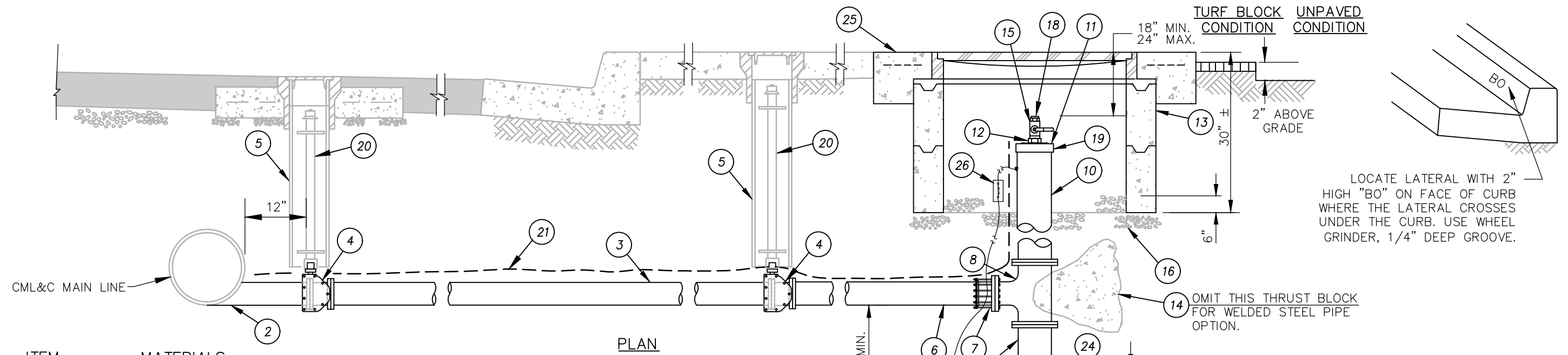

LOCATE LATERAL WITH 2" HIGH "BO" ON FACE OF CURB WHERE THE LATERAL CROSSES UNDER THE CURB. USE WHEEL GRINDER, 1/4" DEEP GROOVE.

OMIT THIS THRUST BLOCK FOR WELDED STEEL PIPE OPTION.

- | ITEM | MATERIALS |
|------|---|
| 1 | PIPE DIA. X 4" D.I. FLANGED TEE, FLANGED OUTLET, SEE NOTES 4, 6, AND 7. |
| 2 | 4" TO 12" SHOP FABRICATED CML&C STEEL FLANGED OUTLET, SEE NOTES 6 AND 7. |
| 3 | 4" TO 12" X LENGTH AS REQUIRED (12" MIN.) D.I. OR CML&C STEEL SPOOL, SEE NOTE 6. |
| 4 | 4" TO 12" RW BUTTERFLY VALVE, F.E. X F.E. |
| 5 | VALVE AND VALVE BOX INSTALLATION PER IRWD STD. DWG. W-22. |
| 6 | 4" TO 12" X LENGTH AS REQUIRED D.I. PIPE SPINDLE PIECE, F.E. X P.E. WITH MJ RETAINER GLAND OR CML&C STEEL SPOOL, F.E. X F.E., SEE NOTE 6. |
| 7 | 4" TO 12" D.I. FLANGED COUPLING ADAPTER (OMIT FOR STEEL PIPE). |
| 8 | 4" TO 12" X 8" TO 12" D.I. OR CML&C STEEL TEE, F.E. X F.E., SEE NOTE 6. |
| 9 | 8" TO 12" D.I. OR CML&C BLIND FLANGE, SEE NOTE 6. |
| 10 | 8" TO 12" X LENGTH AS REQUIRED D.I. PIPE SPINDLE PIECE, F.E. X F.E., SEE NOTES 6 AND 9. |
| 11 | G.E. CAP TAPPED WITH 2" F.I.P.T. |
| 12 | 2" STAINLESS STEEL CLOSE NIPPLE, M.I.P.T, T.B.E. |
| 13 | 30" MANHOLE WITH FRAME AND COVER, GRADE RINGS PER IRWD STD. DWG. S-1, WITH COVER MARKED "IRWD DW B.O." OR "IRWD RW B.O." IN LIEU OF "SEWER". |
| 14 | THRUST BLOCKS PER IRWD STD. DWG. W-16. |
| 15 | 2" STAINLESS STEEL BALL VALVE WITH LEVER HANDLE. |
| 16 | 12" BASE LAYER OF 3/4" CRUSHED ROCK, PLUS 6" OF ROCK INTO MANHOLE. |
| 17 | 8" TO 12" X 12" LONG D.I. OR CML&C STEEL SPOOL, F.E. X F.E., SEE NOTE 6. |
| 18 | 2" THREADED STAINLESS STEEL PLUG. |
| 19 | 8" TO 12" X 2" D.I. COMPANION FLANGE. |
| 20 | VALVE STEM EXTENSION PER IRWD STD. DWG. W-23 (WHERE REQUIRED). |
| 21 | IDENTIFICATION TAPE PER IRWD STD. SPEC. SECTION 15151. TAPE TO PIPE AT 2' INTERVALS USING 2" WIDE 10-MIL TAPE. |
| 22 | AWG NO. 8 STRANDED COPPER ANODE LEAD WIRE. ALUMINO-THERMIC WELD PER IRWD STD. SPEC. SECTION 16640 AND IRWD STD. DWG. CP-8 AND CP-9. |
| 23 | ZINC ANODE (60 LB) AND LEAD WIRE. ANODE TO BE PLACED VERTICALLY OR HORIZONTALLY AT A MIN. SEPARATION OF 24" FROM THE PIPE. ALUMINO-THERMIC WELD PER IRWD STD. SPEC. SECTION 16640 AND IRWD STD. DWG. CP-8 AND CP-9. |
| 24 | CONCRETE MATERIAL (MIN. 12" THICK). |
| 25 | 5' X 5' CONCRETE PAD MIN. 6" THICK WITH W.W.F. 1.6 X 1.6. |
| 26 | BRASS SHUNT WITH PLASTIC BASE, BY FARWEST CORROSION OR MESA PRODUCTS. MOUNT SHUNT TO WALL WITH 4" RED HEAD 316 SS ANCHORS. LEAVE 36" OF COILED WIRE ON EACH SIDE OF SHUNT. |

MAIN	LATERAL SIZE	RISER SIZE
4" - 6"	4"	8"
8" - 16"	4"	8"
18" - 24"	6"	8"
30"	8"	12"
36" - 48"	12"	12"

- NOTES:**
- IN UNPAVED AREAS, TOP OF MANHOLE SHALL BE RAISED TO MIN. 2" ABOVE FINISHED GRADE.
 - ONE VALVE SHALL BE PROVIDED FOR MAIN LINES LESS THAN 24" IN DIA. TWO VALVES SHALL BE PROVIDED FOR MAIN LINES 24" IN DIA. AND LARGER.
 - MANHOLE FRAME, COVER, GRADE RING, AND SHAFT SHALL BE LOCATED BEYOND THE SIDEWALK OR BEHIND CURB, SEE NOTE 8.
 - FOR DIP, SEE IRWD STD. DWG. CP-9.
 - INSTALL PIPE WITH ZERO SLOPE (LEVEL).
 - BLOWOFF ASSEMBLY PIPING MATERIALS SHALL MATCH THE TYPE OF MAIN LINE PIPING MATERIAL (I.E., STEEL WITH A STEEL MAIN, DUCTILE IRON WITH A DUCTILE IRON MAIN). IF MAIN LINE IS PVC, THEN USE EITHER STEEL OR DUCTILE IRON.
 - SEE DETAIL HEREON FOR DIP CONNECTION TO PVC OR DIP MAIN LINE DETAIL.
 - SEE SHEET 2 OF 2 FOR BLOWOFF/BOTTOM DRAIN LOCATION PLANS.
 - PAINT EXPOSED RISER PIPE PER IRWD STD. SPEC. SECTION 09900.
 - ALL JOINTS SHALL BE BONDED PER IRWD STD. SPEC. SECTION 16640.
 - AT NO POINT SHALL ANY PART OF THE BLOWOFF ASSEMBLY BE CLOSER THAN 36" AWAY FROM ANY STRUCTURE OR LANDSCAPING.

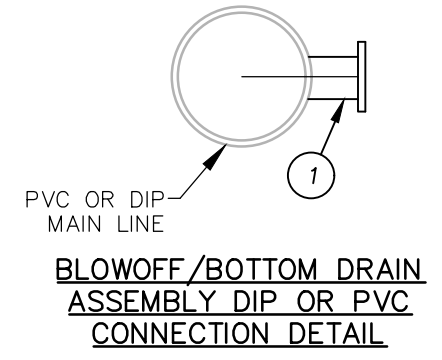

BLOWOFF/BOTTOM DRAIN ASSEMBLY

IRVINE RANCH WATER DISTRICT, ENGINEERING DEPARTMENT
 APPROVED BY:

 KEVIN L. BURTON R.M.E. M28832
 EXECUTIVE DIRECTOR, TECHNICAL SERVICES

FEBRUARY 2025
 REVISION



IRWD STD. DWG. W-14
 NOT TO SCALE
 SHEET 1 OF 2

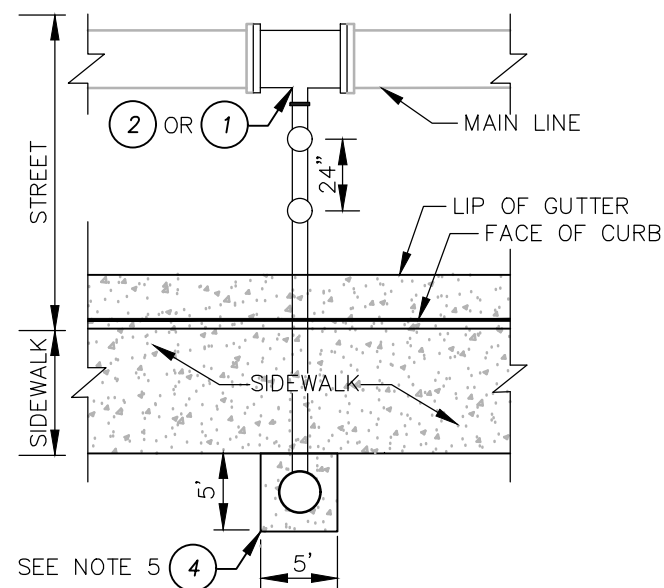

CASE 1

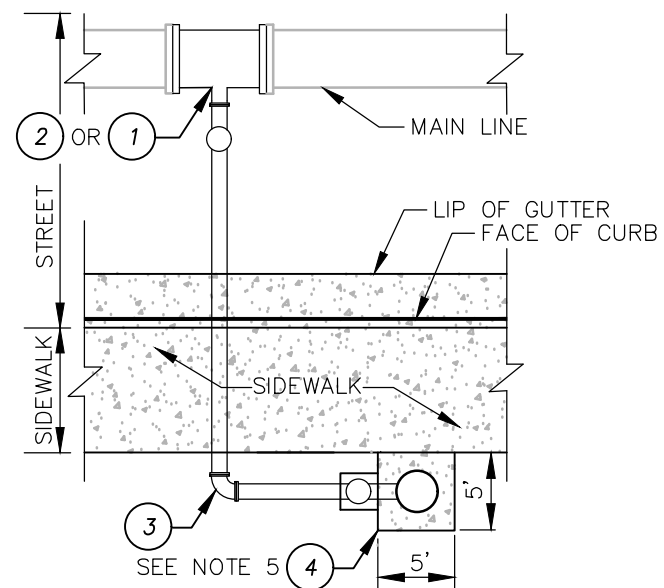

CASE 2

- | ITEM | MATERIALS |
|------|---|
| 1 | PIPE DIA. X 4" TO 12" D.I. FLANGED TEE AND FLANGED OUTLET, SEE NOTES 4, 6, AND 7 ON SHEET 1 OF 2. |
| 2 | 4" TO 12" SHOP FABRICATED CML&C STEEL FLANGED OUTLET, SEE NOTES 6 AND 7 ON SHEET 1 OF 2. |
| 3 | THRUST BLOCKS PER IRWD STD. DWG. W-16. |
| 4 | 5' X 5' CONCRETE PAD MIN. 6" THICK WITH W.W.F.-1.6 X 1.6. |

NOTES:

1. POSITION ASSEMBLY PER APPLICABLE CASE 1, 2, 3, OR 4 AS SHOWN HEREON.
2. ONE VALVE REQUIRED FOR MAIN LINES LESS THAN 24" IN DIA., TWO VALVES ARE REQUIRED FOR MAIN LINES 24" AND LARGER.
3. MANHOLE FRAME, COVER, GRADE RING, AND SHAFT SHALL BE LOCATED BEYOND THE SIDEWALK OR BEHIND CURB.
4. MARK VALVE LOCATION AND DISTANCES TO TWO POINTS ON ADJACENT CURB BY USE OF A 4" WHEEL GRINDER. SEE SHEET 1 OF 2.
5. BLOWOFF/BOTTOM DRAIN ASSEMBLY INSTALLATION IMPROVEMENTS BEYOND THE CITY OR COUNTY RIGHT-OF-WAY REQUIRE AN EASEMENT AS DIRECTED BY IRWD.

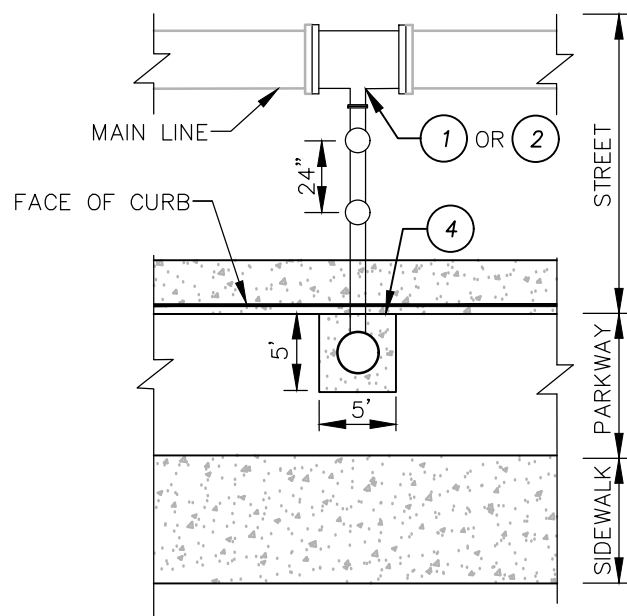

CASE 3

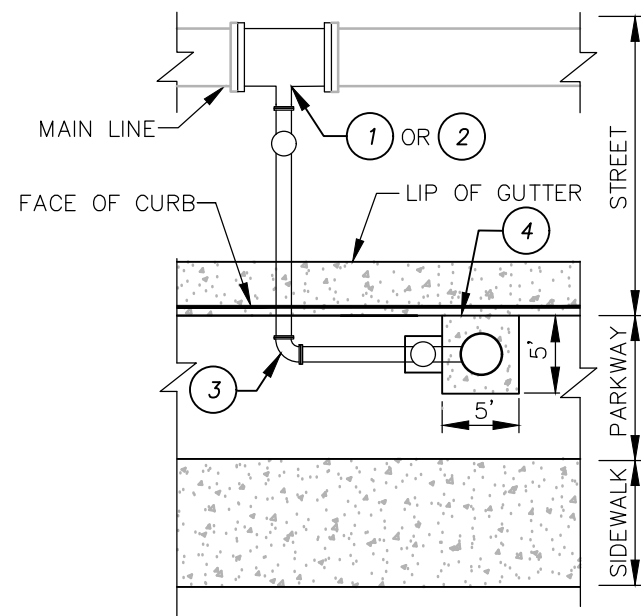

CASE 4

**BLOWOFF/BOTTOM DRAIN
LOCATION PLANS**

BLOWOFF/BOTTOM DRAIN ASSEMBLY LOCATION PLANS

IRVINE RANCH WATER DISTRICT, ENGINEERING DEPARTMENT

APPROVED BY:

Kevin L. Burton

KEVIN L. BURTON R.M.E. M28832
EXECUTIVE DIRECTOR, TECHNICAL SERVICES

FEBRUARY 2025
REVISION



**IRWD
STD. DWG.
W-14**

NOT TO SCALE
SHEET 2 OF 2

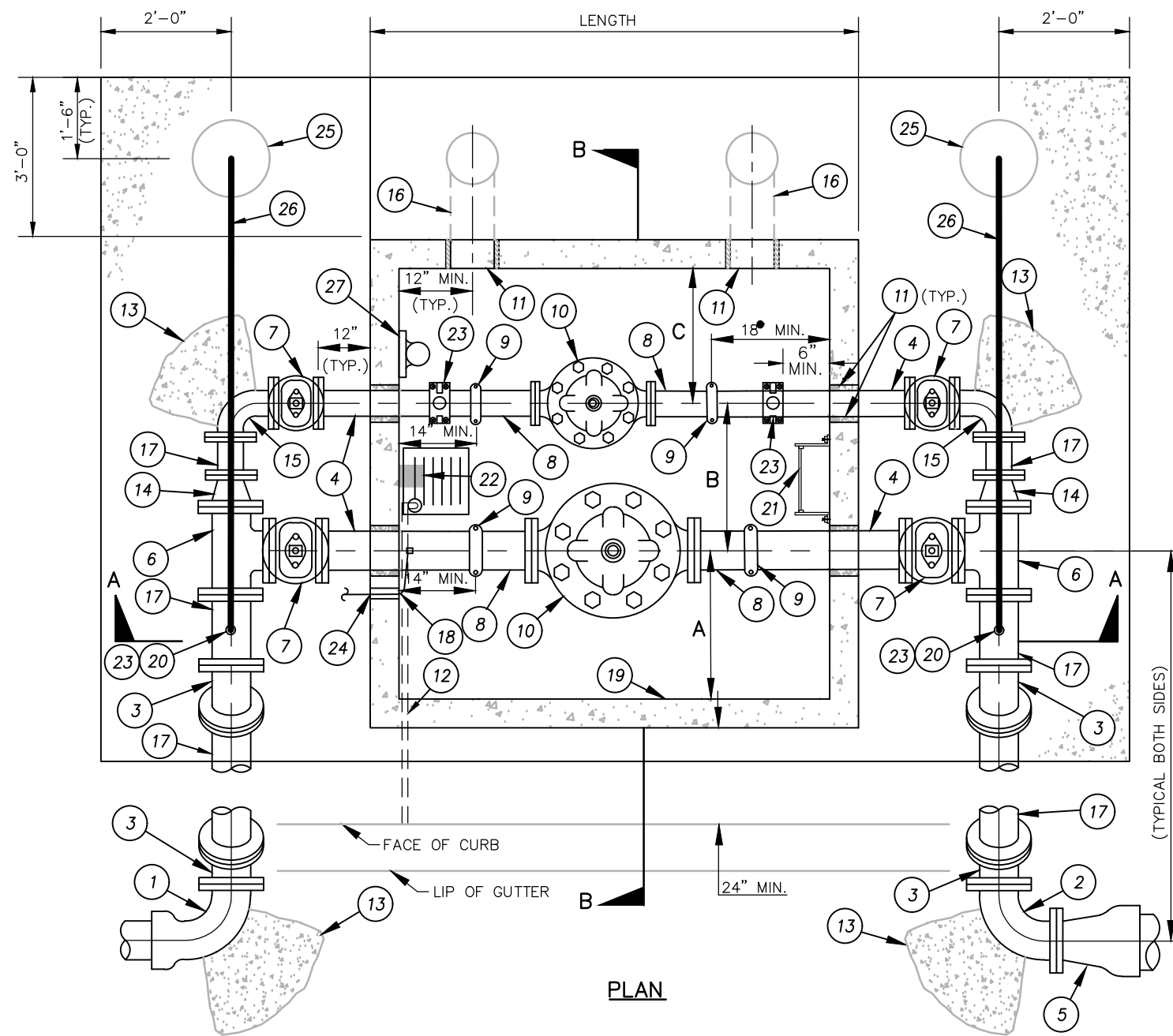

PLAN

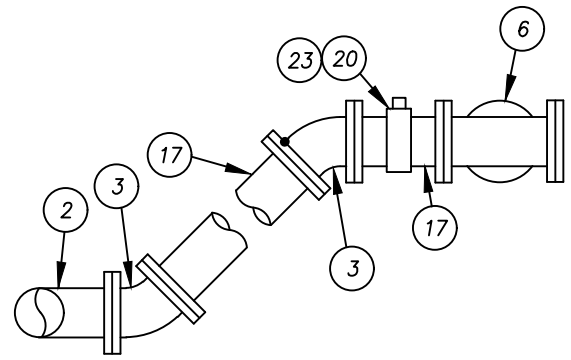

OFFSET PROFILE

PRV LENGTH (IN)	PRV SIZE (IN)	MIN. VAULT DIMENSION			
		A	B	C	L (MIN)
9 3/4	3 (MIN.)	24	36	24	72
15	4	24	36	24	72
20	6	24	36	24	72
25 3/8	8	36	36	36	84
29 3/4	10	36	36	36	84
34	12	36	48	36	96
39	14	36	48	36	96
41 3/8	16	36	48	36	96

A, B & L ARE BASED ON THE LARGER REGULATING VALVE, C IS BASED ON THE SMALLER REGULATING VALVE.
 A+B+C = INSIDE VAULT WIDTH (MIN.)

- ITEM MATERIALS**
- 1 — D.I. 90° BEND, P.O. X F.E.
 - 2 — D.I. 90° BEND, F.E. X F.E.
 - 3 — D.I. 45° BEND, F.E. X F.E.
 - 4 — D.I. SPINDLE, F.E. X G.E., LENGTH AS REQUIRED.
 - 5 — D.I. REDUCER, P.O. X F.E., WHERE REQUIRED.
 - 6 — D.I. TEE, F.E. X F.E.
 - 7 — RW GATE VALVE OR BUTTERFLY VALVE, PER IRWD STD. SPEC. SECTION 15100, F.E. X F.E.
 - 8 — 12" LONG D.I. SPINDLE, F.E. X G.E.
 - 9 — G.E. COUPLING. HEAVY DUTY STYLE 77 WITH STAINLESS STEEL HARDWARE.
 - 10 — PRESSURE REGULATING VALVE PER IRWD STD. SPEC. SECTION 15120 AND PROJECT SPECIFICATIONS. MIN. PRESSURE REGULATING VALVE SIZE SHALL BE 3".
 - 11 — LINK-SEAL MODULAR SEAL MODEL "C" WITH EPDM AND STAINLESS STEEL HARDWARE. SEE IRWD STD. DWG. G-9.
 - 12 — SEAL CORE HOLE OPENING PER IRWD STD. DWG. G-8.
 - 13 — THRUST BLOCK PER IRWD STD DWG. W-16.
 - 14 — D.I. REDUCER, F.E. X F.E.
 - 15 — D.I. 90° BEND, F.E. X F.E.
 - 16 — 12" DIA. AIR VENT AND PIPING PER IRWD STD. SPEC. SECTION 03462 AND PER IRWD STD. DWG. G-7. SEE NOTE 6.
 - 17 — D.I. SPOOL, F.E. X F.E., LENGTH AS REQUIRED.
 - 18 — AWG NO. 8 STRANDED COPPER ANODE LEAD WIRE, PROVIDE AND CONNECT TO SHUNT, LEAVE 36" OF COILED WIRE BEFORE SHUNT IN VAULT. ALUMINO-THERMIC WELD PER IRWD STD. SPEC. SECTION 16640 AND IRWD STD. DWG. CP-8 AND CP-9.
 - 19 — PRECAST CONCRETE VAULT WITH SPRING-ASSIST OPEN HATCH. PROVIDE DIAMOND PLATE ALUMINUM ACCESS DOORS WITH RECESSED PADLOCK HASP FOR #5 LOCK (ON OPPOSITE END OF VAULT FROM LADDER) AND VAULT HATCH CHANNEL DRAIN (PLUMB TO CRUSHED ROCK). SEE TABLE FOR VAULT SIZE. SEE NOTE 2 FOR ADDITIONAL HATCH REQUIREMENTS.
 - 20 — 1" AIR & VACUUM RELEASE PER IRWD STD. DWG. W-11.
 - 21 — LADDER PER IRWD STD. DWG. G-5.
 - 22 — INTRUSION SWITCH. SEE IRWD STD. DWG. W-15 (SHEET 4 OF 15) FOR DETAIL.
 - 23 — 1" SERVICE SADDLE WITH DOUBLE STAINLESS STEEL STRAPS AND NYLON COATED MALLEABLE IRON BODY AND 1" INSULATED BALL CORP OUTLET PER IRWD STD. DWG. W-3. SEE IRWD STD. DWG W-15, SHEET 4 OF 15, FOR TRANSMITTER ASSEMBLY DETAIL.
 - 24 — AWG NO. 8 STRANDED COPPER ANODE LEAD WIRE. CORE DRILL VAULT AND SEAL PER IRWD STD. DWG. G-8.
 - 25 — 20" DIA. VENTED PIPE COVER PER IRWD STD. SPEC. SECTION 15089 AND IRWD STD. DWG. G-7. SEE NOTE 6.
 - 26 — 1" OR 2" COPPER SERVICE PIPE, TYPE "K" RIGID PER IRWD STD. DWG. W-11.
 - 27 — 3M DBI-SALA WALL MOUNTED SLEEVE DAVIT BASE, MODEL #8518348. SEE IRWD STD. DWG. W-15 SHEET 3 OF 15.

NOTES:

1. THIS IS A TEMPLATE — THE ACTUAL SIZES OF THE COMPONENT PRV'S REQUIRED FOR A SPECIFIC LOCATION NEED TO BE SHOWN ON THE PLAN ALONG WITH THEIR SETTINGS.
2. WHERE VAULTS ARE CONSTRUCTED WITHIN ANY VEHICLE TRAVEL LANE, ACCESS HATCHES SHALL BE STAINLESS STEEL AND RATED FOR CONTINUOUS H-20 TRAFFIC LOADING.
3. VAULTS SHALL BE CONSTRUCTED A MIN. OF 24" AWAY FROM CURB OR SIDEWALK LEVEL, AND DESIGNED BY THE ENGINEER OF RECORD TO ACCOUNT FOR NUISANCE WATER AND THE SAFETY OF THE TRAVELING PUBLIC.
4. AT NO POINT SHALL ANY PART OF THE PRESSURE REGULATING STATION BE CLOSER THAN 36" AWAY FROM ANY STRUCTURE OR LANDSCAPING.
5. PIPING FOR 3" PRV ASSEMBLIES SHALL BE 4" DIA. PROVIDE 3"x4" REDUCED AT PRV.
6. VENTED PIPE COVERS SHALL BE FROM SAME MANUFACTURER WITH MATCHING INTEGRAL COLOR PER IRWD. STD. SPEC. SECTION 15089.

PRESSURE REGULATING STATION (PRV)

IRVINE RANCH WATER DISTRICT, ENGINEERING DEPARTMENT
 APPROVED BY:

 KEVIN L. BURTON R.M.E. M28832
 EXECUTIVE DIRECTOR, TECHNICAL SERVICES

FEBRUARY 2025
 REVISION

**IRWD
 STD. DWG.
 W-15**

NOT TO SCALE
 SHEET 1 OF 15

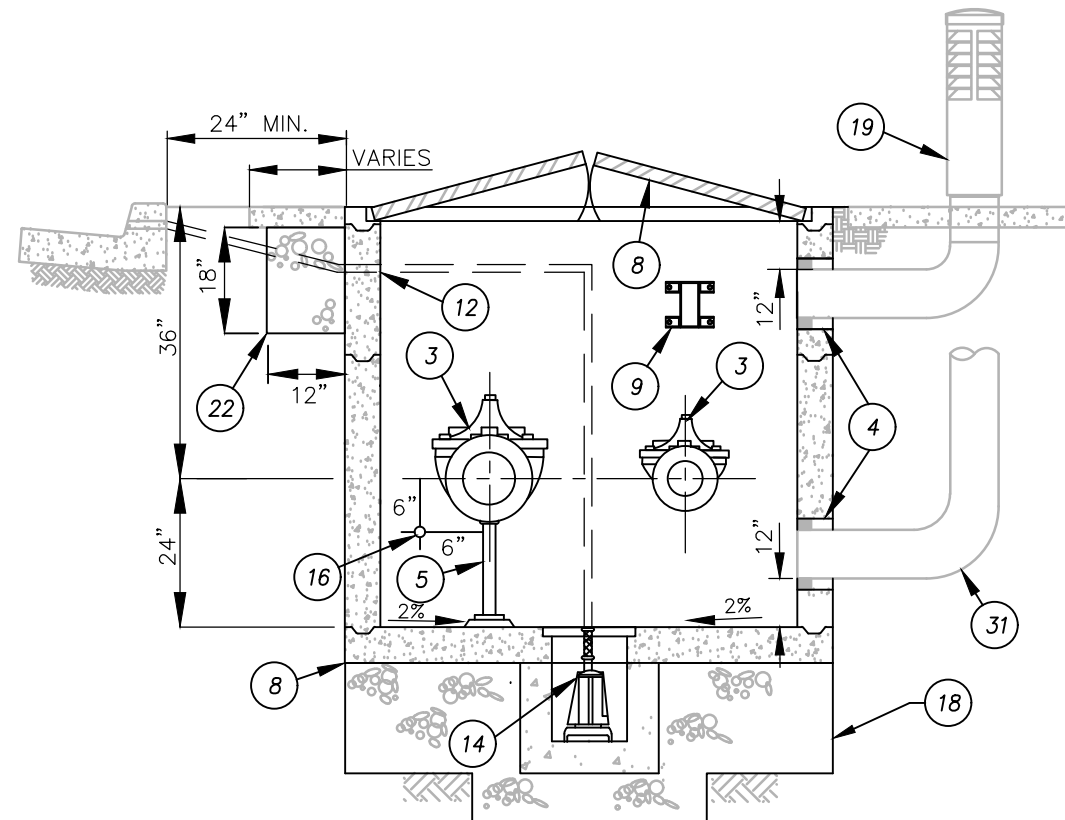

SECTION B-B

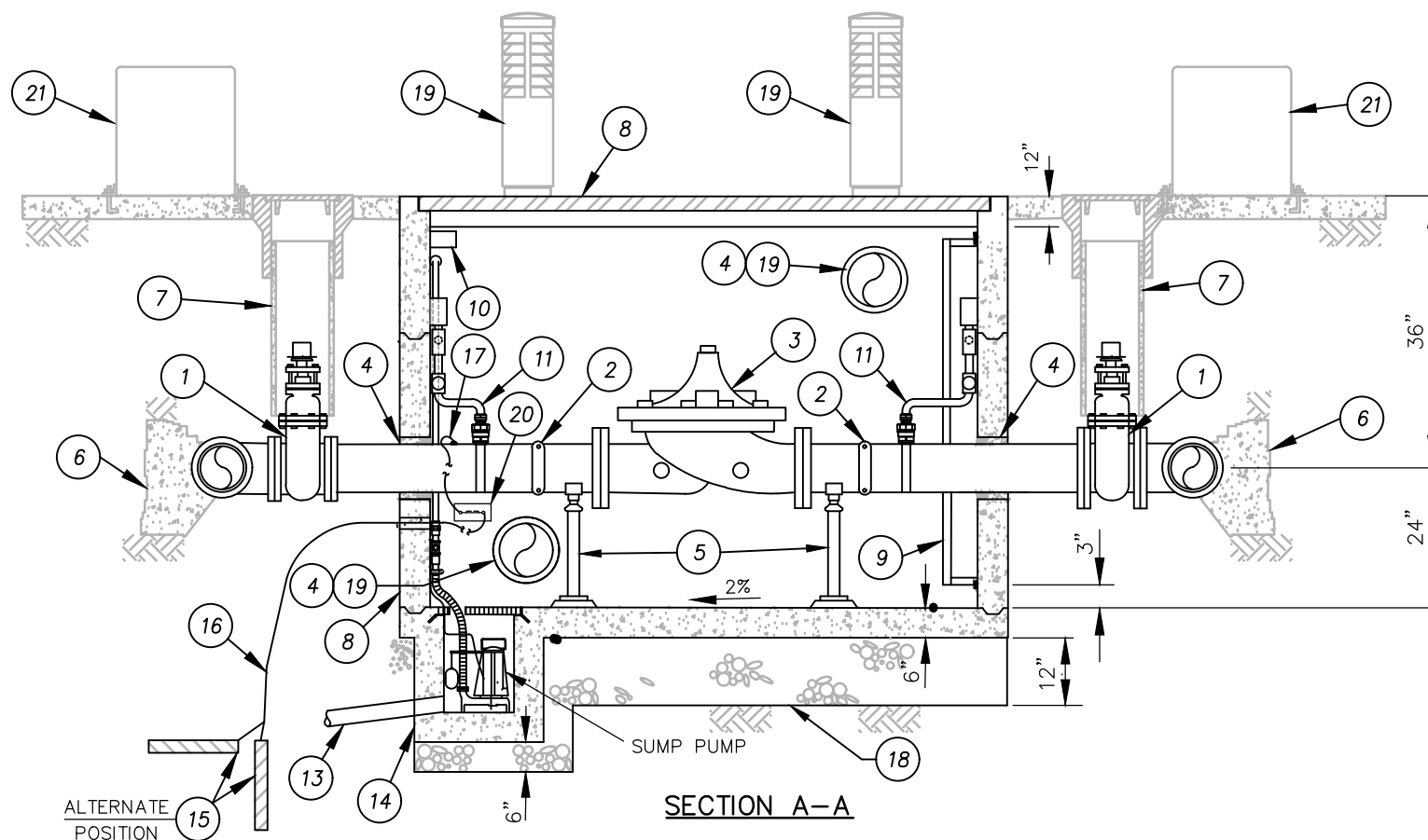

SECTION A-A

ITEM MATERIALS

- 1 — RW GATE VALVE OR BUTTERFLY VALVE, PER IRWD STD. SPEC. SECTION 15100, F.E. X F.E.
- 2 — G.E. COUPLING, HEAVY DUTY STYLE 77 WITH STAINLESS STEEL HARDWARE.
- 3 — PRESSURE REGULATING VALVE PER IRWD STD. SPEC. SECTION 15120 AND PROJECT SPECIFICATIONS. MIN. PRESSURE REGULATING VALVE SIZE SHALL BE 3".
- 4 — LINK-SEAL MODULAR SEAL MODEL "C" WITH EPDM AND STAINLESS STEEL HARDWARE. SEE IRWD STD. DWG. G-9.
- 5 — PIPE SUPPORT PER IRWD STD. DWG. W-24.
- 6 — THRUST BLOCK PER IRWD STD. DWG. W-16.
- 7 — VALVE BOX PER IRWD STD. DWG. W-22.
- 8 — PRECAST CONCRETE VAULT WITH SPRING-ASSIST OPEN HATCH. PROVIDE DIAMOND PLATE ALUMINUM ACCESS DOORS WITH RECESSED PADLOCK HASP FOR #5 LOCK (ON OPPOSITE END OF VAULT FROM LADDER) AND VAULT HATCH CHANNEL DRAIN (PLUMB TO CRUSHED ROCK). SEE TABLE ON SHEET 1 OF 15 FOR VAULT SIZE. SEE NOTE 1 FOR ADDITIONAL HATCH REQUIREMENTS.
- 9 — 3M DBI-SALA WALL MOUNTED SLEEVE DAVIT BASE, MODEL #8518348. SEE IRWD STD. DWG. W-15 SHEET 3 OF 15.
- 10 — INTRUSION SWITCH. SEE IRWD STD. DWG. W-15 (SHEET 4 OF 15) FOR DETAIL.
- 11 — 1" SERVICE SADDLE WITH DOUBLE STAINLESS STEEL STRAPS AND NYLON COATED MALLEABLE IRON BODY AND 1" BALL CORP OUTLET PER IRWD STD. DWG. W-3. SEE IRWD STD. DWG. W-15 SHEET 4 OF 15 FOR TRANSMITTER ASSEMBLY.
- 12 — SEAL CORE HOLE PER IRWD STD. DWG. G-8.
- 13 — 4" SCH 80 PVC DRAIN PIPE OR SUMP PUMP (FOR DOMESTIC WATER APPLICATIONS ONLY), SEE IRWD STD. DWG. G-6.
- 14 — VAULT SUMP PER IRWD STD. DWG. G-6.
- 15 — 60 POUND ZINC ANODE AND LEAD WIRE. ANODE TO BE PLACED VERTICALLY OR HORIZONTALLY AT A MIN. SEPARATION OF 24" FROM THE PIPING.
- 16 — AWG NO. 8 STRANDED COPPER ANODE LEAD WIRE. CORE DRILL VAULT AND SEAL PER IRWD STD. DWG. G-8.
- 17 — AWG NO 8 STRANDED COPPER ANODE LEAD WIRE, PROVIDE AND CONNECT TO SHUNT, LEAVE 36" OF COILED WIRE BEFORE SHUNT IN VAULT. ALUMINO-THERMIC WELD PER IRWD STD. SPEC. SECTION 16640 AND IRWD STD. DWG. CP-8 AND CP-9.
- 18 — 3/4" CRUSHED ROCK.
- 19 — 12" DIA. AIR VENT AND PIPING PER IRWD STD. SPEC. SECTION 03462 AND PER IRWD STD. DWG. G-7.
- 20 — BRASS SHUNT WITH PLASTIC BASE, BY FARWEST CORROSION OR MESA PRODUCTS. MOUNT SHUNT TO WALL WITH 4" RED HEAD 316 SS ANCHORS. LEAVE 36" OF COILED WIRE ON EACH SIDE OF SHUNT.
- 21 — AIR & VACUUM RELEASE COVER PER IRWD STD. DWG. W-11. SEE NOTE 2.
- 22 — 18" OF 3/4" CRUSHED ROCK FOR CHANNEL DRAIN.

NOTES:

1. WHERE VAULTS ARE CONSTRUCTED WITHIN ANY VEHICLE TRAVEL LANE, ACCESS HATCHES SHALL BE STAINLESS STEEL AND RATED FOR CONTINUOUS H-20 TRAFFIC LOADING.
2. INSTALL IRWD LOGO DECAL "DOMESTIC" OR "RECYCLED" AS DIRECTED BY IRWD.
3. STENCIL "DOMESTIC" OR "RECYCLED" ON WHITE BACKING WITH BLACK 4" HIGH LETTERING INSIDE VAULT AT 12" BELOW BOTTOM OF HATCH OPENING. PROVIDE STENCIL IN TWO LOCATIONS ON OPPOSITE WALLS.
4. WHERE VAULTS ARE OFFSET FROM CURB OR SIDEWALK, OR PLACED IN PARKWAYS, SET HATCH 2" ABOVE FINISHED SURFACE.

PRESSURE REGULATING STATION (PRV)

IRVINE RANCH WATER DISTRICT, ENGINEERING DEPARTMENT

APPROVED BY:

Kevin L. Burton

KEVIN L. BURTON R.M.E. M28832
EXECUTIVE DIRECTOR, TECHNICAL SERVICES

FEBRUARY 2025
REVISION



IRWD
STD. DWG.
W-15

NOT TO SCALE
SHEET 2 OF 15

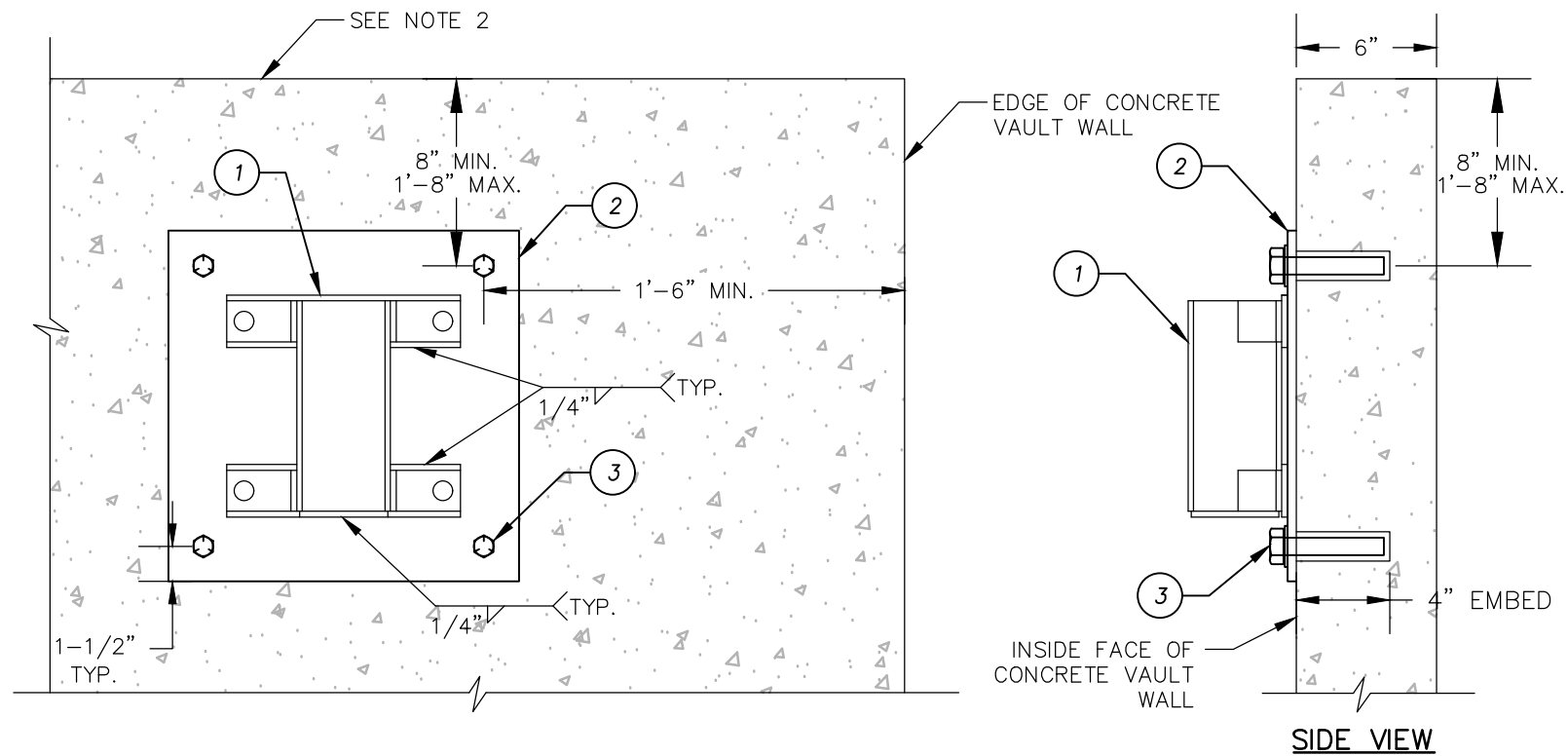

**WALL MOUNTED SLEEVE DAVIT BASE ANCHORING DETAIL
6" THICK VAULT WALL**

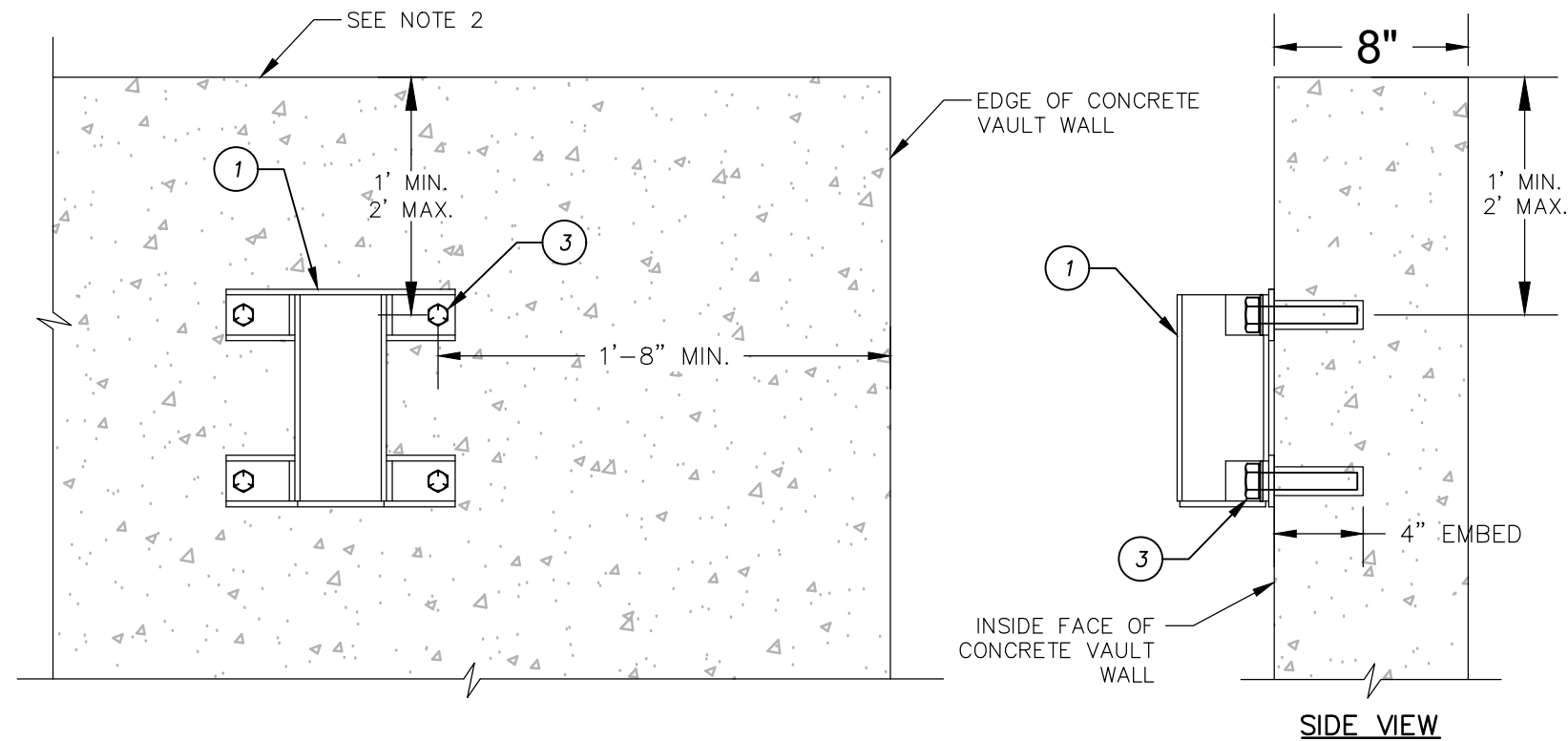

**WALL MOUNTED SLEEVE DAVIT BASE ANCHORING DETAIL
8" THICK VAULT WALL AND LARGER**

ITEM	MATERIALS
1	3M DBI-SALA WALL MOUNTED SLEEVE DAVIT BASE, MODEL #8518348.
2	15" X 15" 316 STAINLESS STEEL MOUNTING PLATE, 1/2" THICK. CENTER SLEEVE DAVIT BASE.
3	3/4" STAINLESS STEEL ADHESIVE ANCHORS, EMBED 4" INTO VAULT WALL. HILTY-HY 200, SIMPSON AT-XP, OR EQUAL.

NOTES:

- 15" X 15" STAINLESS STEEL MOUNTING PLATE REQUIRED FOR VAULTS WITH 6" THICK WALLS. MOUNTING PLATE SHALL BE OMITTED WHEN VAULT WALLS ARE 8" THICK OR LARGER AND THE SLEEVE DAVIT BASE SHALL BE MOUNTED DIRECTLY TO THE VAULT WALL.
- MOUNTING PLATE OR SLEEVE DAVIT BASE SHALL BE MOUNTED ACCORDING TO THE MINIMUM DIMENSIONS SHOWN FROM ANY OF THE FOLLOWING CONDITIONS WITHIN THE VAULT: BOTTOM OF VAULT HATCH LIDS, TOP OF VAULT WALL, AND HORIZONTAL WALL JOINT, WHICHEVER IS CLOSEST TO THE INSTALLATION.
- SLEEVE DAVIT BASE SHALL NOT BE LOCATED ABOVE SUMP PUMP.
- COORDINATE FINAL LOCATION OF SLEEVE DAVIT BASE WITH DISTRICT REPRESENTATIVE PRIOR TO MOUNTING TO VAULT WALL.

PRESSURE REGULATING STATION (PRV)

IRVINE RANCH WATER DISTRICT, ENGINEERING DEPARTMENT
 APPROVED BY:

 KEVIN L. BURTON R.M.E. M28832
 EXECUTIVE DIRECTOR, TECHNICAL SERVICES

FEBRUARY 2025
 REVISION

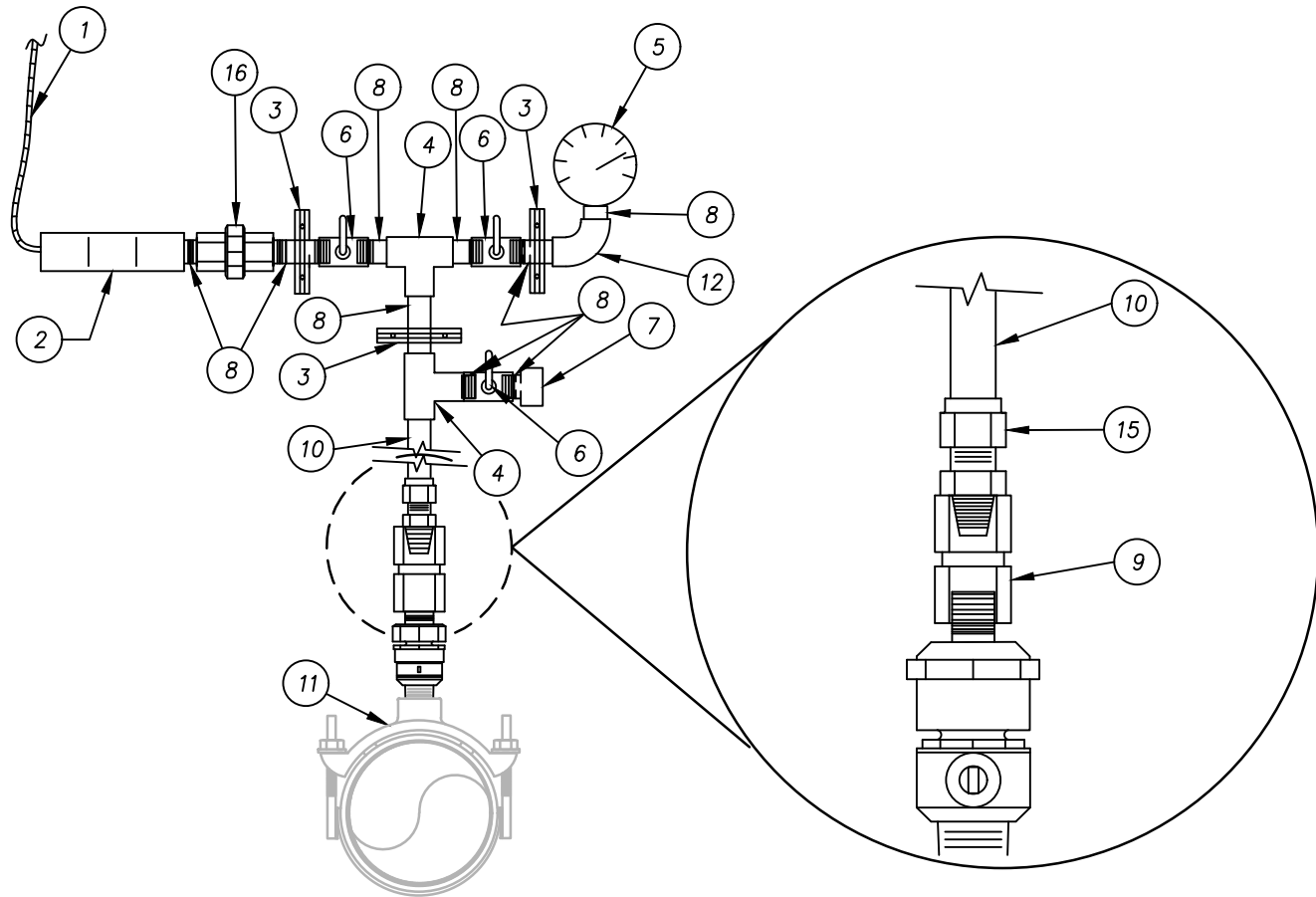

**IRWD
 STD. DWG.
 W-15**
 NOT TO SCALE
 SHEET 3 OF 15



TRANSMITTER ASSEMBLY DETAIL

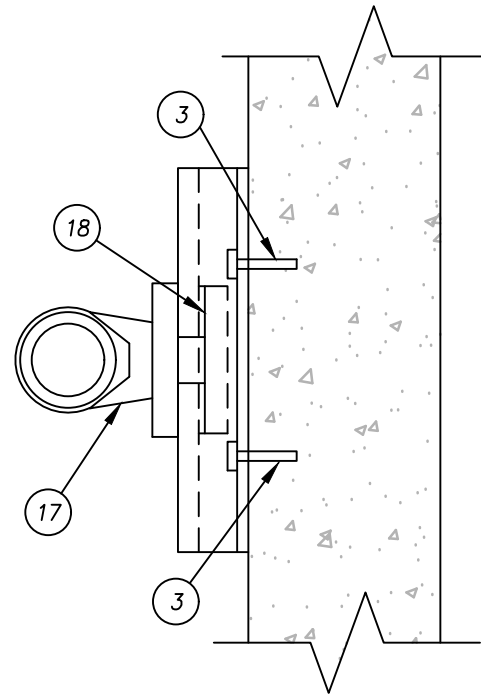

SIDE VIEW

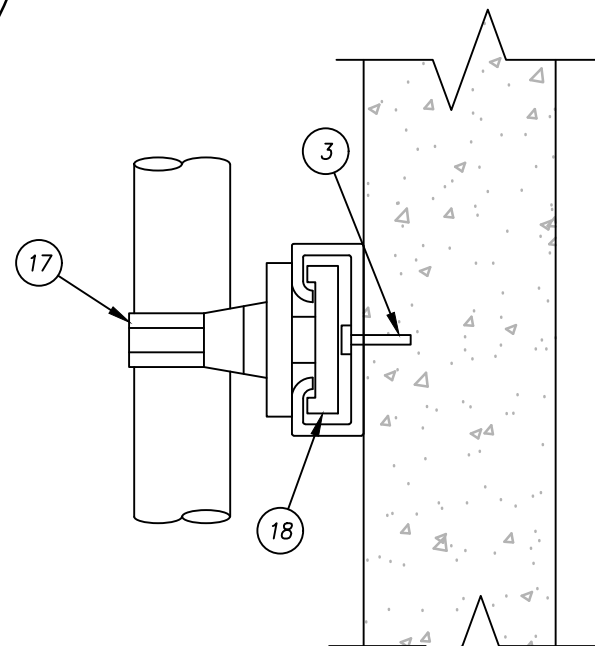

TOP VIEW

TYPICAL BRACKET

- | ITEM | MATERIALS |
|------|--|
| 1 | FLEXIBLE WATER TIGHT CONDUIT. |
| 2 | PRESSURE TRANSMITTER, 4-20 mA, PER IRWD STD. SPEC. SECTION 17200. |
| 3 | MOUNT TO WALL WITH STAINLESS STEEL STRUT CHANNEL AND HARDWARE. USE 3/8" P4000SS 2" RED HEAD ANCHORS. |
| 4 | 3/8" X 3/8" STAINLESS STEEL THREADED TEE, F.I.P.T. |
| 5 | PRESSURE GAUGE, PER IRWD STD. SPEC. SECTION 17200. |
| 6 | 3/8" STAINLESS STEEL BALL VALVE, WITH LEVER HANDLE F.I.P.T. BOTH ENDS. |
| 7 | 3/8" STAINLESS STEEL THREADED CAP, F.I.P.T. |
| 8 | 3/8" STAINLESS STEEL CLOSE NIPPLE, M.I.P.T. |
| 9 | 1" X 3/8" STAINLESS STEEL THREADED REDUCER BUSHING, F.I.P.T. BOTH ENDS. |
| 10 | 3/8" STAINLESS STEEL FLEX TUBING WITH COMPRESSION ADAPTER FITTINGS ON EACH END. |
| 11 | 1" SERVICE SADDLE WITH DOUBLE STAINLESS STEEL STRAPS AND NYLON COATED MALLEABLE IRON BODY AND 1" INSULATED BALL CORP WITH F.I.P.T. OUTLET, SEE IRWD STD. DWG. W-3. |
| 12 | 3/8" STAINLESS STEEL THREADED 90° BEND, F.I.P.T. |
| 13 | ELECTRO-MECHANICAL LIMIT SWITCH FOR INTRUSION ALARM. |
| 14 | 1/8" ALUMINUM PLATE FOR MOUNTING INTRUSION SWITCH. |
| 15 | 3/8" STAINLESS STEEL MALE CONNECTOR, M.I.P.T. X TUBE. |
| 16 | 3/8" STAINLESS STEEL THREADED COUPLING. |
| 17 | 3/8" PLASTIC PIPE HANGER CLIP (CLIC SYSTEM OR EQUAL). |
| 18 | P4000SS UNI-STRUT CHANNEL HARDWARE FOR ANCHORING CLIP TO CHANNEL. |

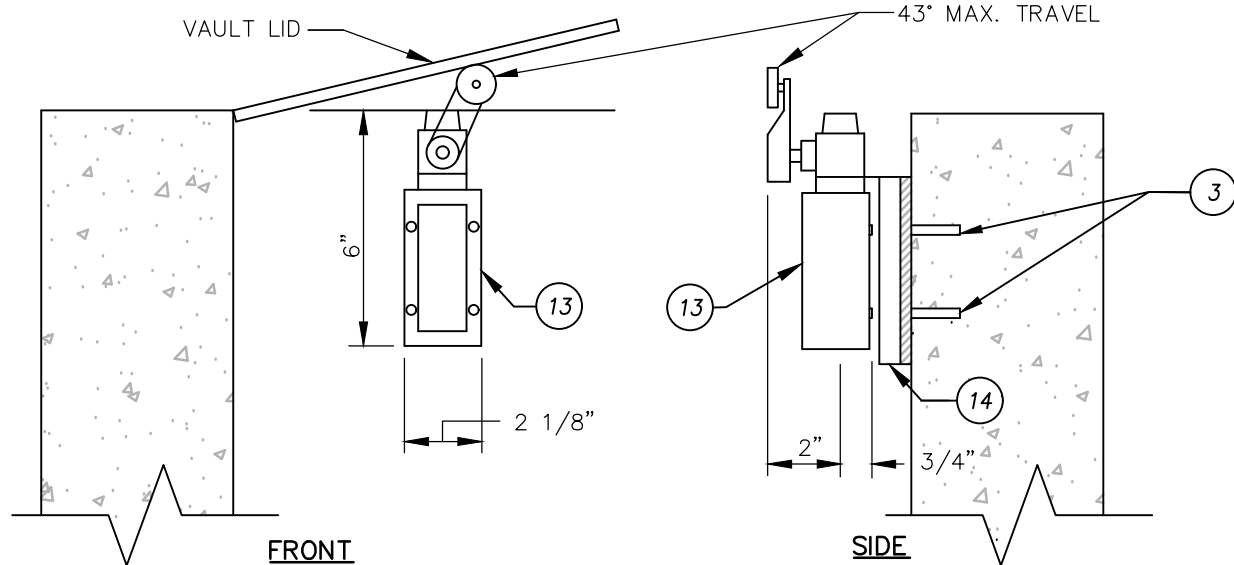

INTRUSION SWITCH

PRESSURE REGULATING STATION (PRV)

IRVINE RANCH WATER DISTRICT, ENGINEERING DEPARTMENT

APPROVED BY:

Kevin L. Burton
 KEVIN L. BURTON R.M.E. M28832
 EXECUTIVE DIRECTOR, TECHNICAL SERVICES

FEBRUARY 2025
 REVISION



**IRWD
 STD. DWG.
 W-15**

NOT TO SCALE
 SHEET 4 OF 15

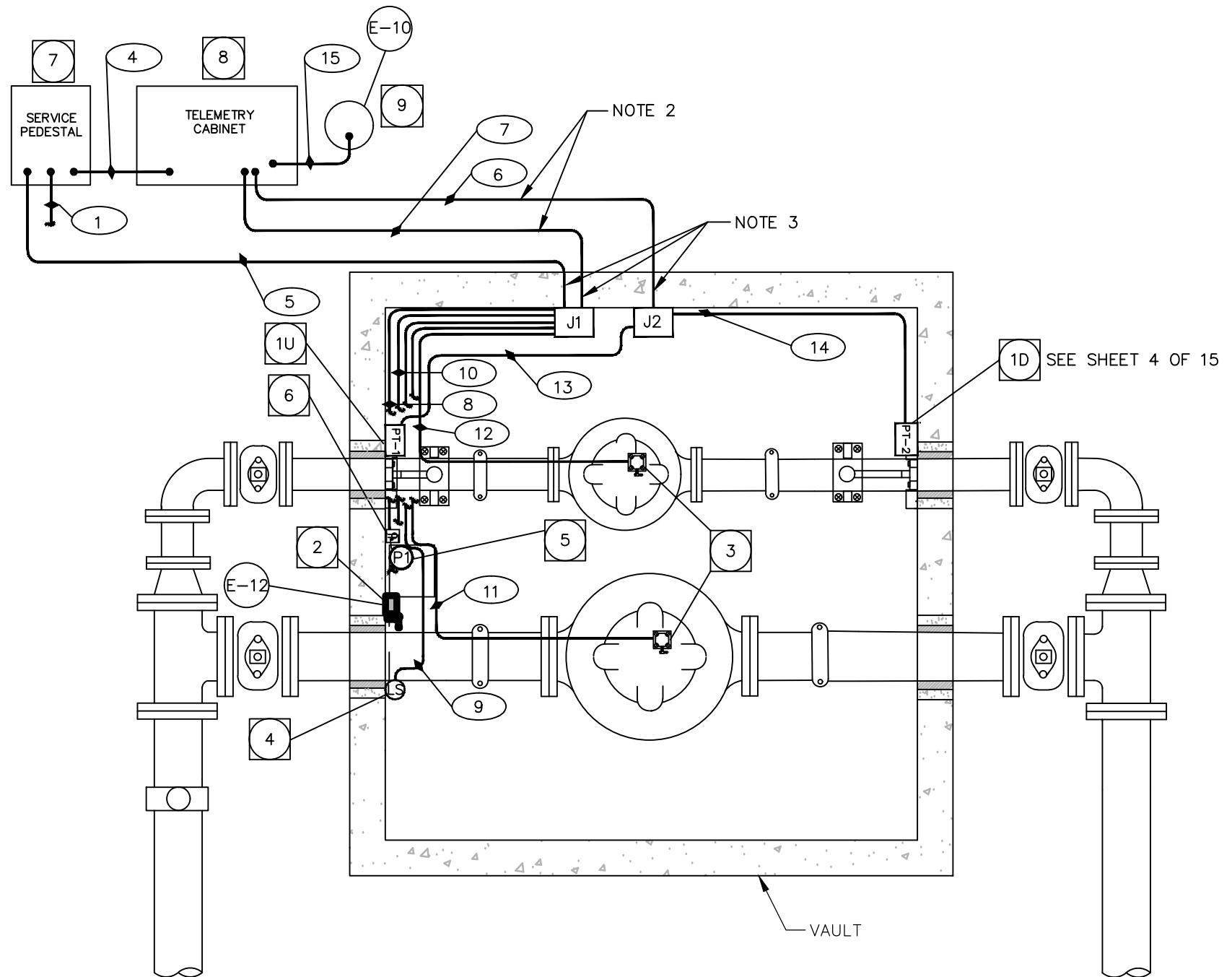

NOTES:

1. INSTALL CONDUIT SO THERE IS NO INTERFERENCE WITH UNDERLYING PIPING, VALVES, OR APPURTENANCES.
2. LOCATE SERVICE PEDESTAL AND TELEMETRY CABINET AS REQUIRED. TYPICAL LOCATIONS SHOWN.
3. SEAL CORE HOLE OPENING PER IRWD STD. DWG. G-8.

LEGEND:

- CONDUIT NO. SEE CONDUIT SCHEDULE ON IRWD STD. DWG. W-15 (E-3) SHEET 7 OF 15.
- ITEM NO. SEE MATERIAL LIST ON IRWD STD. DWG. W-15 (E-3) SHEET 7 OF 15.
- IRWD STD. DWG. W-15 ELECTRICAL DRAWING (E-#) SHEET NUMBER.

PRESSURE REGULATING STATION ELECTRICAL-CONDUIT PLAN (VAULT #1)

PRESSURE REGULATING STATION (PRV)

IRVINE RANCH WATER DISTRICT, ENGINEERING DEPARTMENT

APPROVED BY:

Kevin L. Burton
 KEVIN L. BURTON R.M.E. M28832
 EXECUTIVE DIRECTOR, TECHNICAL SERVICES

FEBRUARY 2025
 REVISION



**IRWD
 STD. DWG.
 W-15 (E-1)**
 NOT TO SCALE
 SHEET 5 OF 15

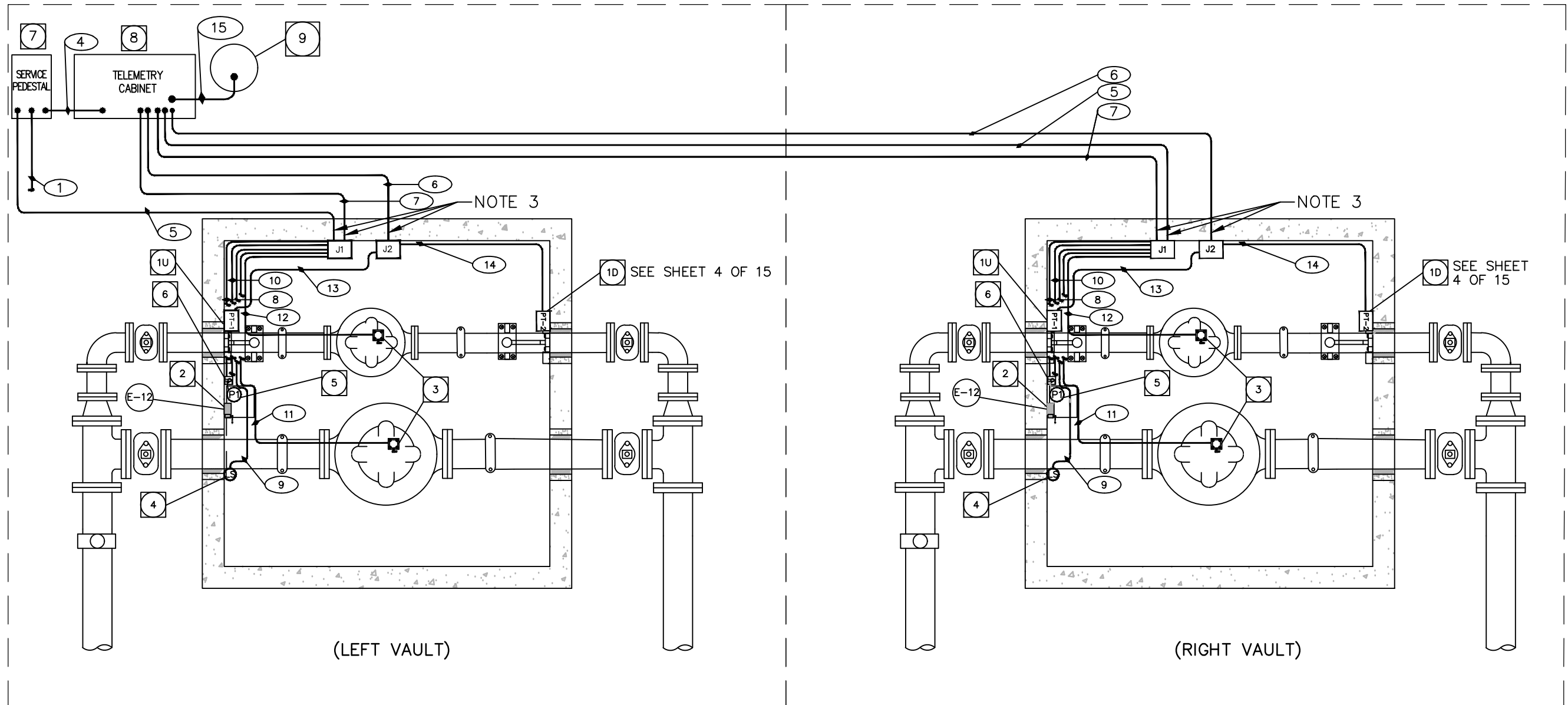

NOTES:

1. THIS SHEET APPLIES TO DUAL PRV CONFIGURATIONS. "LEFT" AND "RIGHT" DESIGNATIONS ARE DERIVED FROM YOU FACING THE FRONT OF THE "TELEMETRY CABINET".
2. LOCATE SERVICE PEDESTAL AND TELEMETRY CABINET AS REQUIRED. TYPICAL LOCATIONS SHOWN.
3. SEAL CORE HOLE OPENING PER IRWD STD. DWG. G-8 OR G-9.

LEGEND:

- CONDUIT NO. SEE CONDUIT SCHEDULE ON IRWD STD. DWG. W-15 (E-3) SHEET 7 OF 15.
- ITEM NO. SEE MATERIAL LIST ON IRWD STD. DWG. W-15 (E-3) SHEET 7 OF 15.
- IRWD STD. DWG. W-15 ELECTRICAL DRAWING (E-#) SHEET NUMBER.

PRESSURE REGULATING STATION (PRV)

IRVINE RANCH WATER DISTRICT, ENGINEERING DEPARTMENT

APPROVED BY:

Kevin L. Burton
 KEVIN L. BURTON R.M.E. M28832
 EXECUTIVE DIRECTOR, TECHNICAL SERVICES

FEBRUARY 2025
 REVISION



**IRWD
 STD. DWG.
 W-15 (E-2)**

NOT TO SCALE
 SHEET 6 OF 15

ELECTRICAL COMPONENTS MATERIAL LIST

ITEM	QTY.	DEVICE ID.	DESCRIPTION	MANUFACTURER	MODEL NUMBER	SUBSTITUTIONS	RANGE	REMARKS
1U	1	PT-10	PRESSURE TRANSMITTER	AMETEK	575S	NOT ALLOWED	0-250 PSI	CABLE TO BE UNSPLICED TO TELEMETRY CAB.
				DRUCK	PTX-530-8839		0-250 PSI	
				KELLER PSI	730-142-00250		0-250 PSI	
1D	1	PT-20	PRESSURE TRANSMITTER	AMETEK	575S	NOT ALLOWED	0-150 PSI	
				DRUCK	PTX-530-8839		0-150 PSI	
				KELLER PSI	730-142-00150		0-150 PSI	
2	1	ZS-10	HATCH ENTRY SWITCH	ALLEN BRADLEY	802-T-AP	NOT ALLOWED		NORMALLY OPEN
	1		ROLLER ARM FOR HATCH SW.	ALLEN BRADLEY	802T-W2B	NOT ALLOWED		
3	2	ZS-20 & 3	STEM POS. SW. (HELD CLOSED)	N\A	N\A	NOT ALLOWED		NORMALLY OPEN\ SUPPLIED W\ VALVE
4	1	LS-10	VAULT FLOODED SWITCH	ANCHOR SCIENTIFIC	ROTO-FLOAT MODEL S, NONC	NOT ALLOWED		NORMALLY CLOSED
5	1	P-1	SUMP PUMP	ZOELLER	GRAINGER CAT. #2P550	NOT ALLOWED		INSTALL ITEM 6 ON FACTORY SUPPLIED CORD
6	1	N\A	WEATHER PROOF OUTLET AND PLUG	DANIEL WOODHEAD	PLUG 14W47 RECPT. 60W47	NOT ALLOWED		
7	1	N\A	SERVICE AND METERING CABINET	MEYERS	MEUG16A - M100	ALLOWED		120 / 240 V, 100A
8	1	N\A	TELEMETRY CABINET	APX ENCLOSURES, INC.	TC512516 SS	ALLOWED		SEE SHT. 9 OF 15 (E-5)
9	1	N\A	POLE WITH ANTENNA	U.S. POLE	35-11	NOT ALLOWED		SEE SHT. 14 OF 15 (E-10)

CONDUIT SCHEDULE

SYMBOL	CONDUIT		WIRE	DESCRIPTION	LOCATION		REMARKS	
	NO.	QTY.	SIZE		QTY.	SIZE		USE
1	1	3"	2#2&1#12 GND		POWER	SCE SOURCE	SERVICE PEDSTAL	120/240VAC SERVICE FEED
2								NOT USED
3								NOT USED
4	1	1"	5#12&2#12 GND		POWER	SERVICE PED.	TELEMTRY CABINET	CONTROL POWER
5	1	1"	2#12&1#12 GND		POWER	SERVICE PED.	PULL BOX J1	SUMP PUMP POWER
6	1	1"	2 TRANSDUCER CABLES		INSTRUMENT	TELEMETRY CAB.	PULL BOX J2	FOR PT-10, PT-20
7	1	1"	8#14&1#12 GND		CONTROL	TELEMETRY CAB.	PULL BOX J1	FOR ZS-10, ZS-20, ZS-3, LS-10
8	1	3/4"	2#12&1#12 GND		POWER	PULL BOX J1	SUMP PUMP OUTLET	DEDICATED CIRCUIT FROM SVS. PED
9	1	3/4"	2#14&1#14 GND		CONTROL	PULL BOX J1	LS-10	VAULT FLOODED SWITCH
10	1	3/4"	2#14&1#14 GND		CONTROL	PULL BOX J1	ZS-3	INTRUSION SWITCH
11	1	3/4"	2#14&1#14 GND		CONTROL	PULL BOX J1	ZS-10	VALVE POSITION SWITCH
12	1	3/4"	2#14&1#14 GND		CONTROL	PULL BOX J1	ZS-20	VALVE POSITION SWITCH
13	1	3/4"	TRANSDUCER CABLE		INSTRUMENT	PULL BOX J2	PT-10	UPSTREAM PRESS. TRANSDUCER
14	1	3/4"	TRANSDUCER CABLE		INSTRUMENT	PULL BOX J2	PT-20	DOWNSTREAM PRESS. TRANSDUCER
15	1	2"	COAX		ANTENNA CABLE	ANTENNA	TELEMETRY CABINET	LMR-400 COAX

PRESSURE REGULATING STATION (PRV)

IRVINE RANCH WATER DISTRICT, ENGINEERING DEPARTMENT
 APPROVED BY:

 KEVIN L. BURTON R.M.E. M28832
 EXECUTIVE DIRECTOR, TECHNICAL SERVICES

FEBRUARY 2025
 REVISION

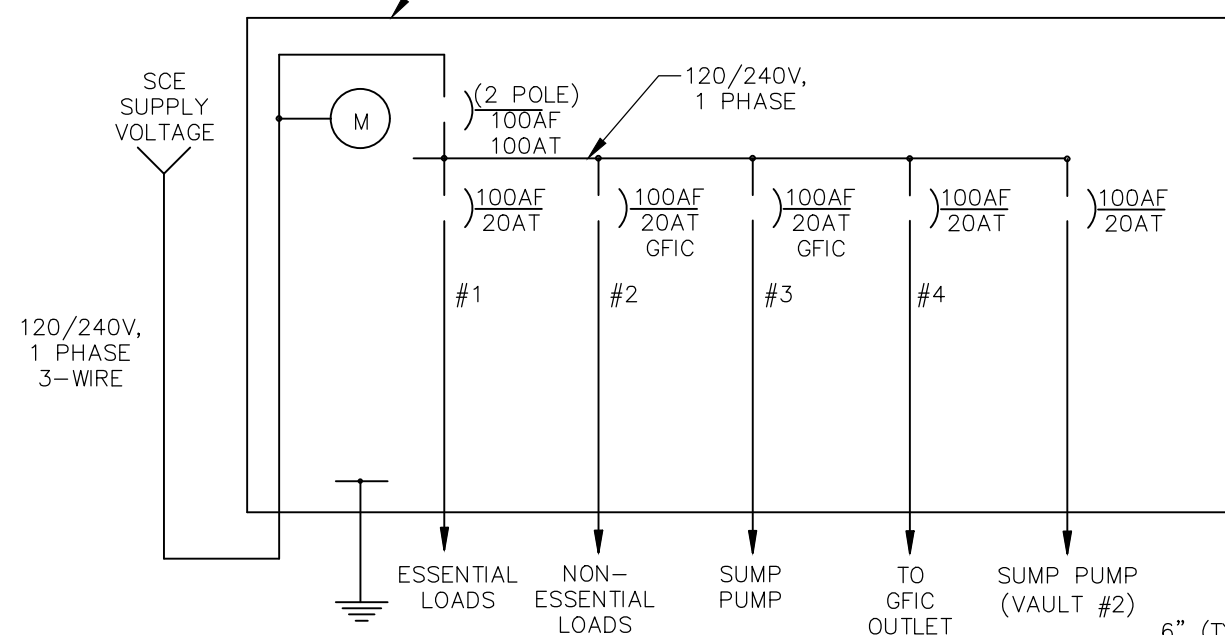

**IRWD
 STD. DWG.
 W-15 (E-3)**
 NOT TO SCALE
 SHEET 7 OF 15

SEE SITE PLAN OR CONTACT SCE SERVICE PLANNER FOR LOCATION OF POWER SERVICES



SINGLE LINE DIAGRAM

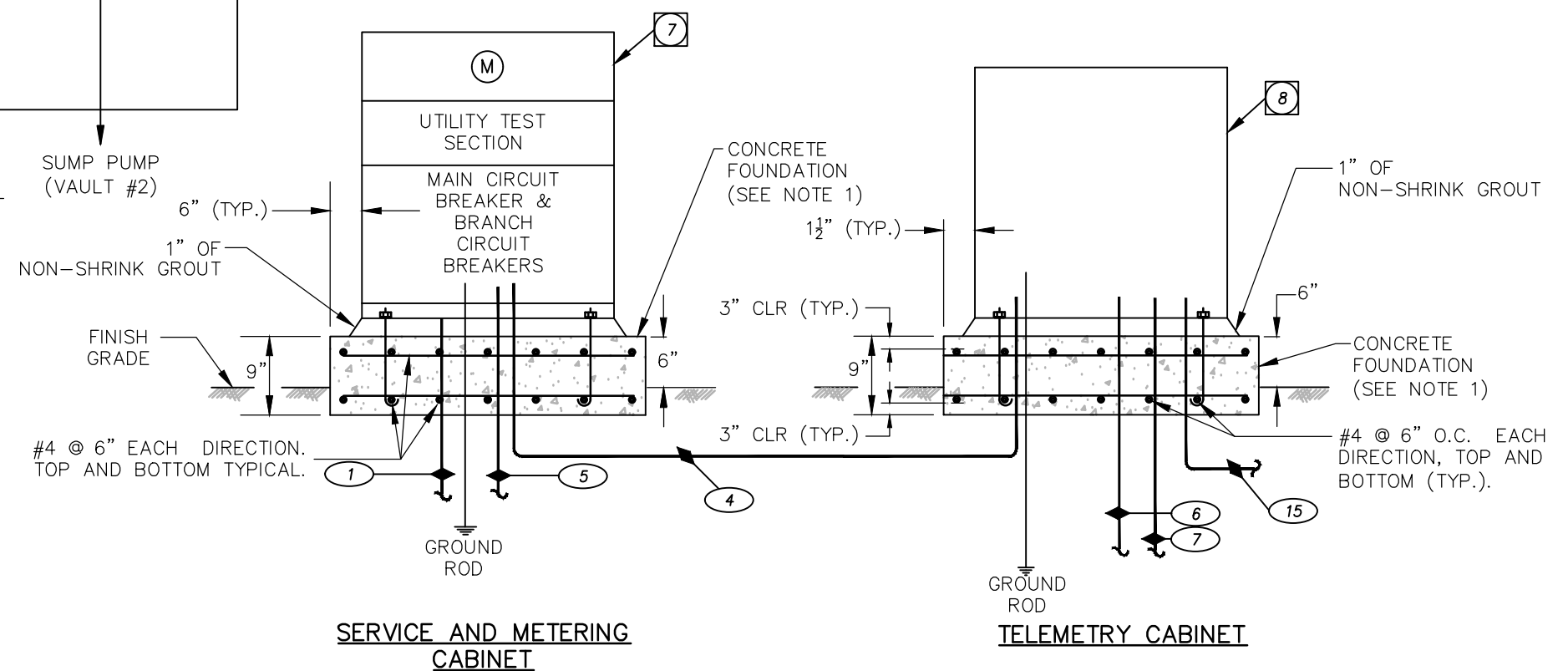

SERVICE AND METERING CABINET

TELEMETRY CABINET

CABINET ELEVATIONS

NOTES:

1. CONCRETE CABINET FOUNDATION (AT IRWD DISCRETION) MAY BE POURED AS A SINGLE PAD. IN THAT EVENT, CABINETS SHALL BE SPACED 9" APART MIN.
2. REFER TO CONDUIT AND ELECTRICAL COMPONENT SCHEDULES ON IRWD STD. DWG. W-15 (E-3), SHEET 7 OF 15.
3. CONDUIT PENETRATIONS THROUGH SLAB AND IN AND OUT OF CABINETS SHALL BE PVC LINED AND COATED OCAL PER IRWD STD. SPEC. SECTION 16110.

PRESSURE REGULATING STATION (PRV)		
IRVINE RANCH WATER DISTRICT, ENGINEERING DEPARTMENT		
APPROVED BY: 		
KEVIN L. BURTON R.M.E. M28832 EXECUTIVE DIRECTOR, TECHNICAL SERVICES	FEBRUARY 2025 REVISION	IRWD STD. DWG. W-15 (E-4) NOT TO SCALE SHEET 8 OF 15

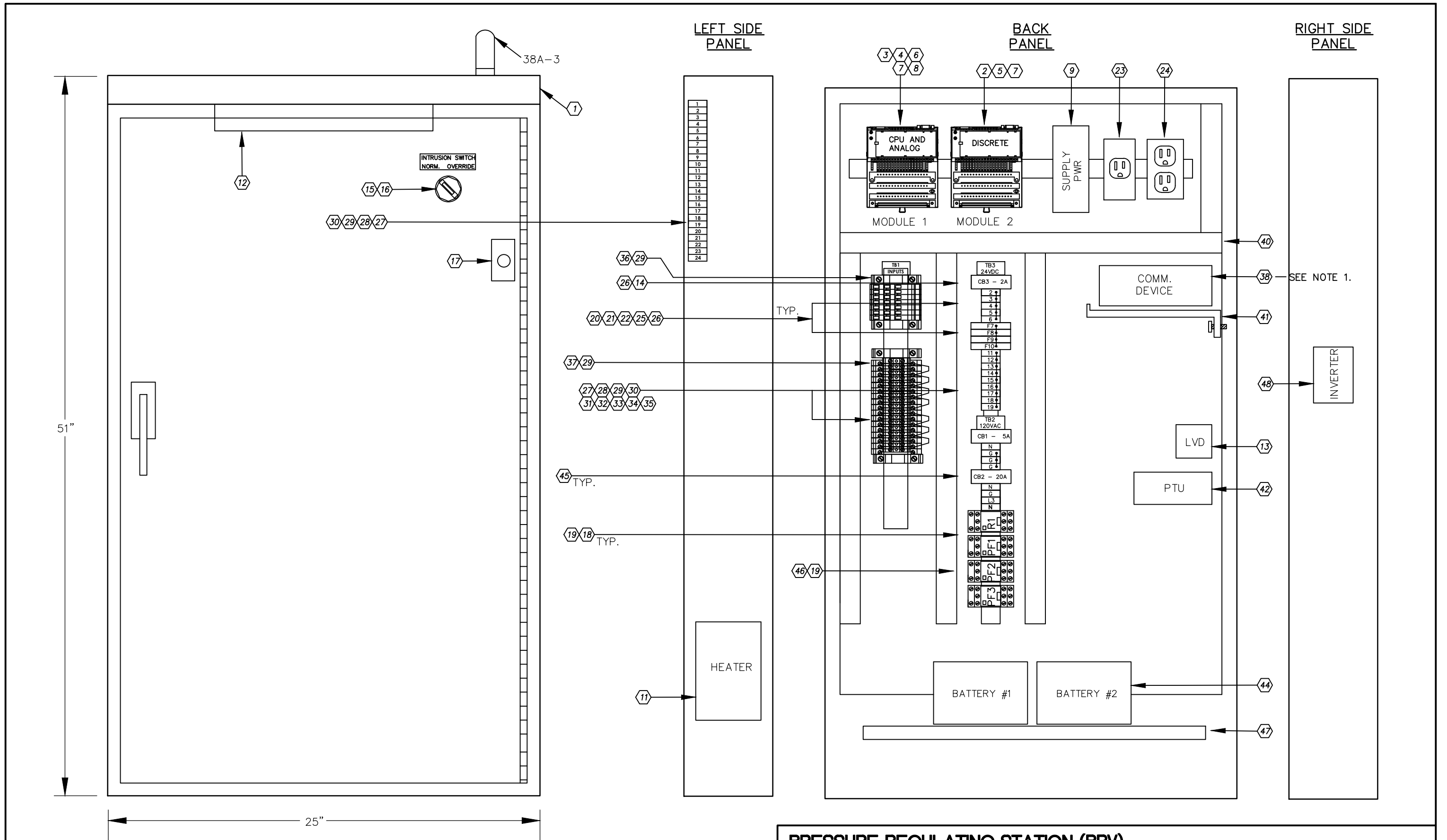

NOTE:

1. PROVIDE ITEM 38A OR 38B PER IRWD ELECTRICAL ENGINEERING REPRESENTATIVE OR PROJECT DRAWINGS/SPECIFICATIONS.

TELEMETRY CABINET DETAILS

PRESSURE REGULATING STATION (PRV)

IRVINE RANCH WATER DISTRICT, ENGINEERING DEPARTMENT

APPROVED BY:

Kevin L. Burton

KEVIN L. BURTON R.M.E. M28832
EXECUTIVE DIRECTOR, TECHNICAL SERVICES

FEBRUARY 2025
REVISION



**IRWD
STD. DWG.
W-15 (E-5)**

NOT TO SCALE
SHEET 9 OF 15

MATERIAL LIST

ITEM	DESCRIPTION	MANUFACTURER	PART NUMBER	QTY
1	NEMA 4X Enclosure	APX Enclosures	TLCS-512516	1
	WITH BACK PANEL	APX Enclosures	TLCS-512516	1
	WITH SWING OUT PANEL	APX Enclosures	TLCS-512516	1
2	Modican Momentum PLC Discrete I/O Base	Square D	170ADM35010	1
3	Modican Momentum PLC Analog I/O Base	Square D	170AAI03000	1
4	Modican Momentum PLC M1 Ethernet Card	Square D	171CCC96030	1
5	Modican Momentum PLC Interbus Comm. Adapter	Square D	171INT11000	1
6	Modican Momentum PLC Cm Interbus Cable	Square D	170MCI00700	1
7	Modican Momentum PLC 800 I/O Module	Square D	170XTS00100	3
8	Modican Momentum PLC Mb Option Adapter	Square D	170JNN21032	1
9	Power Supply Quint 24V/2.5A 24VDC-28VDC	Phoenix	2938578	1
10	1000VA UPS	Powerware	PW115-1000	0
11	Electric Heater	Hoffman	DAH4001B	1
12	Light Fixture	Hoffman	A-LF16M18R	1
13	Circuit Breaker 1P 20Amp	Allen-Bradley	1492-GB1G200	1
14	Circuit Breaker 1P 2Amp	Allen-Bradley	1492-GB1G020	1
15	Key Switch	Cutter-Hammer	10250T15113	1
16	Contact Block for Item 15	Cutter-Hammer	10250T1H	1
17	Intrusion Switch	Cutter-Hammer	10316H2042	1
18	Relay	Idec	RR2PULAC120V	4
19	Relay Base	Idec	SR2P05	4
20	5mm x 20mm BMA Glass Fuse	Bussman	GMA-4A	1
21	5mm x 20mm BMA Glass Fuse	Bussman	GMA-200ma	1
22	5mm x 20mm BMA Glass Fuse	Bussman	GMA-350ma	2
23	Din Rail Mount Duplex Receptacle 15A	Leviton	16252-DIN	1
24	Din Rail Mount Single Receptacle 15A	Phoenix	5604253	1
25	Fuse Cartridge plug ST-SI-UK4	Phoenix	921011	5
26	Fuse Cartridge Terminal Block UK4-TG	Phoenix	2812018	11
27	Terminal Block UK5N (Grey)	Phoenix	3004362	100
28	Terminal End Cover	Phoenix	3003020	2
29	End Stop	Phoenix	800886	2
30	Din Rail	Phoenix	1201730	6 ft
31	Terminal Marker Strip ZB6 1-10	Phoenix	1051029-1-10	6
32	Terminal Marker Strip ZB6 11-20	Phoenix	1051029-11-20	6
33	Terminal Marker Strip ZB6 21-30	Phoenix	1051029-21-30	6
34	Terminal Marker Strip ZB6 31-40	Phoenix	1051029-31-40	6
35	Terminal Marker Strip ZB6 CMS SPL, PR. (See Attached Sheet)	Phoenix	1050499	1
36	DIKD 1.5	Phoenix		6
37	UKKB 5	Phoenix		21
38	Communication Device (3 Options)			
38A	A) Cell Modem Option			
38B	B) Wireless Ethernet Radio 900MHz Option			
39	Surge Protector	Polyphaser	IS-50NX-C2	0
40	Wire Duct	Tyton	1.5x4	6 ft
41	Aluminum Bracket For Modem	Custom	5.5x9	1
42	Power Transfer Unit	Altronix	AL300LUB	1
43	Low Voltage Detector	Tyco	CSL-38-30010	1
44	12VDC, 28AH Seal Lead-Acid Battery	Power Sonic	PS12880	2
45	Circuit Breaker 1P 5 Amp	Allen-Bradley	1492-CB1G050	1
46	Relay 2 Pole Octal	Idec	RR2PULDC24V	1
47	Battery Bracket & Top Hat Bracket 1/8" Alum. 5"x23"	N/A	Custom	1
48	250 WATT Inverter	Xantrex	X Power 300	1

ITEM 38A

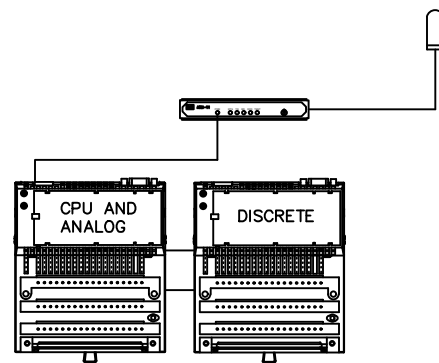

CELL MODEM OPTION

CELL MODEM OPTION COMPONENTS							
ITEM	QUANTITY			DESCRIPTION	MANUFACTURER	PART NO.	REMARKS
	TOTAL	LOCAL	REMOTE				
38A-1	1	1	0	CELL MODEM	SIERRA WIRELESS AIRLINK GX440 LTE	1101413	PLUG IN TO ITEM 23
38A-2	1	1	0	N-TYPE WIRELESS ADAPTER CABLE	LAIRD TECHNOLOGIES	COA5850 RG58A/U	N-TYPE MALE TO RP-5MA FEMALE, 5FT
38A-3	1	1	0	CELL ANTENNA	LAIRD TECHNOLOGIES	TRA6927M3PB-001	OMNI, Ph. PMT, BK, 698/1710 MHz, 3Dbi

ITEM 38B

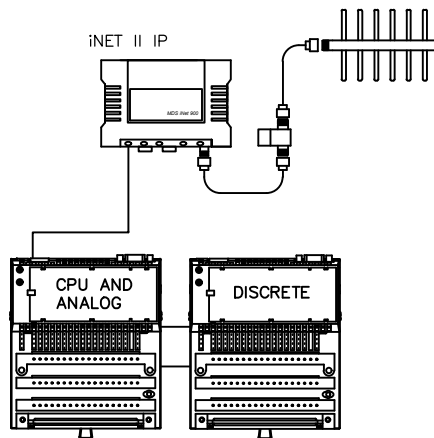

WIRELESS ETHERNET RADIO 900MHZ OPTION

RADIO OPTION COMPONENTS							
ITEM	QUANTITY			DESCRIPTION	MANUFACTURER	PART NO.	REMARKS
	TOTAL	LOCAL	REMOTE				
38B-1	1	1	0	ETHERNET RADIO	MDS	iNET-II IP	
38B-2	1	0	1	ETHERNET RADIO	MDS	iNET-II AP	
38B-3	2	1	1	CAT5 Crossover Cable			
38B-4	1	1	0	ANTENNA CABLE, LMR-400, 50 FT	TIMES	A40B-30	
38B-5	2	1	1	ANTENNA CABLE PIGTAIL, CABLE TYPE FSJ1, TYPE N MALE TO TYPE TNC MALE, 3 FT	ANDREWS	CONTACT ANDREWS	
38B-6	2	1	1	SURGE PROTECTOR	POLYPHASER	IS-50NX-C2	
38B-7	2	1	1	DIN Rail Bracket for MDS iNET 900 Radio	MDS	03-4022A02	
38B-8	2	1	1	DIRECTIONAL ANTENNA	SCALA	TY-900	
38B-9	0	0	0	OMNI ANTENNA (panel top mounting)	ANTENNEX	TRA9023NP	OPTION SEE NOTE 3

NOTES:

1. PROVIDE 35 FOOT MAST PER IRWD STD. DWG. W-15 (E-10) SHEET 14 OF 15 UNLESS OTHERWISE DIRECTED BY DISTRICT.
2. PROVIDE SECOND SET OF COMMUNICATIONS EQUIPMENT FOR INSTALLATION BY OTHERS AT REMOTE SITE. REFER TO PROJECT DOCUMENTS FOR INSTALLATION REQUIREMENTS AT REMOTE SITE.
3. ALTERNATIVE ANTENNA, USE IF APPROVED BY IRWD FOR A SPECIFIC SITE.

PRESSURE REGULATING STATION (PRV)

IRVINE RANCH WATER DISTRICT, ENGINEERING DEPARTMENT

APPROVED BY:

KEVIN L. BURTON R.M.E. M28832
EXECUTIVE DIRECTOR, TECHNICAL SERVICES

FEBRUARY 2025
REVISION



IRWD
STD. DWG.
W-15 (E-6)

NOT TO SCALE
SHEET 10 OF 15

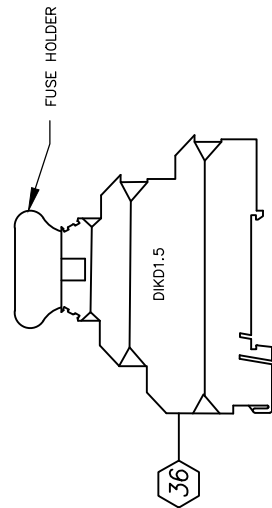

3-TIER TERMINAL - FOR ANALOG I/O

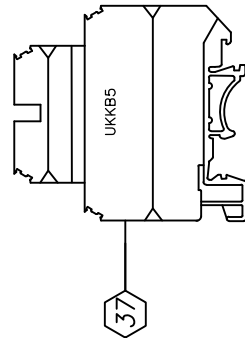

2-TIER TERMINAL - FOR DISCRETE I/O

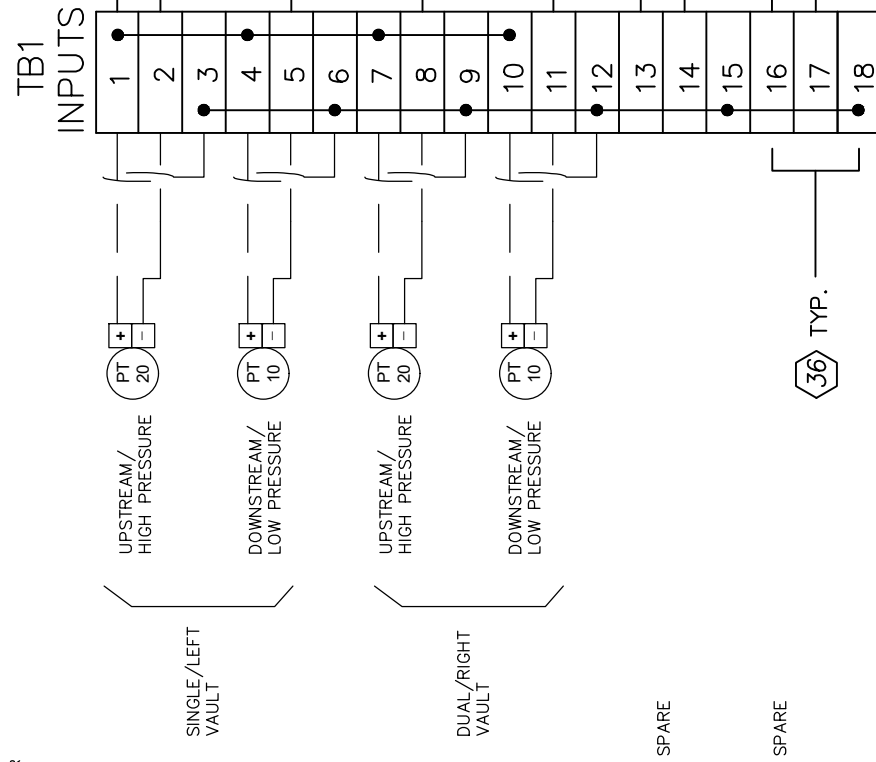

NOTE:

1. REMOVE JUMPER FOR DUAL VAULT FACILITIES.

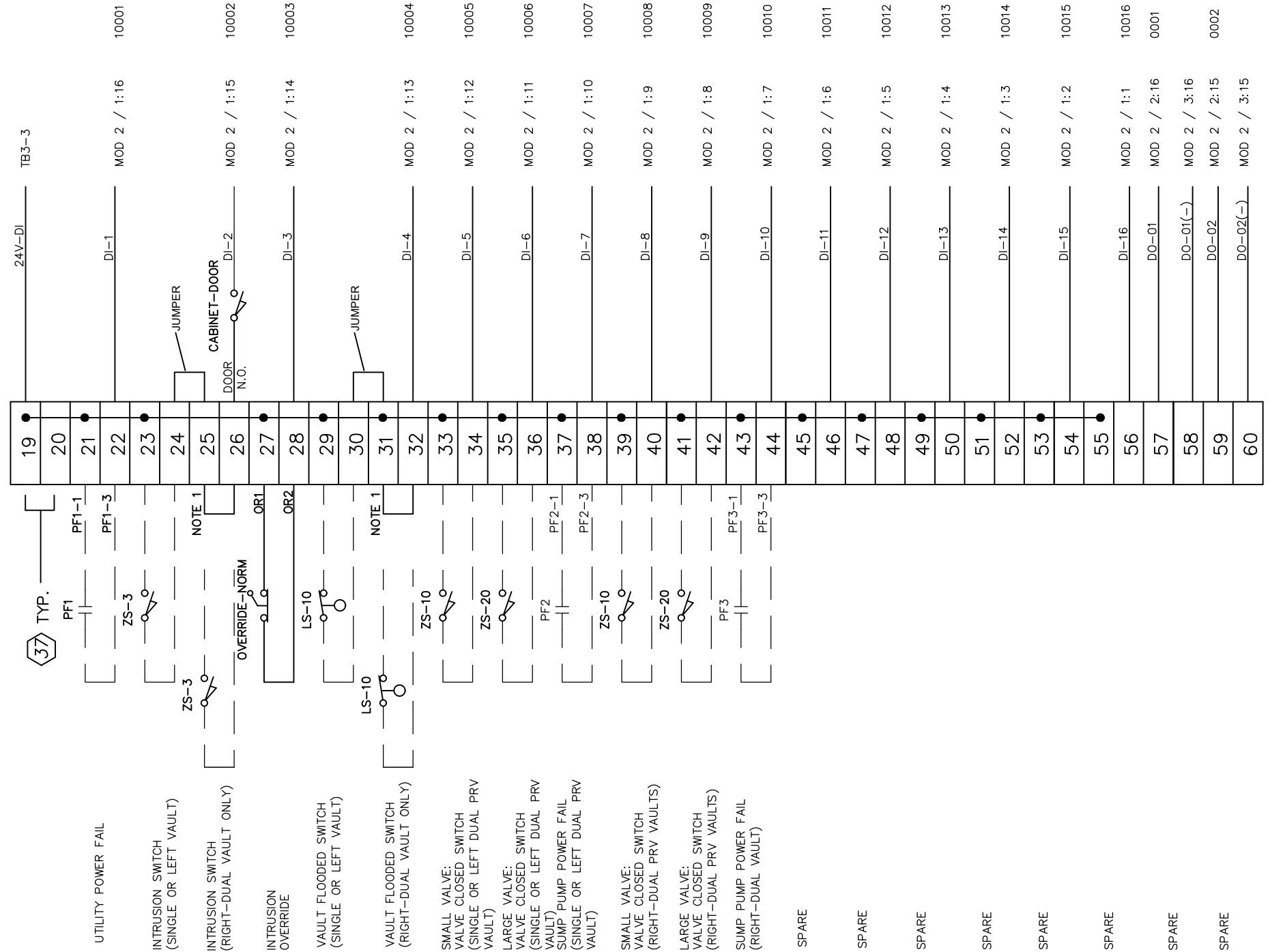

PRESSURE REGULATING STATION (PRV)

IRVINE RANCH WATER DISTRICT, ENGINEERING DEPARTMENT

APPROVED BY:

 KEVIN L. BURTON R.M.E. M28832
 EXECUTIVE DIRECTOR, TECHNICAL SERVICES

FEBRUARY 2025
 REVISION



IRWD
STD. DWG.
W-15 (E-7)
 NOT TO SCALE
 SHEET 11 OF 15

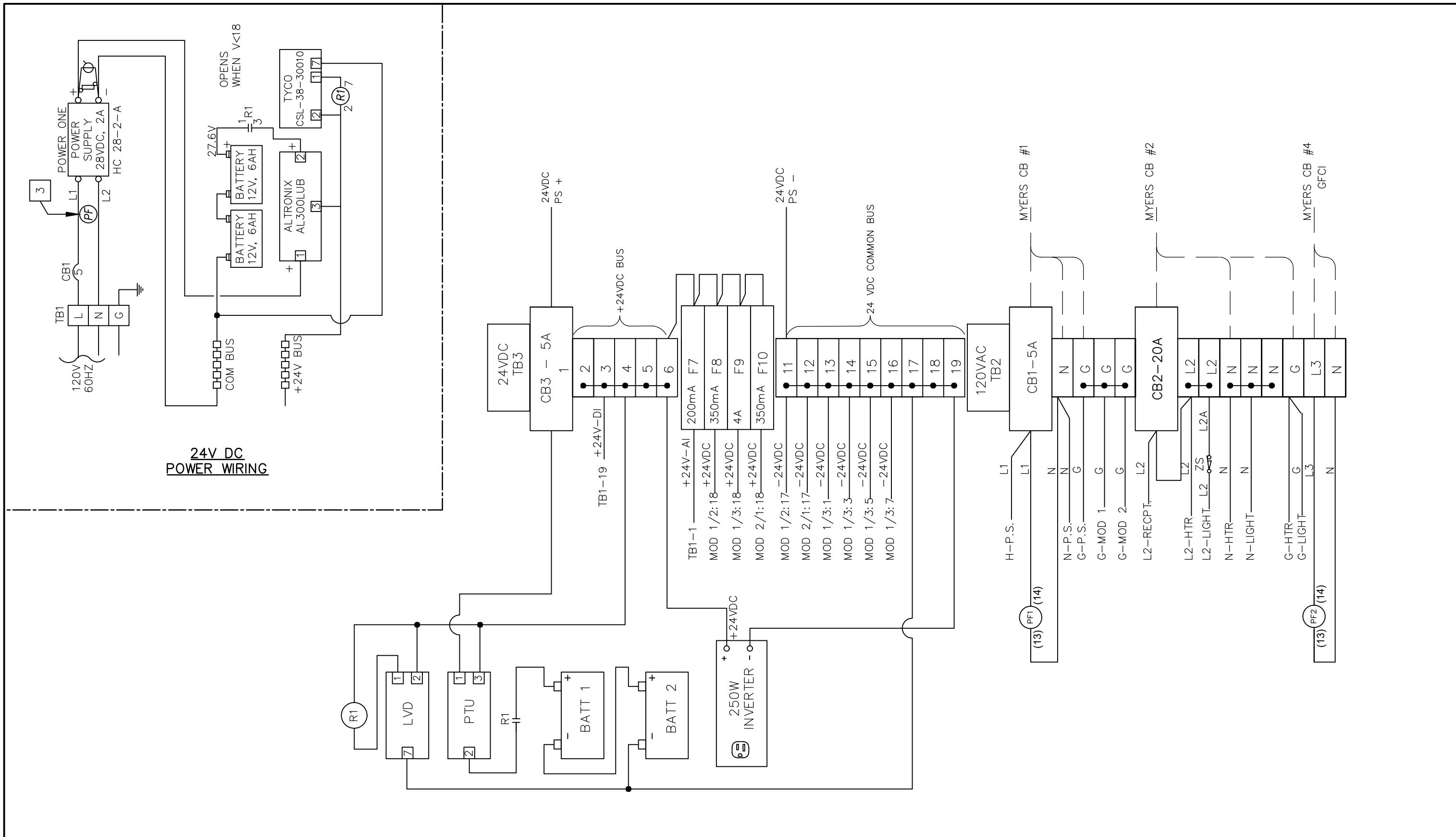

**24V DC
POWER WIRING**

NOTE:
1. REMOVE JUMPER FOR DUAL VAULT FACILITIES.

PRESSURE REGULATING STATION (PRV)	
IRVINE RANCH WATER DISTRICT, ENGINEERING DEPARTMENT	
APPROVED BY: KEVIN L. BURTON R.M.E. M28832 EXECUTIVE DIRECTOR, TECHNICAL SERVICES	FEBRUARY 2025 REVISION
Irvine Ranch WATER DISTRICT	IRWD STD. DWG. W-15 (E-8) NOT TO SCALE SHEET 12 OF 15

ETHERNET PORT
CONNECTION FOR
OPTION 38A OR 38B

ANALOG - 4 CH. IN / 2 CH. OUT

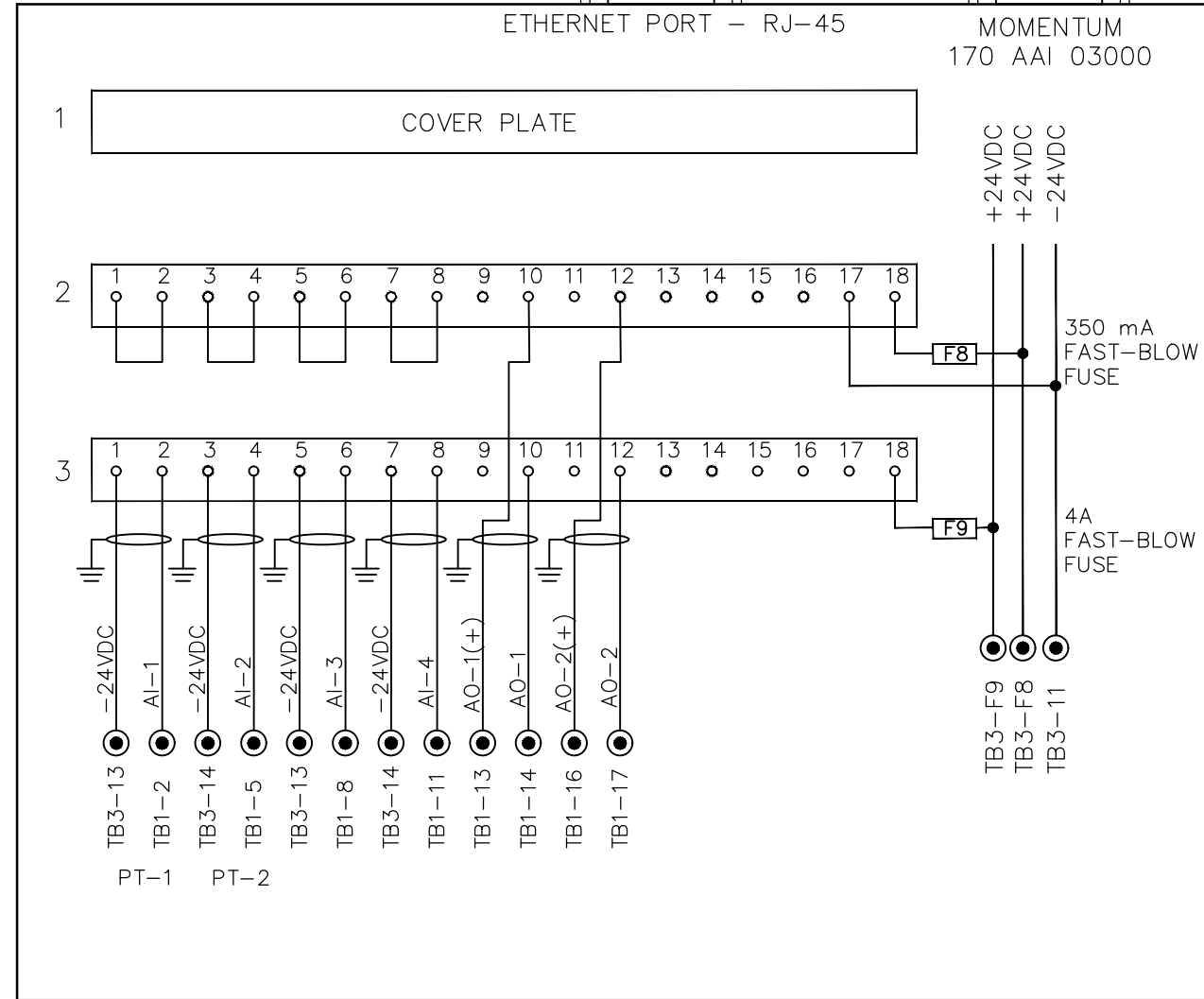

MODULE 1

24VDC DISCRETE - 16 PT. IN / 16 OUT

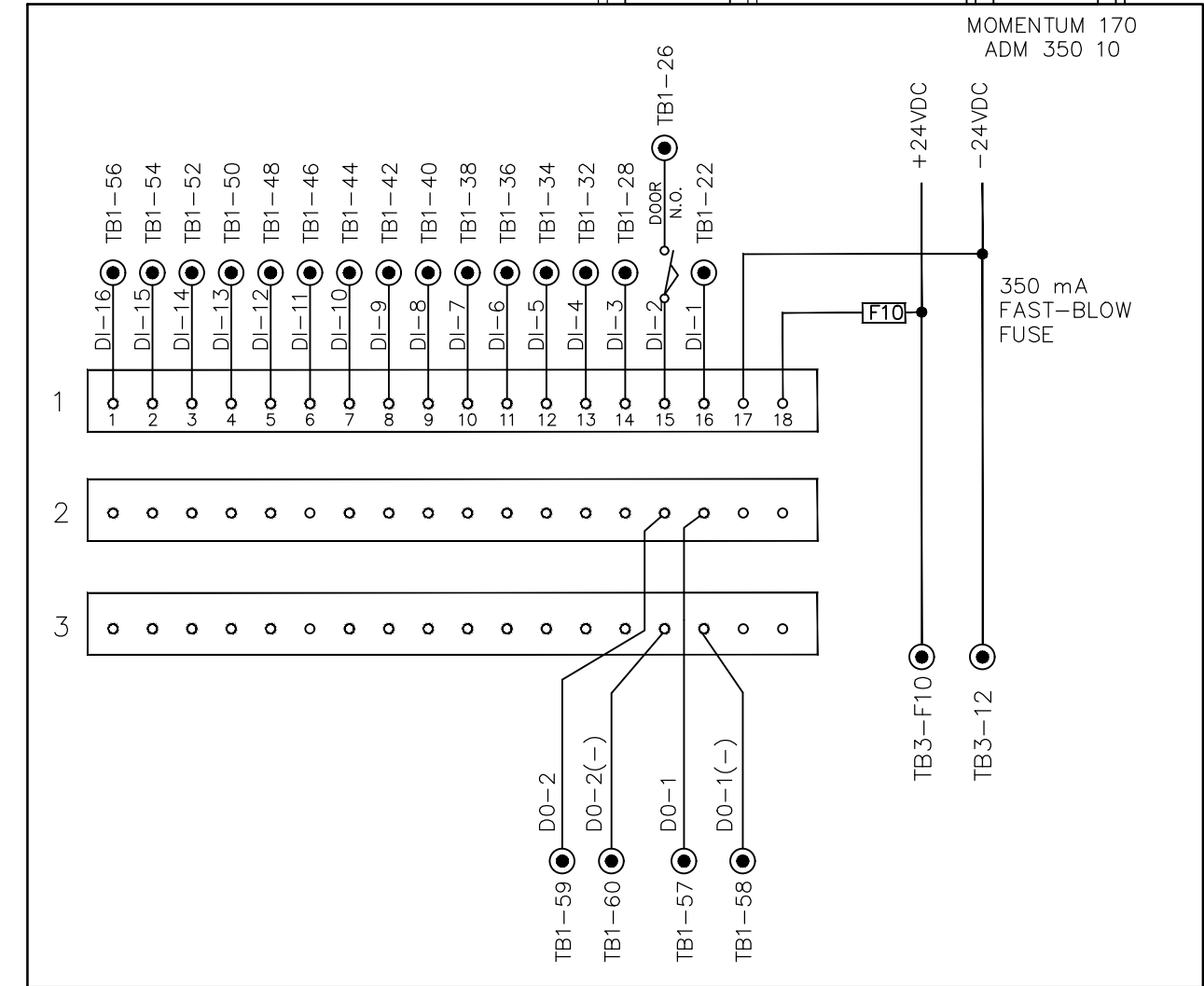

MODULE 2

PRESSURE REGULATING VALVE (PRV)

IRVINE RANCH WATER DISTRICT, ENGINEERING DEPARTMENT
 APPROVED BY:
Kevin L. Burton
 KEVIN L. BURTON R.M.E. M28832
 EXECUTIVE DIRECTOR, TECHNICAL SERVICES

FEBRUARY 2025
 REVISION



IRWD
 STD. DWG.
 W-15 (E-9)
 NOT TO SCALE
 SHEET 13 OF 15

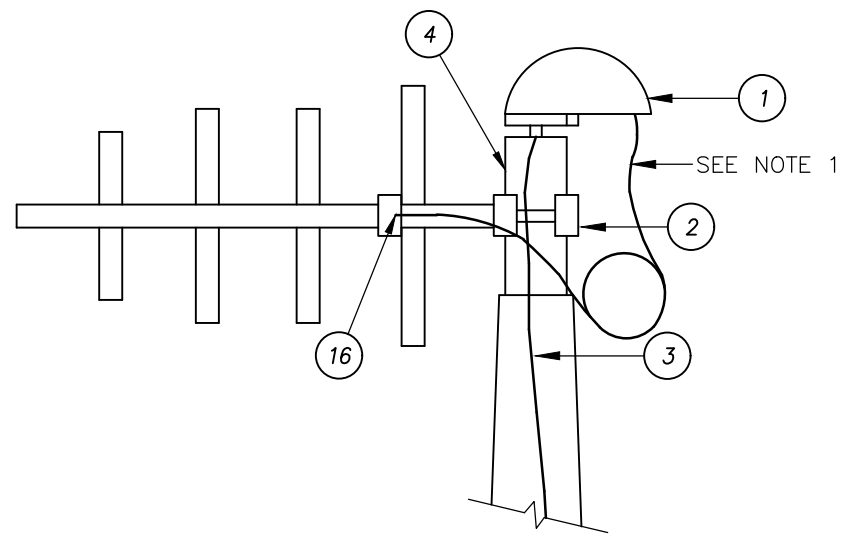
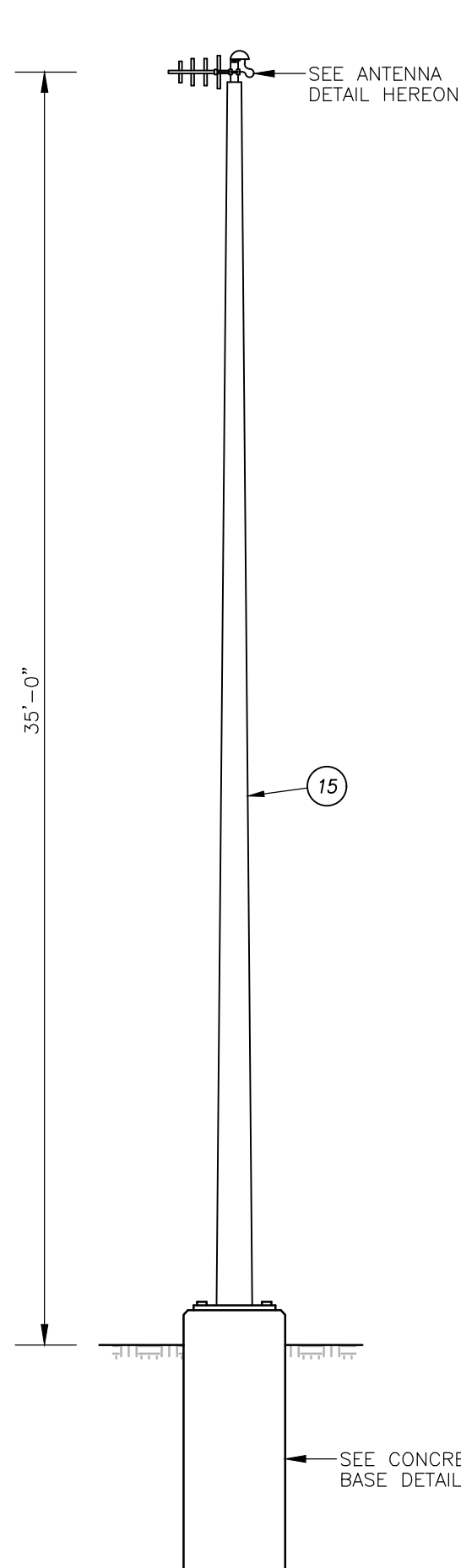

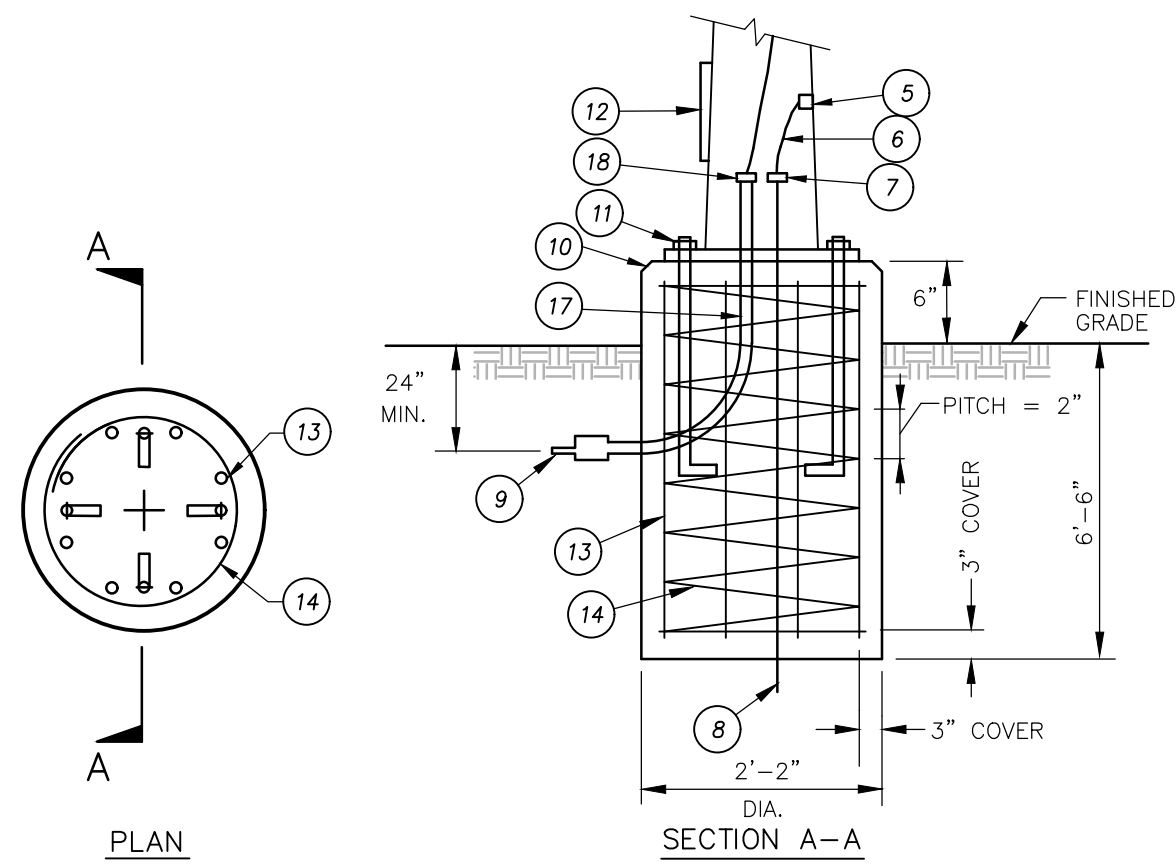

ANTENNA DETAIL



CONCRETE BASE DETAIL

ITEM	MATERIALS
1	2" WEATHER HEAD.
2	ANTENNA WITH MOUNTING HARDWARE.
3	ANTENNA COAXIAL CABLE. PROVIDE CABLE GRIP TO SUPPORT CABLE WEIGHT.
4	2" X 12" OR 18" TENYON.
5	GROUND LUG.
6	#6 BOND WIRE.
7	ACORN CONNECTOR.
8	COPPER GROUND ROD, 10' X 5/8" DIAMETER.
9	CONDUIT TO TELEMETRY RADIO.
10	1/4" CHAMFER AT TOP EDGE OF CONCRETE BASE.
11	(4) 1" X 36" X 4" ANCHOR BOLTS WITH DOUBLE LOCKNUTS.
12	HANDHOLE COVER.
13	(8) #7 BARS.
14	3/8" SPIRALS WITH 20" DIA.
15	ANTENNA MAST. HEIGHT SHALL BE 35'.
16	ANTENNA CABLE CONNECTIONS. PROVIDE WEATHERPROOF SEAL BETWEEN CABLE AND ANTENNA CONNECTION.
17	2" OCAL RISER.
18	2" GROUND BUSHING.

- NOTES:**
1. PROVIDE WEATHER HEAD, DRIP LOOP, AND VAPOR-WRAP FOR EXPOSED RF CONNECTORS.
 2. THIS DETAIL IS FOR INFORMATION ONLY AND NOT FOR CONSTRUCTION. STRUCTURAL DESIGN MUST BE REVIEWED AND APPROVED BY THE ENGINEER OF RECORD FOR EACH PROJECT.
 3. ALLOWABLE SOIL BEARING CAPACITY ASSUMED TO BE 1,500 PSF.
 4. ASSUMED GRADE 60 REBARS, ALLOWABLE STRESS = 24,000 PSI.
 5. ASSUMED $f'_c = 3,000$ PSI AND $f_y = 40,000$ PSI.

POLE MOUNTED ANTENNA AND FOUNDATION		 IRWD STD. DWG. W-15 (E-10)
IRVINE RANCH WATER DISTRICT, ENGINEERING DEPARTMENT APPROVED BY:  KEVIN L. BURTON R.M.E. M28832 EXECUTIVE DIRECTOR, TECHNICAL SERVICES		
		NOT TO SCALE SHEET 14 OF 15

ITEM	D/I	STATUS	DESCRIPTION	PRE-TEST	TEST		RETEST	
					PASS	FAIL	PASS	FAIL
1	DI-1	NO	TELEMETRY PANEL POWER FAIL (PF-1)					
2	DI-2	NO	TELEMETRY PANEL INTRUSION SWITCH					
3-L	DI-2	NO	VAULT INTRUSION SWITCH					
4-R	DI-2	NO	VAULT INTRUSION SWITCH					
5	DI-3	NC	INTRUSION OVERRIDE SWITCH					
6-L	DI-4	NC	VAULT FLOODED SWITCH					
7-R	DI-4	NC	VAULT FLOODED SWITCH					
8-L	DI-5	NO	SMALL VALVE CLOSED SWITCH					
9-L	DI-6	NO	LARGE VALVE CLOSED SWITCH					
10-L	DI-7	NO	SUMP PUMP POWER FAIL (PF-2)					
11-R	DI-8	NO	SMALL VALVE CLOSED SWITCH					
12-R	DI-9	NO	LARGE VALVE CLOSED SWITCH					
13-R	DI-10	NO	SUMP PUMP POWER FAIL (PF-3)					
14U-L	AI-1	4-20m A	PRESSURE TRANSMITTER 0- _____ psi PRESSURE _____ psi MILLIAMP _____ mA, ACTUAL _____ mA					
15D-L	AI-2	4-20m A	PRESSURE TRANSMITTER 0- _____ psi PRESSURE _____ psi MILLIAMP _____ mA, ACTUAL _____ mA					
16U-R	AI-3	4-20m A	PRESSURE TRANSMITTER 0- _____ psi PRESSURE _____ psi MILLIAMP _____ mA, ACTUAL _____ mA					
17D-R	AI-4	4-20m A	PRESSURE TRANSMITTER 0- _____ psi PRESSURE _____ psi MILLIAMP _____ mA, ACTUAL _____ mA					
18		<25ohms	METER PANEL GROUND ROD RESISTANCE (MUST BE <25ohms)					
19		<25ohms	TELEMETRY PANEL GROUND ROD RESISTANCE (MUST BE <25ohms)					
20			TRIP TEST GROUND FAULT RECEPTACLES					
21			PUMP WATER WITH THE SUMP PUMP CHECK FOR PROPER OPERATION					
22		>30min.	VERIFY BACK UP POWER > 30 min. TYPE: TYPE: UPS _____ BATTERY _____					

COMMENTS: _____

NOTES: _____

1. L=LEFT VAULT, R=RIGHT VAULT
2. IF ONLY ONE VAULT USE THE I/O FOR THE LEFT VAULT
3. IF ONLY ONE VALVE USE THE I/O FOR THE LARGE VALVE
4. CONTRACTOR SHALL PERFORM THE PRE-TEST BEFORE THE DISTRICT START-UP TEST

CONTRACTOR RESPONSIBLE FOR WORK: _____

CONTRACTOR REPRESENTATIVE: _____

NAME DATE

IRWD REPRESENTATIVE: _____

NAME DATE

PROJECT NAME: _____

PROJECT LOCATION: _____

IRWD PROJECT/TRACT NUMBER: _____

PRESSURE REGULATING STATION - ELECTRICAL TEST CERTIFICATION

IRVINE RANCH WATER DISTRICT, ENGINEERING DEPARTMENT

APPROVED BY:



KEVIN L. BURTON R.M.E. M28832
EXECUTIVE DIRECTOR, TECHNICAL SERVICES

FEBRUARY 2025
REVISION



**IRWD
STD. DWG.
W-15 (E-11)**

NOT TO SCALE
SHEET 15 OF 15

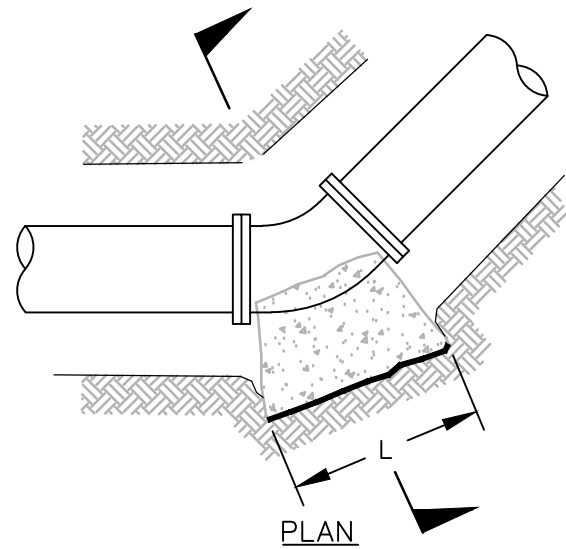

COAT REBAR WITH 80 MILS OF COLD-APPLIED BITUMASTIC WATER-PROOFING COMPOUND

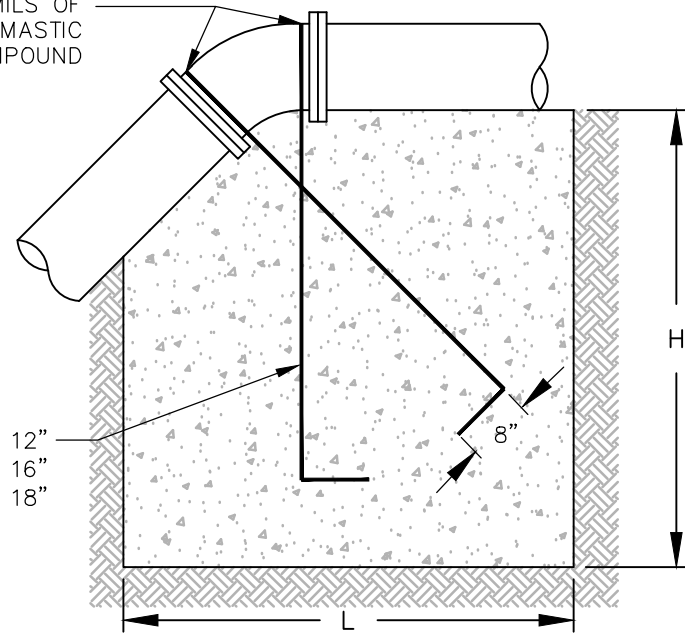

(2) #4 BARS FOR PIPE SIZES UP TO 12"
 (2) #5 BARS FOR PIPE SIZE 16"
 (2) #6 BARS FOR PIPE SIZE 18"

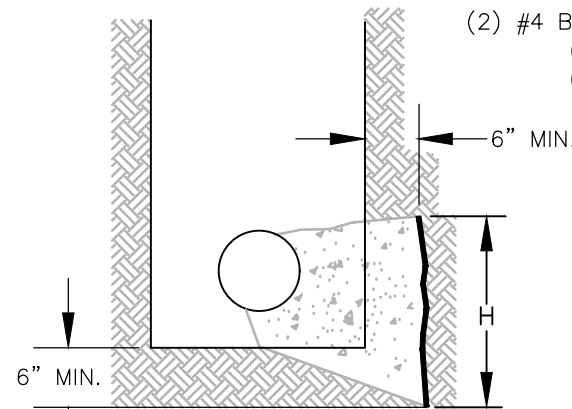

SECTION
HORIZONTAL BEND

SECTION
VERTICAL BEND ANCHOR

VERTICAL BEND ANCHOR BLOCK *						
PIPE SIZE (IN)	22 1/2° BEND L, H, W (IN)	VOLUME (YD ³)	THRUST (LBS)	45° BEND L, H, W (IN)	VOLUME (YD ³)	THRUST (LBS)
4	26	0.4	1,104	32	0.7	2,165
6	34	0.8	2,483	42	1.6	4,871
8	41	1.5	4,414	51	2.8	8,659
10	47	2.2	6,897	59	4.4	13,529
12	53	3.2	9,932	67	6.4	19,482

* FOR DUCTILE IRON PIPE, ALL VERTICAL BENDS SHALL BE MECHANICALLY RESTRAINED. SEE NOTE 14 ON SHEET 3 OF 3.

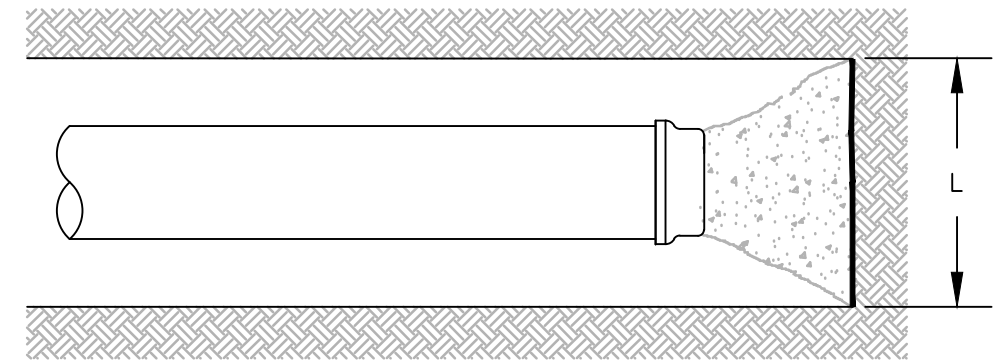

END OF LINE

HORIZONTAL BEND THRUST BLOCK																				
PIPE SIZE (IN)	11 1/4° BEND				22 1/2° BEND				45° BEND				90° BEND				END OF LINE			
	L (IN)	H (IN)	AREA (IN ²)	THRUST (LBS)	L (IN)	H (IN)	AREA (IN ²)	THRUST (LBS)	L (IN)	H (IN)	AREA (IN ²)	THRUST (LBS)	L (IN)	H (IN)	AREA (IN ²)	THRUST (LBS)	L (IN)	H (IN)	AREA (IN ²)	THRUST (LBS)
4	12	6	72	554	16	8	128	1,104	23	12	276	2,165	31	16	496	4,000	26	13	338	2,828
6	17	9	153	1,248	24	12	288	2,483	34	17	578	4,871	46	23	1,058	9,000	39	20	780	6,364
8	23	12	276	2,218	32	16	512	4,414	45	23	1,035	8,659	61	31	1,891	15,999	52	26	1,352	11,313
10	29	15	435	3,465	40	20	800	6,897	56	28	1,568	13,529	76	38	2,888	24,999	64	32	2,048	17,677
12	34	17	578	4,990	48	24	1,152	9,932	67	34	2,278	19,482	92	46	4,232	35,999	77	39	3,003	25,455

NOTE:

1. SEE SHEET 3 OF 3 FOR ADDITIONAL NOTES.

THRUST BLOCK

IRVINE RANCH WATER DISTRICT, ENGINEERING DEPARTMENT

APPROVED BY:

Kevin L. Burton
 KEVIN L. BURTON R.M.E. M28832
 EXECUTIVE DIRECTOR, TECHNICAL SERVICES

FEBRUARY 2025
 REVISION



IRWD
 STD. DWG.
 W-16

NOT TO SCALE
 SHEET 1 OF 3

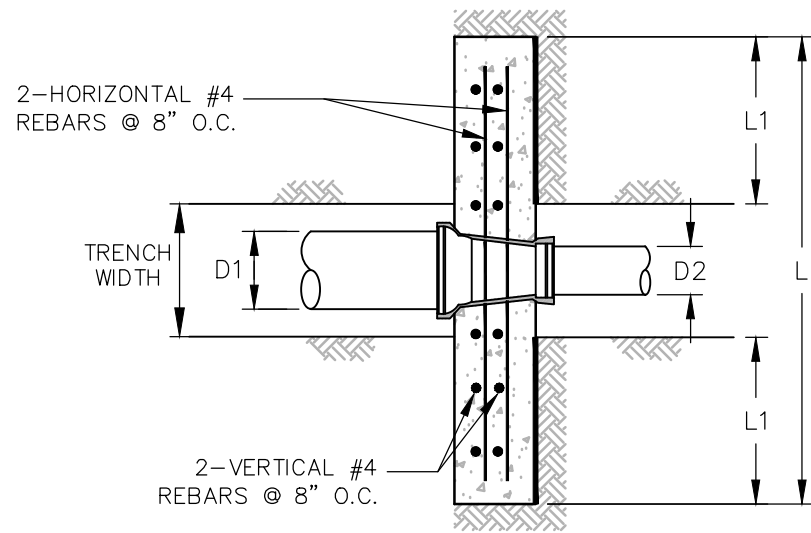

PLAN

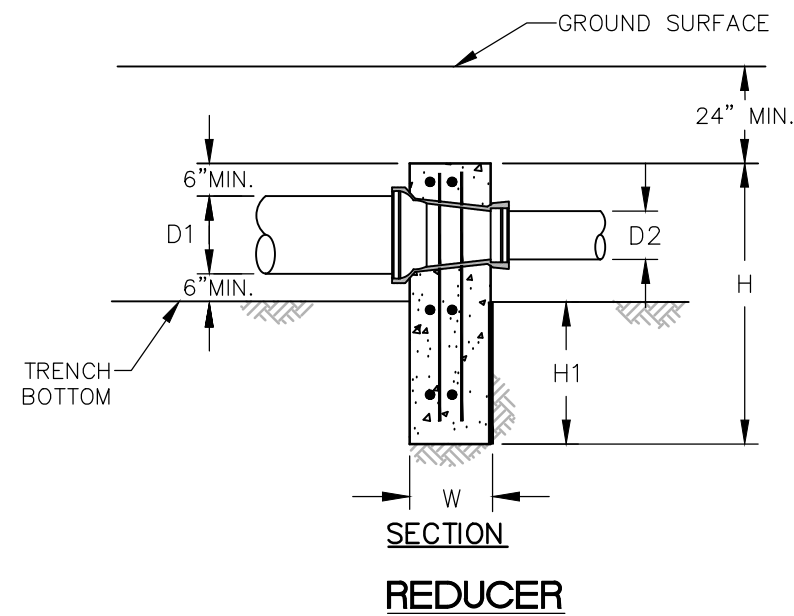

SECTION
REDUCER

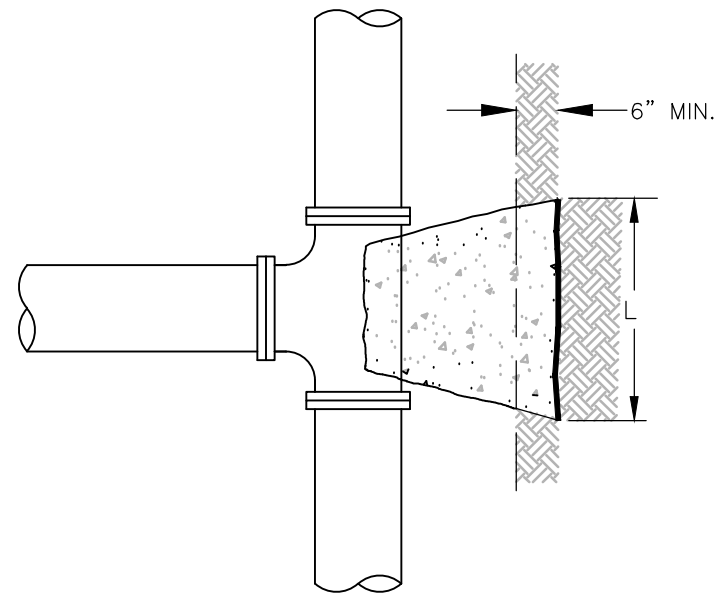

PLAN

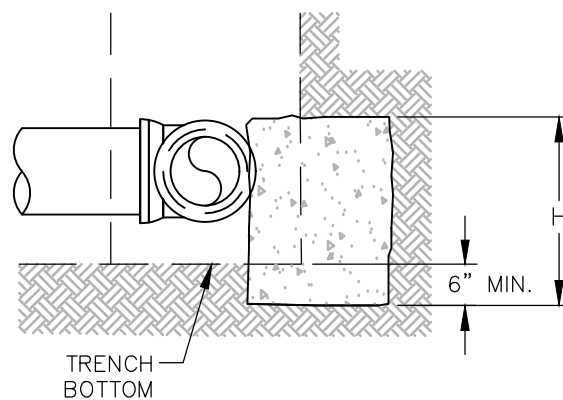

SECTION
TEE

PIPE SIZE (IN)	TEE			
	L (IN)	H (IN)	AREA (IN ²)	THRUST (LBS)
4	26	13	338	2,828
6	39	20	780	6,364
8	52	26	1,352	11,313
10	64	32	2,048	17,677
12	77	39	3,003	25,455

D1xD2 (IN)	REDUCER							TOTAL AREA INCLD. TRENCH (IN ²)	MIN. BEARING AREA** (IN ²)	THRUST (LBS)
	TRENCH WIDTH* (IN)	L (IN)	H (IN)	H1 (IN)	L1 (IN)	W (IN)				
12X10	30	52	34	8	11	12	1,768	954	7,778	
12X8	30	62	41	15	16	12	2,542	1,762	14,142	
12X6	30	68	45	19	19	12	3,060	2,280	19,091	
12X4	30	72	48	22	21	10	3,456	2,676	22,627	
10X8	30	48	32	8	9	10	1,536	816	6,364	
10X6	30	56	37	13	13	10	2,072	1,352	11,313	
10X4	30	62	41	17	16	10	2,542	1,822	14,849	
8X6	24	42	28	6	9	10	1,176	648	4,950	
8X4	24	48	32	10	12	8	1,536	1,008	8,485	
6X4	24	38	25	5	7	8	950	470	3,535	

* IF A DIFFERENT TRENCH WIDTH IS USED, THE THRUST BLOCK SHALL MAINTAIN THE MIN. BEARING AREA SHOWN.
 ** BEARING AREA REQUIRED ON UNDISTURBED SOIL OUTSIDE OF TRENCH.

NOTE:

1. SEE SHEET 3 OF 3 FOR ADDITIONAL NOTES.

THRUST BLOCK

IRVINE RANCH WATER DISTRICT, ENGINEERING DEPARTMENT

APPROVED BY:

Kevin L. Burton

KEVIN L. BURTON R.M.E. M28832
 EXECUTIVE DIRECTOR, TECHNICAL SERVICES

FEBRUARY 2025
 REVISION



IRWD
 STD. DWG.
 W-16

NOT TO SCALE
 SHEET 2 OF 3

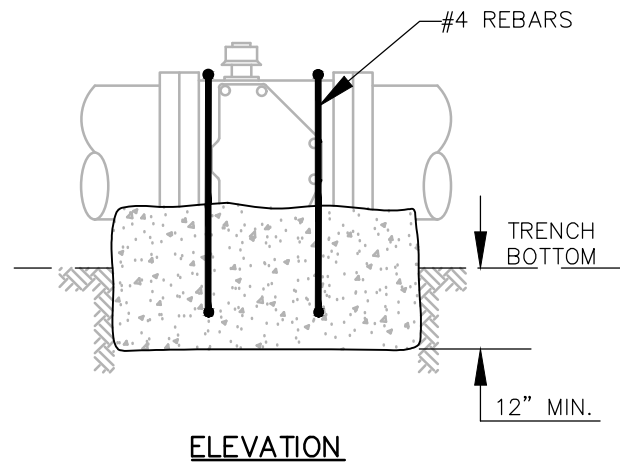

ELEVATION

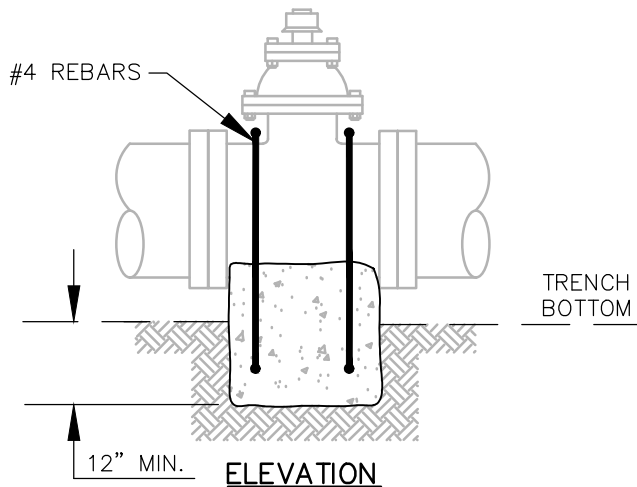

ELEVATION

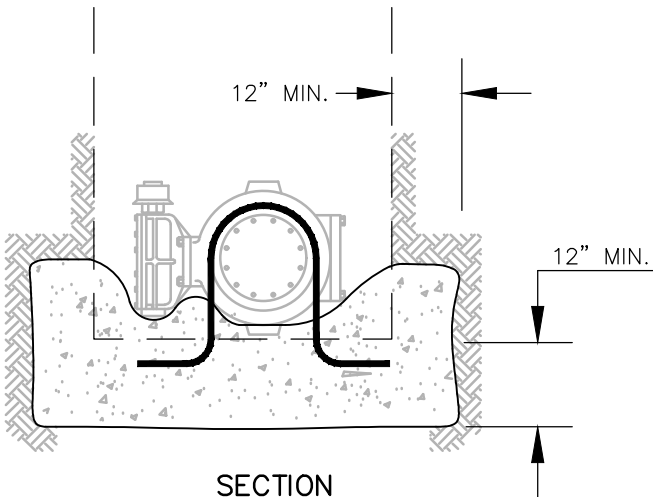

SECTION

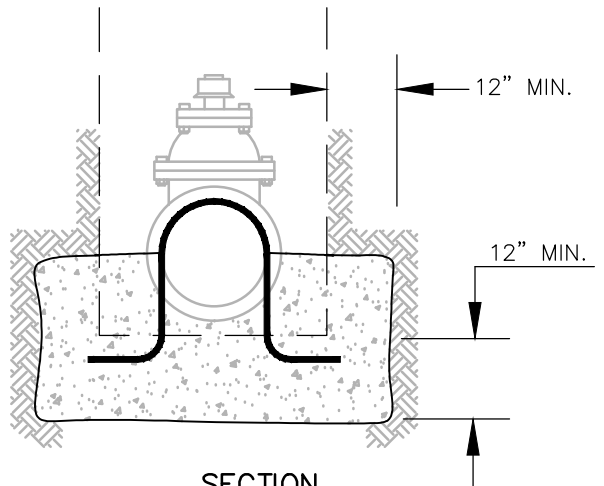

SECTION

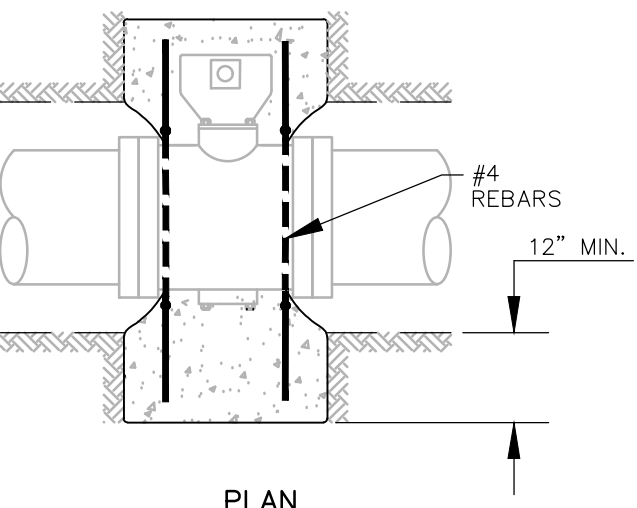

PLAN

BUTTERFLY VALVES

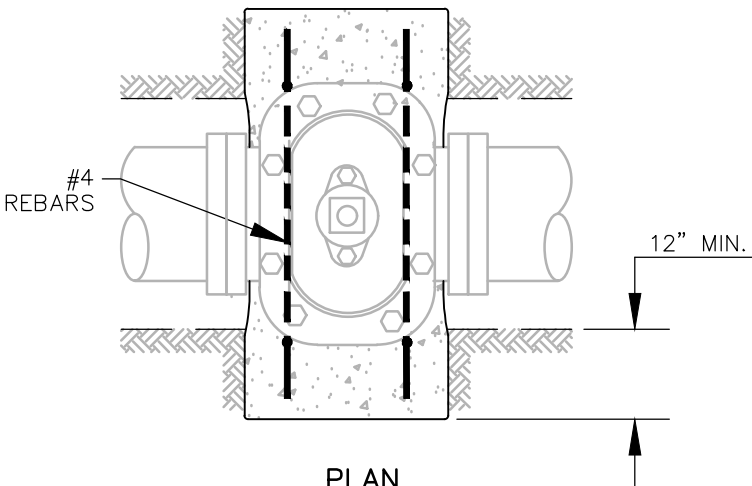



PLAN

GATE VALVES

NOTES:

1. THRUST BLOCK BEARING AREA BASED ON ALLOWABLE SOIL BEARING VALUE OF 1500 PSF PRESSURE, 225 PSI LINE PRESSURE WITH 3'-0" COVER MIN., AND A MIN. SAFETY FACTOR OF 1.2.
FOR BEARING = 1000 PSF, 1.5 X AREA SHOWN
FOR BEARING = 500 PSF, 3.0 X AREA SHOWN
2. ALL THRUST BLOCKS SHALL BE PORTLAND CEMENT CONCRETE MIX 560-C-3250 AND PLACED AGAINST UNDISTURBED SOIL.
3. THRUST BLOCKS ON REDUCERS SHALL BE KEYED INTO THE TRENCH BOTTOM AS SHOWN.
4. CONCRETE SHALL NOT EXTEND ONTO FLANGE OR ADJOINING PIPE.
5. DO NOT COVER FITTING BOLTS WITH CONCRETE.
6. WHEN VALVES ARE FLANGED TO FITTINGS, AVOID PLACING CONCRETE ON ANY PART OF THE VALVE BONNET OR VALVE OPERATOR.
7. COAT REBAR WITH 80 MILS OF COLD-APPLIED BITUMASTIC WATER-PROOFING COMPOUND. WRAP EXTERIOR OF VALVE, ACTUATOR AND REBAR WITH 8 MIL POLYETHYLENE SHEETING AND TAPE PER IRWD SPEC. SECTION 15100.
8. MIN. CONCRETE COVER OVER REBAR SHALL BE 3".
9. NO CONCRETE SHALL BE POURED ON VALVE OR PIPE JOINT.
10. YIELD STRENGTH OF STEEL BARS IS ASSUMED TO BE 36 KSI.
11. FOR PIPELINES LARGER THAN 12" IN DIA., THE ENGINEER SHALL CALCULATE THRUST BLOCK SIZE BASED ON PROJECT SPECIFIC SOIL CONDITIONS AND SHALL SUBMIT THE CALCULATIONS TO THE DISTRICT FOR APPROVAL.
12. MECHANICAL THRUST RESTRAINTS SHALL BE PROVIDED IN LIEU OF THRUST OR ANCHOR BLOCKS IF THE BEARING FACE OF THE THRUST OR ANCHOR BLOCK MAY BE DISTURBED AT ANY POINT AFTER CONSTRUCTION OR DURING CONSTRUCTION OF OTHER FACILITIES.
13. WHERE MECHANICAL THRUST RESTRAINTS ARE PROVIDED, THE ENGINEER SHALL CALCULATE THE REQUIRED LENGTH OF THRUST RESTRAINT ALONG THE PIPELINE ALIGNMENT AND SHALL SUBMIT THE CALCULATIONS TO THE DISTRICT FOR APPROVAL.
14. DUCTILE IRON PIPE JOINT FITTINGS SHALL BE MECHANICALLY RESTRAINED AT ALL VERTICAL BENDS. VERTICAL BEND ANCHOR BLOCKS SHALL ONLY BE PROVIDED WHERE APPROVED BY DISTRICT.
15. CONCRETE SHALL BE MIXED THROUGH A READY-MIX OR A BATCH TYPE MIXER. REFER TO IRWD SPEC. SECTION 03300 FOR ADDITIONAL REQUIREMENTS.

THRUST BLOCK		 IRWD STD. DWG. W-16
IRVINE RANCH WATER DISTRICT, ENGINEERING DEPARTMENT APPROVED BY:  KEVIN L. BURTON R.M.E. M28832 EXECUTIVE DIRECTOR, TECHNICAL SERVICES		
		NOT TO SCALE SHEET 3 OF 3

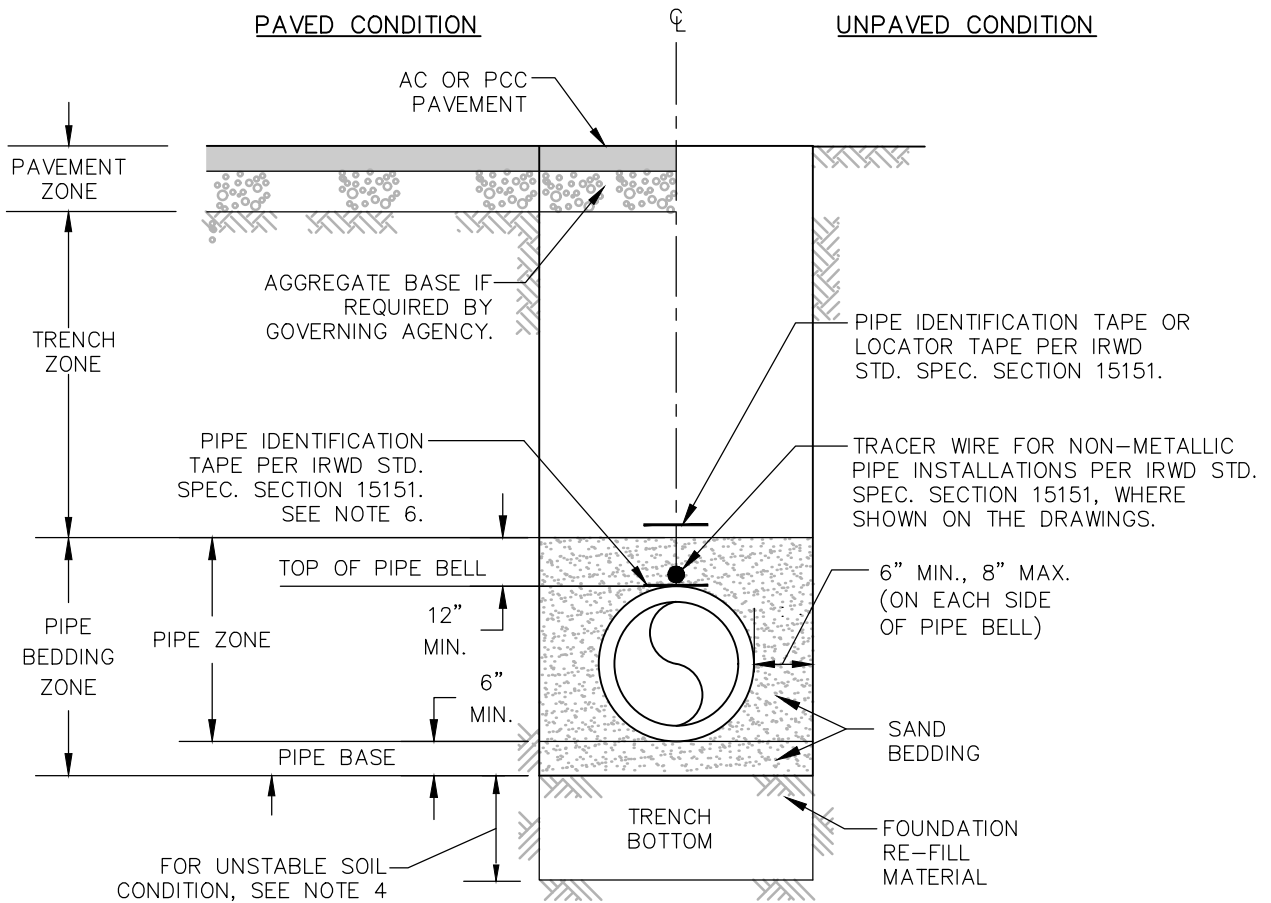

NOTES:

1. ALL WORK SHALL BE PER IRWD STD. SPEC. SECTION 02223.
2. PIPE BASE SHALL BE A MIN. OF 6" IN DEPTH. PIPE BEDDING MATERIAL SHALL BE PER IRWD STD. SPEC. SECTION 02223 AND SHALL INCLUDE BOTH PIPE BASE AND PIPE BEDDING ZONE.
3. CONTRACTOR SHALL PROVIDE HAND EXCAVATED "BELL HOLE" FOR EACH PIPE JOINT SO THAT THE WEIGHT OF PIPE DOES NOT BEAR ON THE BELL. CONTRACTOR SHALL RE-FILL AND HAND-TAMP EACH "BELL HOLE" PRIOR TO COMPLETING THE PLACEMENT OF PIPE BEDDING.
4. IF UNSTABLE SOIL IS ENCOUNTERED, THE DISTRICT REPRESENTATIVE SHALL DETERMINE OVEREXCAVATION DEPTH AND FOUNDATION RE-FILL MATERIAL PER IRWD STD. SPEC. SECTION 02223.
5. WHERE CONTRACTOR FAILS TO MAINTAIN PROPER TRENCH WIDTH LIMITS, SPECIAL BACKFILL SUCH AS ONE-SACK SLURRY AND BEDDING SHALL BE USED AS DETERMINED IN THE FIELD BY THE DISTRICT REPRESENTATIVE.
6. PIPE IDENTIFICATION TAPE SHALL BE INSTALLED PER IRWD STD. SPEC. SECTION 15151. TAPE SHALL BE FASTENED TO THE PIPE WITH 2" WIDE 10 MIL PIPE WRAP TAPE. PIPE WRAP TAPE SHALL BE WRAPPED AROUND THE ENTIRE CIRCUMFERENCE OF THE PIPE.
7. THE MIN. DEPTH OF COVER FROM FINISH GRADE TO THE TOP OF THE PIPELINE SHALL BE AS FOLLOWS UNLESS OTHERWISE APPROVED BY IRWD:
 - DOMESTIC WATER PIPELINE (1" TO 10" DIA.) = 42"
 - DOMESTIC WATER PIPELINE (> 10" DIA.) = 48"
 - RECYCLED WATER PIPELINE (ALL DIA.) = 60"

WATER TRENCH

IRVINE RANCH WATER DISTRICT, ENGINEERING DEPARTMENT

APPROVED BY:

KEVIN L. BURTON R.M.E. M28832
EXECUTIVE DIRECTOR, TECHNICAL SERVICES

FEBRUARY 2025
REVISION



Irvine Ranch
WATER DISTRICT

**IRWD
STD. DWG.
W-17**

NOT TO SCALE
SHEET 1 OF 1

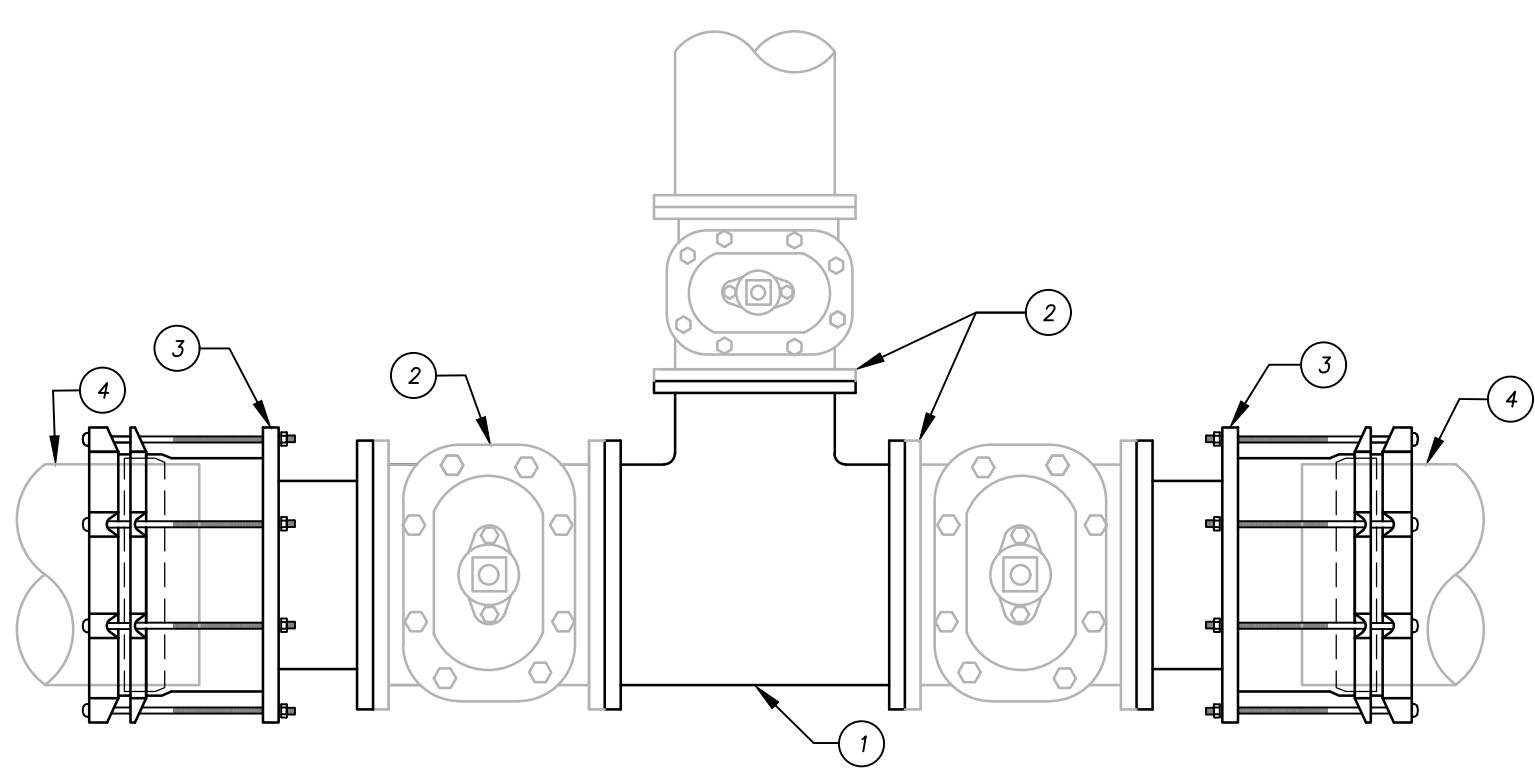

OPTION 1

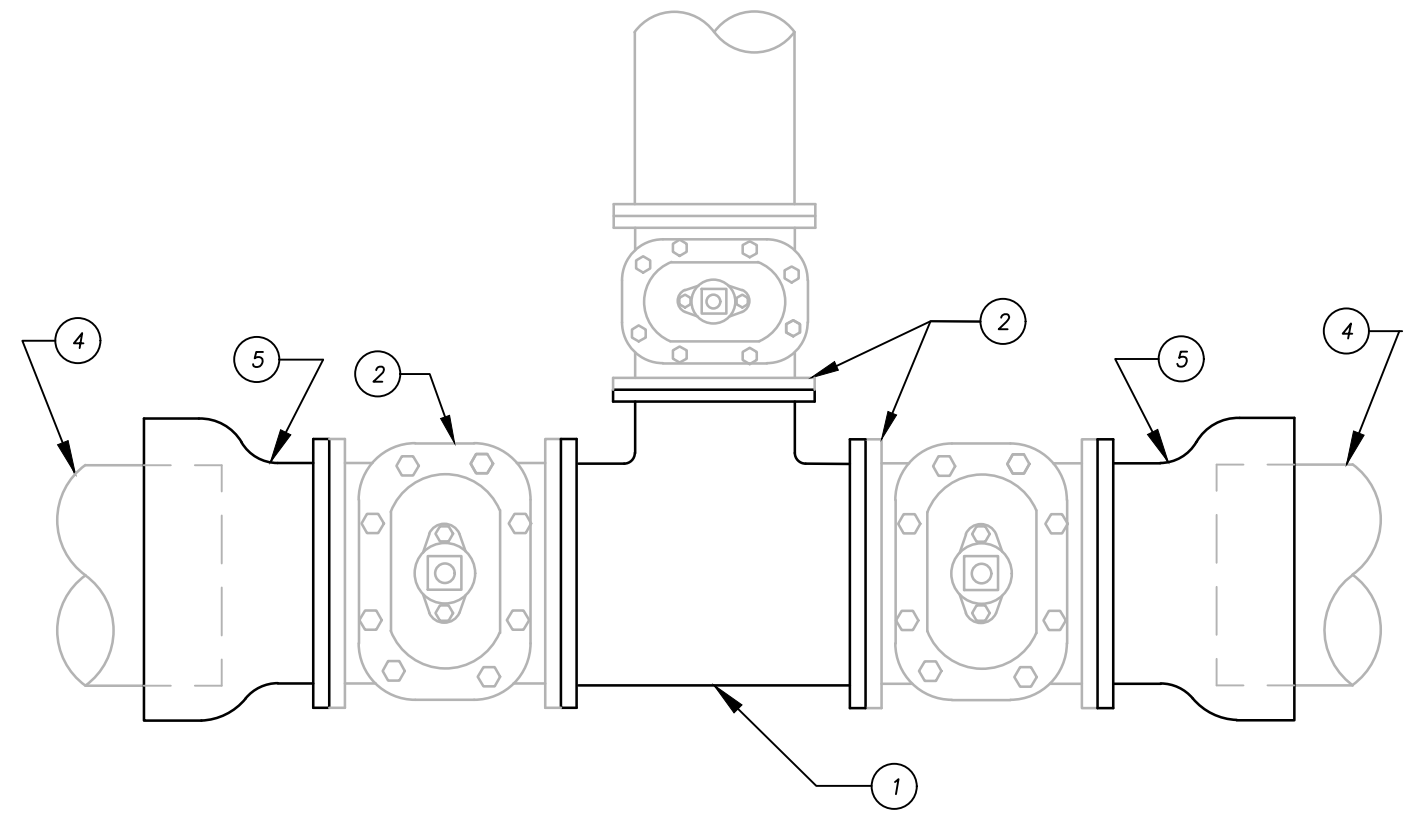

OPTION 2

- | ITEM | MATERIALS |
|------|---|
| 1 | D.I. TEE, F.E. X F.E. |
| 2 | RW GATE VALVE OR BUTTERFLY VALVE F.E. X F.E., WHERE REQUIRED ON PLANS. |
| 3 | D.I. FLANGED COUPLING ADAPTER WITH 316 STAINLESS STEEL NUTS, BOLTS AND WASHERS. |
| 4 | EXISTING PVC PIPE. |
| 5 | D.I. ADAPTER, F.E. X P.O. |

NOTE:

1. WRAP ALL METALLIC PARTS WITH 8 MIL POLYETHYLENE ENCASEMENT PER IRWD STD. SPEC. SECTION 15056.

CUT-IN TEE FOR PVC

IRVINE RANCH WATER DISTRICT, ENGINEERING DEPARTMENT
 APPROVED BY:

 KEVIN L. BURTON R.M.E. M28832
 EXECUTIVE DIRECTOR, TECHNICAL SERVICES

FEBRUARY 2025
 REVISION

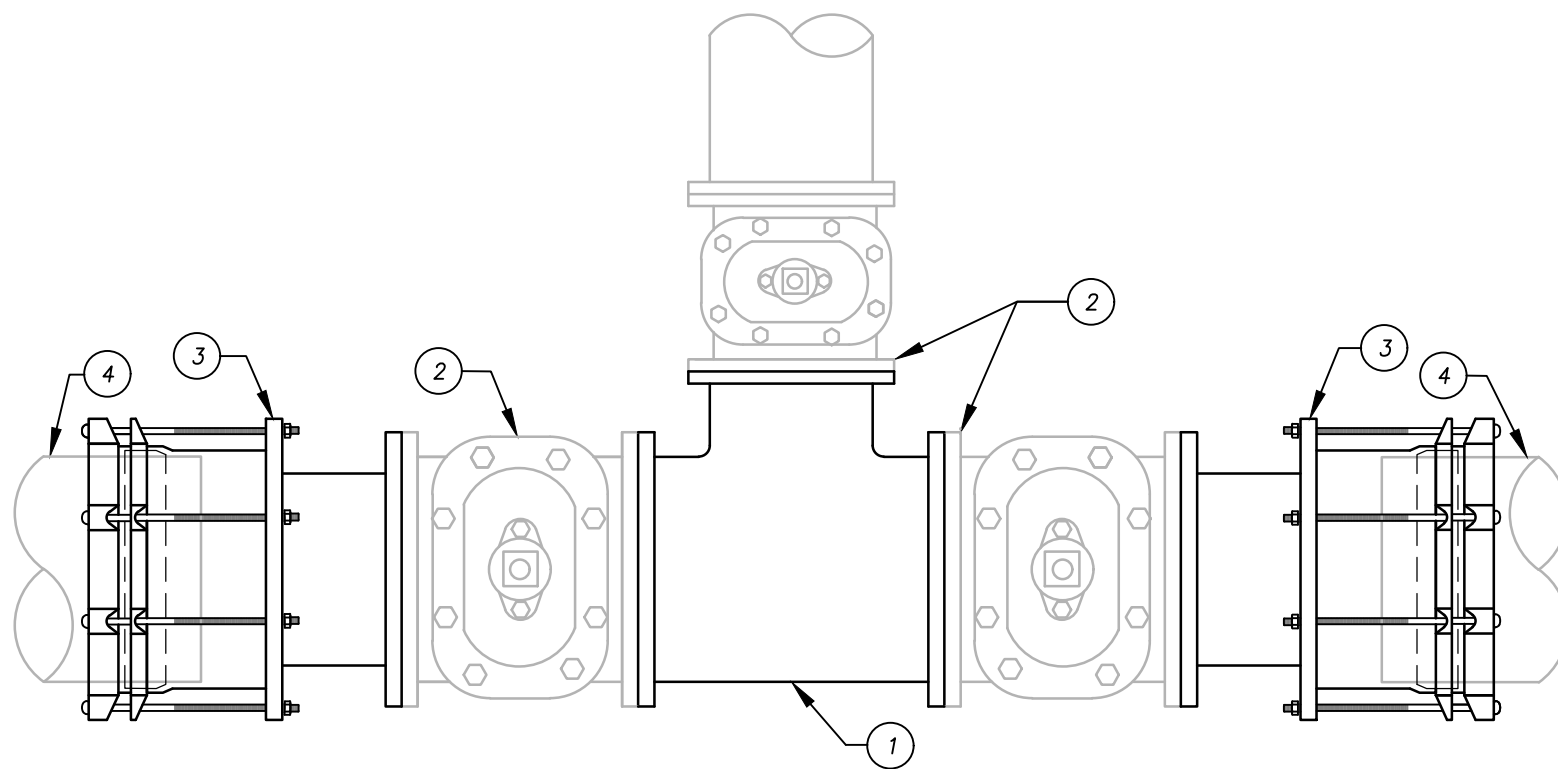

IRWD
 STD. DWG.
 W-19
 NOT TO SCALE
 SHEET 1 OF 3



WITH VALVES

ITEM MATERIALS

- ① — D.I. TEE, F.E. X F.E.
- ② — RW GATE VALVE OR BUTTERFLY VALVE, F.E. X F.E.
- ③ — D.I. FLANGED COUPLING ADAPTER WITH 316 STAINLESS STEEL NUTS, BOLTS AND WASHERS.
- ④ — EXISTING DIP.

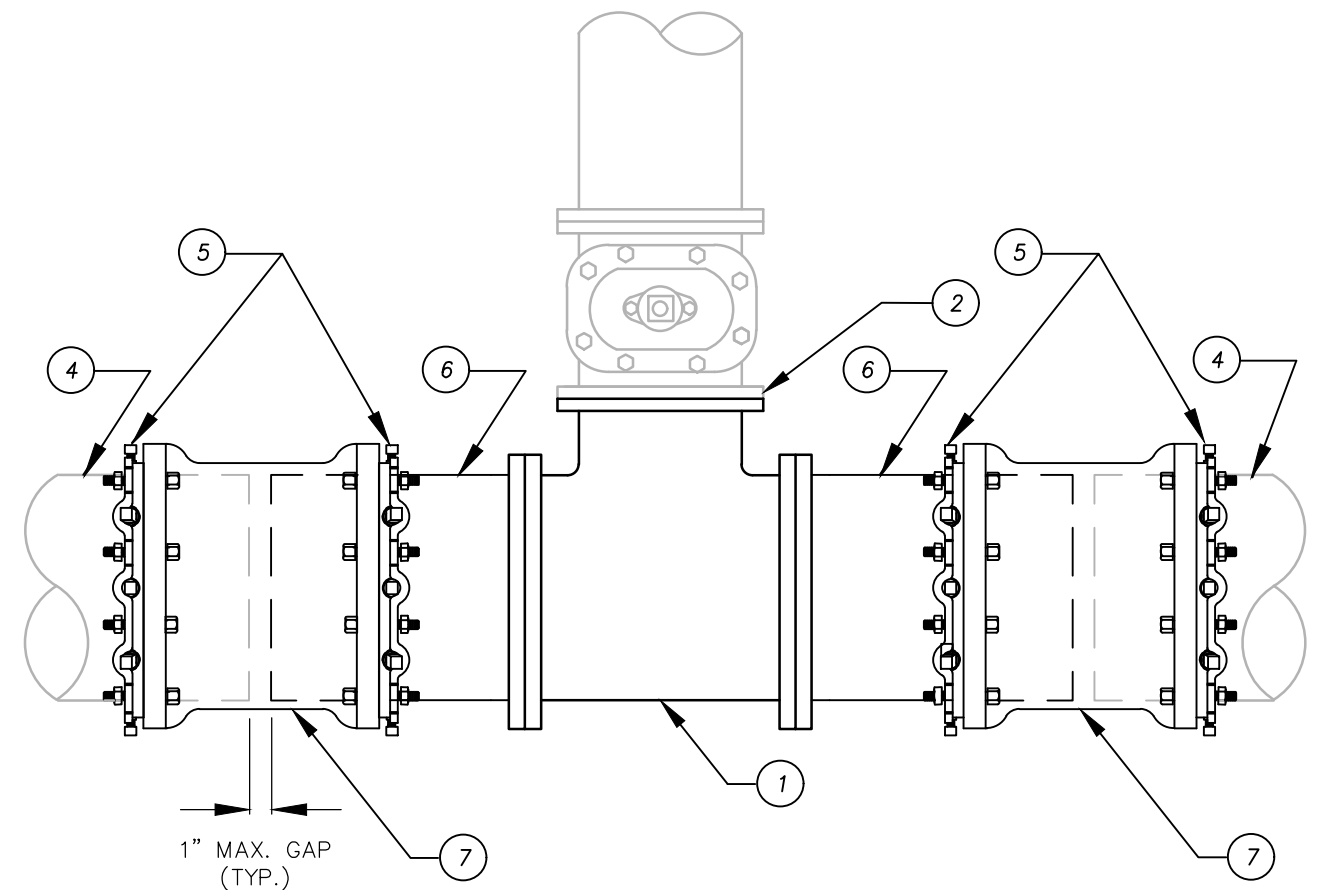

WITHOUT VALVES

ITEM MATERIALS

- ⑤ — MECHANICAL JOINT RETAINER GLAND AND 316 STAINLESS STEEL T-BOLTS, NUTS AND WASHERS.
- ⑥ — D.I. PIPE, CLASS 52 (LENGTH = 24").
- ⑦ — SOLID D.I. MECHANICAL JOINT SLEEVE.

NOTE:

1. WRAP ALL METALLIC PARTS WITH 8 MIL. POLYETHYLENE ENCASMENT PER IRWD STD. SPEC. SECTION 15056.

CUT-IN TEE FOR DIP

IRVINE RANCH WATER DISTRICT, ENGINEERING DEPARTMENT

APPROVED BY:

KEVIN L. BURTON R.M.E. M28832
EXECUTIVE DIRECTOR, TECHNICAL SERVICES

FEBRUARY 2025
REVISION



Irvine Ranch
WATER DISTRICT

**IRWD
STD. DWG.
W-19**

NOT TO SCALE
SHEET 2 OF 3

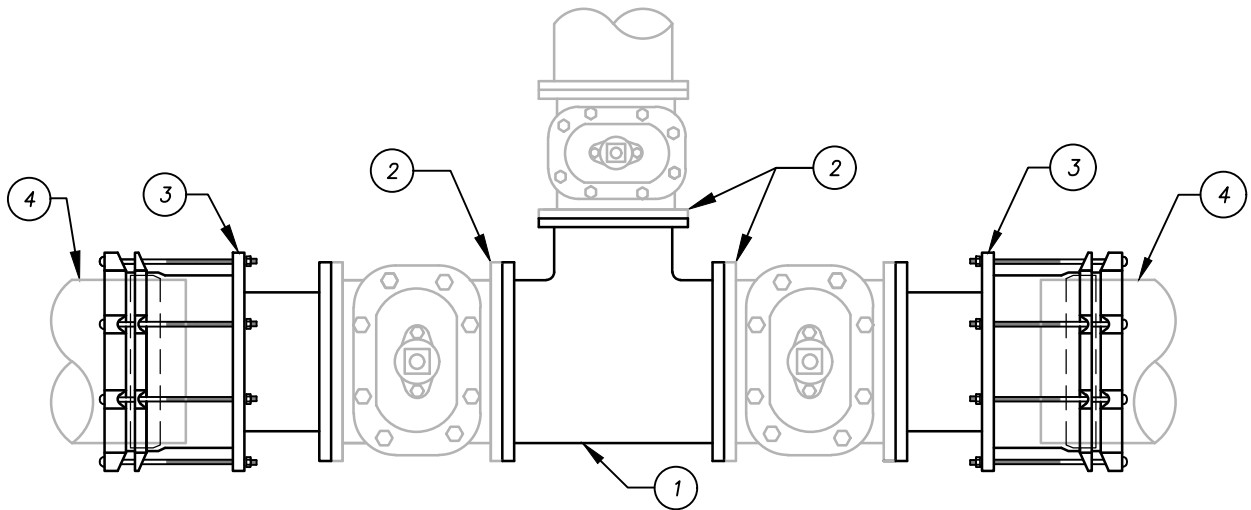

ITEM MATERIALS

- ① — D.I. TEE, F.E. X F.E.
- ② — RW GATE VALVE OR BUTTERFLY VALVE, F.E. X F.E.
- ③ — D.I. FLANGED COUPLING ADAPTER WITH 316 STAINLESS STEEL NUTS, BOLTS AND WASHERS.
- ④ — EXISTING ACP.

NOTES:

1. CUT ANY MACHINE-END OFF ACP TO EXISTING ROUGH BARREL.
2. WRAP ALL METALLIC PARTS WITH 8 MIL. POLYETHYLENE ENCASUREMENT PER IRWD STD. SPEC. SECTION 15056.

CUT-IN TEE FOR ACP

IRVINE RANCH WATER DISTRICT, ENGINEERING DEPARTMENT

APPROVED BY:

KEVIN L. BURTON R.M.E. M28832
EXECUTIVE DIRECTOR, TECHNICAL SERVICES

FEBRUARY 2025
REVISION



Irvine Ranch
WATER DISTRICT

**IRWD
STD. DWG.
W-19**

NOT TO SCALE
SHEET 3 OF 3

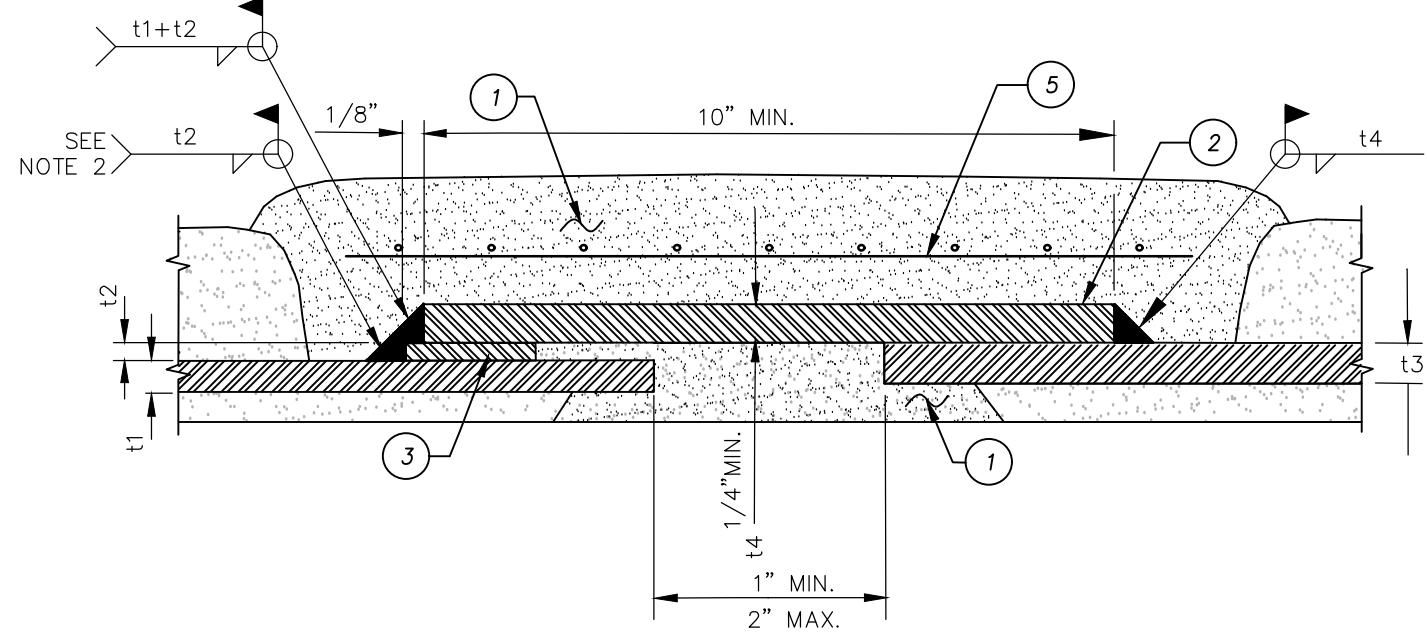

WELDED COLLAR JOINT

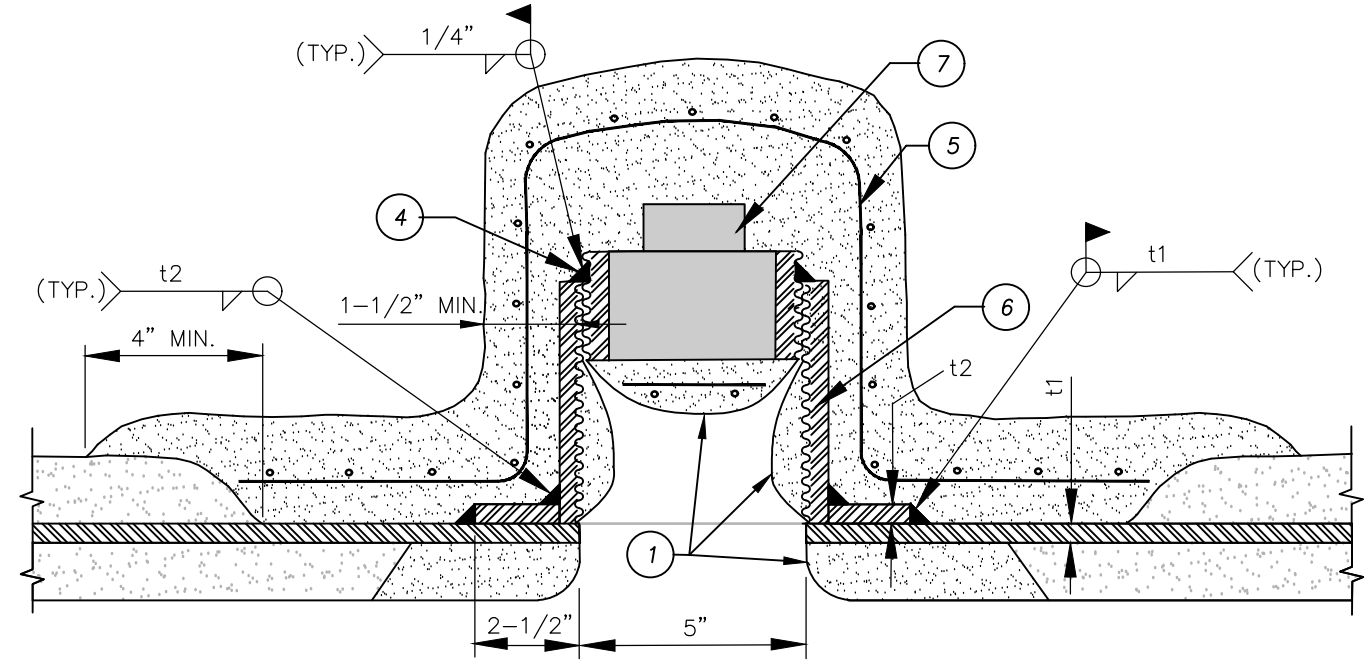

HANDHOLE

ITEM MATERIALS

- 1 — FIELD APPLIED CEMENT MORTAR.
- 2 — 10" MIN. WIDTH ROLLED STEEL BUTTSTRAP 2-PIECE COLLAR. MIN. PLATE THICKNESS OF 1/4" OR THINNEST PIPE WALL THICKNESS (t1 OR t3) BEING JOINED, WHICHEVER IS GREATER. CENTER BUTTSTRAP COLLAR OVER PIPE JOINT.
- 3 — FILLER BAR (WHERE NECESSARY) TO FILL GAP BETWEEN PIPE WALL AND WELD COLLAR. SEE GENERAL NOTES 1 AND 2. ROLL TO MATCH PIPE RADIUS.
- 4 — WELD PLUG TO COUPLING ENTIRE CIRCUMFERENCE.
- 5 — 2" X 2" W.W.M. 12 GAUGE BOTH WAYS.
- 6 — 5" EXTRA HEAVY STEEL COUPLING.
- 7 — HEAVY SOLID STEEL THREADED PLUG WITH 2" SQUARE DRIVING NUT, TIGHTEN PLUG INTO THREADED COUPLING. LEAVE SEVERAL THREADS EXPOSED TO ALLOW PROPER WELD SURFACE. TACK WELD PIECE OF WELD WIRE MESH TO BOTTOM TO FACILITATE FIELD APPLIED CEMENT MORTAR.

HANDHOLE NOTES:

- 1. ONE HANDHOLE IS REQUIRED FOR PIPE DIA. 16" OR LESS. SEE BELOW FOR ORIENTATION.
- 2. TWO HANDHOLES ARE REQUIRED FOR PIPE DIA. 18" TO 24". SEE BELOW FOR ORIENTATION.
- 3. FOUR HANDHOLES ARE REQUIRED FOR PIPE DIA. 30" AND LARGER. SEE BELOW FOR ORIENTATION.

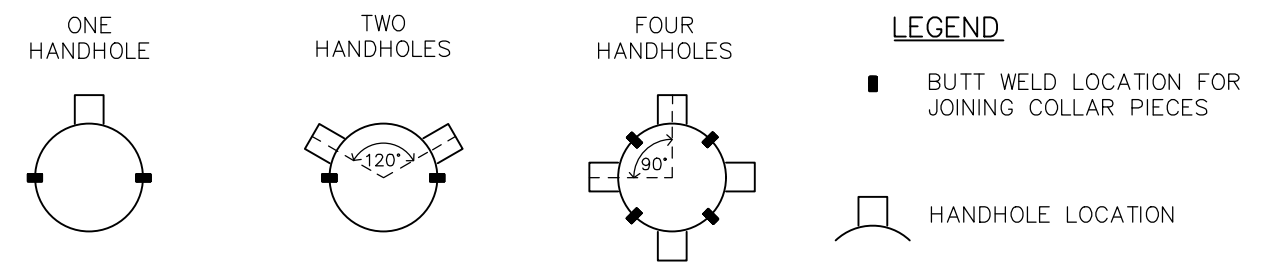

GENERAL NOTES:

- 1. ROLLED STEEL WELD COLLARS ("BUTT STRAPS") SHALL NOT BE HEATED OR HAMMERED TO FIT O.D. OF SMALLER PIPE. USE FILLER BAR AS SHOWN, WHERE NECESSARY.
- 2. WELD IS REQUIRED ONLY WHERE FILLER BAR IS USED.
- 3. FOR 24" DIA. AND LARGER, GROUT ALL HAND-HOLE OPENINGS FULL OF GROUT AND FINISH FLUSH AND CURVED TO MIMICK FACTORY CEMENT MORTAR LINING.

MORTAR LINED AND COATED STEEL PIPE JOINTS		
IRVINE RANCH WATER DISTRICT, ENGINEERING DEPARTMENT		
APPROVED BY: KEVIN L. BURTON R.M.E. M28832 EXECUTIVE DIRECTOR, TECHNICAL SERVICES	FEBRUARY 2025 REVISION	 IRWD STD. DWG. W-20 NOT TO SCALE SHEET 1 OF 2

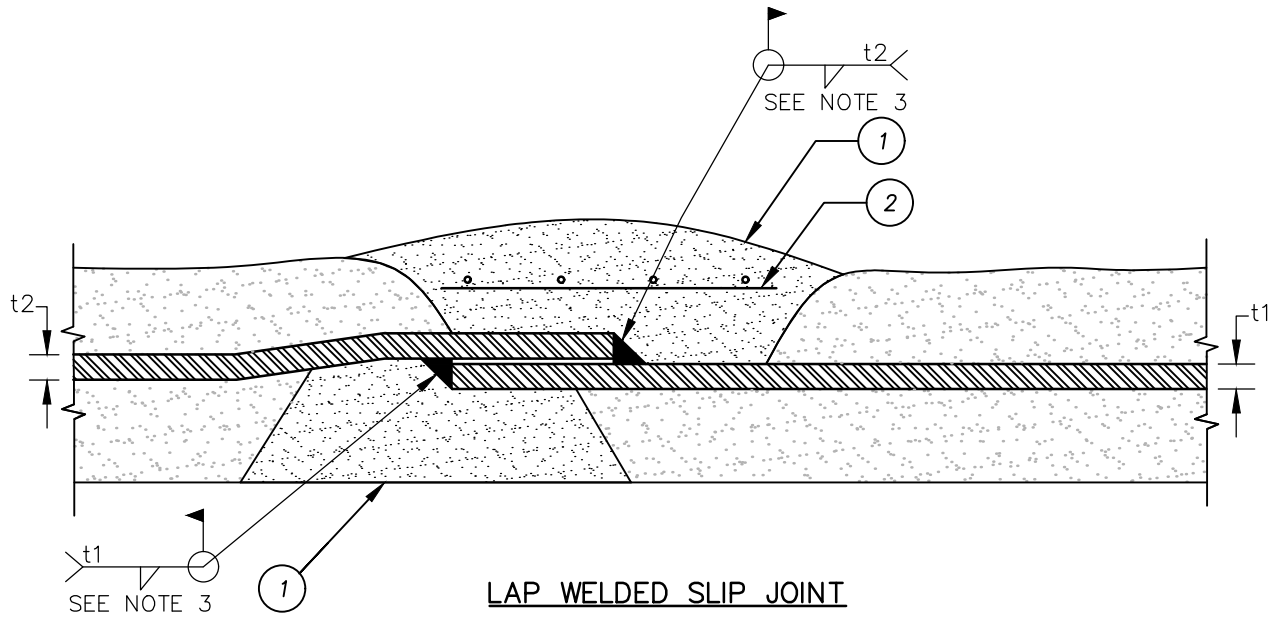

ITEM MATERIALS

- ① — FIELD APPLIED CEMENT MORTAR.
- ② — 2" X 2" W.W.M. 12 GAUGE BOTH WAYS.

NOTES:

1. SEE IRWD STD. SPEC. SECTION 15076 FOR STEEL PIPE SHELL THICKNESS AND MORTAR LINING AND COATING THICKNESS.
2. APPLY WELD MATERIAL WITH A MIN. OF TWO WELD PASSES FOR EACH WELD JOINT FOR PIPE DIA. LESS THAN 36". USE A MIN. OF THREE WELD PASSES FOR PIPE DIA. 36" AND LARGER.
3. PIPE DIA. < 24": OUTSIDE WELD REQUIRED.
 PIPE DIA. 24" – 30": INSIDE WELD OR OUTSIDE WELD, AT CONTRACTORS OPTION.
 PIPE DIA. > 30": INSIDE WELD REQUIRED.
4. WHERE $t_2 \neq t_1$, WELD DIMENSION SHALL BE EQUAL TO THE THICKEST PIPE WALL.

MORTAR LINED AND COATED STEEL PIPE JOINTS

IRVINE RANCH WATER DISTRICT, ENGINEERING DEPARTMENT

APPROVED BY:

Kevin L. Burton
 KEVIN L. BURTON R.M.E. M28832
 EXECUTIVE DIRECTOR, TECHNICAL SERVICES

FEBRUARY 2025
 REVISION



**IRWD
 STD. DWG.
 W-20**

NOT TO SCALE
 SHEET 2 OF 2

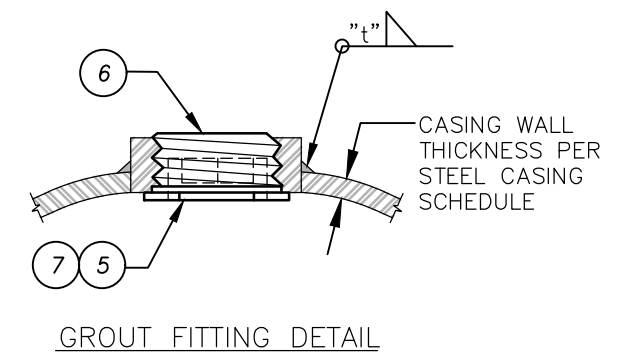
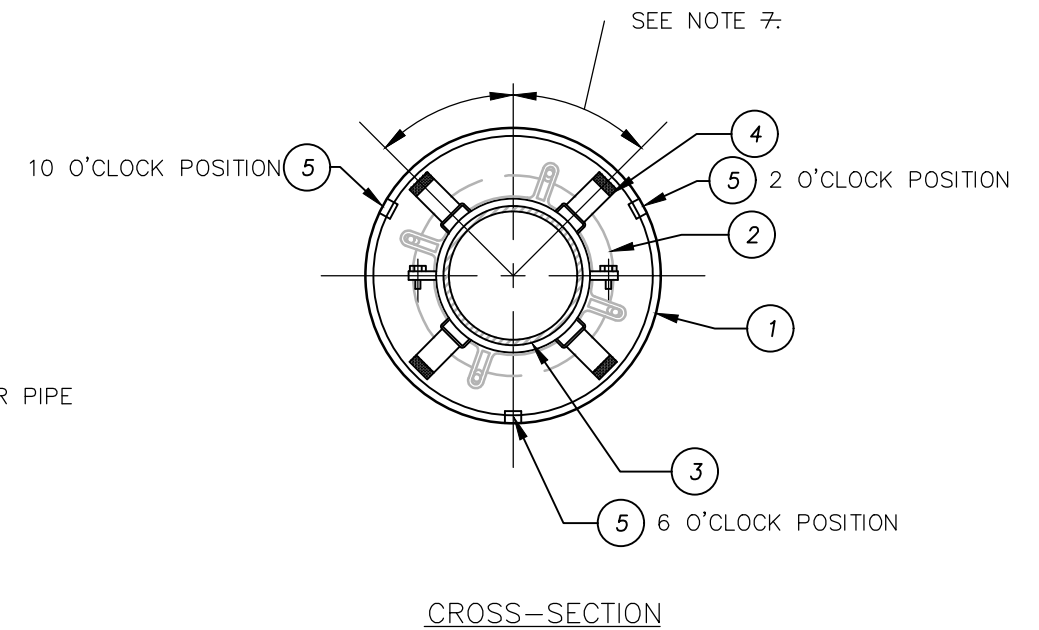
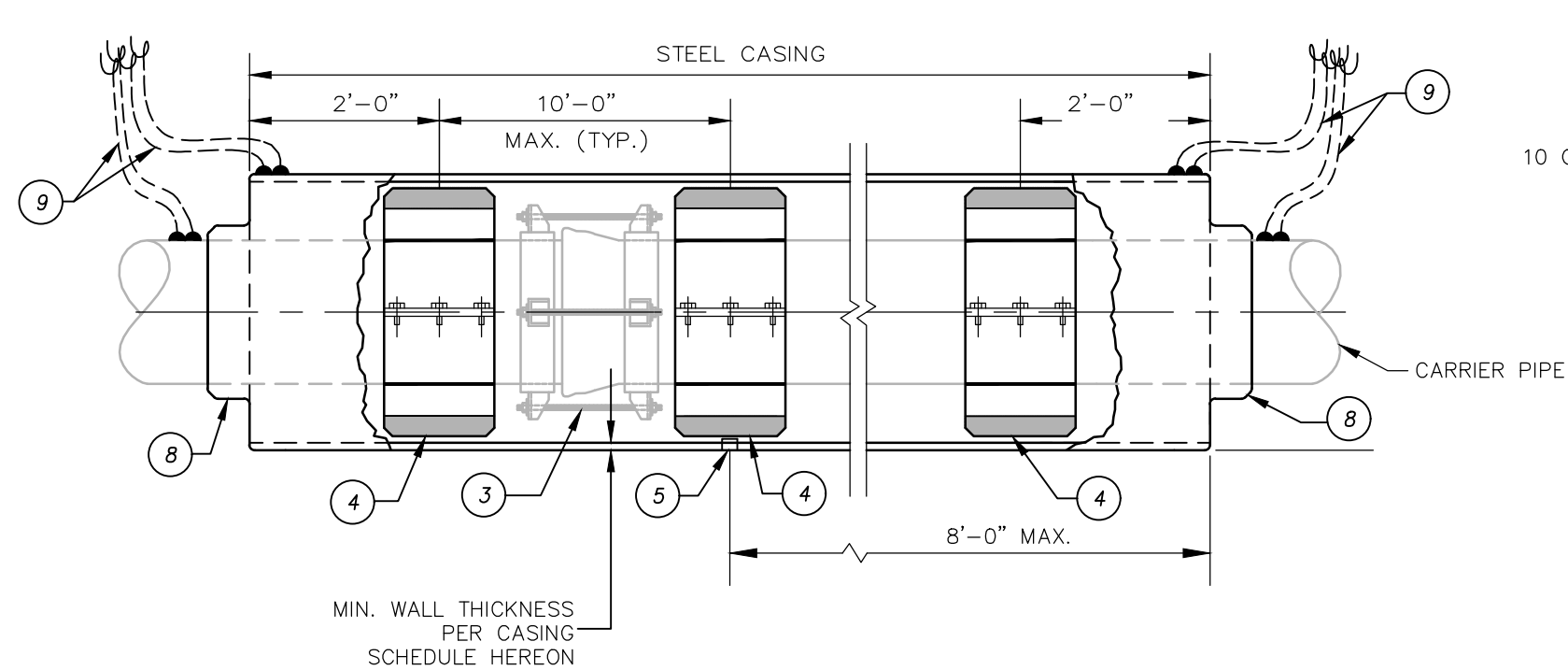

ITEM	MATERIALS
1	STEEL CASING PER IRWD STD. SPEC. SECTION 02315.
2	CARRIER PIPE JOINT BELL, BEYOND.
3	CARRIER PIPE WITH ALL JOINTS RESTRAINED.
4	STAINLESS STEEL CASING SPACERS WITH UHMW POLYETHYLENE RUNNERS PER IRWD STD. SPEC. SECTION 02315.
5	GROUT FITTING @ 8' O.C. PER DETAIL HEREON. FOR ALL CASINGS 30" IN DIA. AND LARGER, INSTALL ONE COUPLING IN 6 O'CLOCK POSITION @ 8' O.C.; STAGGER COUPLINGS BETWEEN 10 O'CLOCK AND 2 O'CLOCK POSITIONS EVERY 4 LINEAR FEET ALONG CASING AXIS.
6	2" NPT THREADED STEEL PLUG.
7	2" NPT STANDARD WEIGHT STEEL PIPE HALF COUPLING.
8	EPDM CASING END SEAL PER IRWD SPEC. SECTION 02315 WITH STAINLESS STEEL WORM-SCREW BAND CLAMPS.
9	CASING TEST STATION PER IRWD STD. DWG. CP-3 (OMIT 2 WIRES FOR NON-METALLIC CARRIER PIPE).

NOTES:

- CASING SHALL BE INSTALLED BY THE BORE, JACK AND/OR TUNNEL METHOD, OR OPEN TRENCH. SEE IRWD STD. SPEC. SECTIONS 02315 AND 02316. BEDDING MATERIAL FOR OPEN TRENCH CASING INSTALLATION SHALL CONSIST OF 6" OF 3/4" CRUSHED ROCK.
- SIZE AND THICKNESS OF CASING SHALL BE AS SHOWN IN STEEL CASING SCHEDULE HEREON. FOR LONG BORES OR SPECIAL SITUATIONS GREATER WALL THICKNESS THAN SHOWN IN SCHEDULE MAY BE REQUIRED.
- ALL STEEL CASING PIPE FIELD JOINTS SHALL BE WELDED FULL-CIRCUMFERENCE.
- CARRIER PIPE SHALL BE PRESSURE TESTED PRIOR TO SEALING ENDS OF CASING.
- EACH END OF CASING SHALL BE SEALED WITH APPROVED RUBBER CASING END SEALS.
- BACKFILL FOR CASING IN OPEN CUT SHALL BE PER IRWD STD. DWG. W-17.
- NUMBER AND PLACEMENT OF SPACERS ON CARRIER PIPE PER MANUFACTURER'S SPECIFICATIONS.
- ALL CARRIER PIPE JOINTS INSIDE THE STEEL CASING AND A MIN. 5' OUTSIDE THE STEEL CASING SHALL BE RESTRAINED.
- CATHODIC PROTECTION REQUIRED FOR STEEL CASING 40 FEET IN LENGTH AND LONGER ONLY.
- REFER TO TABLE IN IRWD STD. SPEC. SECTION 02315 AND 02316 FOR ANNULAR SPACE FILL REQUIREMENTS.

STEEL CASING SCHEDULE		
NOMINAL CARRIER PIPE SIZE	MINIMUM CASING SIZE (NOMINAL)	MINIMUM WALL THICKNESS
4"	12"	1/4"
6"	16"	5/16"
8"	18"	5/16"
10"	20"	5/16"
12"	24"	3/8"
14"	27"	3/8"
16"	30"	3/8"
18"	30"	1/2"
20"	36"	1/2"
24"	42"	1/2"

STEEL CASING FOR WATER PIPE

IRVINE RANCH WATER DISTRICT, ENGINEERING DEPARTMENT

APPROVED BY:

Kevin L. Burton

KEVIN L. BURTON R.M.E. M28832
EXECUTIVE DIRECTOR, TECHNICAL SERVICES

FEBRUARY 2025
REVISION



Irvine Ranch
WATER DISTRICT

IRWD
STD. DWG.
W-21

NOT TO SCALE
SHEET 1 OF 1

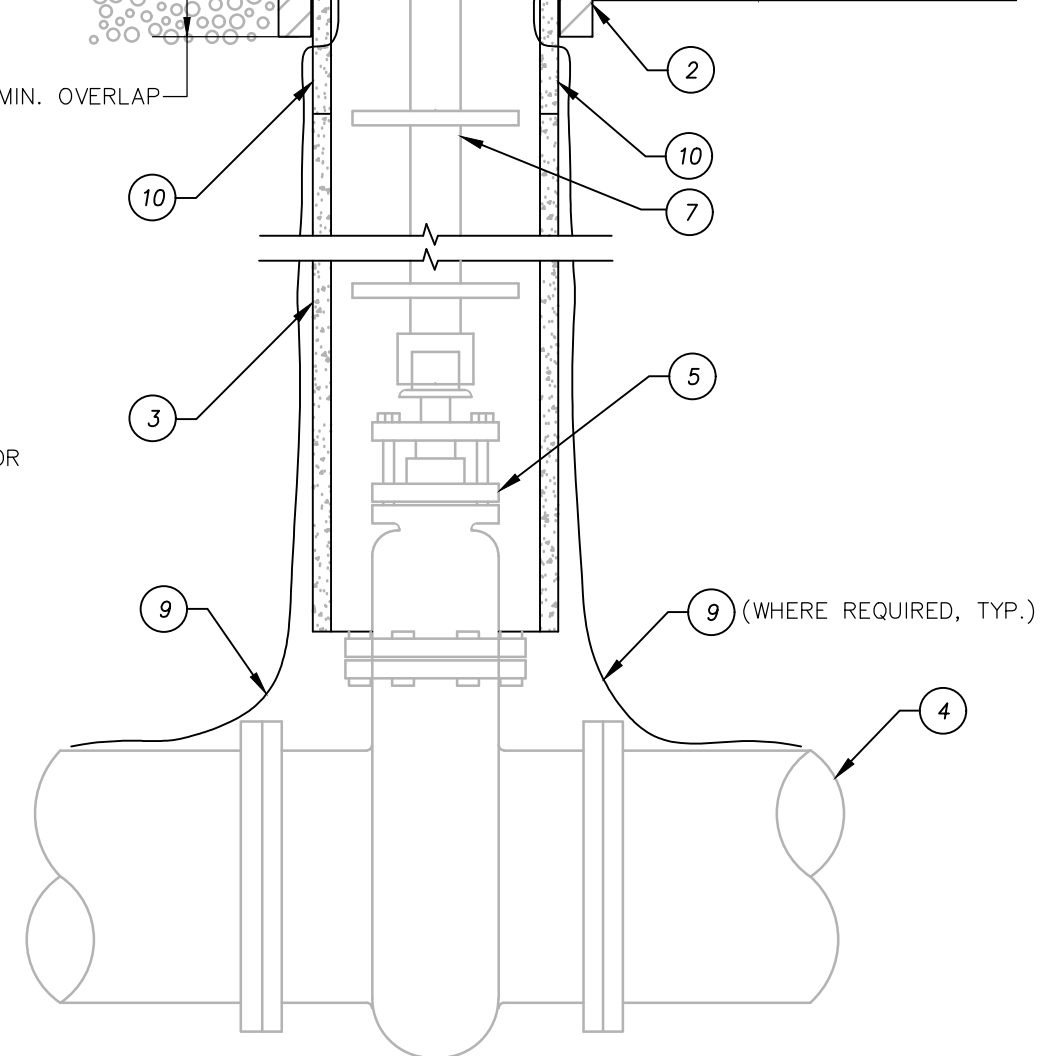
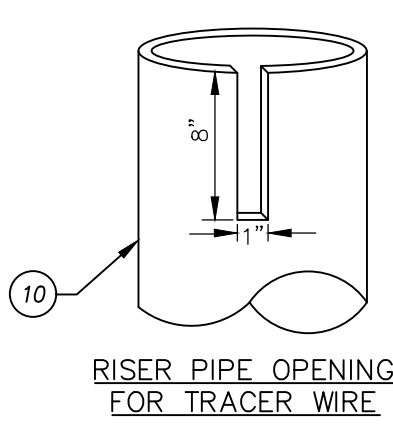
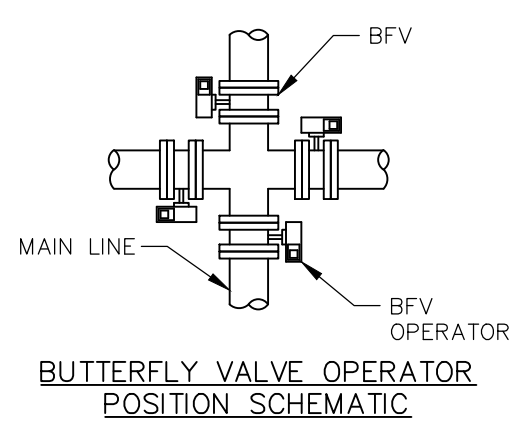
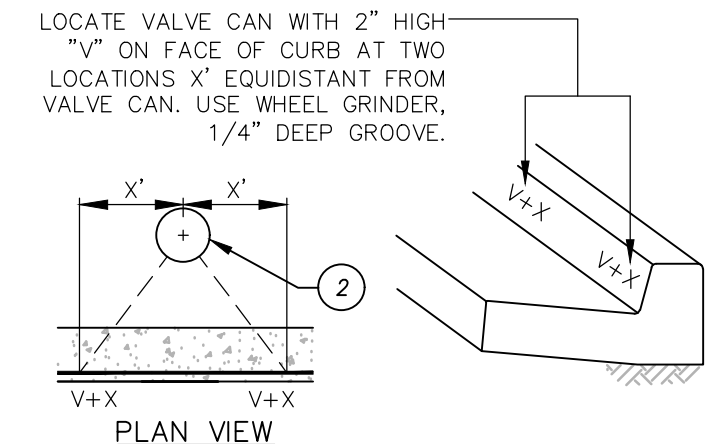
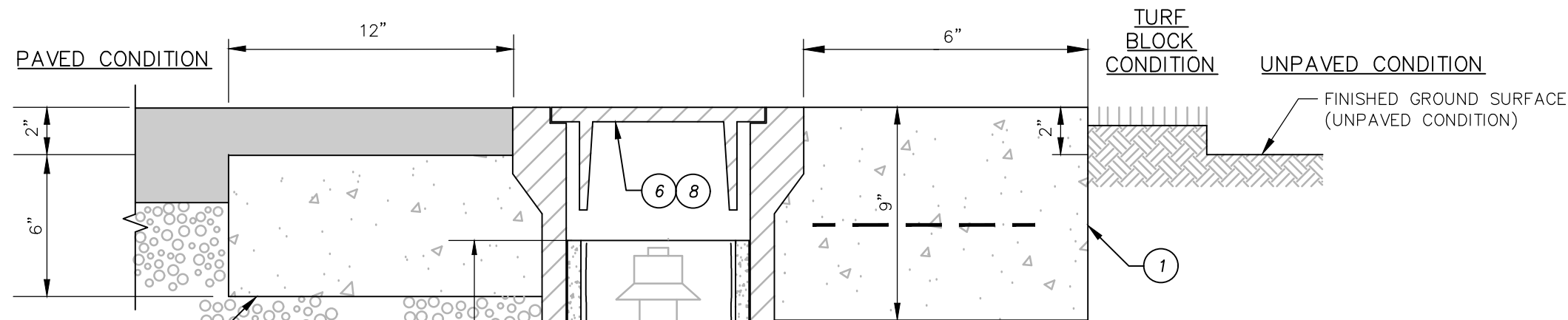

- | ITEM | MATERIALS |
|------|--|
| 1 | CLASS "B" CONCRETE COLLAR. REINFORCE WITH W.W.F. 1.6 X 1.6 IN TURF BLOCK AND UNPAVED CONDITIONS. |
| 2 | VALVE BOX AND FRAME PER IRWD STD. SPEC. SECTION 15100. |
| 3 | ONE-PIECE 8" (SDR 35) PVC RISER PIPE. |
| 4 | MAIN LINE. |
| 5 | VALVE. BUTTERFLY OR GATE. SEE BFV OPERATOR POSITION SCHEMATIC HEREON FOR OPERATOR POSITIONS ALONG THE PIPELINE. |
| 6 | VALVE COVER TO BE IRON WITH LETTERS "IRWD" CAST THEREON. FOR DOMESTIC WATER LINES ADD "WATER", FOR RECYCLED WATER LINES ADD "RW", FOR RAW WATER SUPPLY LINES ADD "RAW", FOR BRINE WASTE LINES ADD "BRINE". |
| 7 | VALVE STEM EXTENSION PER IRWD STD. DWG. W-23. SEE NOTE 1. |
| 8 | VALVE COVER PER DETAIL HEREON. USE LONG-SKIRTED CAST IRON LID FOR ROUND BOXES. |
| 9 | TRACER WIRE WHERE REQUIRED ON PLANS. INSTALL AND TEST PER IRWD STD. DWG. W-17 AND IRWD STD. SPEC. SECTION 15151. TAPE TRACER WIRE TO PIPE AT 2' INTERVALS USING 2" WIDE 10-MIL TAPE. |
| 10 | RISER PIPE OPENING FOR TRACER WIRE. |

- NOTES:**
1. PROVIDE VALVE STEM EXTENSION IF DEPTH TO VALVE NUT EXCEEDS 84". SEE IRWD STD. DWG. W-23.
 2. SET TRIANGULAR COVERS SUCH THAT APEX OR TRIANGLE POINT ALONG AXIS OF PIPE, AWAY FROM NEAREST FITTING.
 3. SEE IRWD STD. SPEC. SECTION 15100 FOR VALVE BOX REQUIREMENTS.
 4. TIE DOWN ALL VALVE CANS ON THE NEAREST CURB FACE BY MEANS OF A 4-INCH WHEEL GRINDER, SEE DETAIL ABOVE.
 5. EXISTING VALVE CANS AND LIDS RAISED TO GRADE SHALL BE REMOVED AND REPLACED WITH NEW, SET, AND PAINTED PER IRWD STD. SPEC. SECTION 15100.
 6. VALVE BOX MUST BE CONSTRUCTED AS SHOWN HEREON REGARDLESS OF CONSTRUCTION PHASE. NO INTERIM CONDITIONS WILL BE ACCEPTED.
 7. VALVE AND VALVE BOX SHALL NOT BE LOCATED WITHIN A SIDEWALK UNDER ANY CONDITION.
 8. STREET REHABILITATION AND/OR ASPHALT OVERLAY PROJECTS SHALL NOT INTERRUPT THE SERVICE FUNCTION OF ANY VALVES AND EMERGENCY ACCESS SHALL BE MAINTAINED AT ALL TIMES. VALVES THAT ARE PAVED OVER DURING CONSTRUCTION SHALL BE RAISED TO GRADE NO LATER THAN THREE DAYS AFTER THEY WERE PAVED OVER.

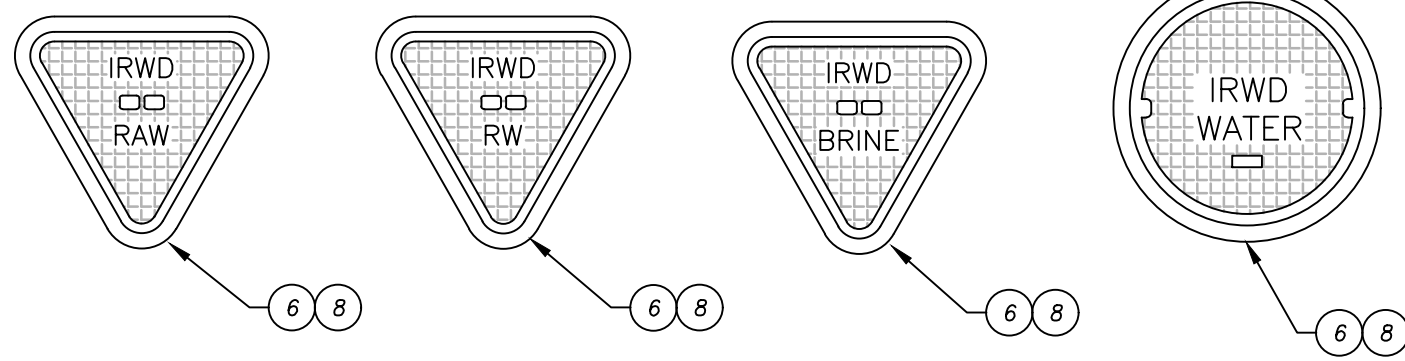

VALVE BOX			IRWD STD. DWG. W-22
IRVINE RANCH WATER DISTRICT, ENGINEERING DEPARTMENT APPROVED BY: KEVIN L. BURTON R.M.E. M28832 EXECUTIVE DIRECTOR, TECHNICAL SERVICES			

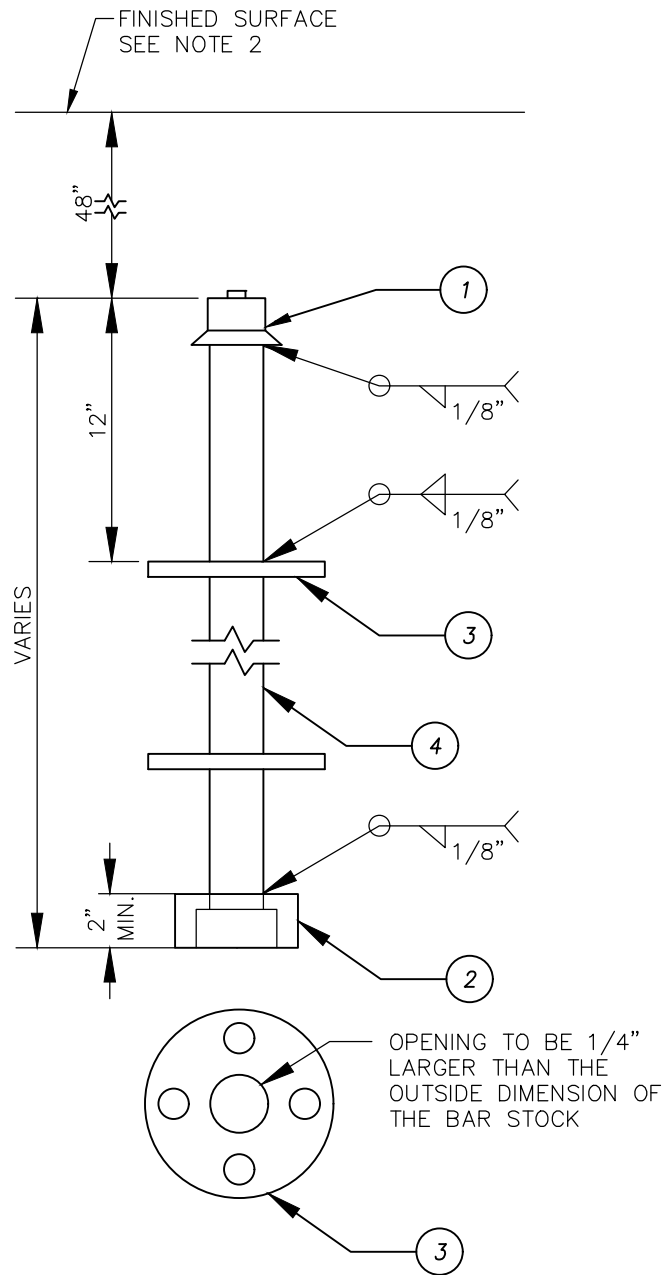

ITEM MATERIALS

- 1 — A.W.W.A. 2" SQUARE OPERATING NUT.
- 2 — A.W.W.A. SOCKET FOR 2" SQUARE OPERATING NUT.
- 3 — 6-1/2" DIA. X 3/16" SPACER PLATE.
- 4 — 1-1/4" SOLID, ROUND OR SQUARE, STEEL BAR STOCK (PINNED COUPLERS ARE NOT ALLOWED, HOLLOW TUBE OR PIPE ARE NOT ALLOWED).

NOTES:

1. PROVIDE VALVE STEM EXTENSION WHEN DEPTH TO OPERATING NUT EXCEEDS 84" (FABRICATE EXTENSION TO FIELD MEASUREMENT, SEE NOTE 2).
2. TERMINATE EXTENSION 48" FROM FINISHED SURFACE.
3. PROVIDE ADDITIONAL SPACER PLATE(S) WHEN DISTANCE TO BOTTOM SOCKET EXCEEDS 60" BEYOND LOWEST PLATE.

VALVE STEM EXTENSION

IRVINE RANCH WATER DISTRICT, ENGINEERING DEPARTMENT

APPROVED BY:

KEVIN L. BURTON R.M.E. M28832
EXECUTIVE DIRECTOR, TECHNICAL SERVICES

FEBRUARY 2025
REVISION



Irvine Ranch
WATER DISTRICT

IRWD
STD. DWG.
W-23

NOT TO SCALE
SHEET 1 OF 1

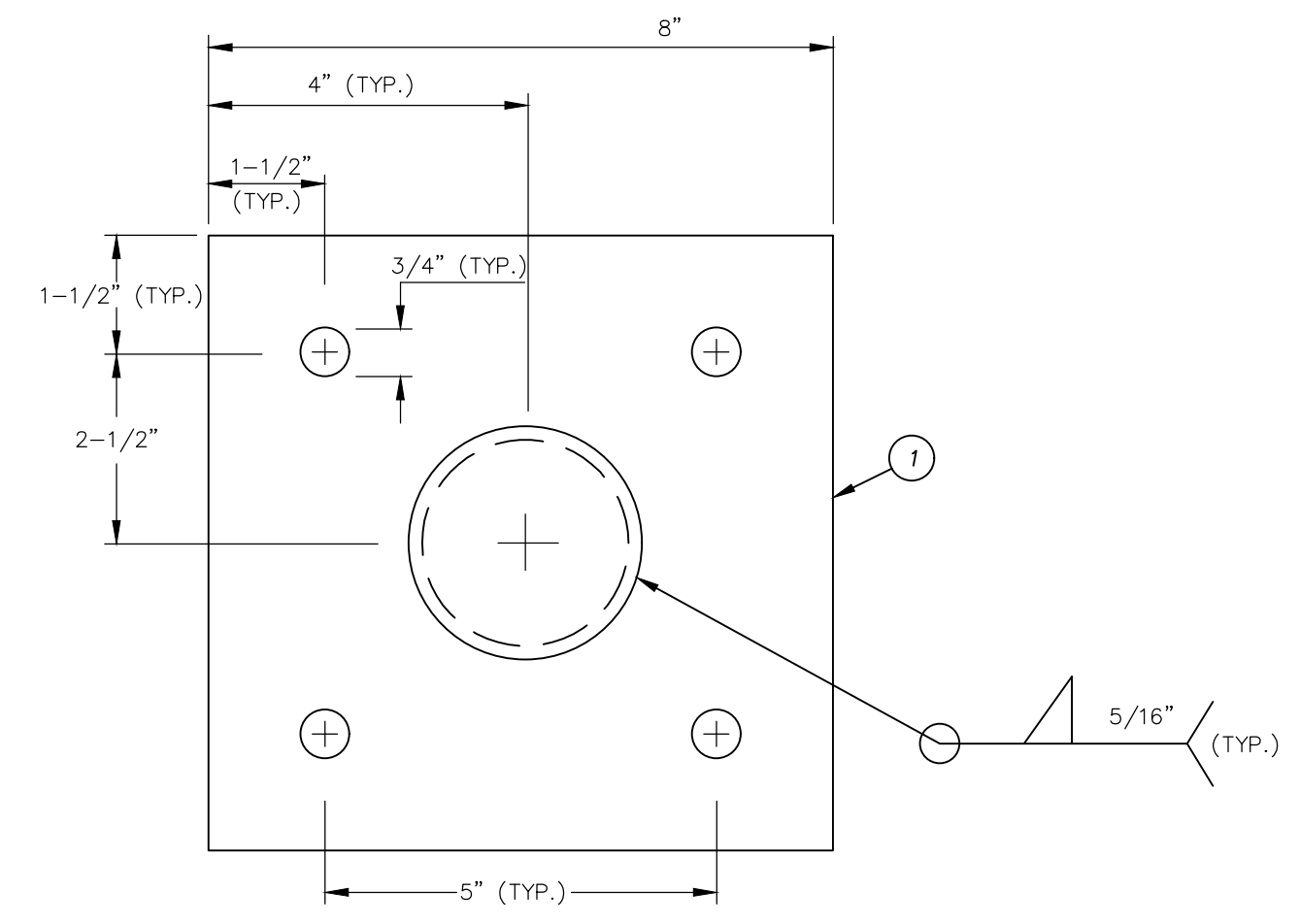
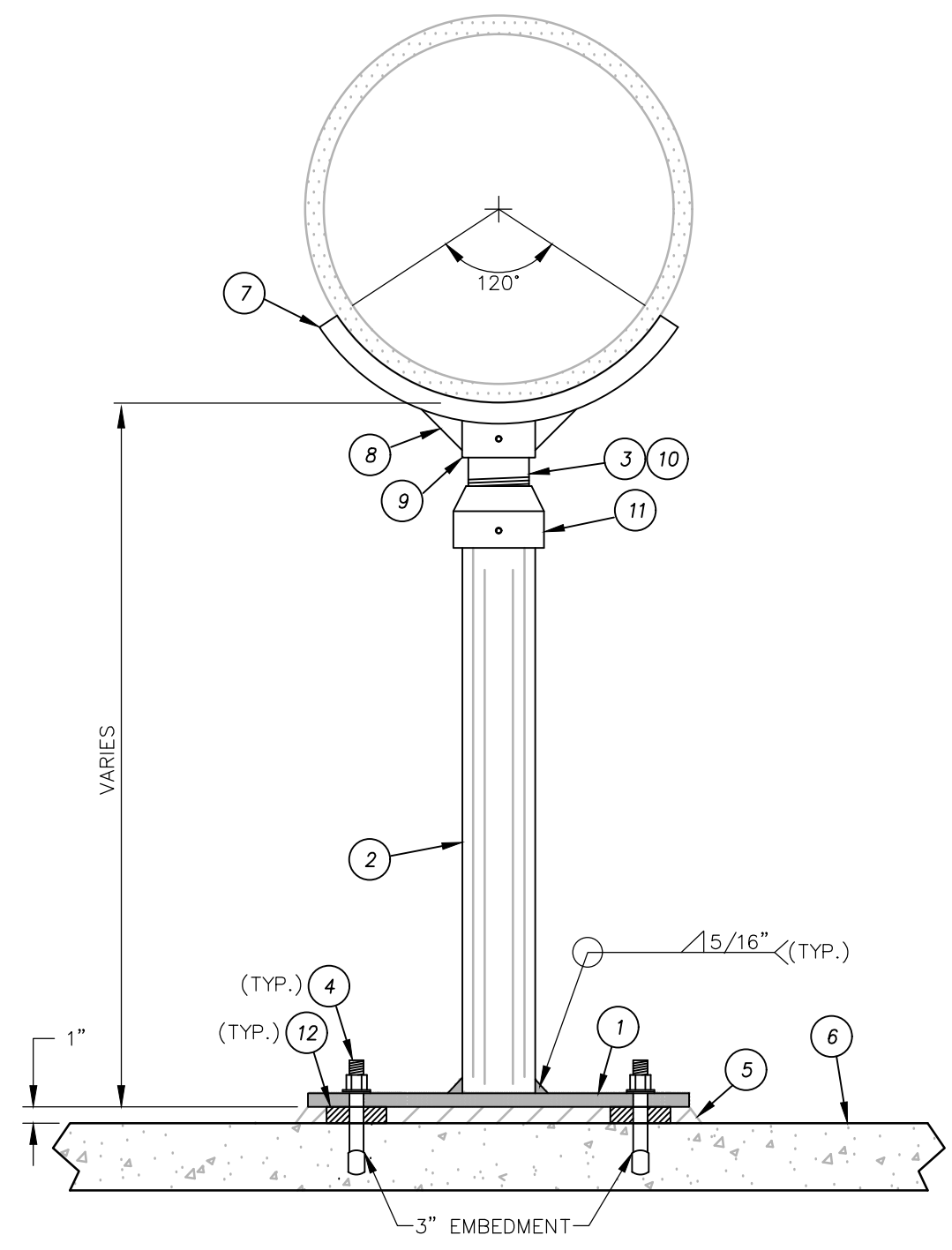

- | ITEM | MATERIALS |
|------|--|
| 1 | 8" X 8" X 1/2" BLACK STEEL BASE PLATE WITH (4) 3/4" DIA. BOLT HOLES. |
| 2 | 3" DIA. SCH 40 BLACK STEEL PIPE WELDED TO BASE PLATE, STOCKED @ 15" LONG TO BE CUT TO SIZE IN THE FIELD. |
| 3 | COAT THREADS WITH LIBERAL AMOUNTS OF ANTI-SEIZE COMPOUND. |
| 4 | 5/8" DIA. RED HEAD STAINLESS STEEL CONCRETE ANCHOR BOLT WITH 5/8" DIA. STAINLESS STEEL HEX HEAD ANCHOR NUT AND 1" X 5/8" HEAVY STAINLESS STEEL WASHER. DRILL AND MOUNT INTO CONCRETE PAD OR VAULT FLOOR. |
| 5 | 1" THICK NON-SHRINK GROUT LEVELING COURSE. |
| 6 | CONCRETE PAD OR VAULT FLOOR. |
| 7 | 3/8" THICK X 4" WIDE STAINLESS STEEL SADDLE ASSEMBLY. PRE-COAT WITH POLYURETHANE SPRAY COATING. 40 MILS THICK. TOP AND SIDE SURFACES ONLY. SADDLE ROLLED TO MATCH RADIUS OF PIPE. |
| 8 | 3/8" THICK STAINLESS STEEL GUSSET PLATE. |
| 9 | 3" DIA. SCH 80 STAINLESS STEEL RECEIVER TUBE WITH 1/2" STAINLESS STEEL ALLEN SET SCREW. |
| 10 | 2-1/2" DIA. SCH 40 STAINLESS STEEL THREADED RISER, PROVIDES APPROXIMATELY 6" OF ADJUSTMENT. |
| 11 | 3" DIA. STAINLESS STEEL HEAVY THREADED ADJUSTMENT COUPLING WITH 1/2" DIA. STAINLESS STEEL SET SCREW. |
| 12 | 1" STAINLESS STEEL SPACER. |

NOTE:

1. ALL PIPE SUPPORT COMPONENTS SHALL BE HOT DIP GALVANIZED AFTER FABRICATION, WITH THE EXCEPTION OF THE SADDLE AND THREADED STAINLESS STEEL PARTS.

PIPE SUPPORT			IRWD STD. DWG. W-24
IRVINE RANCH WATER DISTRICT, ENGINEERING DEPARTMENT APPROVED BY: KEVIN L. BURTON R.M.E. M28832 EXECUTIVE DIRECTOR, TECHNICAL SERVICES			

TABLE OF CONTENTS

Sewer Standard Drawings

NUMBER	DESCRIPTION	DATE
S-1	Manhole	Feb 2025
S-2	<Not Used>	
S-3	Sewer Lateral	Feb 2025
S-4	Cut-in Wye Connection	Feb 2025
S-5	Terminal Cleanout	Feb 2025
S-6	Sewer Trench	Feb 2025
S-7	Steel Casing for Sewer Pipe	Feb 2025

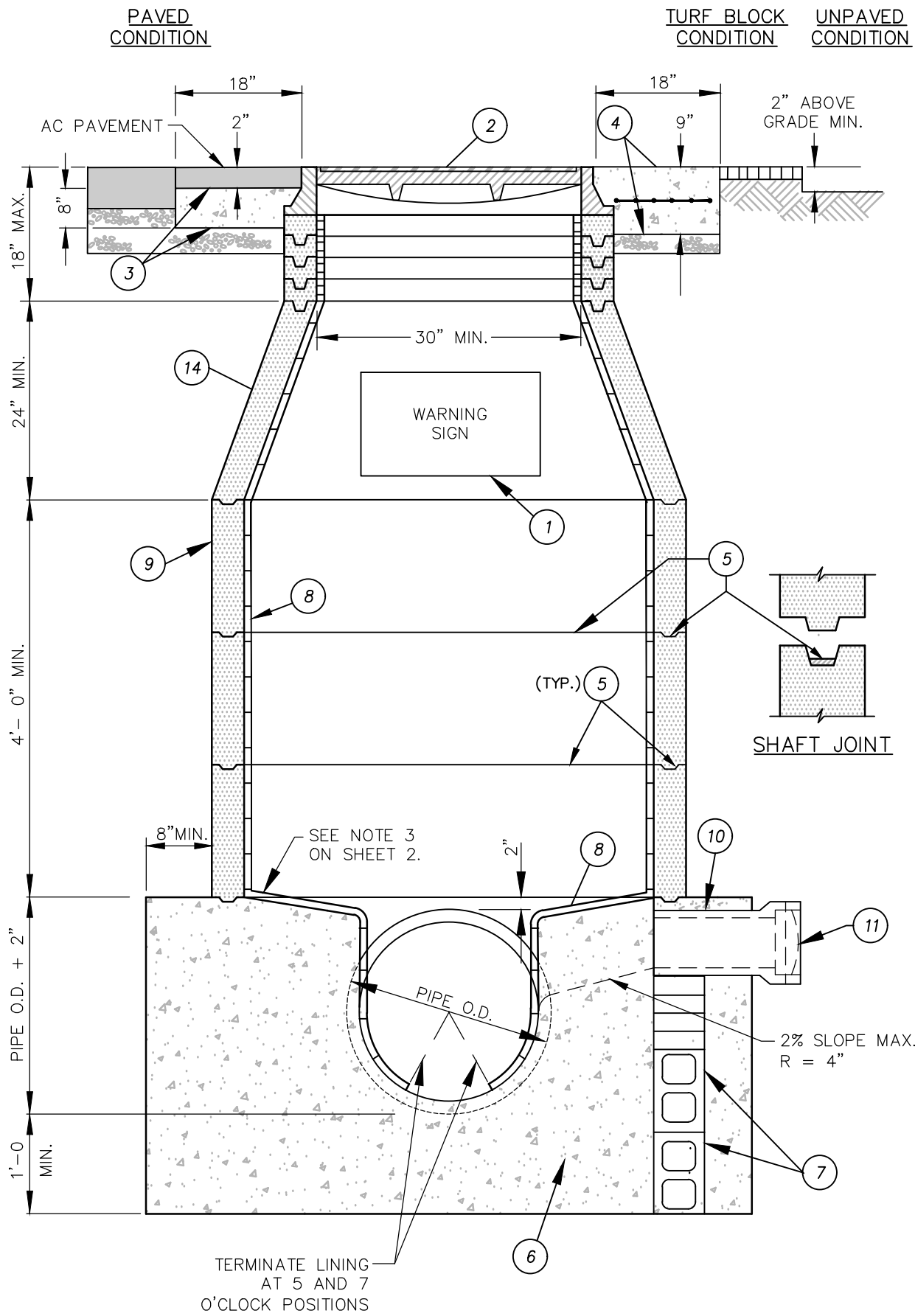

ELEVATION - MANHOLE

- | ITEM | MATERIALS |
|------|---|
| 1 | STENCILED WARNING SIGN WITH WHITE BACKING. SEE DETAIL ON SHEET 2. |
| 2 | FRAME AND COVER PER IRWD STD. SPEC. SECTION 03461. SEE DETAIL ON SHEET 2. |
| 3 | ROUND CLASS "B" CONCRETE COLLAR AND AC PAVEMENT. |
| 4 | SQUARE CLASS "B" CONCRETE PAD REINFORCE WITH 6" X 6" W.W.F. 10 GAUGE CENTERED IN CONCRETE. SEE SHEET 2 FOR CONCRETE PAD DIMENSIONS TABLE. |
| 5 | SHAFT JOINT WITH JOINT SEALING COMPOUND. SEE NOTE 8 ON SHEET 2. |
| 6 | CONCRETE MANHOLE BASE, CAST IN PLACE PER IRWD STD. SPEC. SECTION 03300. SEE NOTES 6 AND 8 ON SHEET 2. |
| 7 | CONCRETE BLOCK AND/OR BRICK SUPPORT. SEE NOTE 4 ON SHEET 2. |
| 8 | MANHOLE LINER (WHERE REQUIRED) PER IRWD STD. SPEC. SECTION 09900. APPLY NON-SKID SURFACE ON TOTAL SHELF AREA. |
| 9 | PRECAST CONCRETE MANHOLE SHAFT, MIN. WALL THICKNESS PER IRWD STD. SPEC. SECTION 03461. |
| 10 | INSTALL 16" LONG VCP THROUGH MANHOLE BASE FOLLOWED BY A 12" LONG VCP, AS SHOWN, FOR FLEXIBILITY. FOR PVC PIPE, REFER TO "PVC PIPE CONNECTION" DETAILS HEREON. |
| 11 | INSTALL TEMPORARY PLUG IN PIPE BELL-JOINT. |
| 12 | FOR SDR-35 PVC PIPE: GASKETED SDR-35 (SDR 26 FOR 15" THRU 18") PVC MANHOLE COUPLING WITH EPOXY RESIN SAND COATING ON EXTERIOR SURFACE. FOR C900 PVC DR 14 PIPE: GASKETED C900 PVC DR 14 MANHOLE COUPLING WITH EPOXY RESIN SAND COATING ON EXTERIOR SURFACE. |
| 13 | SDR-35 PVC PIPE OR C900 PVC DR 14 PIPE. |
| 14 | MANHOLE CONE SHALL BE ECCENTRIC PER IRWD STD. SPEC. SECTION 03461. |

NOTE:
SEE SHEET 2 OF 2 FOR
ADDITIONAL NOTES.

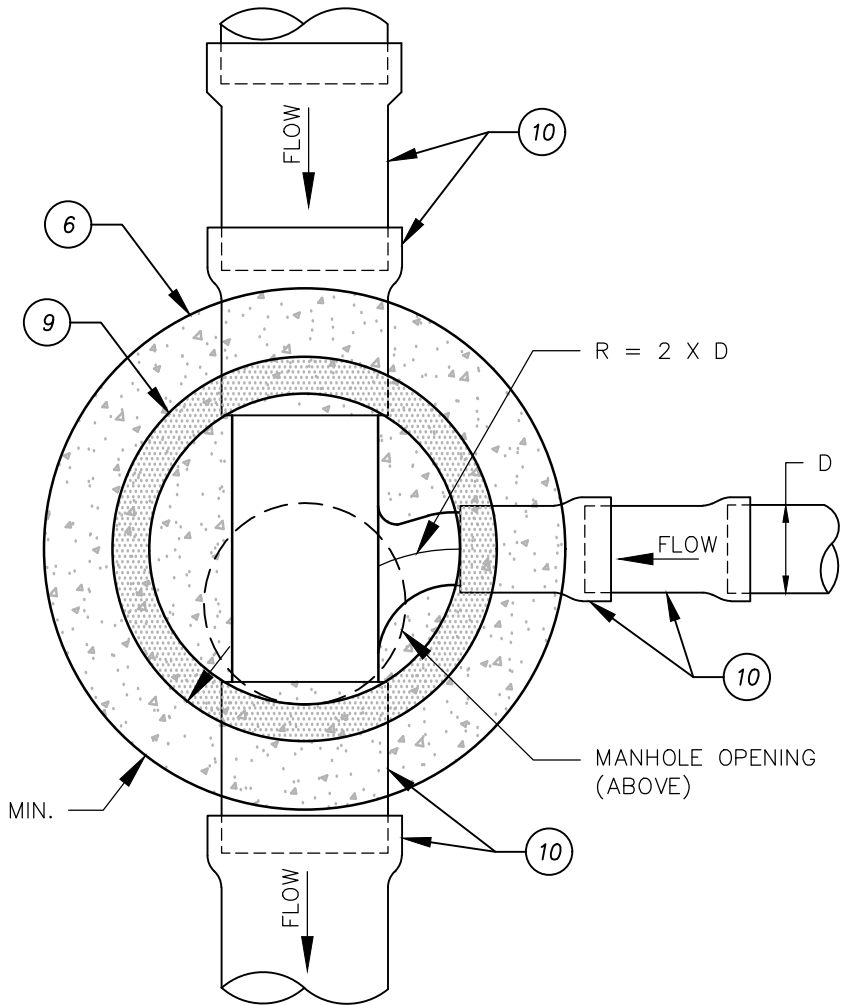

PLAN - MANHOLE BASE

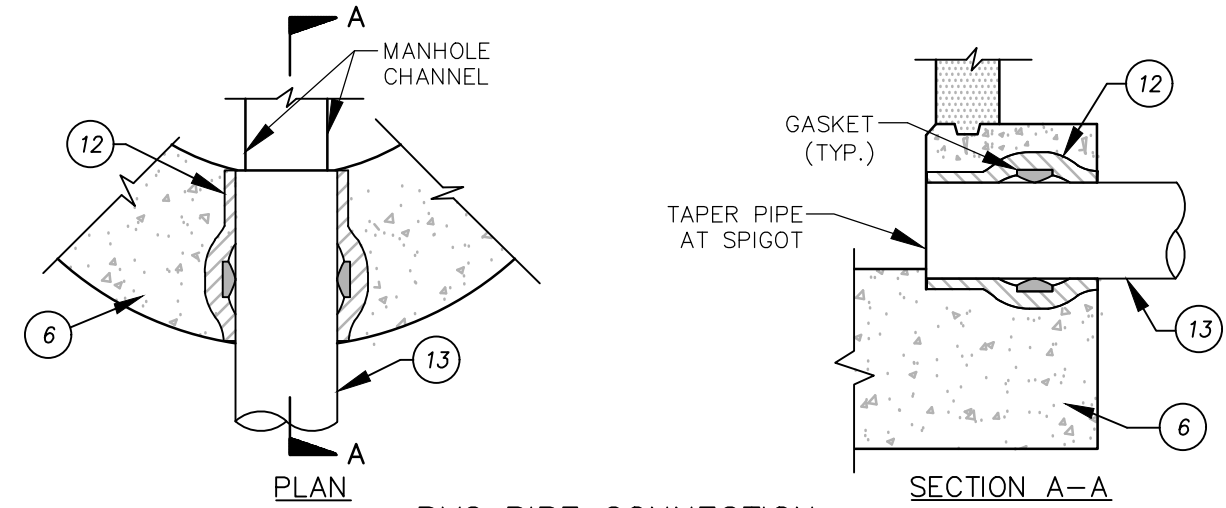

PVC PIPE CONNECTION

MANHOLE

IRVINE RANCH WATER DISTRICT, ENGINEERING DEPARTMENT
 APPROVED BY:
Kevin L. Burton
 KEVIN L. BURTON R.M.E. M28832
 EXECUTIVE DIRECTOR, TECHNICAL SERVICES

FEBRUARY 2025
 REVISION



IRWD
 STD. DWG.
 S-1
 NOT TO SCALE
 SHEET 1 OF 2

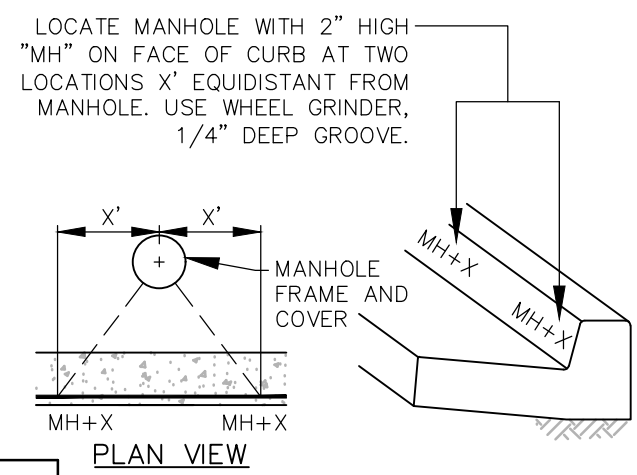
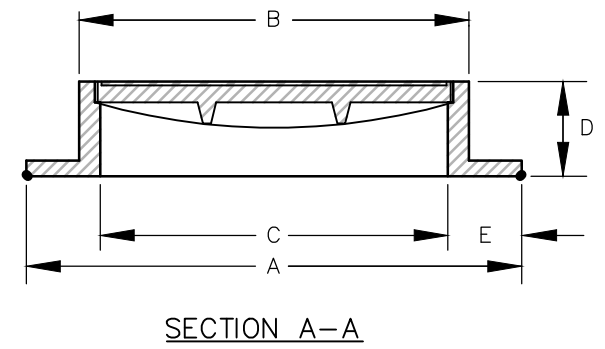
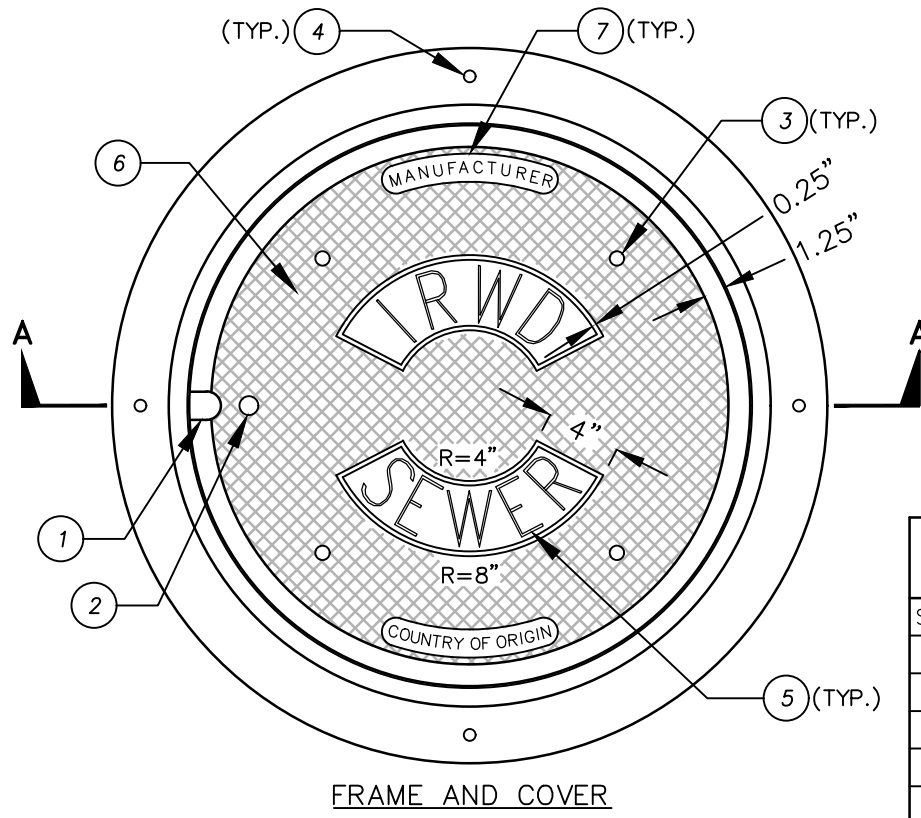

FRAME AND COVER DIMENSIONS			CONCRETE PAD DIMENSIONS	
SIZE (IN)	30	36	COVER SIZE (IN)	SQ. PAD (IN)
A	38	44	30	70
B	33	39	36	75
C	30	36		
D	6	6		
E	4	4		

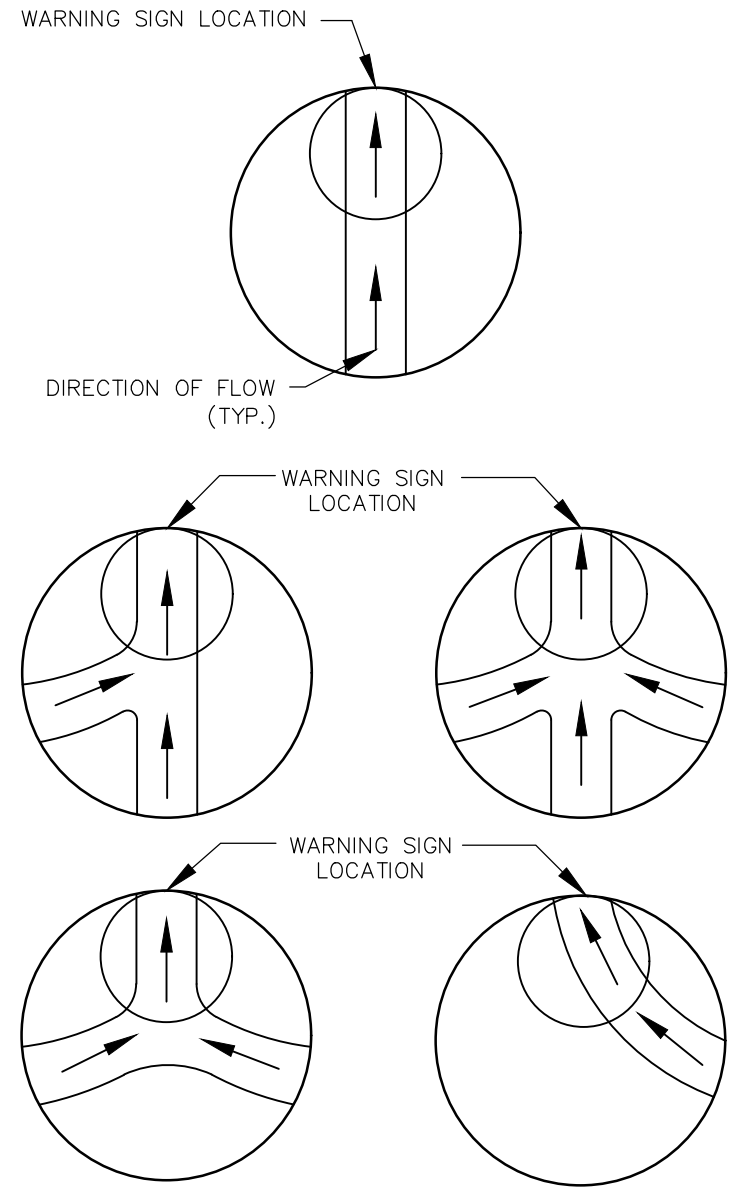
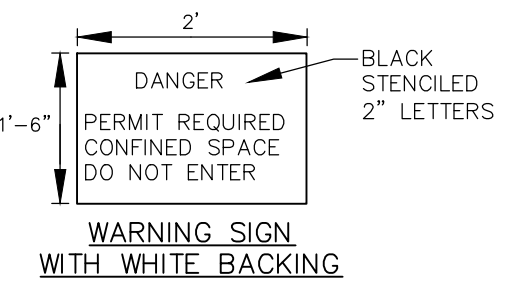

NOTES:

- 48" AND 60" MANHOLES SHALL HAVE 30" COVERS. 72" MANHOLES SHALL HAVE 36" COVERS.
- COAT FRAME AND COVER PER IRWD STD. SPEC. SECTION 09900.
- PLACE TWO HALF MOON SHAPED PLYWOOD COVERS (5/8" THICK MIN.) ON BOTTOM OF MANHOLE AFTER SHAFTS HAVE BEEN SET TO KEEP DEBRIS FROM ENTERING SEWER. REMOVE PLYWOOD PRIOR TO FINAL ACCEPTANCE.
- ALL INLETS AND OUTLETS SHALL BE SUPPORTED WITH CONCRETE BLOCK AND/OR BRICK SUPPORTS, PRIOR TO POURING MANHOLE BASE TO PREVENT PIPE MOVEMENT DURING CONSTRUCTION OF MANHOLE BASE
- ALL PRECAST CONCRETE MANHOLE SHAFTS SHALL BE MANUFACTURED PER IRWD STD. SPEC. SECTION 03461.
- BASE SHALL BE POURED AGAINST UNDISTURBED SOIL. IF SOIL IS DISTURBED, OR IF GROUND WATER EXISTS, CRUSHED ROCK SHALL BE INSTALLED BENEATH BASE PER IRWD STD. SPEC. SECTION 02223.
- CLASS "A" CONCRETE BASE, CAST IN PLACE MONOLITHICALLY.
- PREFORMED COLD-APPLIED READY-TO-USE PLASTIC JOINT SEALING COMPOUND SHALL BE USED FOR ALL MANHOLE JOINTS. REMOVE EXCESS FROM SURFACES INSIDE MANHOLE.
- RETAINING WALLS SHALL BE INSTALLED AROUND MANHOLE WHEN THERE IS AN ADJACENT SLOPE. CONSTRUCT RETAINING WALL PER IRWD STD. DWG. G-4.
- MANHOLES SHALL NOT BE PLACED IN SIDEWALKS OR IN CONCRETE DRIVEWAY APRONS.
- MANHOLES DEEPER THAN 20'-0" TO TOP OF PIPE SHALL BE DESIGNED BY A REGISTERED CIVIL ENGINEER.
- TIE DOWN ALL MANHOLES ON THE NEAREST CURB FACE BY MEANS OF A 4-INCH WHEEL GRINDER, SEE DETAIL ABOVE.
- INSTALL UTILITY MARKER PER IRWD STD. DWG. G-2 FOR MANHOLES WITHIN UNPAVED AREAS.
- PAINTED WARNING SIGN SHALL HAVE WHITE BACKGROUND AND BLACK LETTERS.
- MANHOLE MUST BE CONSTRUCTED AS SHOWN HEREON REGARDLESS OF CONSTRUCTION PHASE. NO INTERIM CONDITIONS WILL BE ACCEPTED.
- STREET REHABILITATION AND/OR ASPHALT OVERLAY PROJECTS SHALL NOT INTERRUPT THE SERVICE FUNCTION OF ANY SEWER MANHOLES AND EMERGENCY ACCESS SHALL BE MAINTAINED AT ALL TIMES. MANHOLES THAT ARE PAVED OVER DURING CONSTRUCTION SHALL BE RAISED TO GRADE NO LATER THAN THREE DAYS AFTER THEY WERE PAVED OVER.
- WHERE THE DISTANCE FROM THE CENTER OF THE MANHOLE TO THE FACE OF THE CURB EXCEEDS 10', THE DISTRICT MAY ACCEPT DRIVABLE ACCESS WITH DEPRESSED CURB.

ITEM	MATERIALS
1	1-1/2" LIFTING SLOT.
2	1" THRU HOLE (ONE PLACE).
3	3/4" THRU HOLE (FOUR PLACES).
4	5/8" DIA. HOLES CORED IN FRAME (FOUR PLACES).
5	CAST 3" LETTERS, 3/8" THICK, RAISED 3/16", OFFSET 0.25" FROM 0.25" THICK RAISED 3/16" RIBBON EDGE.
6	3/16" RAISED DIAMOND TREAD SURFACE PATTERN.
7	MANUFACTURER AND COUNTRY OF ORIGIN STAMP, CAST 1" LETTERS, ORIENTATION AS SHOWN.

MANHOLE			IRWD STD. DWG. S-1 NOT TO SCALE SHEET 2 OF 2
IRVINE RANCH WATER DISTRICT, ENGINEERING DEPARTMENT APPROVED BY: KEVIN L. BURTON R.M.E. M28832 EXECUTIVE DIRECTOR, TECHNICAL SERVICES			

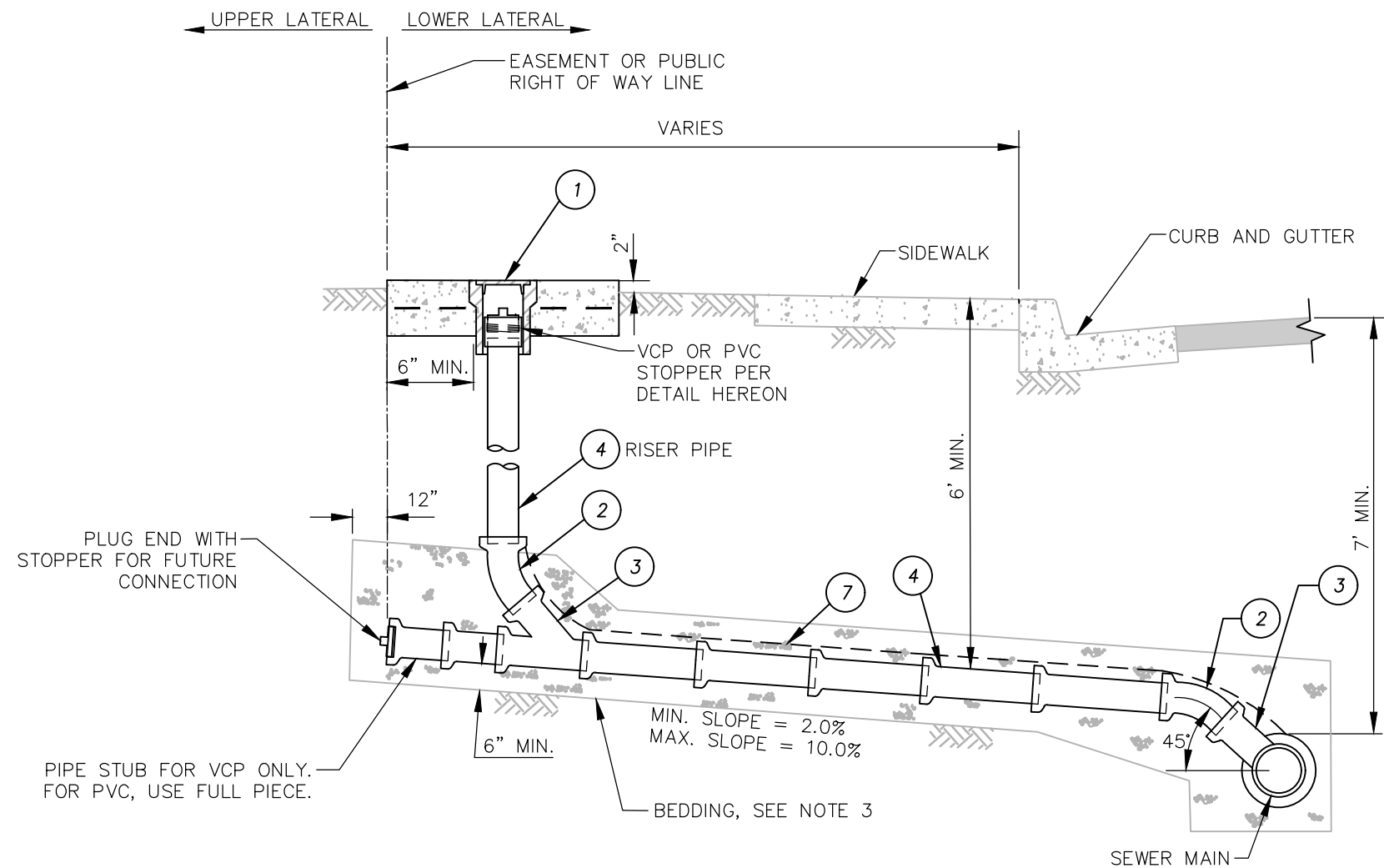

ELEVATION

- | ITEM | MATERIALS |
|------|--|
| 1 | PRECAST BOX, FRAME AND COVER PER IRWD STD. DWG. S-5, COVER SHALL HAVE FOUR 3/4" DIA. HOLES. |
| 2 | 1/8 BEND (OR OTHER FITTING NECESSARY TO ADJUST TO PROPER GRADE). |
| 3 | VCP OR PVC WYE BRANCH FITTING. |
| 4 | VCP OR PVC PIPE. LATERAL MATERIAL SHALL MATCH MAIN MATERIAL. |
| 5 | SOLVENT WELD X F.I.P.T. SCH 40 PVC COUPLING. |
| 6 | PVC SCH. 40 STOPPER M.I.P.T. PLUG WITH MALE SQUARE NUT. |
| 7 | PIPE LOCATOR FOR NON-METALLIC PIPE INSTALLATIONS. IDENTIFICATION TAPE PER IRWD STD. SPEC. SECTION 15151. |
| 8 | BANDIED RUBBER COUPLING. |
| 9 | PLASTIC PLUG. |

NOTES:

- LATERAL SIZE TO BE DETERMINED ON THE BASIS OF TOTAL NUMBER OF FIXTURE UNITS, BUT IN NO CASE SHALL THE LATERAL DIA. BE LESS THAN THE FOLLOWING:
 - 4" FOR SINGLE FAMILY RESIDENTIAL BUILDINGS
 - 6" FOR FAMILY RESIDENTIAL BUILDINGS OR PARKS WITH 6 OR LESS DU'S OR BUILDINGS
 - 8" ALL OTHER BUILDING TYPES INCLUDING BUT NOT LIMITED TO COMMERCIAL, INDUSTRIAL, APARTMENT OR HOTEL BUILDINGS
- LATERAL RISER WHERE REQUIRED SHALL BE INSTALLED IMMEDIATELY ADJACENT TO DEDICATED EASEMENT OR PUBLIC RIGHT OF WAY LINE. OMIT FOR SINGLE FAMILY RESIDENCES.
- PLACE 3/4" CRUSHED ROCK BEDDING PER IRWD STD. SPEC. SECTION 02223.
- PLUG WYE BRANCH WITH ABS STOPPER OR APPROVED "COOKIE".
- CONNECTIONS TO THE RISER PIPE ARE NOT PERMITTED.
- CLEANOUT SHALL NOT BE INSTALLED WITHIN SIDEWALKS, WALKWAYS, CONCRETE SURFACE AREAS, OR ANY PATH OF TRAVEL.

LOCATE LATERAL WITH 2" HIGH "S" ON FACE OF CURB WHERE THE LATERAL CROSSES UNDER THE CURB. USE WHEEL GRINDER, 1/4" DEEP GROOVE.

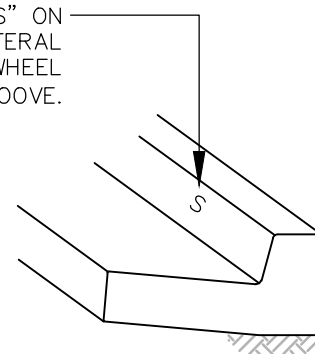

SEWER LATERAL TIE-DOWN

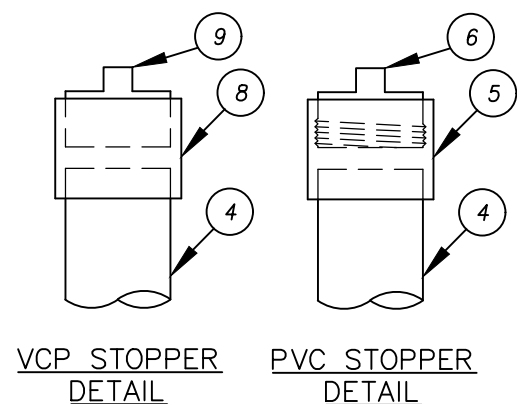

SEWER LATERAL

IRVINE RANCH WATER DISTRICT, ENGINEERING DEPARTMENT

APPROVED BY:

Kevin L. Burton
 KEVIN L. BURTON R.M.E. M28832
 EXECUTIVE DIRECTOR, TECHNICAL SERVICES

FEBRUARY 2025
 REVISION



**IRWD
 STD. DWG.
 S-3**

NOT TO SCALE
 SHEET 1 OF 1

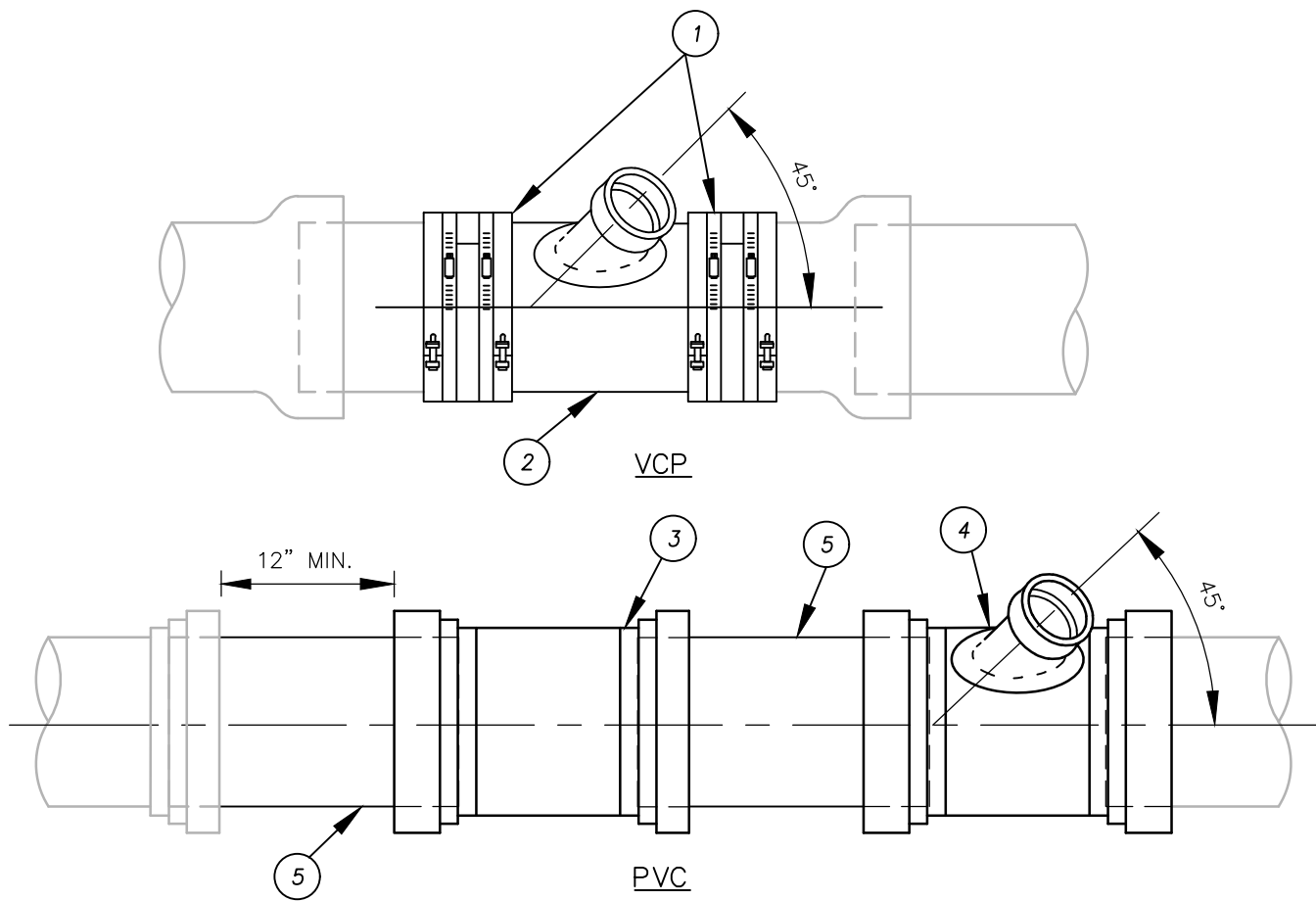

ITEM MATERIALS

- ① — BANDED RUBBER COUPLING WITH OUTSIDE TYPE 316 STAINLESS STEEL SHEAR RING.
- ② — VCP WYE FITTING.
- ③ — GASKETED PVC PIPE COUPLING, REPAIR STYLE.
- ④ — GASKETED PVC WYE FITTING.
- ⑤ — SDR-35 PVC PIPE (PUP), MIN. LENGTH: 12”.

NOTES:

1. WHEN 12” MIN. SPACE BETWEEN EDGE OF COUPLING AND BELL CANNOT BE PROVIDED, CUT-OUT NEAREST BELL JOINT AND INSERT PLAIN-END PIPE.
2. ALL DEBRIS SHALL BE KEPT OUT OF THE SEWER. THE PIPE REACH CUT-INTO SHALL BE CLEANED AND BALLED, IF NECESSARY, AS DIRECTED BY THE DISTRICT REPRESENTATIVE.
3. DAMAGED PIPE SHALL BE REPLACED AS DIRECTED BY THE DISTRICT REPRESENTATIVE.
4. SADDLE-TYPE CONNECTIONS SHALL ONLY BE USED FOR SPECIAL SITUATIONS, AND SHALL NOT BE CONSTRUCTED WITHOUT PRIOR DISTRICT APPROVAL.
5. 8” AND LARGER DIA. LATERALS SHALL BE CONNECTED TO MAIN LINE VIA MANHOLE ONLY, PER IRWD STD. DWG. S-1.

CUT-IN WYE CONNECTION

IRVINE RANCH WATER DISTRICT, ENGINEERING DEPARTMENT

APPROVED BY:

KEVIN L. BURTON R.M.E. M28832
EXECUTIVE DIRECTOR, TECHNICAL SERVICES

FEBRUARY 2025
REVISION



Irvine Ranch
WATER DISTRICT

**IRWD
STD. DWG.
S-4**

NOT TO SCALE
SHEET 1 OF 1

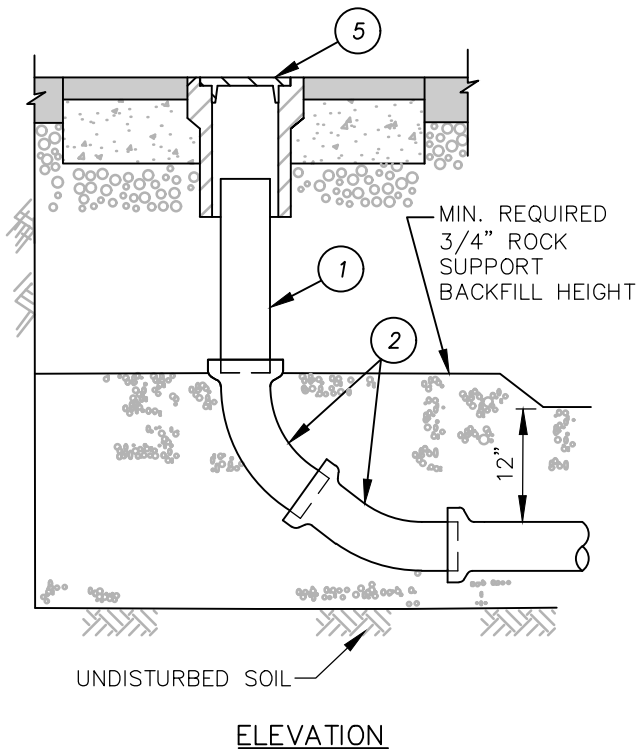
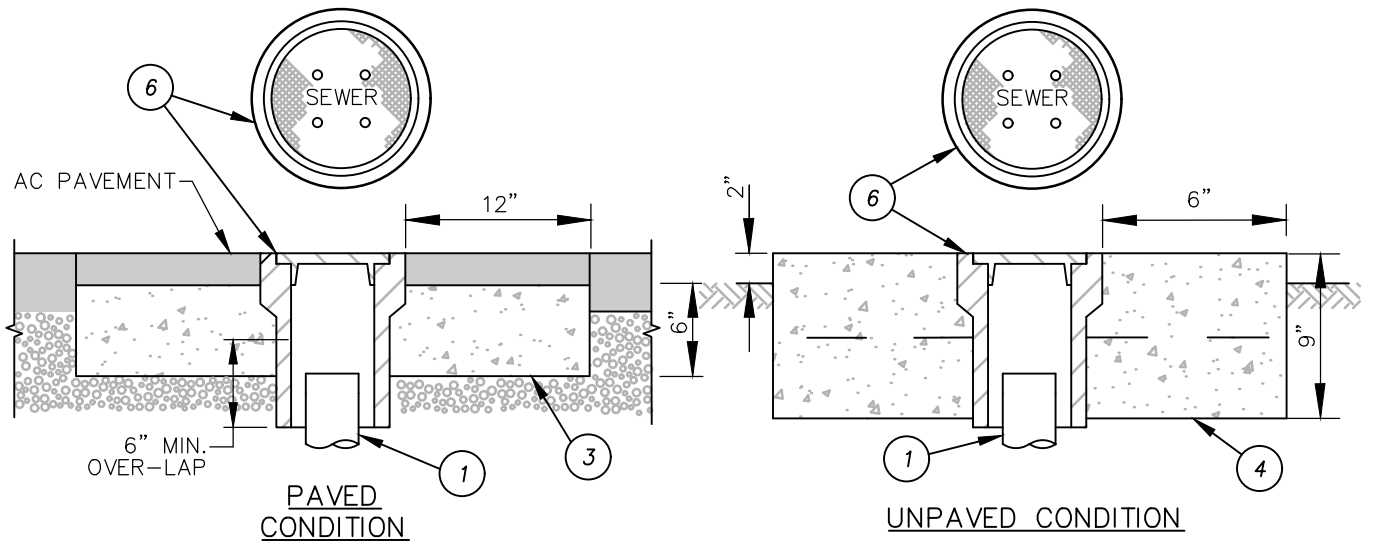

ITEM MATERIAL

- ① — 8" CLEAN-OUT RISER, SEE NOTE 1.
- ② — 8" 45° BEND, LONG-RADIUS SWEEP (VCP ONLY).
- ③ — CLASS "B" CONCRETE COLLAR (ROUND).
- ④ — CLASS "B" CONCRETE COLLAR (SQUARE). WITH W.W.F. 1.6 X 1.6.
- ⑤ — CONSTRUCT FRAME, COVER AND CONCRETE COLLAR PER "PAVED" OR "UNPAVED" CONDITION HEREON.
- ⑥ — PRECAST BOX, FRAME AND COVER WITH MARKING AS SHOWN HEREON. COVER TO HAVE FOUR 3/4" DIA. HOLES. SEE IRWD STD. DWG. W-22 FOR SIMILAR APPLICATION.

NOTES:

1. CLEANOUT RISER PIPE SHALL BE SAME MATERIAL AS SEWER MAIN.
2. SEWER MAINS LARGER THAN 8" SHALL HAVE TERMINAL MANHOLE.
3. USE BAND SEAL RUBBER REDUCER (VCP/PVC) WHEN VCP IS USED.
4. TIE DOWN ALL CLEANOUTS ON THE NEAREST CURB FACE BY MEANS OF A 4-INCH WHEEL GRINDER, SEE DETAIL ON IRWD STD. DWG. S-1, SHEET 2 FOR SIMILAR APPLICATION.
5. CLEANOUT SHALL NOT BE INSTALLED IN SIDEWALK, WALKWAY, CONCRETE SURFACE AREA, OR ANY PATH OF TRAVEL.

TERMINAL CLEANOUT

IRVINE RANCH WATER DISTRICT, ENGINEERING DEPARTMENT

APPROVED BY:

KEVIN L. BURTON R.M.E. M28832
EXECUTIVE DIRECTOR, TECHNICAL SERVICES

FEBRUARY 2025
REVISION



Irvine Ranch
WATER DISTRICT

**IRWD
STD. DWG.
S-5**

NOT TO SCALE
SHEET 1 OF 1

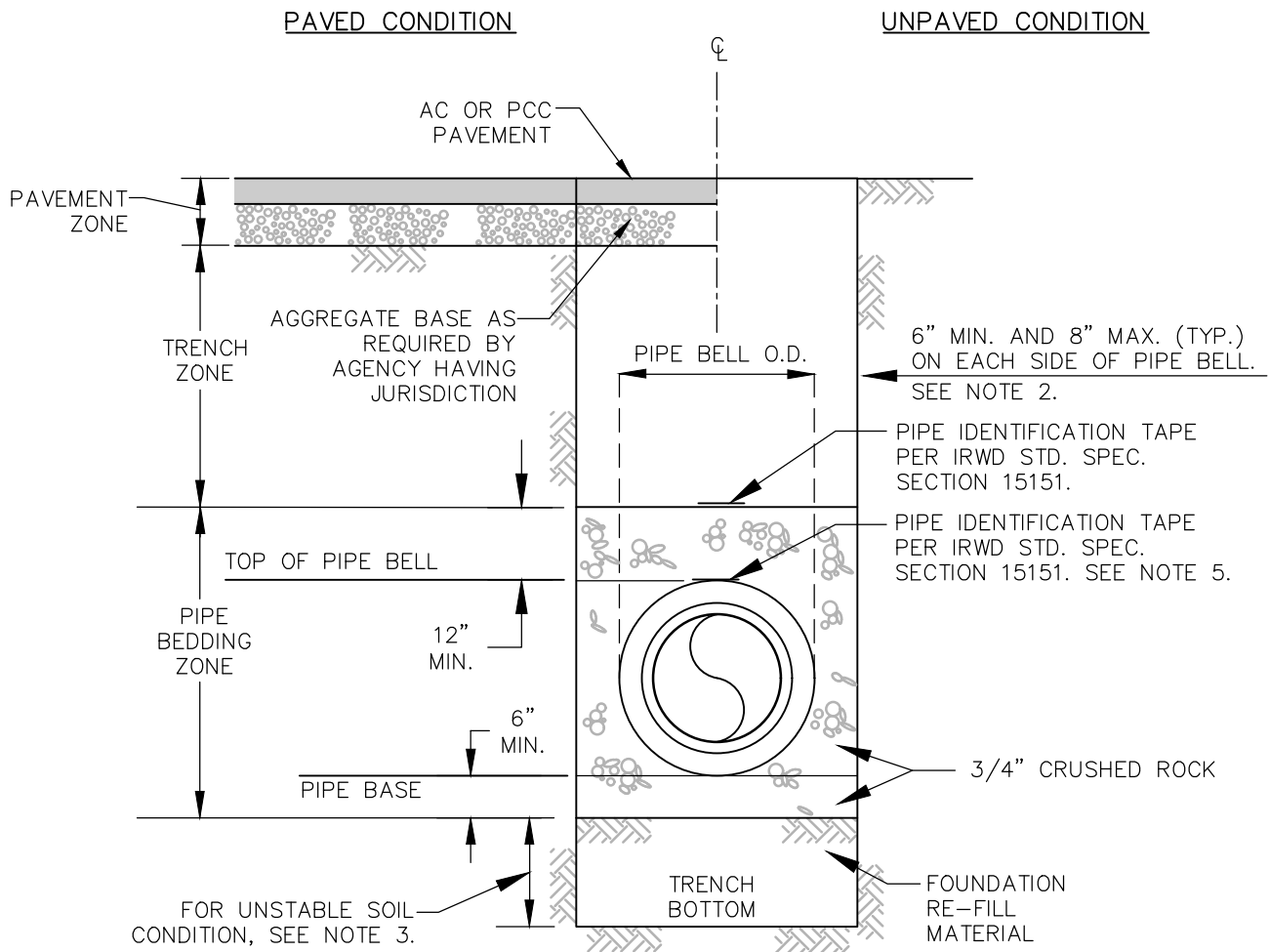

NOTES:

1. ALL WORK SHALL BE IN ACCORDANCE WITH IRWD STD. SPEC. SECTION 02223.
2. WHERE CONTRACTOR FAILS TO MAINTAIN PROPER TRENCH WIDTH LIMITS, SPECIAL BACKFILL (SUCH AS ONE-SACK SLURRY) AND BEDDING SHALL BE REQUIRED AS DETERMINED IN THE FIELD BY THE DISTRICT REPRESENTATIVE.
3. IF UNSTABLE SOIL IS ENCOUNTERED, THE DISTRICT REPRESENTATIVE SHALL DETERMINE OVEREXCAVATION DEPTH AND FOUNDATION RE-FILL MATERIAL PER IRWD STD. SPEC. SECTION 02223.
4. CONTRACTOR SHALL PROVIDE HAND EXCAVATED "BELL HOLE" FOR EACH PIPE JOINT SO THAT THE WEIGHT OF PIPE DOES NOT BEAR ON THE BELL. CONTRACTOR SHALL RE-FILL AND HAND-TAMP EACH "BELL HOLE" PRIOR TO COMPLETING THE PLACEMENT OF PIPE BEDDING.
5. PIPE IDENTIFICATION TAPE SHALL BE INSTALLED PER IRWD STD. SPEC. SECTION 15151. TAPE SHALL BE FASTENED TO THE PIPE WITH 2" WIDE 10 MIL PIPE WRAP TAPE. PIPE WRAP TAPE SHALL BE WRAPPED AROUND THE ENTIRE CIRCUMFERENCE OF THE PIPE.
6. THE MIN. DEPTH OF COVER FROM FINISH GRADE TO THE TOP OF THE SEWER MAIN SHALL BE 7' UNLESS OTHERWISE APPROVED BY THE DISTRICT.

SEWER TRENCH

IRVINE RANCH WATER DISTRICT, ENGINEERING DEPARTMENT

APPROVED BY:

Kevin L. Burton
 KEVIN L. BURTON R.M.E. M28832
 EXECUTIVE DIRECTOR, TECHNICAL SERVICES

FEBRUARY 2025
 REVISION



Irvine Ranch
 WATER DISTRICT

**IRWD
 STD. DWG.
 S-6**

NOT TO SCALE
 SHEET 1 OF 1

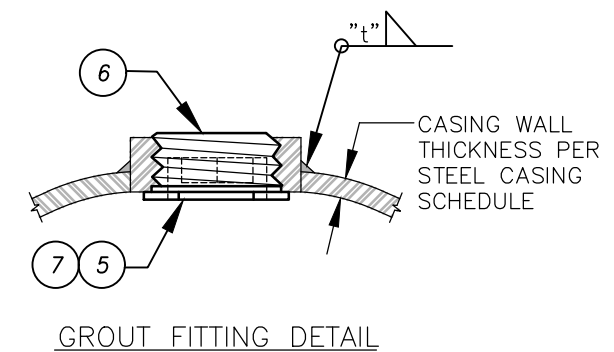
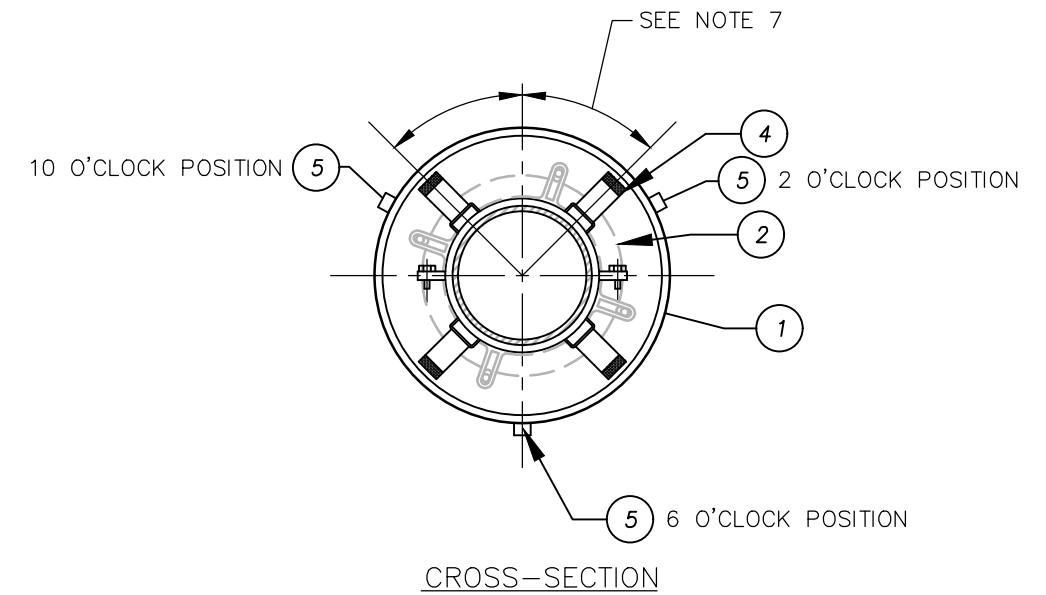
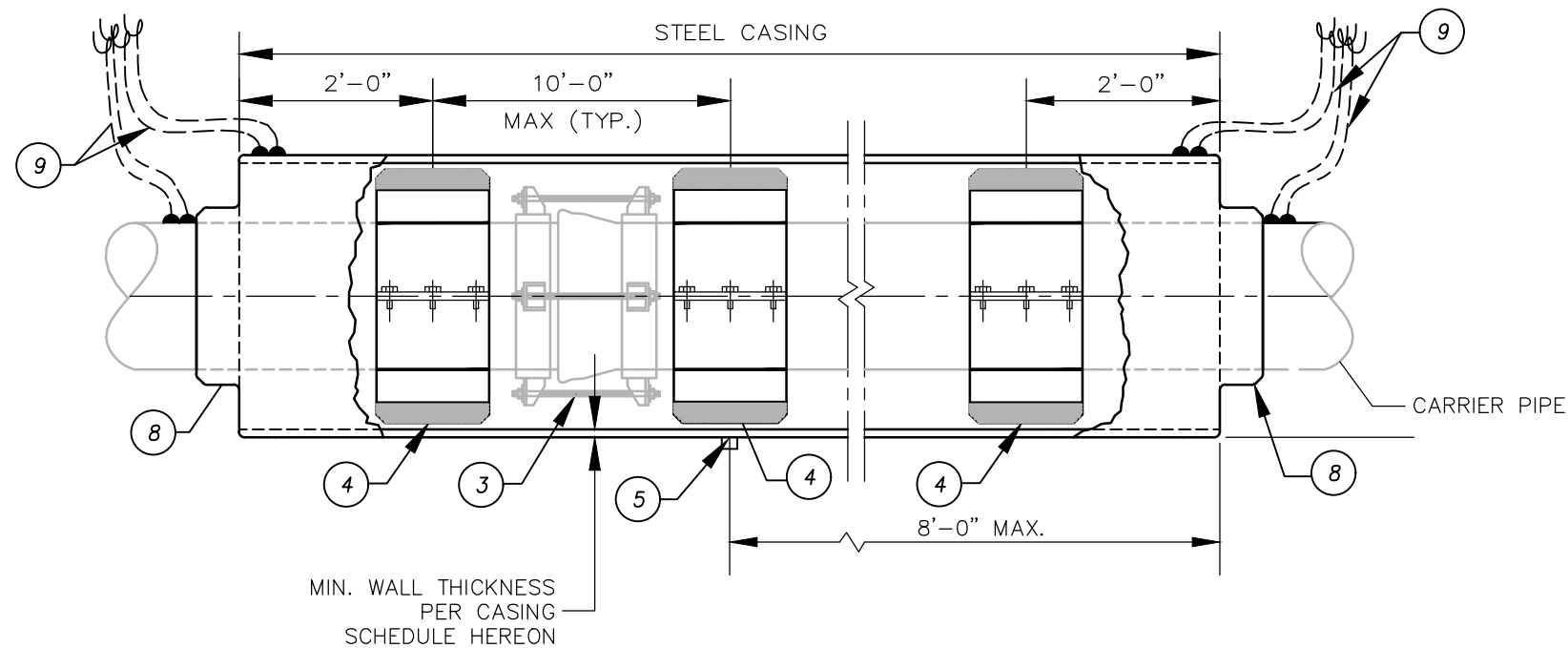

ITEM MATERIALS

- 1 STEEL CASING PER IRWD STD. SPEC. SECTION 02315 AND 02316.
- 2 CARRIER PIPE JOINT BELL, BEYOND.
- 3 CARRIER PIPE WITH ALL JOINTS RESTRAINED.
- 4 STAINLESS STEEL CASING SPACERS WITH UHMW POLYETHYLENE RUNNERS PER IRWD STD. SPEC. SECTION 02315.
- 5 GROUT FITTING @ 8' O.C. PER DETAIL HEREON. FOR ALL CASINGS 30" IN DIA. AND LARGER, INSTALL ONE COUPLING IN 6 O'CLOCK POSITION @ 8' O.C.; STAGGER COUPLINGS BETWEEN 10 O'CLOCK AND 2 O'CLOCK POSITIONS EVERY 4 LINEAR FEET ALONG CASING AXIS.
- 6 3" NPT THREADED STEEL PLUG WITH FLUSH HEAD AND INTERNAL TURN HANDLE.
- 7 2" NPT STANDARD WEIGHT STEEL PIPE HALF COUPLING.
- 8 CASING END SEAL PER IRWD STD. SPEC. SECTION 02315 AND 02316 WITH STAINLESS STEEL WORM-SCREW BAND CLAMPS.
- 9 CASING TEST STATION PER IRWD STD. DWG. CP-3 (OMIT 2 WIRES FOR NON-METALLIC CARRIER PIPE).

NOTES:

1. CASING SHALL BE INSTALLED BY THE BORE, JACK AND/OR TUNNEL METHOD, OR OPEN TRENCH. SEE IRWD STD. SPEC. SECTIONS 02315 AND 02316. BEDDING MATERIAL FOR OPEN TRENCH CASING INSTALLATION SHALL CONSIST OF 6" OF 3/4" CRUSHED ROCK.
2. SIZE AND THICKNESS OF CASING SHALL BE AS SHOWN IN SCHEDULE. FOR LONG BORES OR SPECIAL SITUATIONS GREATER WALL THICKNESS THAN SHOWN IN SCHEDULE MAY BE REQUIRED.
3. ALL STEEL CASING PIPE FIELD JOINTS SHALL BE WELDED FULL-CIRCUMFERENCE.
4. CARRIER PIPE SHALL BE PRESSURE TESTED PRIOR TO SEALING ENDS OF CASING.
5. EACH END OF CASING SHALL BE SEALED WITH APPROVED RUBBER CASING END SEALS.
6. BACKFILL FOR CASING IN OPEN CUT SHALL BE PER IRWD STD. DWG. S-6.
7. NUMBER AND PLACEMENT OF SPACERS ON CARRIER PIPE PER MANUFACTURER'S SPECIFICATION.
8. CATHODIC PROTECTION REQUIRED FOR STEEL CASING 40 FEET IN LENGTH AND LONGER ONLY.
9. ALL CARRIER PIPE JOINTS INSIDE THE STEEL CASING AND A MIN. 5' OUTSIDE STEEL CASING SHALL BE RESTRAINED.
10. REFER TO TABLE IN IRWD STD. SPEC SECTION 02315 AND 02316 FOR ANNULAR SPACE FILL REQUIREMENTS.

STEEL CASING SCHEDULE		
NOMINAL CARRIER PIPE SIZE	MINIMUM CASING SIZE (NOMINAL)	MINIMUM WALL THICKNESS
4"	12"	1/4"
6"	16"	5/16"
8"	18"	5/16"
10"	20"	5/16"
12"	24"	3/8"
14"	27"	3/8"
16"	30"	3/8"
18"	30"	1/2"
20"	36"	1/2"
24"	42"	1/2"

STEEL CASING FOR SEWER PIPE

IRVINE RANCH WATER DISTRICT, ENGINEERING DEPARTMENT
 APPROVED BY:

 KEVIN L. BURTON R.M.E. M28832
 EXECUTIVE DIRECTOR, TECHNICAL SERVICES

FEBRUARY 2025
 REVISION



IRWD
 STD. DWG.
 S-7
 NOT TO SCALE
 SHEET 1 OF 1

TABLE OF CONTENTS

Cathodic Protection Standard Drawings

NUMBER	DESCRIPTION	DATE
CP-1	Two Wire Test Station	Feb 2025
CP-2	<Not Used>	
CP-3	Casing Test Station	Feb 2025
CP-4	Insulator Test Station	Feb 2025
CP-5	Cathodic Protection Rectifier and Shunt Panel	Feb 2025
CP-6	Test Box, Wiring, and Identification Tags	Feb 2025
CP-7	Test Box Locations	Feb 2025
CP-8	Alumino-Thermic (CAD) Welding	Feb 2025
CP-9	Bonding for Pipe Joints and Fittings	Feb 2025
CP-10	Insulating Joints	Feb 2025

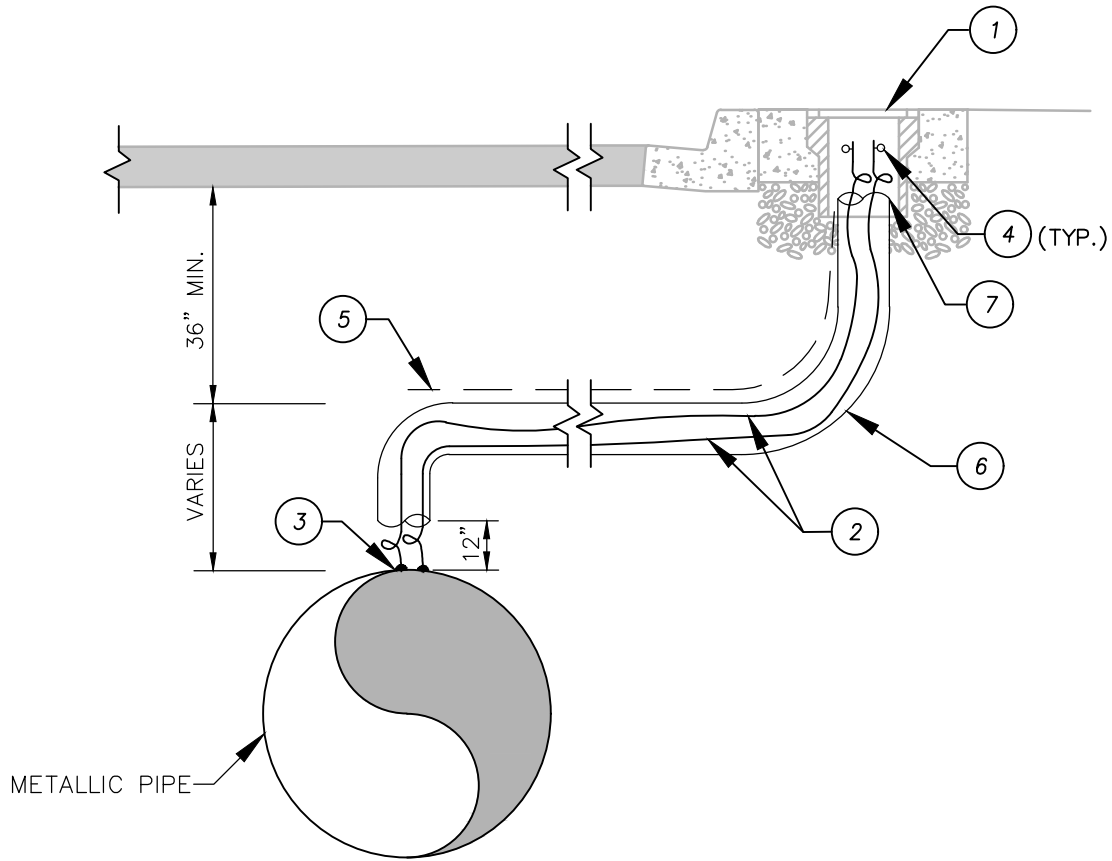

ITEM MATERIALS

- ① — TEST BOX AND CONCRETE PAD PER IRWD STD. DWG. CP-6.
- ② — NO. 8 STRANDED COPPER WIRE WITH BLACK INSULATION PER IRWD STD. SPEC. SECTION 16640. COIL BOTH ENDS PER NOTE 1.
- ③ — ALUMINO-THERMIC WELD PER IRWD STD. SPEC. SECTION 16640 AND IRWD STD. DWG. CP-8 AND CP-9 (FOR METALLIC PIPE ONLY).
- ④ — IDENTIFICATION TAGS PER IRWD STD. DWG. CP-6.
- ⑤ — IDENTIFICATION TAPE PER IRWD STD. SPEC. SECTION 15151.
- ⑥ — 2" SCH 40 PVC CONDUIT WITH LONG SWEEP ELBOWS FROM PIPE TO TEST BOX.
- ⑦ — CAP CONDUIT END WITH DUCT SEAL, GARDNER BENDER DS-110N, OR EQUAL.

NOTES:

- 1. PROVIDE 36" OF COILED SLACK IN EACH WIRE AT EACH END (I.E. AT PIPE AND AT BOX). PUT THE SLACK AT THE BOX END INSIDE THE BOX.
- 2. FOR TEST STATIONS ON PIPES IN STREETS, SEE IRWD STD. DWG. CP-7.

TWO WIRE TEST STATION

IRVINE RANCH WATER DISTRICT, ENGINEERING DEPARTMENT

APPROVED BY:

KEVIN L. BURTON R.M.E. M28832
EXECUTIVE DIRECTOR, TECHNICAL SERVICES

FEBRUARY 2025
REVISION



Irvine Ranch
WATER DISTRICT

**IRWD
STD. DWG.
CP-1**

NOT TO SCALE
SHEET 1 OF 1

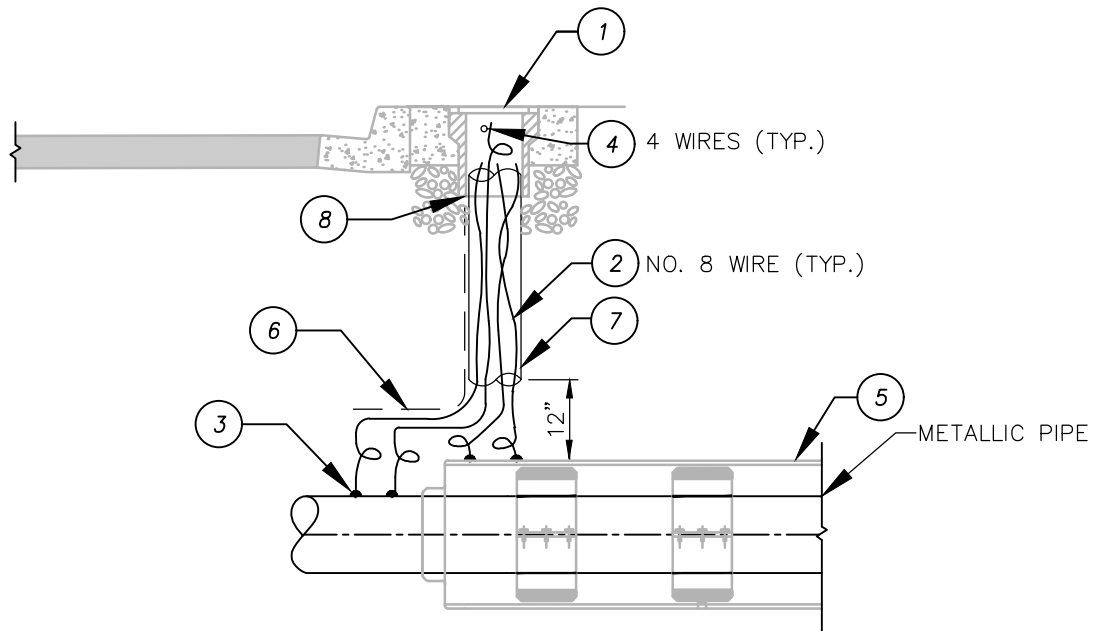

ITEM MATERIALS

- ① — TEST BOX AND CONCRETE PAD PER IRWD STD. DWG. CP-6.
- ② — NO. 8 STRANDED COPPER WIRE WITH BLACK INSULATION PER IRWD STD. SPEC. SECTION 16640. COIL BOTH ENDS PER NOTE 5. CONNECT WIRES WITHIN 5 FEET OF END OF CASING.
- ③ — ALUMINO-THERMIC WELD PER IRWD STD. SPEC. SECTION 16640 AND IRWD STD. DWG. CP-8 AND CP-9 (FOR METALLIC PIPE ONLY).
- ④ — IDENTIFICATION TAGS PER IRWD STD. DWG. CP-6.
- ⑤ — STEEL CASING PER IRWD STD. DWG. W-21 AND S-7.
- ⑥ — IDENTIFICATION TAPE PER IRWD STD. SPEC. SECTION 15151.
- ⑦ — 2" SCH 40 PVC CONDUIT WITH LONG SWEEP ELBOWS FROM PIPE TO TEST BOX.
- ⑧ — CAP CONDUIT END WITH DUCT SEAL, GARDNER BENDER DS-110N, OR EQUAL.

NOTES:

1. FOR TEST STATIONS INSTALLED CROSS COUNTRY OR IN UNPAVED AREAS, A UTILITY MARKER SHALL BE INSTALLED ADJACENT TO TEST STATION AND APPURTENANCES PER IRWD STD. DWG. G-2.
2. FOR TEST BOX LOCATIONS, SEE IRWD STD. DWG. CP-7.
3. THE TEST STATION SHALL EXTEND PERPENDICULAR TO THE CENTERLINE OF THE STREET FROM THE WATER MAIN TO THE TEST STATION BOX.
4. THE TEST BOX SHALL BE SET BEHIND SIDEWALK WHERE SIDEWALK IS ADJACENT TO CURB OR IN PARKWAY BETWEEN CURB AND SIDEWALK.
5. PROVIDE 36" OF COILED SLACK IN EACH WIRE AT EACH END (I.E. AT PIPE AND AT BOX). PUT THE SLACK AT THE BOX END INSIDE THE BOX.

CASING TEST STATION

IRVINE RANCH WATER DISTRICT, ENGINEERING DEPARTMENT

APPROVED BY:

KEVIN L. BURTON R.M.E. M28832
EXECUTIVE DIRECTOR, TECHNICAL SERVICES

FEBRUARY 2025
REVISION



Irvine Ranch
WATER DISTRICT

**IRWD
STD. DWG.
CP-3**

NOT TO SCALE
SHEET 1 OF 1

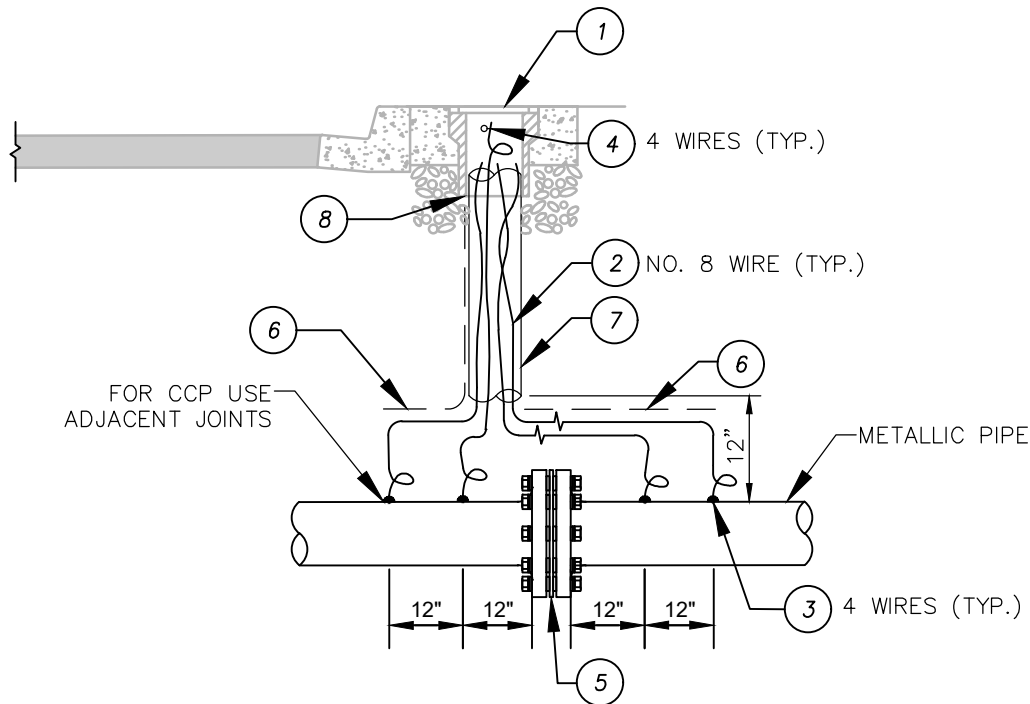

ITEM MATERIALS

- ① — TEST BOX AND CONCRETE PAD PER IRWD STD. DWG. CP-6.
- ② — NO. 8 STRANDED COPPER WIRE WITH BLACK INSULATION PER IRWD STD. SPEC. SECTION 16640. COIL BOTH ENDS PER NOTE 5.
- ③ — ALUMINO-THERMIC WELD PER IRWD STD. SPEC. SECTION 16640 AND IRWD STD. DWG. CP-8 AND CP-9 (FOR METALLIC PIPE ONLY).
- ④ — IDENTIFICATION TAGS PER IRWD STD. DWG. CP-6.
- ⑤ — INSULATING TEST KIT PER IRWD STD. DWG. CP-10.
- ⑥ — IDENTIFICATION TAPE PER IRWD STD. SPEC. SECTION 15151.
- ⑦ — 2" SCH 40 PVC CONDUIT WITH LONG SWEEP ELBOWS FROM PIPE TO TEST BOX.
- ⑧ — CAP CONDUIT END WITH DUCT SEAL, GARDNER BENDER DS-110N, OR EQUAL.

NOTES:

1. FOR TEST STATIONS INSTALLED CROSS COUNTRY OR IN UNPAVED AREAS, A UTILITY MARKER SHALL BE INSTALLED ADJACENT TO TEST STATION AND APPURTENANCES PER IRWD STD. DWG. G-2.
2. FOR TEST BOX LOCATIONS, SEE IRWD STD. DWG. CP-7.
3. THE TEST STATION SHALL EXTEND PERPENDICULAR TO THE CENTERLINE OF THE STREET FROM THE WATER MAIN TO THE TEST STATION BOX.
4. THE TEST BOX SHALL BE SET BEHIND SIDEWALK WHERE SIDEWALK IS ADJACENT TO CURB OR IN PARKWAY BETWEEN CURB AND SIDEWALK.
5. PROVIDE 36" OF COILED SLACK IN EACH WIRE AT EACH END (I.E. AT PIPE AND AT BOX). PUT THE SLACK AT THE BOX END INSIDE THE BOX.

INSULATOR TEST STATION

IRVINE RANCH WATER DISTRICT, ENGINEERING DEPARTMENT

APPROVED BY:

KEVIN L. BURTON R.M.E. M28832
EXECUTIVE DIRECTOR, TECHNICAL SERVICES

FEBRUARY 2025
REVISION



Irvine Ranch
WATER DISTRICT

**IRWD
STD. DWG.
CP-4**

NOT TO SCALE
SHEET 1 OF 1

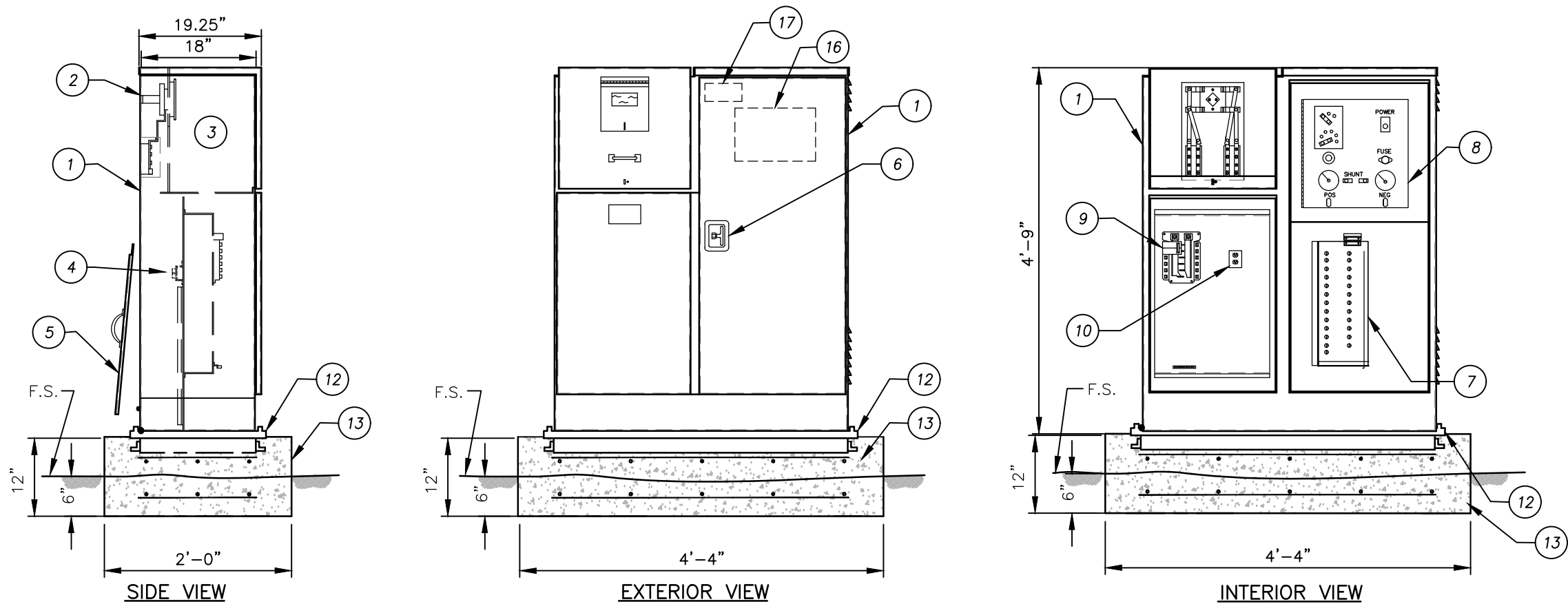

ITEM MATERIALS

- 1 — COMBINATION ELECTRIC SERVICE AND RECTIFIER CABINET. MYERS POWER PEDESTAL PRODUCT NO. MEUG46IX-M100-316.
- 2 — SCE METER SOCKET.
- 3 — SCE METER SECTION.
- 4 — UTILITY LANDING.
- 5 — REMOVABLE UTILITY ACCESS COVER WITH PADLOCK.
- 6 — T-HANDLE WITH PADLOCK HASP.
- 7 — SHUNT PANEL. SEE SHEET 2 OF 2.
- 8 — RECTIFIER. SEE SHEET 2 OF 2. MOUNT IN CABINET WITH "SLIDE-OUT" RACK.
- 9 — 12 CIRCUIT LOAD CENTER.
- 10 — GFI RECEPTACLE, 20 AMP.
- 11 — COPPER CLAD GROUND ROD WITH NO. 6 AWG BARE SOLID COPPER CONDUCTOR. CADWELD TO GROUND ROD AND PEDESTAL.
- 12 — MYERS PAD MOUNTING BASE PRODUCT NO. MEUG46-BASE.
- 13 — CONCRETE PAD WITH NO. 4 BARS @ 12" O.C. BOTH WAYS TOP AND BOTTOM.
- 14 — 2" SCH 40 CONDUIT, EXTEND 2" ABOVE CONCRETE PAD.
- 15 — 3" SCH 40 CONDUIT, EXTEND 2" ABOVE CONCRETE PAD.
- 16 — METAL POCKET HOLDER ATTACHED TO INSIDE OF CABINET DOOR.
- 17 — SCE ADDRESS WITH VINYL ADHESIVE 1" DIE CUT VINYL LETTERS ON EXTERIOR OF CABINET DOOR.

NOTE:

1. CONDUIT PENETRATIONS THROUGH SLAB AND IN AND OUT OF CABINETS SHALL BE PVC LINED AND COATED OCAL PER IRWD STD. SPEC. SECTION 16110.

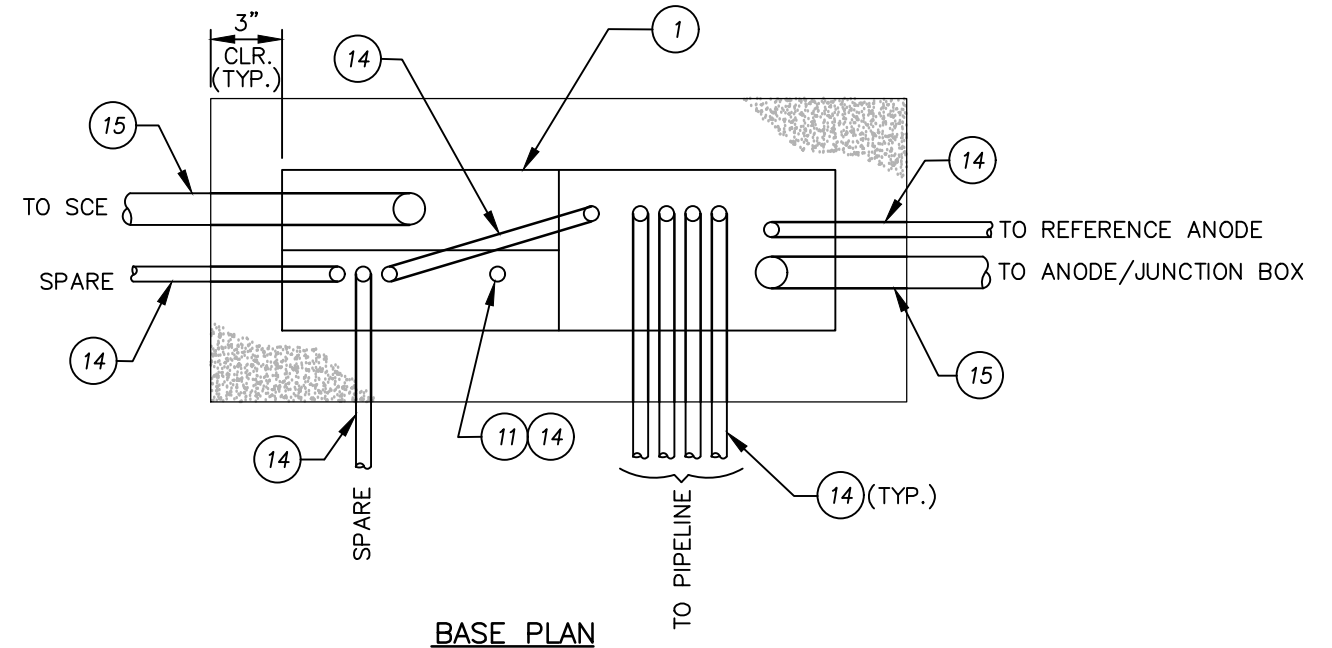

CATHODIC PROTECTION RECTIFIER AND SHUNT PANEL

IRVINE RANCH WATER DISTRICT, ENGINEERING DEPARTMENT

APPROVED BY:

Kevin L. Burton

KEVIN L. BURTON R.M.E. M28832
EXECUTIVE DIRECTOR, TECHNICAL SERVICES

FEBRUARY 2025

REVISION



Irvine Ranch
WATER DISTRICT

IRWD
STD. DWG.
CP-5

NOT TO SCALE
SHEET 1 OF 2

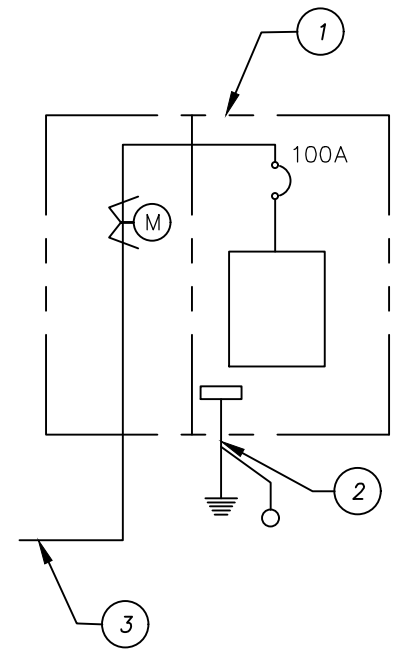

SINGLE LINE DIAGRAM

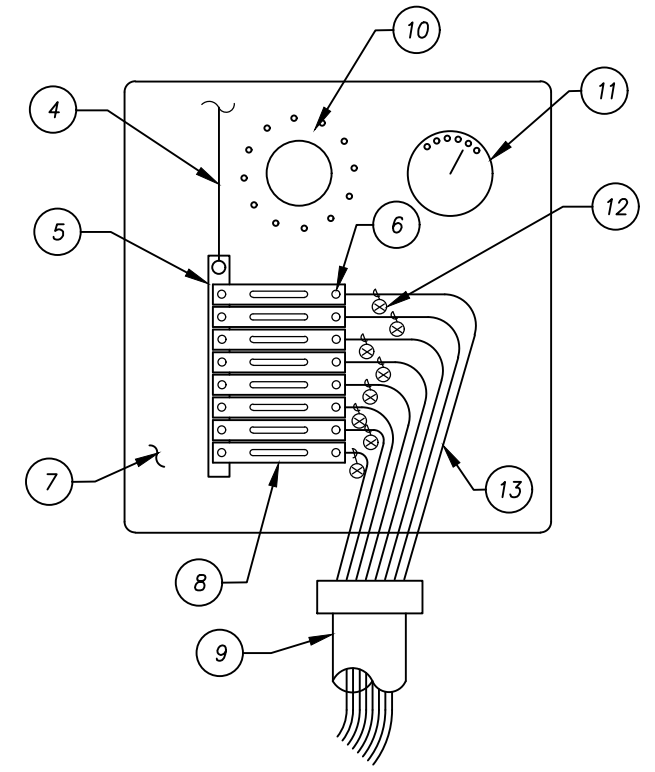

TO ANODE/JUNCTION BOX
ANODE SHUNT PANEL

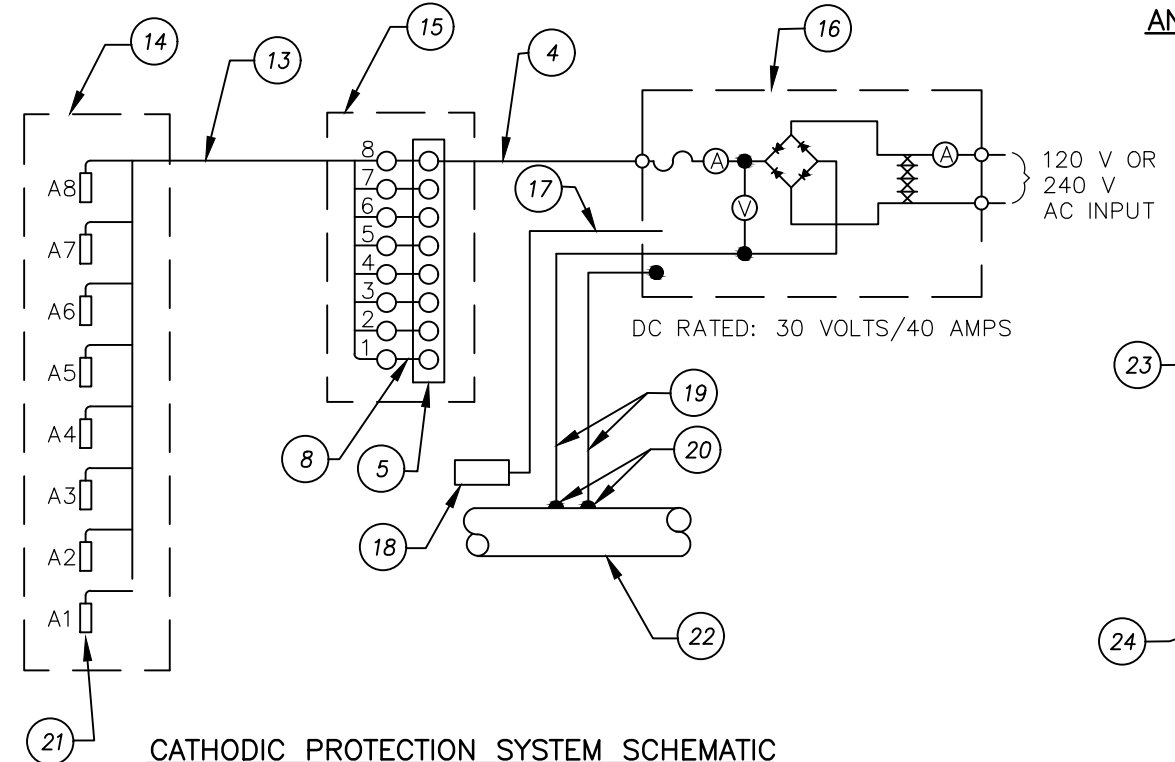

CATHODIC PROTECTION SYSTEM SCHEMATIC

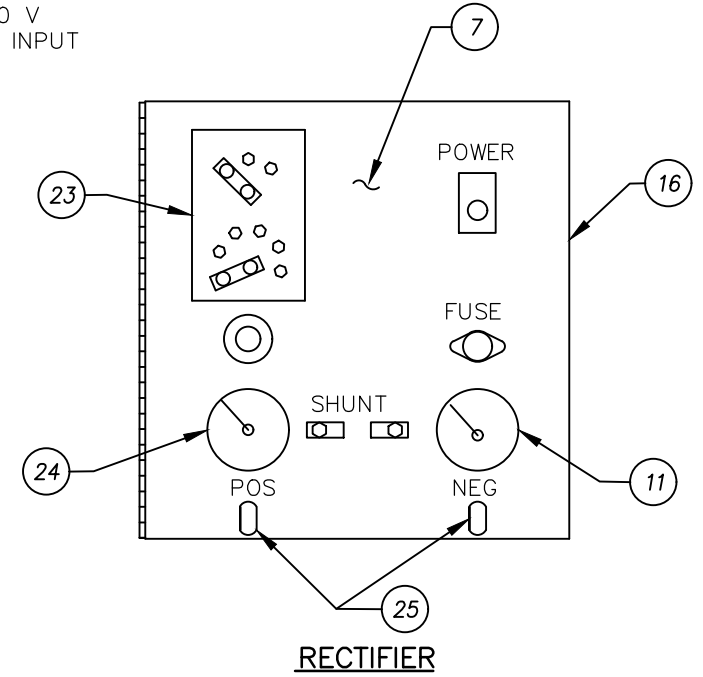

RECTIFIER

- | ITEM | MATERIALS |
|------|--|
| 1 | COMBINATION ELECTRIC SERVICE AND RECTIFIER CABINET. MYERS POWER PEDESTAL PRODUCT NO. MEUG46IX-M100-316. |
| 2 | COPPER CLAD GROUND ROD WITH NO. 6 AWG BARE SOLID COPPER CONDUCTOR. CADWELD TO GROUND ROD AND PEDESTAL. |
| 3 | 3" CONDUIT TO ELECTRIC UTILITY MANHOLE. |
| 4 | ANODE HEADER WIRE NO. 4 AWG STRANDED COPPER WIRE WITH HMWPE INSULATION TO RECTIFIER. |
| 5 | COPPER BUS BAR (1' X 1/8"). |
| 6 | SCREW TERMINALS. ILSCO SLU-70 COPPER MECHANICAL LUG, OR EQUAL. |
| 7 | BAKELITE PANEL MATERIAL, ENGRAVED. |
| 8 | 0.01 OHM SHUNT (TYP. OF 8) UNLESS SHOWN OTHERWISE ON THE DRAWINGS |
| 9 | 3" SCH 40 PVC CONDUIT TO ANODE BED 3"Ø CASING. INSTALL WEATHERPROOF SEALING MASTIC INSIDE CONDUIT TO SEAL OUT GASSES FROM ANODE BED. |
| 10 | INDIVIDUAL SHUNT OUTPUT SELECTOR SWITCH. |
| 11 | PANEL-MOUNT DC AMMETER. |
| 12 | PVC IDENTIFICATION TAG WITH ANODE NUMBER (TYP. OF 8) UNLESS SHOWN OTHERWISE ON THE DRAWINGS. |
| 13 | ANODE LEAD WIRES (TYP. OF 8) PER IRWD STD. SPEC. SECTION 16640 UNLESS SHOWN OTHERWISE ON THE DRAWINGS. |
| 14 | DEEP ANODE SYSTEM PER IRWD STD. SPEC. SECTION 16640. |
| 15 | ANODE SHUNT PANEL WITH SHUNT SELECT SWITCH AND AMMETER. |
| 16 | UNIVERSAL AIR COOLED STANDARD LINE RECTIFIER. AIR-COOLED WITH MANUAL TAP ADJUSTMENT. MOUNT IN CABINET WITH SLIDE-OUT RACK. |
| 17 | ANODE HEADER WIRE PER IRWD STD. SPEC. SECTION 16640. |
| 18 | REFERENCE ELECTRODE PER IRWD STD. SPEC. SECTION 16640. |
| 19 | PIPE LEAD WIRE PER IRWD STD. SPEC. SECTION 16640 |
| 20 | ALUMINO-THERMIC WELD. SEE IRWD STD. DWG. CP-8. |
| 21 | ANODES (TYP. OF 8) UNLESS SHOWN OTHERWISE ON THE DRAWINGS. |
| 22 | PIPELINE BEING PROTECTED. |
| 23 | COARSE AND FINE STEP VOLTAGE CONTROL TAPS. |
| 24 | PANEL-MOUNT DC VOLT METER. |
| 25 | DC OUTPUT TERMINALS WITH SOLDERLESS LUG. |

NOTES:

- SERIES CONNECTED RATING OF BREAKERS MAY BE USED. ALL BREAKERS MUST BE OF SAME MANUFACTURER AND U.L. LISTED SERIES CONNECTED SHORT CIRCUIT RATING FOR THAT VOLTAGE.
- FIELD MARKED ON ALL EQUIPMENT SHALL READ: "CAUTION SERIES RATED SYSTEM 42,000A AVAILABLE IDENTIFIED REPLACEMENT COMPONENT REQUIRED".

CATHODIC PROTECTION RECTIFIER AND SHUNT PANEL		
IRVINE RANCH WATER DISTRICT, ENGINEERING DEPARTMENT		
APPROVED BY: <i>Kevin L. Burton</i>		
KEVIN L. BURTON R.M.E. M28832 EXECUTIVE DIRECTOR, TECHNICAL SERVICES		FEBRUARY 2025 REVISION
Irvine Ranch WATER DISTRICT		IRWD STD. DWG. CP-5 NOT TO SCALE SHEET 2 OF 2

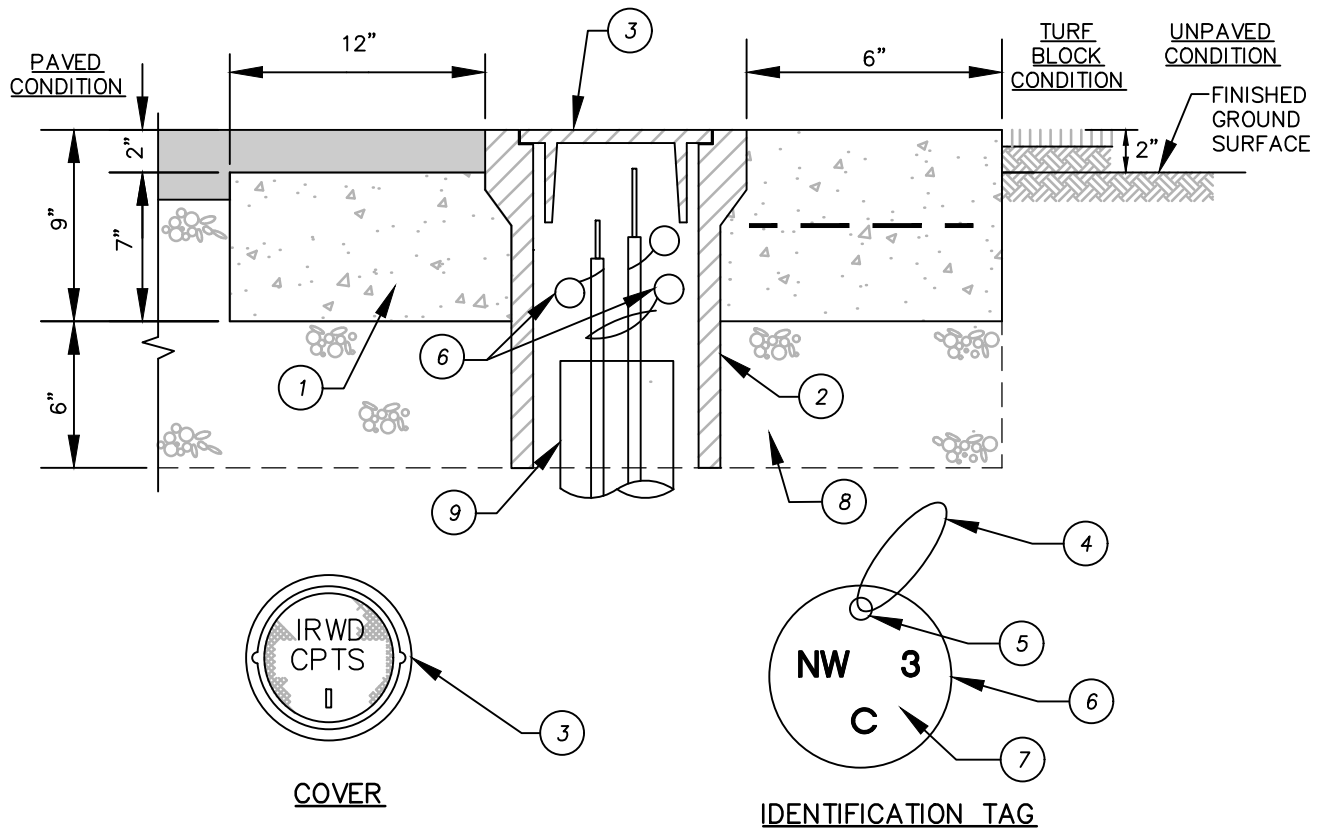

- | ITEM | MATERIALS |
|------|---|
| 1 | CLASS "B" CONCRETE COLLAR. REINFORCE WITH W.W.F. 1.6 X 1.6 IN UNPAVED AND TURF BLOCK CONDITIONS. |
| 2 | TEST BOX AND FRAME PER IRWD STD. SPEC. SECTION 16640. |
| 3 | TEST BOX COVER PER DETAIL HEREON. CAST IRON LID PER IRWD STD. SPEC. SECTION 16640. |
| 4 | NYLON WIRE. |
| 5 | 3/16" DIA. HOLE. |
| 6 | 2" DIA. PVC IDENTIFICATION TAG PER IRWD STD. SPEC. SECTION 16640 AND DETAIL HEREON. SEE SHEET 2 FOR TEST BOX IDENTIFICATION TAG AND WIRE IDENTIFICATION TAG LABELING STANDARDS. BLANK PVC IDENTIFICATION TAG PROVIDED BY IRWD FOR CONTRACTOR'S USE. |
| 7 | 1/4" HIGH LETTERS AND NUMBERS. |
| 8 | 3/4" CRUSHED ROCK BEDDING. |
| 9 | 2" SCH. 40 PVC CONDUIT. |

NOTES:

1. INSTALLATION TYPICAL FOR TWO WIRE, INSULATING JOINT, AND CASING TEST STATIONS. SEE SHEET 2 FOR LABELING STANDARDS.
2. PROVIDE 36" OF COILED SLACK IN EACH WIRE AT EACH END (I.E. AT PIPE AND AT BOX). PUT THE SLACK AT THE BOX END INSIDE THE BOX.
3. STRIP INSULATION FROM END OF EACH TEST LEAD, MIN. 1/4", MAX. 1/2". INSTALL WIRE NUTS AND ANTI-ARC COMPOUND TO PROTECT BARE WIRE ENDS.

TEST BOX, WIRING, AND IDENTIFICATION TAGS

IRVINE RANCH WATER DISTRICT, ENGINEERING DEPARTMENT

APPROVED BY:

Kevin L. Burton
 KEVIN L. BURTON R.M.E. M28832
 EXECUTIVE DIRECTOR, TECHNICAL SERVICES

FEBRUARY 2025
 REVISION



IRWD
 STD. DWG.
 CP-6

NOT TO SCALE
 SHEET 1 OF 2

WIRE NUMBER

X = SEQUENTIAL, 1 DIGIT NUMBER ASSIGNED TO EACH TEST STATION WIRE; UNIQUE TO EACH TEST WIRE. LOWEST NUMBERS (1 AND 2) ARE TO BE CLOSEST TO THE JOINT OR TEST BOX SITE.

FACILITY IDENTIFIER

P = PIPELINE
C = CASING
A = ANODE
IJ = INSULATING JOINT

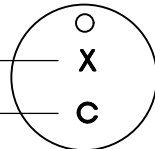

(1 TAG FOR EACH WIRE IN THE TEST BOX)

WIRE IDENTIFICATION LABELING STANDARDS

STATION NUMBER = TS - _ _ _

TS = CATHODIC PROTECTION TEST STATION BOX

XXX = SEQUENTIAL, 3 DIGIT NUMBER ASSIGNED TO EACH TEST STATION; UNIQUE TO THE ATLAS PAGE.

*SEE NOTE 1

IRWD ATLAS PAGE

*SEE NOTE 1

PIPE SIZE

XX' = DIAMETER

PIPE MATERIAL

WS = WELDED STEEL
DI = DUCTILE IRON

SYSTEM TYPE

DW = DOMESTIC WATER
RW = RECYCLED WATER
UT = UNTREATED WATER
FM = FORCE MAIN (SEWER)

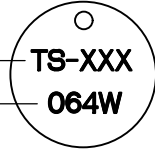

(1 TAG FOR EACH TEST BOX)

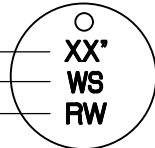

(1 TAG FOR EACH TEST BOX)

TEST BOX IDENTIFICATION LABELING STANDARDS

NOTES:

1. IRWD WILL PROVIDE THIS INFORMATION TO THE CONTRACTOR DURING THE TAG SUBMITTAL PROCESS.
2. IRWD WILL PROVIDE BLANK PLASTIC TAGS FOR EACH WIRE AND TEST BOX TO THE CONTRACTOR.
3. THE CONTRACTOR SHALL PROVIDE THE REMAINING INFORMATION, ENGRAVE THE TAGS, AND INSTALL TAGS AT EACH TEST BOX.

TEST BOX, WIRING, AND IDENTIFICATION TAGS

IRVINE RANCH WATER DISTRICT, ENGINEERING DEPARTMENT

APPROVED BY:

 KEVIN L. BURTON R.M.E. M28832
 EXECUTIVE DIRECTOR, TECHNICAL SERVICES

FEBRUARY 2025
 REVISION



**IRWD
 STD. DWG.
 CP-6**

NOT TO SCALE
 SHEET 2 OF 2

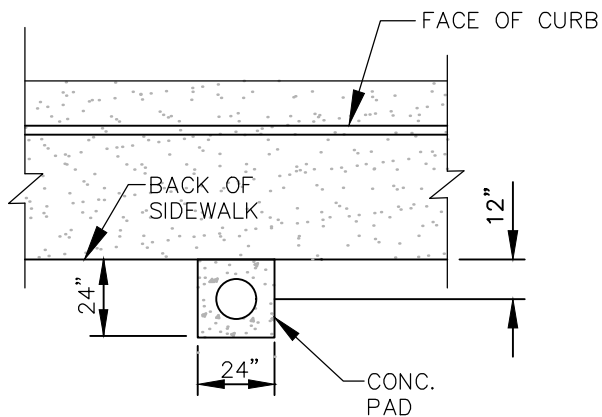

CASE I – SIDEWALK ADJACENT TO CURB

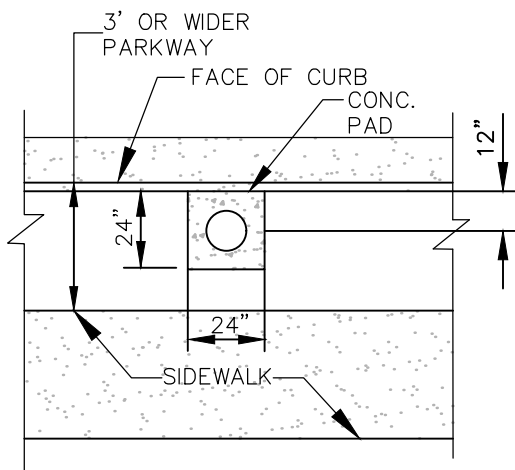

CASE II – SIDEWALK NOT ADJACENT TO CURB

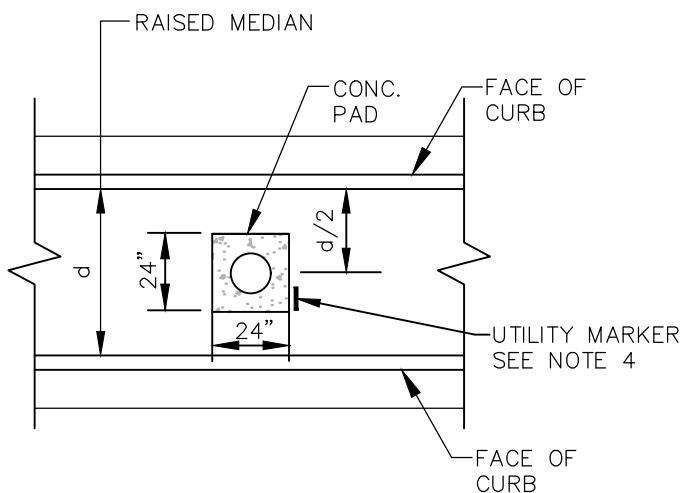

CASE III – CENTER MEDIAN

NOTES:

1. USE CASE I OR II FOR PIPE CLOSE TO THE CURB.
2. USE CASE III FOR PIPE CLOSE TO THE CENTER MEDIAN WHERE MEDIAN IS RAISED AND $d > 10'-0"$.
3. IF DIFFERENT FROM THESE THREE CASES, DISTRICT'S REPRESENTATIVE SHALL DETERMINE THE TEST BOX LOCATION.
4. INSTALL UTILITY MARKER PER IRWD STD. DWG. G-2.

TEST BOX LOCATIONS

IRVINE RANCH WATER DISTRICT, ENGINEERING DEPARTMENT

APPROVED BY:

KEVIN L. BURTON R.M.E. M28832
EXECUTIVE DIRECTOR, TECHNICAL SERVICES

FEBRUARY 2025
REVISION



Irvine Ranch
WATER DISTRICT

**IRWD
STD. DWG.
CP-7**

NOT TO SCALE
SHEET 1 OF 1

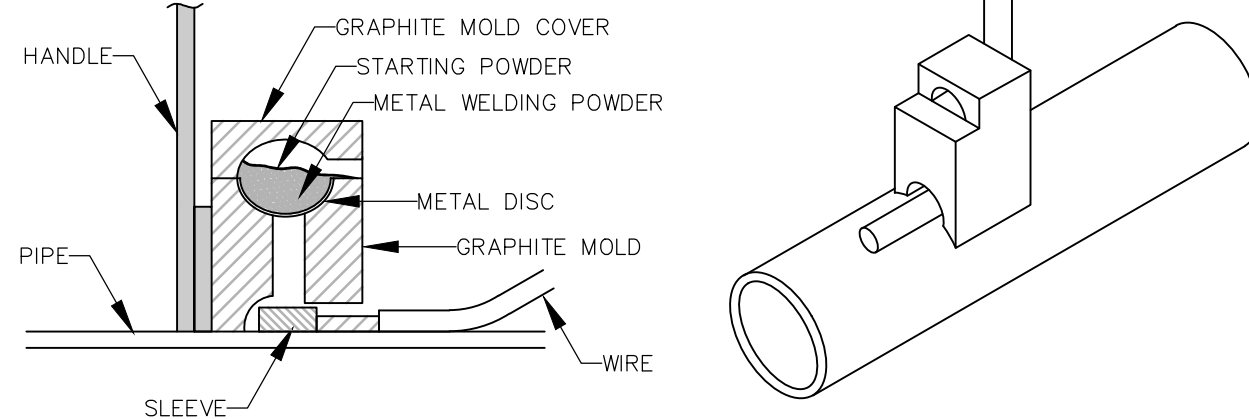

NOTES:

1. ALL WIRE WELDS SHALL BE MIN. 6" APART.
2. CAD-WELD MOLD SHOWN IS FOR HORIZONTAL SURFACES. FOR VERTICAL SURFACES SIDE WELD MOLD IS REQUIRED.

CATHODIC PROTECTION TEST STATION			
PIPE MATERIAL	WIRE SIZE	MOLD SIZE	SHOT MIX
STEEL CML&C	#8 AWG STRANDED	CAHAA-1G	CA-15
STEEL CYLINDER PIPE	#8 AWG STRANDED	CAHAA-1G	CA-15
DUCTILE IRON PIPE	#8 AWG STRANDED	CA 32X-F19	XF-19

JOINT BONDING			
PIPE MATERIAL	WIRE SIZE	MOLD SIZE	SHOT MIX
STEEL CML&C	#4 AWG STRANDED	CAHAA-1G	CA-15
STEEL CYLINDER PIPE	#4 AWG STRANDED	CAHAA-1G	CA-15
DUCTILE IRON PIPE	#4 AWG STRANDED	CA 32X-F19	XF-19

- STEP 1:** REMOVE COATING OR ENCASEMENT FROM PIPE.
- STEP 2:** FILE OR GRIND PIPE SURFACE TO BARE SHINY METAL (EQUIVALENT TO SSPC-10 "NEAR WHITE METAL") TO A MIN. SIZE OF AN AREA OF 3" X 3".
- STEP 3:** PREHEAT THE AREA TO BE CAD-WELDED WITH A PROPANE TORCH TO REMOVE ANY SURFACE MOISTURE (DO NOT OVER HEAT).
- STEP 4:** STRIP 1" OF INSULATION FROM END OF CP TEST WIRE.
- STEP 5:** WRAP TEST LEAD WIRE ONCE AROUND OUTSIDE CIRCUMFERENCE OF PIPE THEN TIE WIRE INTO A "HALF HITCH" KNOT APPROXIMATELY 12" AWAY FROM CAD-WELD AREA. LEAVE 12" OR MORE OF WIRE (SLACK) BETWEEN KNOT AND CAD-WELD (THIS WILL HELP PREVENT FUTURE DAMAGE TO CAD-WELD).
- STEP 6:** INSTALL APPROPRIATE CAD-WELD PROTECTIVE SLEEVE ONTO SPECIFIC AWG WIRE SIZE. (REFER TO TABLES HEREON).
- STEP 7:** SELECT CORRECT CAD-WELD GRAPHITE MOLD AND APPROPRIATE WELDING POWDER FOR THE SIZE AND TYPE OF WIRE AND METALLIC PIPE THAT IS TO BE WELDED (REFER TO TABLES HEREON).
- STEP 8:** INSPECT AND CLEAN THE GRAPHITE MOLD.
- STEP 9:** INSERT CAD-WELD DISC IN BOTTOM OF GRAPHITE MOLD, POUR ENTIRE CONTENTS OF SHOT (ALUMINO-THERMIC WELD POWDER AND STARTER) INTO GRAPHITE MOLD.
- STEP 10:** PLACE WIRE IN THE CENTER OF THE CLEANED AREA SO THAT ALL OF THE STRIPPED WIRE IS IN CONTACT WITH THE PIPE SURFACE.
- STEP 11:** PLACE LOADED GRAPHITE MOLD OVER WIRE AND HOLD FIRMLY IN PLACE.
- STEP 12:** POSITION YOURSELF (AND ANY OTHER PERSONNEL) AT LEAST 90° AWAY FROM IGNITION PORT OPENING.
- STEP 13:** HOLD FLINT GUN AT IGNITION PORT AND IGNITE STARTING POWDER.
- STEP 14:** REMOVE GRAPHITE MOLD FROM PIPE AFTER CAD-WELD COMBUSTION HAS STOPPED.
- STEP 15:** REMOVE SLAG FROM WELD AREA USING A WELDING PEEN HAMMER.
- STEP 16:** GRASP WIRE AND APPLY TENSION TO WIRE WHILE STRIKING WELD WITH A 2 LBS. HAMMER TO CHECK SOUNDNESS OF WELD. (BE CAUTIOUS OF DAMAGE TO INTERIOR OF PIPE LINING.)
- STEP 17:** COAT WIRE, CAD-WELD, AND EXPOSED PIPE SURFACE WITH APPROVED CONNECTION COATING PER IRWD STD. SPEC. SECTION 16640.
- STEP 18:** REPLACE PIPE COATING AND PLASTIC WRAP OR TAPE IF REQUIRED.

ALUMINO-THERMIC (CAD) WELDING

IRVINE RANCH WATER DISTRICT, ENGINEERING DEPARTMENT

APPROVED BY:

Kevin L. Burton

KEVIN L. BURTON R.M.E. M28832
EXECUTIVE DIRECTOR, TECHNICAL SERVICES

FEBRUARY 2025
REVISION



**IRWD
STD. DWG.
CP-8**

NOT TO SCALE
SHEET 1 OF 1

ALUMINO-THERMIC WELD PER IRWD
STD. SPEC. SECTION 16640 AND
IRWD STD. DWG. CP-8 (TYP.)

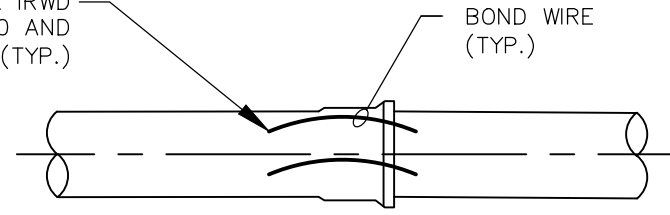

BELL AND SPIGOT PIPE JOINT

ALUMINO THERMIC WELD
PER IRWD STD. SPEC.
SECTION 16640 AND IRWD
STD. DWG. CP-8 (TYP.)

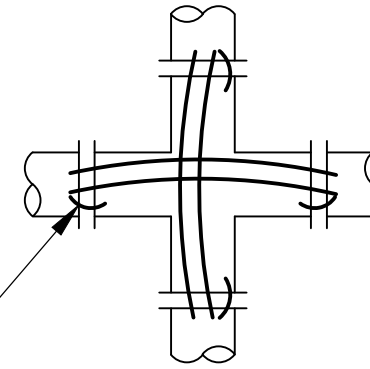

CROSS

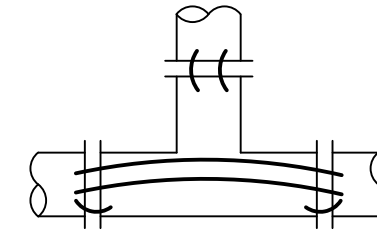

TEE

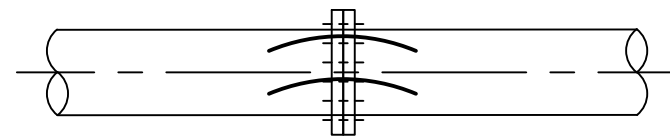

FLANGED OR MECHANICAL PIPE JOINT

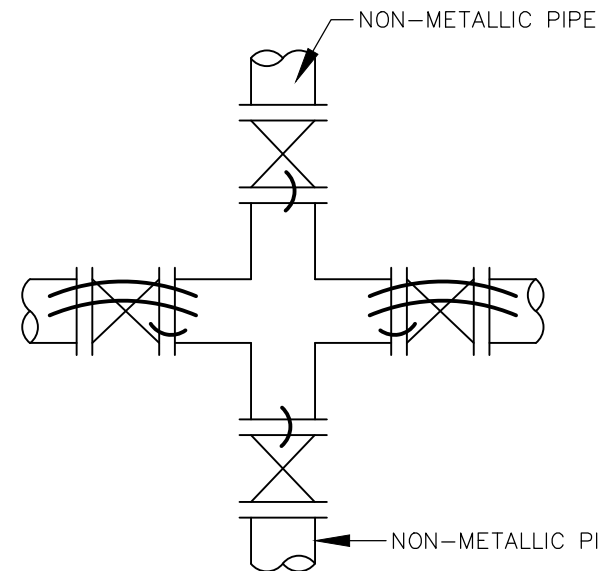

VALVE CROSSING

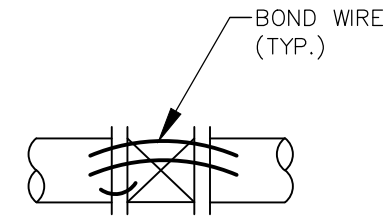

VALVE



ADAPTER AND FLEXIBLE COUPLING

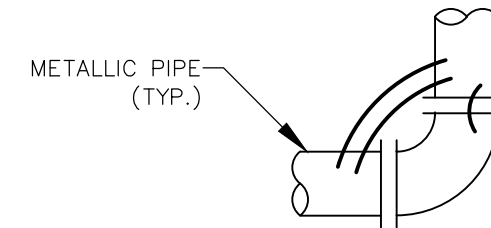

BEND

NOTES:

1. ALL WIRE WELDS SHALL BE MIN. 6" APART.
2. BOND WIRES SHALL NOT BE INSTALLED ACROSS INSULATING JOINTS.
3. COAT WELD PER IRWD STD. SPEC. SECTION 16640.
4. THREE BOND WIRES ARE REQUIRED FOR PIPE DIAMETERS 18" OR LARGER.
5. ALL BOND WIRES SHALL BE AS SPECIFIED IN IRWD STD. SPEC. SECTION 16640.
6. BOND WIRES AT VALVE CROSSING SHALL BE WELDED AT A DISTANCE OF 6" FROM FACE OF FLANGE.
7. BOND WIRES SHALL BE AWG NO. 4 STRANDED COPPER WIRE.

BONDING FOR PIPE JOINTS AND FITTINGS

IRVINE RANCH WATER DISTRICT, ENGINEERING DEPARTMENT

APPROVED BY:

KEVIN L. BURTON R.M.E. M28832
EXECUTIVE DIRECTOR, TECHNICAL SERVICES

FEBRUARY 2025
REVISION



Irvine Ranch
WATER DISTRICT

IRWD
STD. DWG.
CP-9

NOT TO SCALE
SHEET 1 OF 1

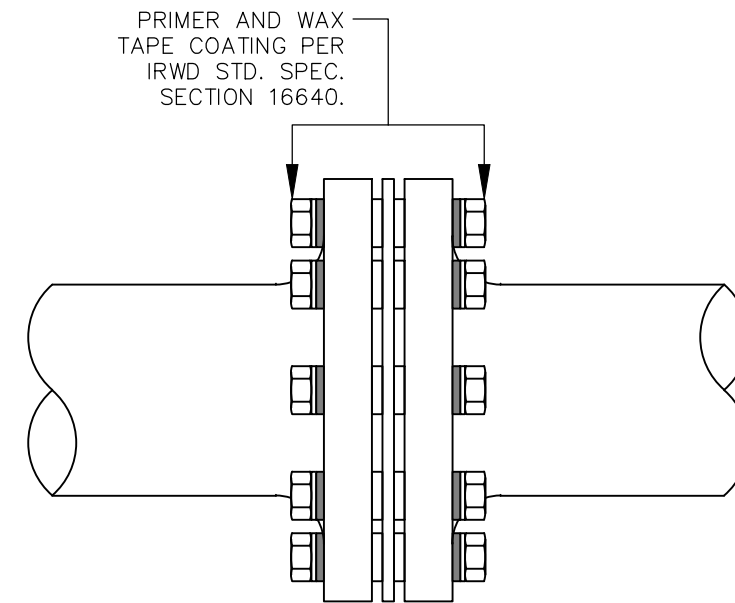
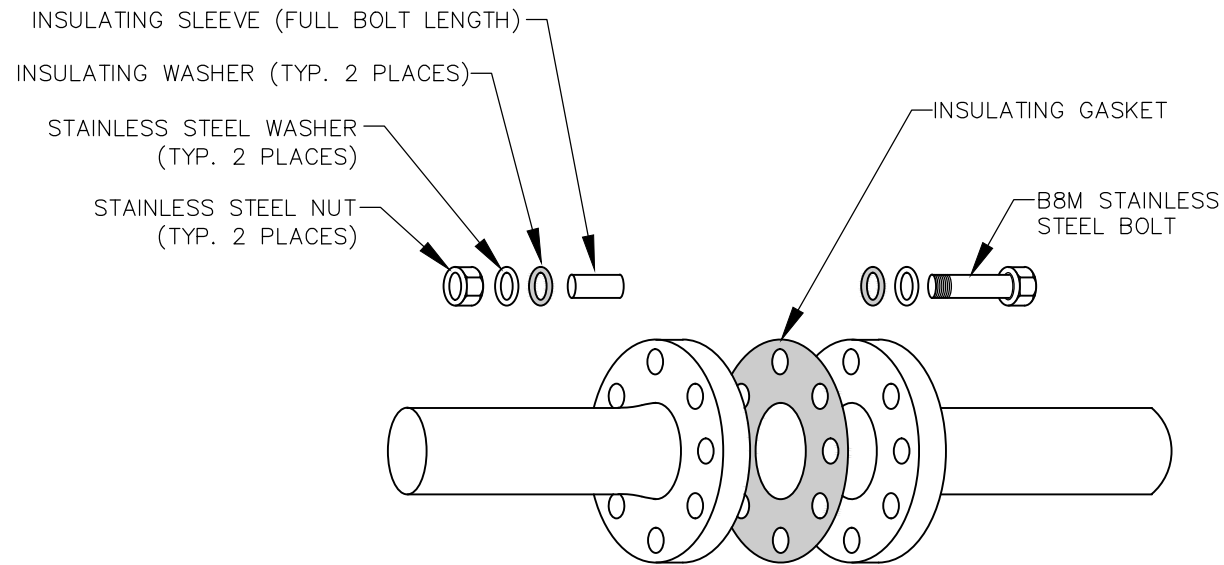

BURIED INSULATING FLANGE COATING

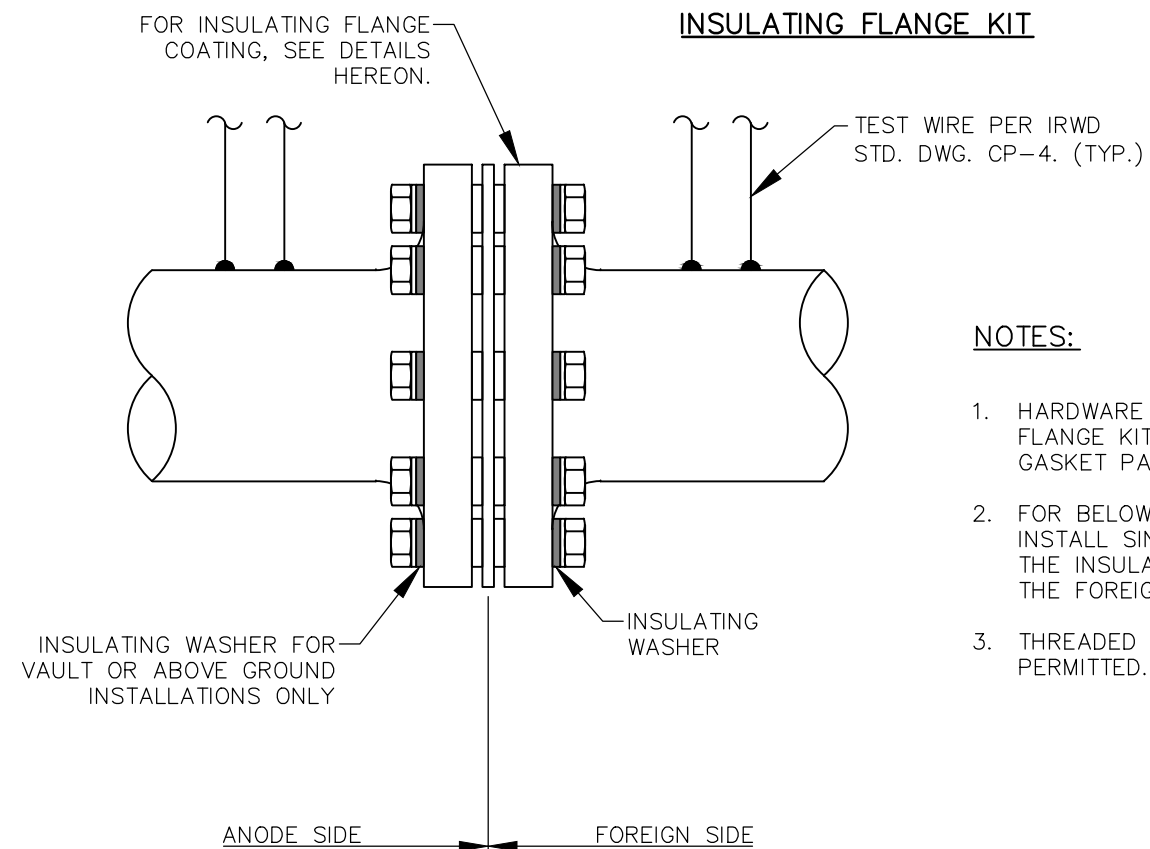

INSULATING FLANGE KIT

NOTES:

1. HARDWARE QUANTITIES IN INSULATING FLANGE KIT WILL VARY BASED ON GASKET PATTERN AND PIPE SIZE.
2. FOR BELOW GROUND INSTALLATIONS, INSTALL SINGLE-WASHER KITS WITH THE INSULATING WASHERS ONLY ON THE FOREIGN SIDE OF THE FLANGES.
3. THREADED STUD STYLE KITS ARE NOT PERMITTED.

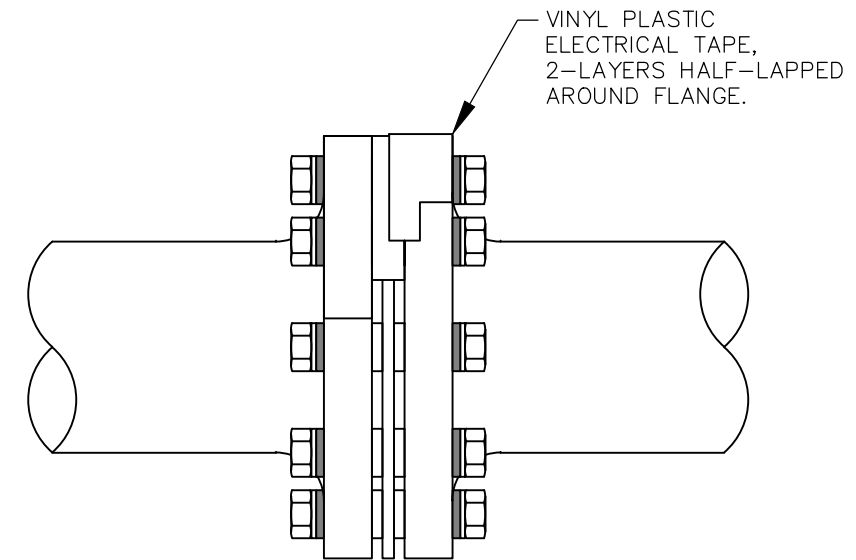

ABOVE GROUND INSULATING FLANGE COATING

INSULATING JOINT

IRVINE RANCH WATER DISTRICT, ENGINEERING DEPARTMENT

APPROVED BY:

Kevin L. Burton

KEVIN L. BURTON R.M.E. M28832
EXECUTIVE DIRECTOR, TECHNICAL SERVICES

FEBRUARY 2025
REVISION



IRWD
STD. DWG.
CP-10

NOT TO SCALE
SHEET 1 OF 1

TABLE OF CONTENTS

General Standard Drawings

NUMBER	DESCRIPTION	DATE
G-1	Removable Guard Post	Feb 2025
G-2	Utility Marker	Feb 2025
G-3	Access Gate	Feb 2025
G-4	Retaining Wall	Feb 2025
G-5	Vault Ladder	Feb 2025
G-6	Vault Sumps	Feb 2025
G-7	Vault Vent	Feb 2025
G-8	Wall Penetration for $2\text{-}1/2" < \text{Pipe} < 4"$	Feb 2025
G-9	Wall Penetration for $\text{Pipe} \geq 4"$	Feb 2025
G-10	Concrete Slope Anchors	Feb 2025

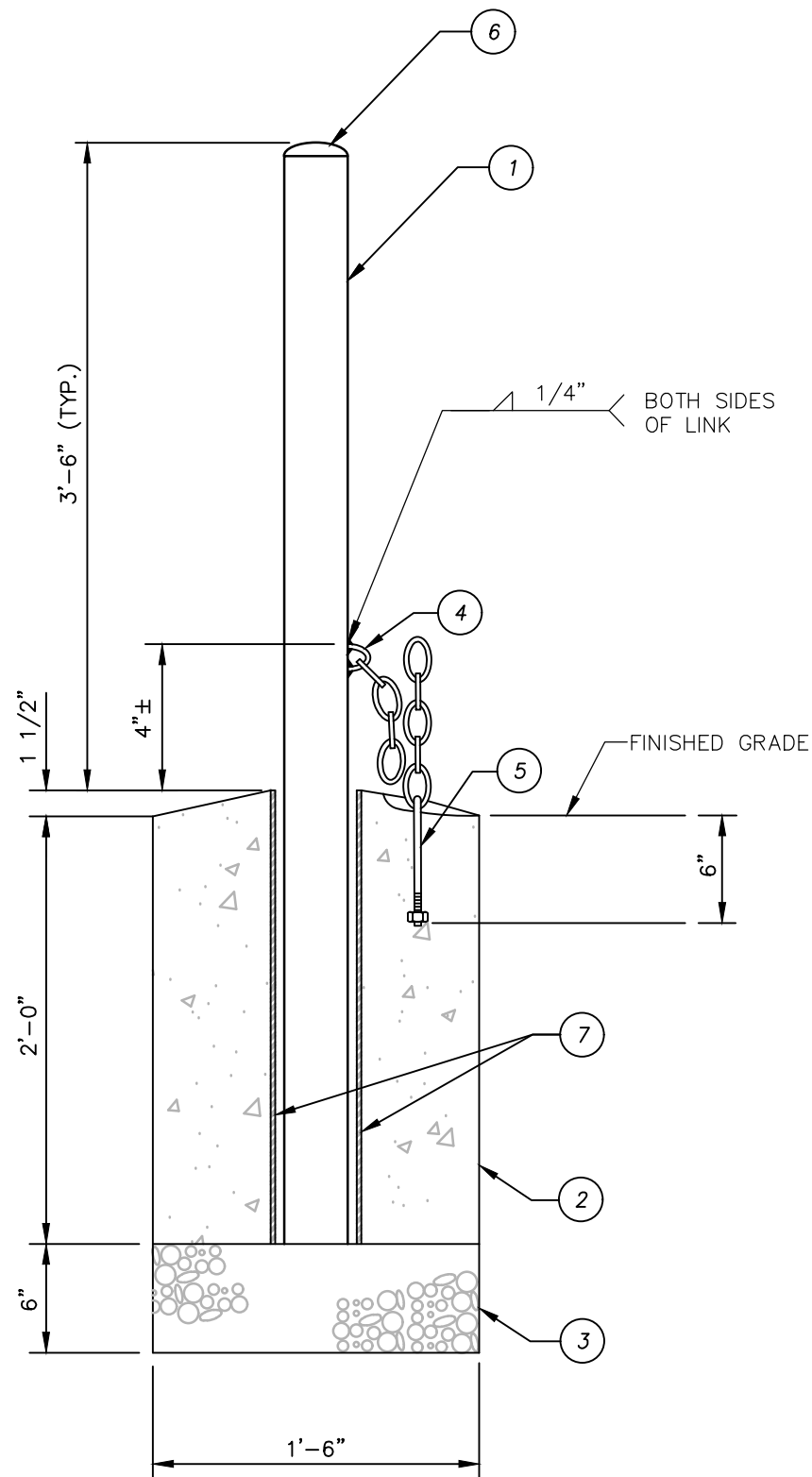

SECTION A-A

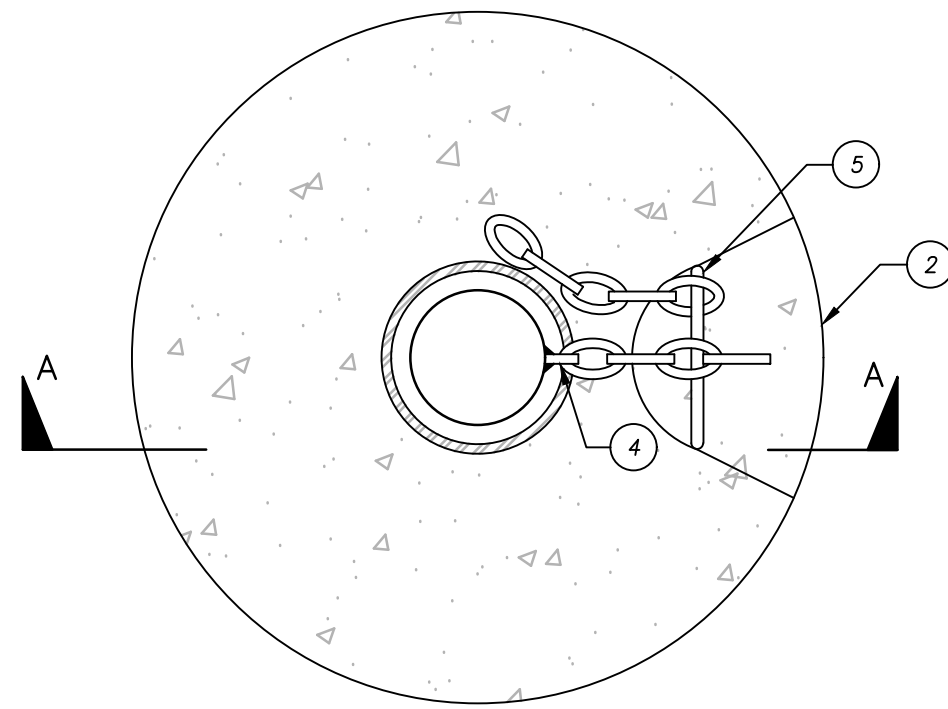

PLAN VIEW

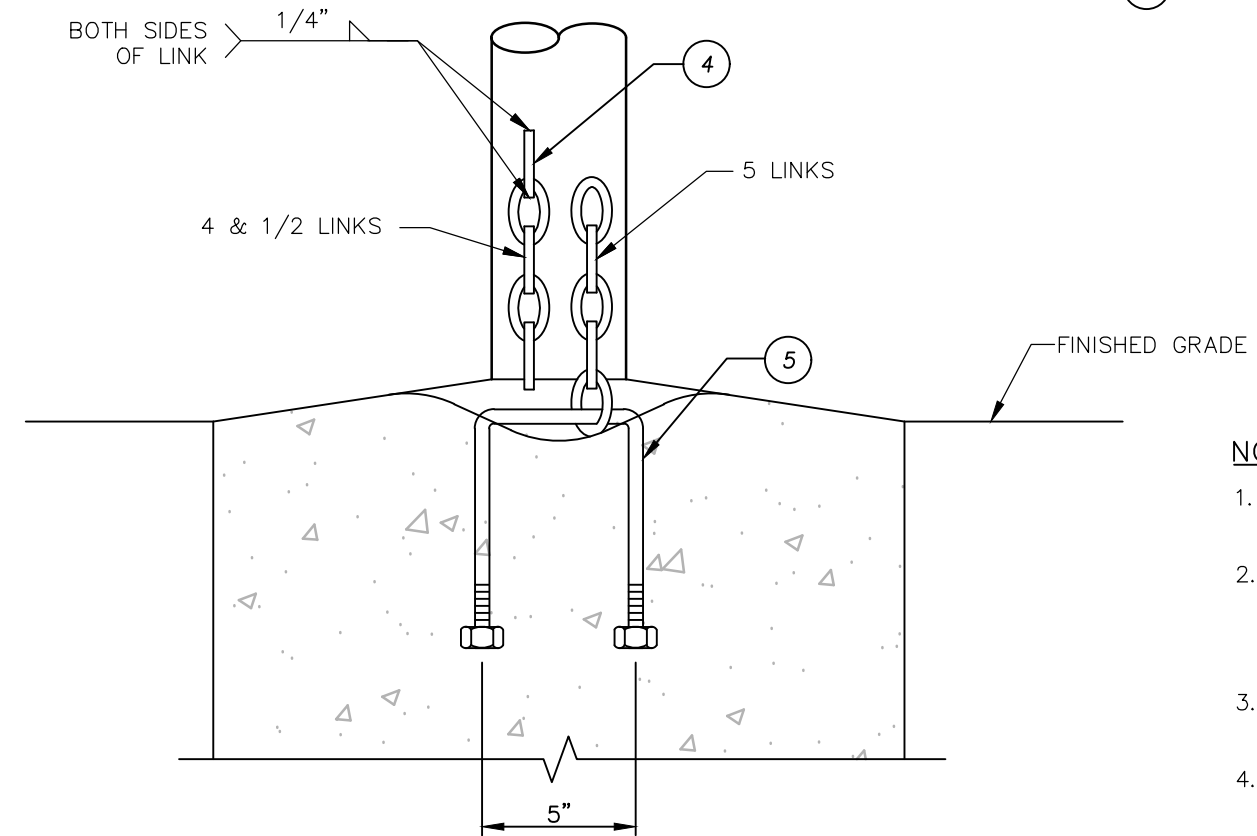

FRONT VIEW

ITEM	MATERIALS
1	4" SCH 40 BLACK STEEL PIPE.
2	ANNULAR CONCRETE POST ANCHOR. CAST IN PLACE.
3	3/4" CRUSHED ROCK.
4	LOCKING ASSEMBLY MADE OF 4 & 1/2 LINKS OF 3/8" GRADE 80 STAINLESS CHAIN. WELD THE 1/2 LINK TO POST.
5	EMBED 3/8" DIA. 5" WIDE STAINLESS STEEL U-BOLT WITH NUTS EMBEDDED INTO CONCRETE POST ANCHOR. LOOP 5 LINK STAINLESS CHAIN SEGMENT OF 3/8" GRADE 80 CHAIN ONTO U-BOLT AS SHOWN IN DETAIL. SEE NOTE 2.
6	4" SCH 40, WELDED STEEL END CAP.
7	5" SCH 40, HOT DIP GALVANIZED STEEL PIPE SLEEVE.

NOTES:

1. PAINT GUARD POST AND CAP OSHA SAFETY YELLOW PER IRWD STD. SPEC. SECTION 09900.
2. TROWEL CONCRETE POST ANCHOR SURFACE TO DRAIN AWAY FROM STEEL SLEEVE. SHAPE THE U-BOLT SWALE TO MINIMIZE THE PROTRUSION ABOVE THE ADJACENT CONCRETE SURFACE TO ELIMINATE THE TRIPPING HAZARD.
3. ORIENT THE U-BOLT TO FACE THE DOWN STREAM SURFACE DIRECTION.
4. LOCK POST IN PLACE WITH IRWD APPROVED SOLID BRASS PAD LOCK.

REMOVABLE GUARD POST

IRVINE RANCH WATER DISTRICT, ENGINEERING DEPARTMENT

APPROVED BY:

Kevin L. Burton

KEVIN L. BURTON R.M.E. M28832
EXECUTIVE DIRECTOR, TECHNICAL SERVICES

FEBRUARY 2025
REVISION



IRWD
STD. DWG.
G-1

NOT TO SCALE
SHEET 1 OF 1

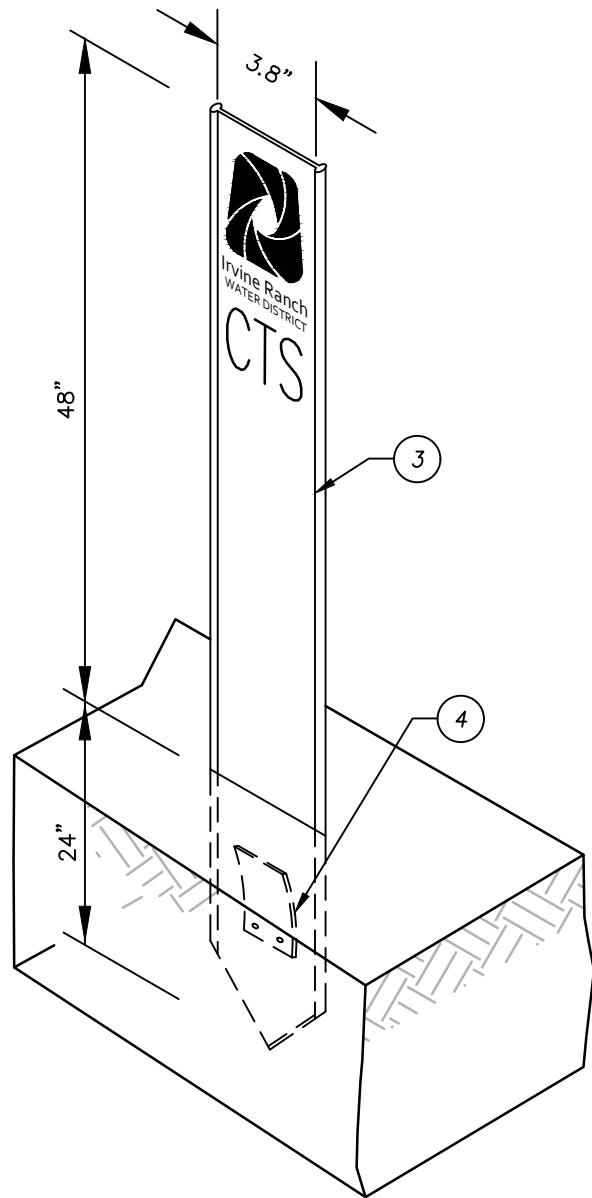
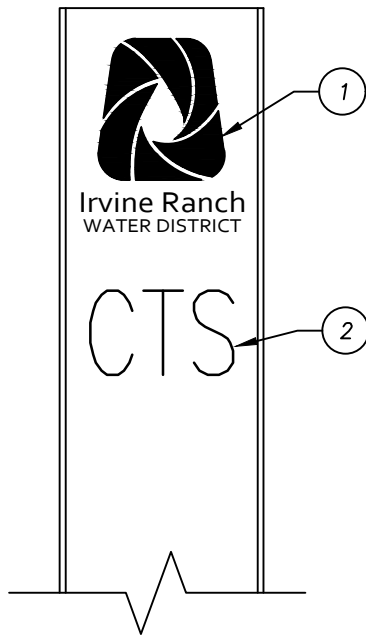

ABBREVIATIONS

- ABD ANODE BED / ANODE WELL
- AVR AIR AND VACUUM RELEASE VALVE
- BO BLOW OFF
- CBL DIRECT BURIED CABLE
- CTS CATHODIC PROTECTION TEST STATION
- EPB ELECTRICAL PULL BOX
- FO FLUSH-OUT
- IJ INSULATING JOINT
- MH MANHOLE
- MTR METER
- PRV PRESSURE REGULATING VALVE
- PZ PIEZOMETER
- SBX SHUNT BOX
- SCO SEWER CLEAN OUT
- SWR SEWER MAIN
- TFO TEMPORARY FLUSH-OUT
- TPB TELEMETRY PULL BOX
- TW TEST WELL
- VLT VAULT
- VLV VALVE
- WTR WATER MAIN
- WQS WATER QUALITY SAMPLE STATION

ITEM MATERIALS

- (1) — IRWD LOGO DECAL 3.25" HIGH X 2.75" WIDE.
- (2) — 2 OR 3 CHARACTER FACILITY LABEL. YELLOW LETTERS (1" HIGH) ON A CLEAR SELF ADHESIVE DECAL (USE ABBREVIATIONS HEREON).
- (3) — POST SHALL BE "CARSONITE" MODEL: CIB-380 MATERIAL: COLORED FIBERGLASS COMPOSITE WIDTH: 3.8" LENGTH: 72" COLOR: BROWN
- (4) — SPRING-LOADED STEEL BARB ANCHOR, FACTORY ATTACHED WITH RIVETS.

UTILITY MARKER

IRVINE RANCH WATER DISTRICT, ENGINEERING DEPARTMENT

APPROVED BY:

KEVIN L. BURTON R.M.E. M28832
EXECUTIVE DIRECTOR, TECHNICAL SERVICES

FEBRUARY 2025
REVISION



Irvine Ranch
WATER DISTRICT

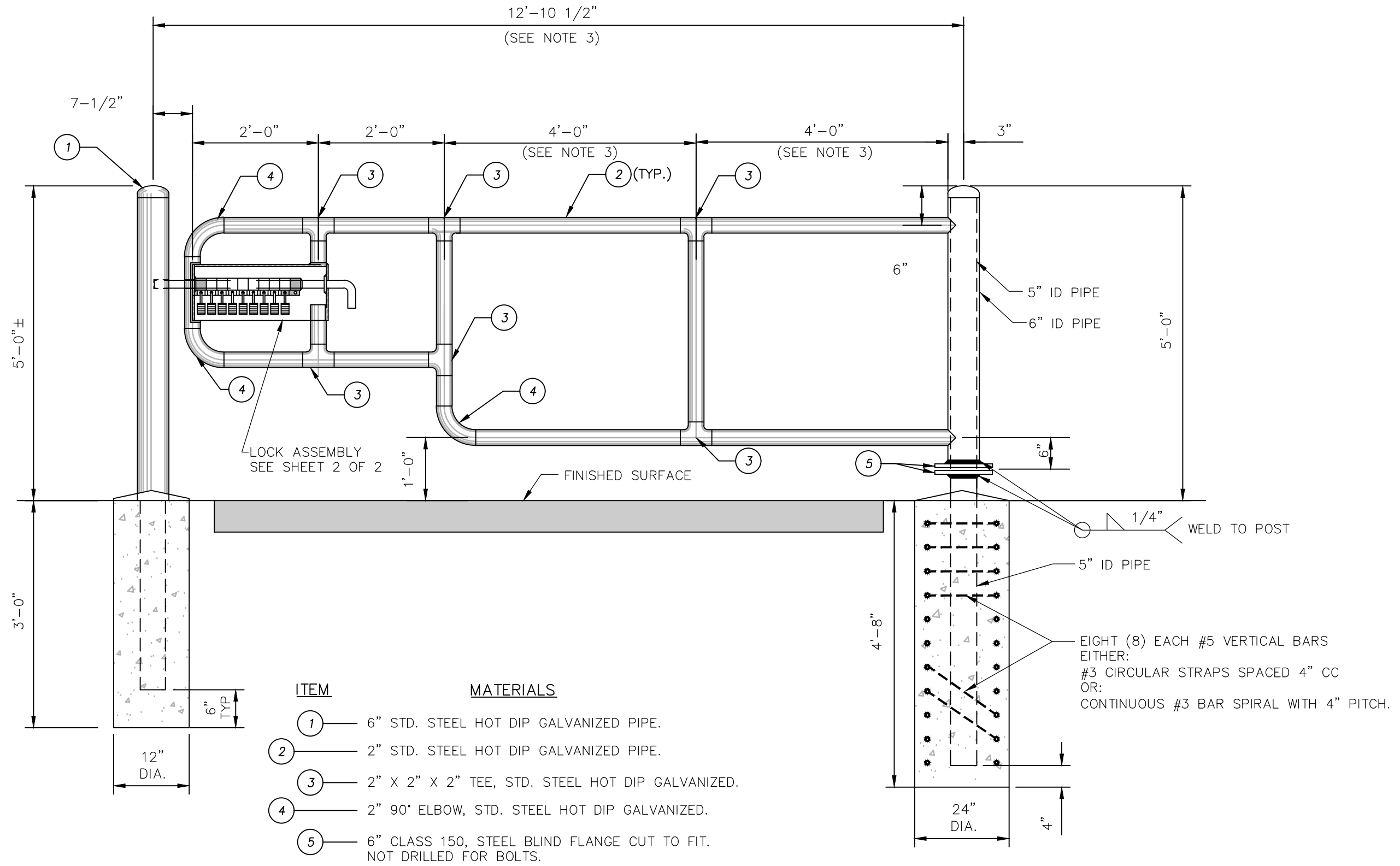

**IRWD
STD. DWG.
G-2**

NOT TO SCALE
SHEET 1 OF 1



NOTES:

1. COAT OR HOT DIP GALVANIZE PER IRWD STD. SPEC. SECTION 09900.
2. SET GATE TOP BAR LEVEL. SET POST SO THAT ELEVATION OF POST TOPS ARE EQUAL.
3. INCREASE DIMENSION TO SPAN ROAD WIDTH (UP TO MAX. TOTAL SPAN OF 17').

ACCESS GATE		 IRWD STD. DWG. G-3
IRVINE RANCH WATER DISTRICT, ENGINEERING DEPARTMENT APPROVED BY:  KEVIN L. BURTON R.M.E. M28832 EXECUTIVE DIRECTOR, TECHNICAL SERVICES		
FEBRUARY 2025 REVISION		NOT TO SCALE SHEET 1 OF 2

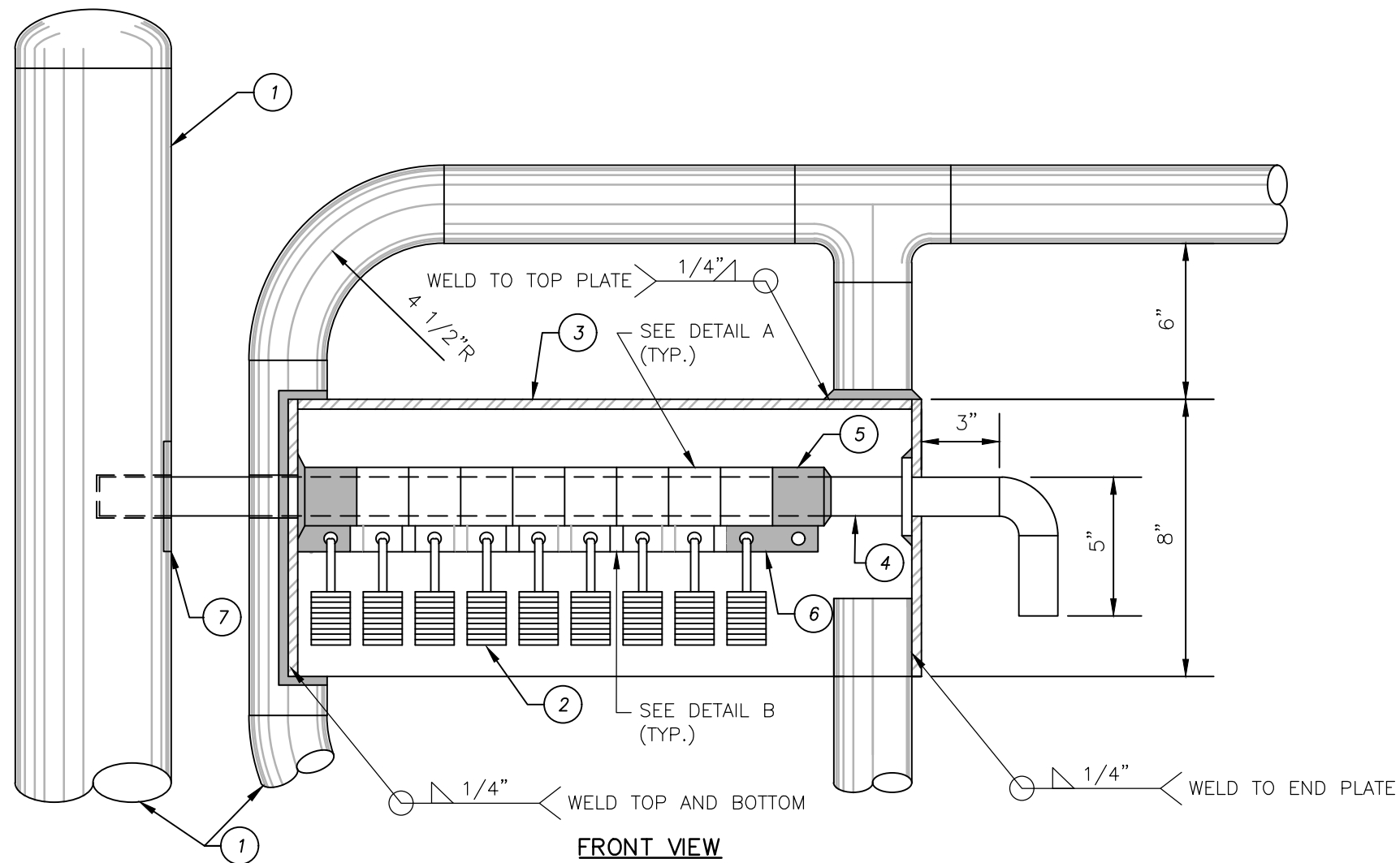

FRONT VIEW

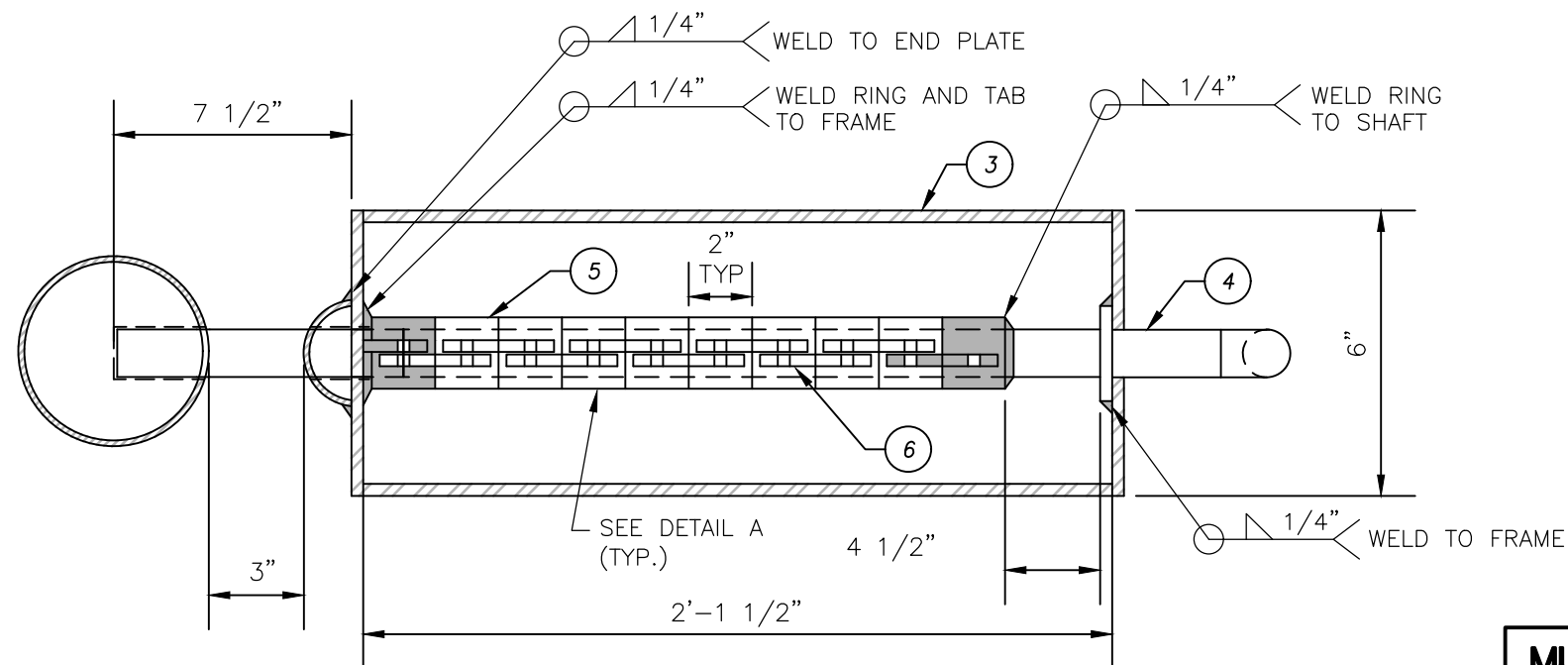

BOTTOM VIEW

- | ITEM | MATERIALS |
|------|---|
| 1 | GATE FRAME. SEE SHEET 1 OF 2. |
| 2 | NO. 5 SOLID BRASS PADLOCKS AS APPROVED BY IRWD. |
| 3 | 1/4" THICK PLATE METAL BOX COVERING LOCKS. ACCESS TO LOCKS FROM BOTTOM ONLY. |
| 4 | 1-1/2" DIA. STD. STEEL PIPE. LOCK ASSEMBLY SHAFT. |
| 5 | 2" STD. STEEL PIPE COUPLING. 2" LONG AS SHAFT RING COUPLING. WELD THE TWO RINGS AT THE END TO THE PIPE SHAFT AND THE METAL BOX, RESPECTIVELY, AS SHOWN. |
| 6 | 1/4" STEEL PLATE, 3-1/2" LONG BY 1" WIDE AS A LOCK TAB. WELD TO SHAFT RINGS AS SHOWN. |
| 7 | 4" VERTICAL SLOT. |

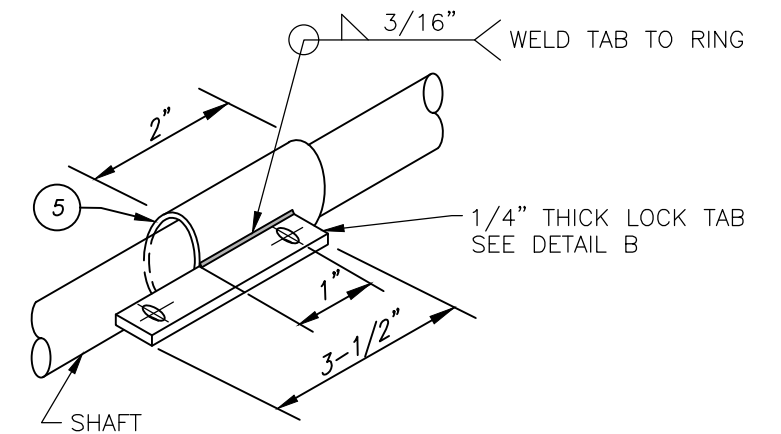

DETAIL A

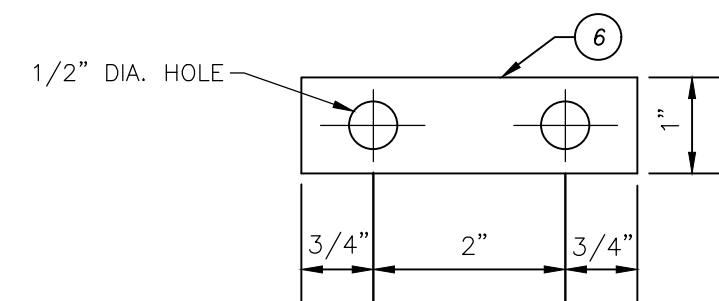

DETAIL B

NOTE:

COAT OR HOT DIP GALVANIZE PER IRWD STD. SPEC. SECTION 09900.

MULTI-LOCK GATE ASSEMBLY

IRVINE RANCH WATER DISTRICT, ENGINEERING DEPARTMENT

APPROVED BY:

Kevin L. Burton

KEVIN L. BURTON R.M.E. M28832
EXECUTIVE DIRECTOR, TECHNICAL SERVICES

FEBRUARY 2025
REVISION



Irvine Ranch
WATER DISTRICT

IRWD
STD. DWG.
G-3

NOT TO SCALE
SHEET 2 OF 2

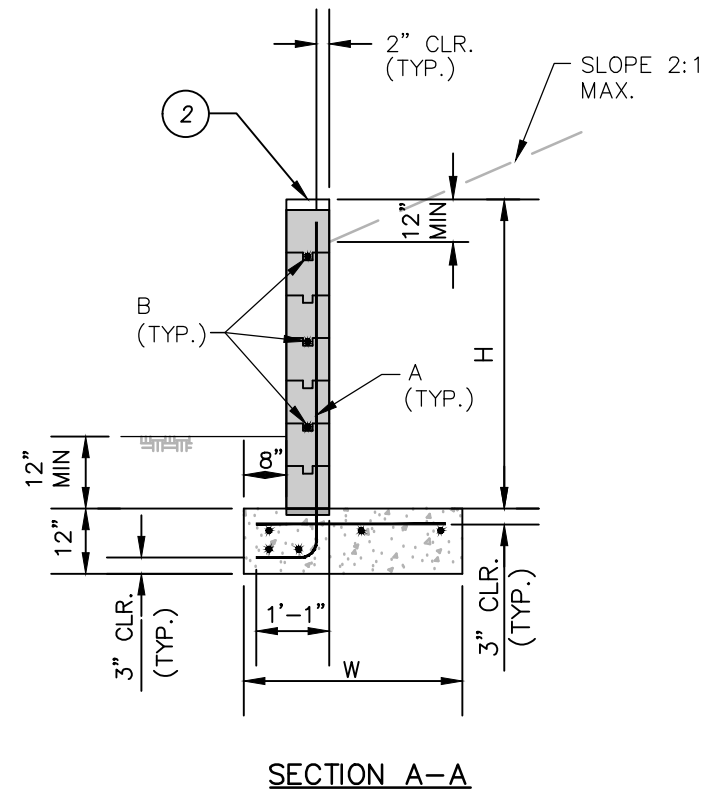
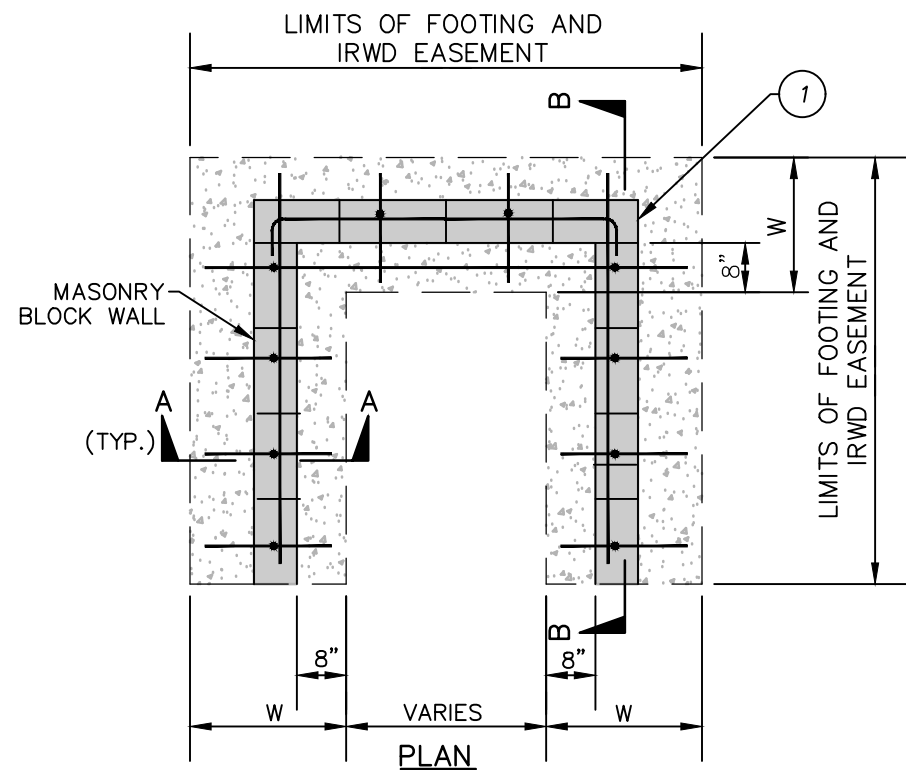

ITEM MATERIALS

- ① MASONRY BLOCK WALL, SEE NOTE 2.
- ② BLOCK CAP, MATCH MASONRY BLOCK WALL STYLE AND COLOR.

NOTES:

1. RETAINING WALL TO BE CONSTRUCTED WITH ALL IRWD APPURTENANCES WHEN A SLOPE EXISTS AT THE LOCATION OF THE APPURTENANCES. EXAMPLES INCLUDE CLEAN-OUTS, BACKFLOW DEVICES, FIRE HYDRANTS, AIR/VACS, FLUSH-OUTS, METERS, PRV STATIONS, TEST STATIONS, MANHOLES, VAULTS, VALVES AND WHEREVER REQUIRED BY THE DISTRICT REPRESENTATIVE.
 - A. CLEARANCE BETWEEN INSIDE WALL FACE AND THE OUTERMOST EDGE OF ANY IRWD APPURTENANCE SHALL BE 36" MIN.
 - B. SEE IRWD STD. DWG. W-15 FOR SPECIFIC PRESSURE REDUCING STATION CLEARANCE REQUIREMENTS.
 - C. FOR POWERED APPURTENANCES, SUCH AS TRANSFORMERS, REFER TO THE SCE MIN. CLEARANCE REQUIREMENTS.
 - D. SEWER MANHOLES REQUIRE ADDITIONAL WALL LENGTH TO PROVIDE EQUIPMENT ACCESS. MIN. LENGTH FOR MANHOLES (INSIDE, FROM WALL FACE TO WALL FACE IS 13').
2. MASONRY BLOCK SHALL BE 8" X 8" X 16" UNITS CONFORMING TO ASTM C-90 CLASS "S" AND CONCRETE MASONRY ASSOCIATION STANDARDS. BLOCK SHALL BE "SPLIT FACE" BEIGE COLOR FINISH ON ALL EXPOSED FACES. FILL ALL CELLS WITH GROUT.
3. MORTAR AND GROUT SHALL MATCH BLOCKWORK AND BE IN CONFORMANCE WITH IRWD STD. SPECIFICATIONS AND SECTION 202-2 OF THE STANDARD SPECIFICATIONS FOR PUBLIC WORKS CONSTRUCTION.
4. OMIT MORTAR FROM THE FIRST VERTICAL JOINT OF THE BLOCK COURSE ABOVE FINISH GRADE TO PROVIDE WEEP HOLES FOR SUB-DRAINAGE PURPOSES.
5. CONCRETE SHALL BE CLASS 560-C-3250.
6. WALL CONSTRUCTION SHALL MEET IRWD STD. SPECIFICATIONS.
7. PROVIDE RAILING ON TOP OF WALL WHEN REQUIRED BY CODE.
8. PROVIDE WATERPROOFING ON EXTERIOR OF BURIED PORTION OF WALL PER IRWD STD. SPEC. SECTION 03345.

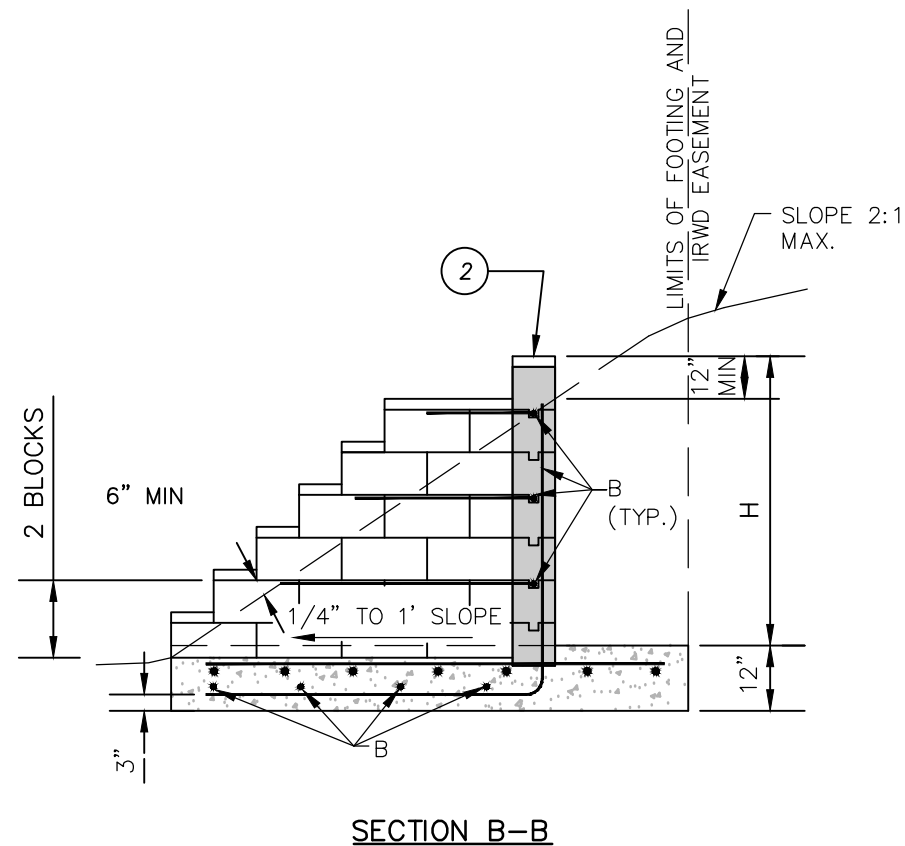

REINFORCEMENT TABLE					
DESIGN H	3'-4"	4'-0"	4'-8"	5'-4"	6'-0"
DESIGN W	2'-8"	3'-0"	3'-4"	3'-8"	4'-0"
A VERT. REINF.	#4@16"	#4@16"	#5@16"	#6@16"	#6@16"
B VERT. REINF.	#4@16"	#4@16"	#5@16"	#6@16"	#6@16"
DESIGN CRITERIA:					
1. EQUIVALENT FLUID PRESSURE = 35 PCF (TOE AND HEEL)					
2. ALLOWABLE BEARING CAPACITY = 1500 PSF					

RETAINING WALL

IRVINE RANCH WATER DISTRICT, ENGINEERING DEPARTMENT
 APPROVED BY:

 KEVIN L. BURTON R.M.E. M28832
 EXECUTIVE DIRECTOR, TECHNICAL SERVICES

FEBRUARY 2025
 REVISION



**IRWD
 STD. DWG.
 G-4**
 NOT TO SCALE
 SHEET 1 OF 1

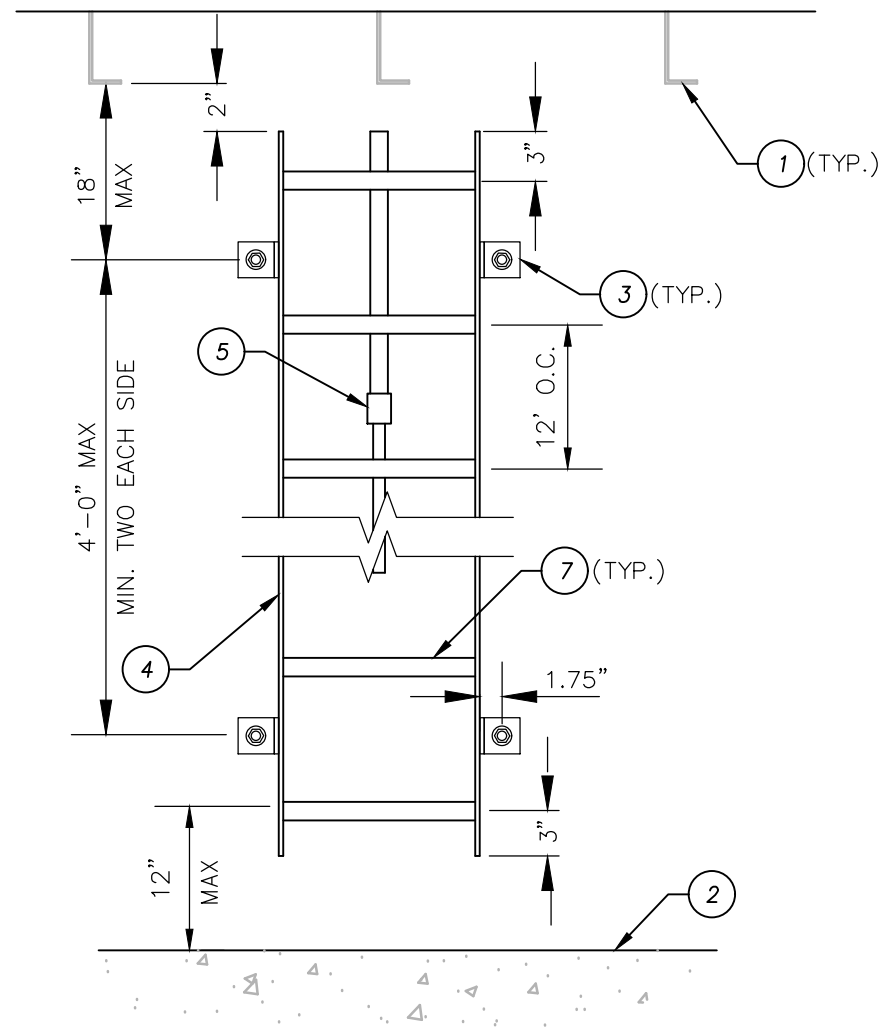

FRONT VIEW
CENTER SAFETY POST OPTION

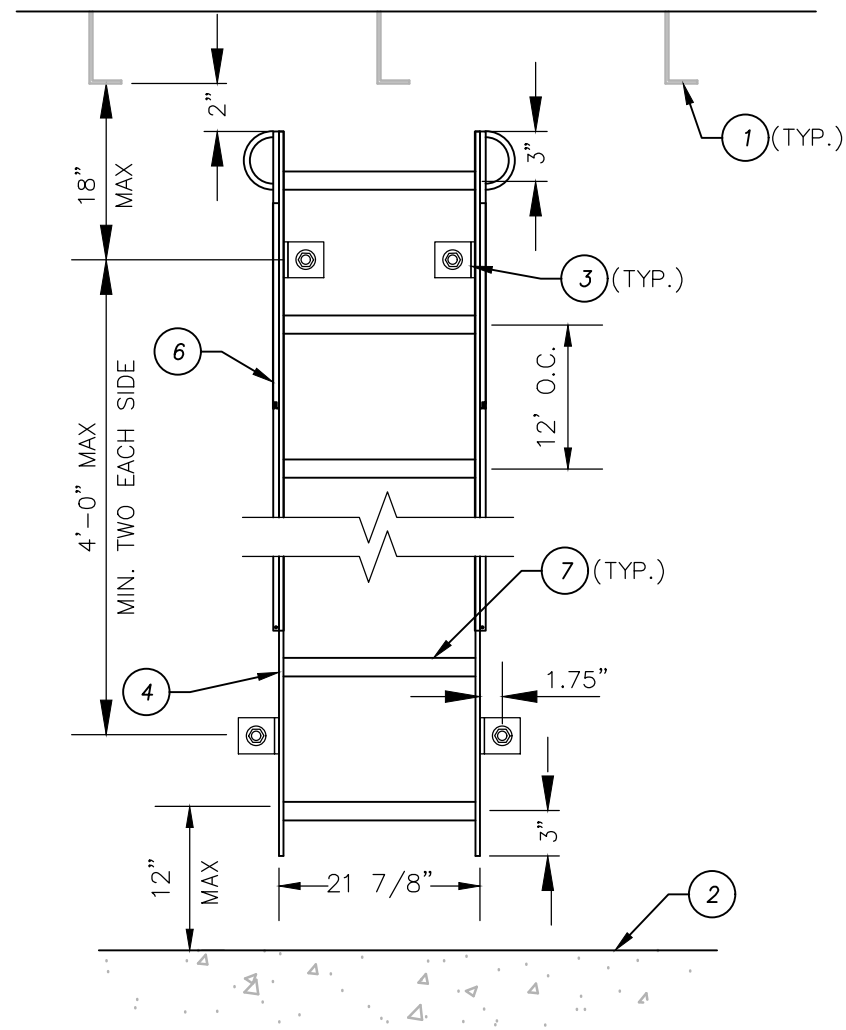

FRONT VIEW
DOUBLE HANDRAIL OPTION

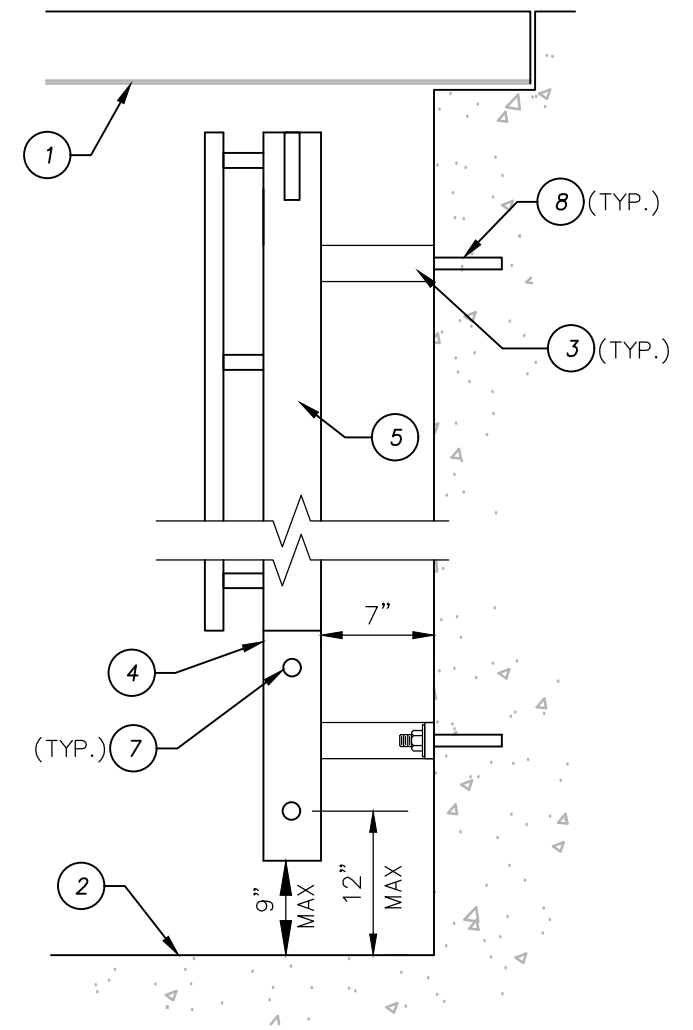

SIDE VIEW
(DOUBLE HANDRAIL OPTION SHOWN)

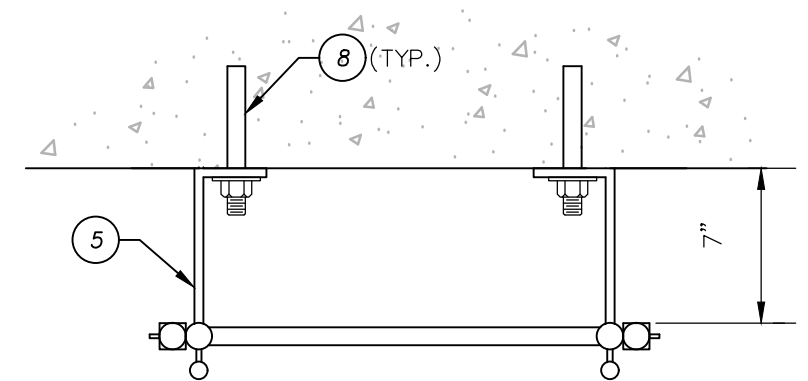

TOP VIEW
(DOUBLE HANDRAIL OPTION SHOWN)

ITEM	MATERIALS
1	BOTTOM OF GRATING OR HATCH.
2	FLOOR OF VAULT.
3	INSTALL 3" X 3/8" X 7" BRACKET.
4	INSTALL 2" X 3/8" RUNNER BAR.
5	INSTALL CENTER SAFETY POST PER IRWD STD. SPEC. SECTION 05120.
6	INSTALL DOUBLE HANDRAIL PER IRWD STD. SPEC. SECTION 05120.
7	INSTALL 3/4" ROUND BAR KNURLED RUNGS @ 12" O.C., PLUG WELD INTO RUNNERS.
8	CONCRETE: INSTALL 3/4" DIA. HILTI KB TZ (WITH 4-3/4" MIN. EMBED) MASONRY: INSTALL 3/4" DIA. HILTI KB3 (WITH 4-3/4" MIN. EMBED)

- NOTES:**
- ALL SURFACES AND WELDS SHALL BE GROUND SMOOTH AND CLEANED AFTER FABRICATION.
 - ALL JOINTS SHALL BE WELDED PER AMERICAN WELDING SOCIETY STANDARDS, LATEST REVISION.
 - HOT DIP GALVANIZE AFTER FABRICATION.
 - ALL CONNECTING AND MOUNTING HARDWARE SHALL BE TYPE 316 STAINLESS STEEL.

VAULT LADDER

IRVINE RANCH WATER DISTRICT, ENGINEERING DEPARTMENT
 APPROVED BY:

 KEVIN L. BURTON R.M.E. M28832
 EXECUTIVE DIRECTOR, TECHNICAL SERVICES

FEBRUARY 2025
 REVISION

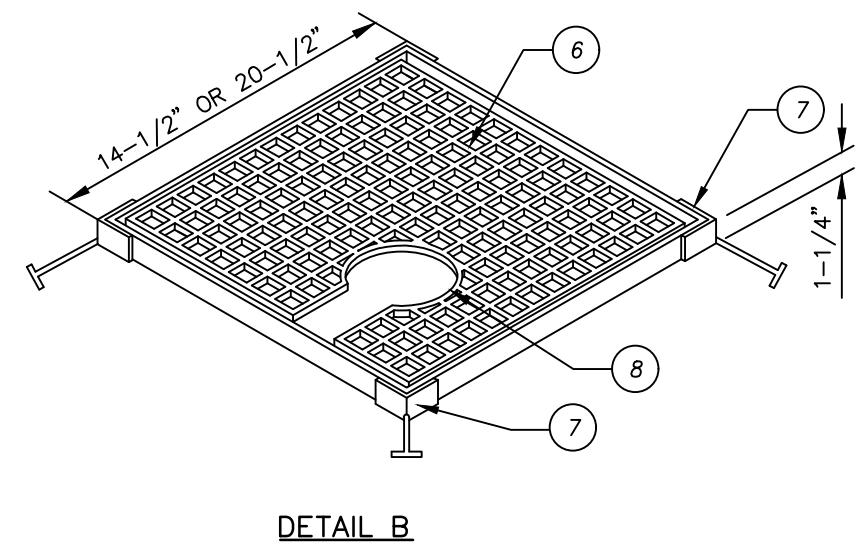
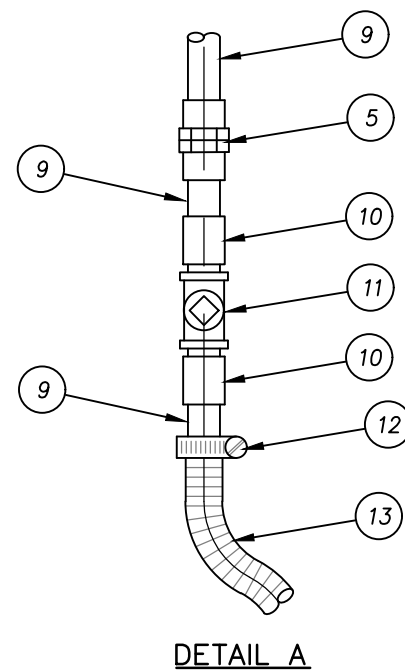
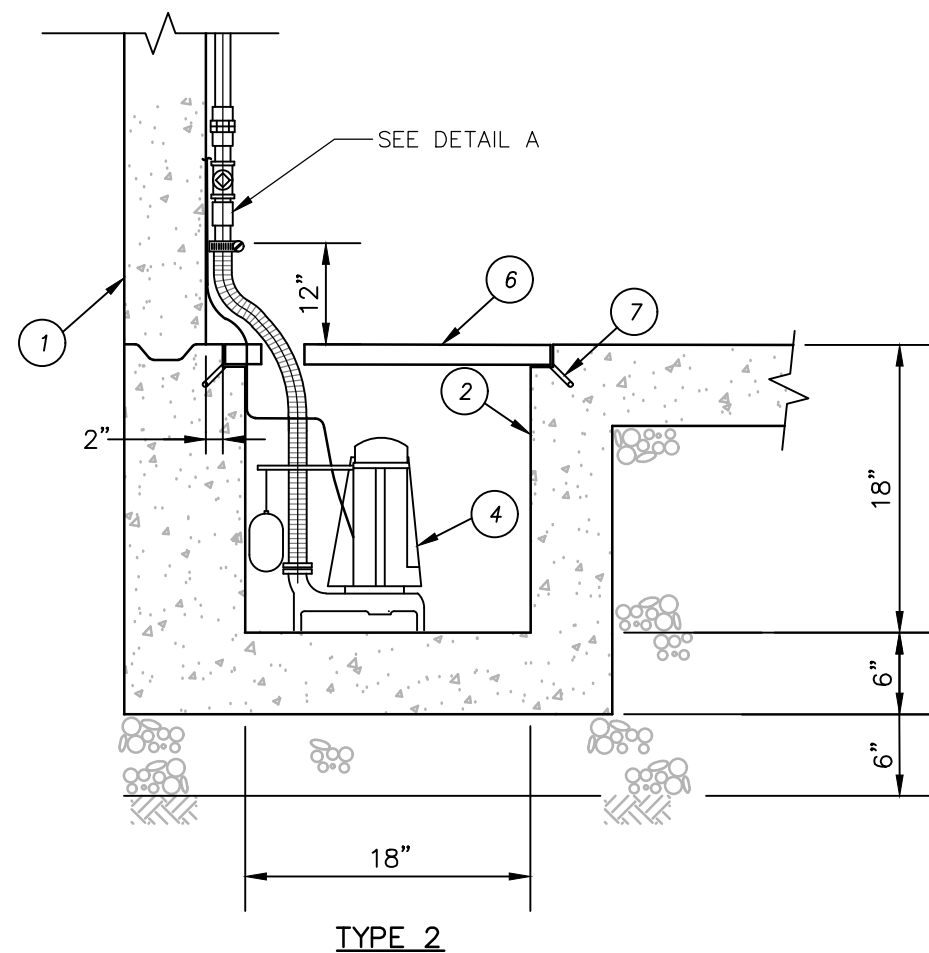
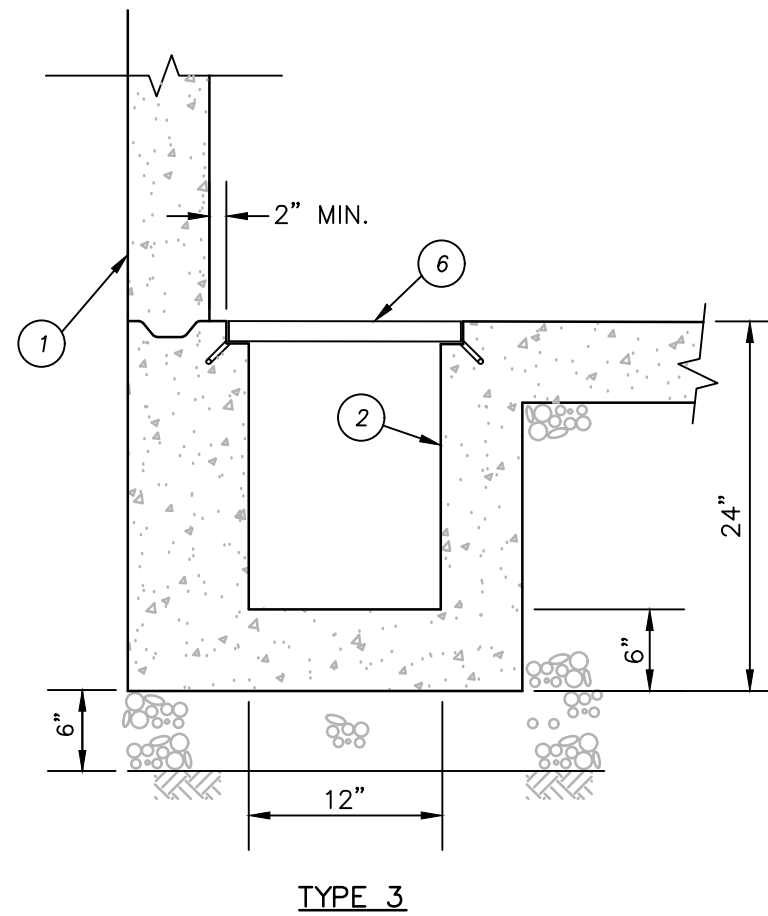
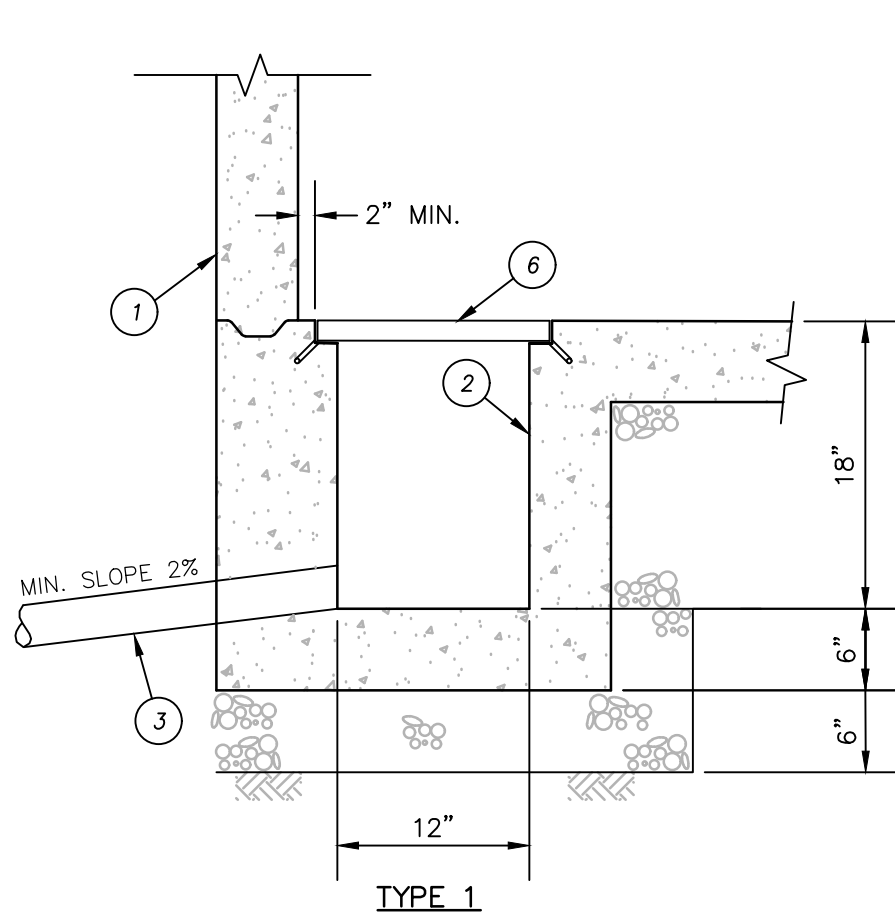

IRWD
STD. DWG.
G-5
NOT TO SCALE
SHEET 1 OF 1



ITEM	MATERIALS
1	PRECAST REINFORCED CONCRETE VAULT.
2	12" X 12" OR 18" X 18" X 24" DEEP RECESSED REINFORCED CONCRETE SUMP. MIN. WALL THICKNESS = 6".
3	4" SCH 80 PVC DRAIN PIPE. CONNECT TO DRAINAGE SYSTEM ACCEPTABLE TO IRWD.
4	SUMP PUMP PER IRWD STD. DWG. W-15 (E-3) WHEN DRAIN PIPE OPTION IS NOT AVAILABLE. CONNECT TO DRAINAGE SYSTEM ACCEPTABLE TO IRWD.
5	2" SCH 80 PVC UNION, SLIP X SLIP.
6	14" X 14" OR 20" X 20" X 1" THICK FIBER GRATE INLET, SEE DETAIL B.
7	1-1/2" X 1-1/2" X 1/4" FIBER REINFORCED PLASTIC ANGLE FRAME WITH EMBEDMENT ANCHOR AT EACH CORNER. SERIES 1625 OR APPROVED EQUAL.
8	PROVIDE 4" HOLE IN GRATE AND NOTCH-OUT USING 4" HOLE SAW TO ACCOMMODATE 2" PIPE (FOR TYPE 2 ONLY).
9	2" SCH 80 PVC PIPE. SECURED TO VAULT WALL WITH STAINLESS STEEL PIPE CLAMPS, ONE CLAMP EACH 3' OF PIPE.
10	2" SCH 80 PVC ADAPTER, SLIP X M.I.P.T.
11	2" BRASS SWING CHECK VALVE, F.I.P.T. BOTH ENDS.
12	STAINLESS STEEL HOSE CLAMP.
13	2" STAINLESS STEEL REINFORCED PVC HOSE.

NOTES:

- INSTALLATION OF TYPE 3 SUMPS REQUIRES PRIOR WRITTEN IRWD APPROVAL.
- RECYCLED WATER VAULTS SHALL USE TYPE 3 SUMPS ONLY.
- VAULT FLOOR AND SUMP SHALL CONSIST OF ONE PRECAST SECTION.

VAULT SUMPS

IRVINE RANCH WATER DISTRICT, ENGINEERING DEPARTMENT
 APPROVED BY:

 KEVIN L. BURTON R.M.E. M28832
 EXECUTIVE DIRECTOR, TECHNICAL SERVICES

FEBRUARY 2025
 REVISION

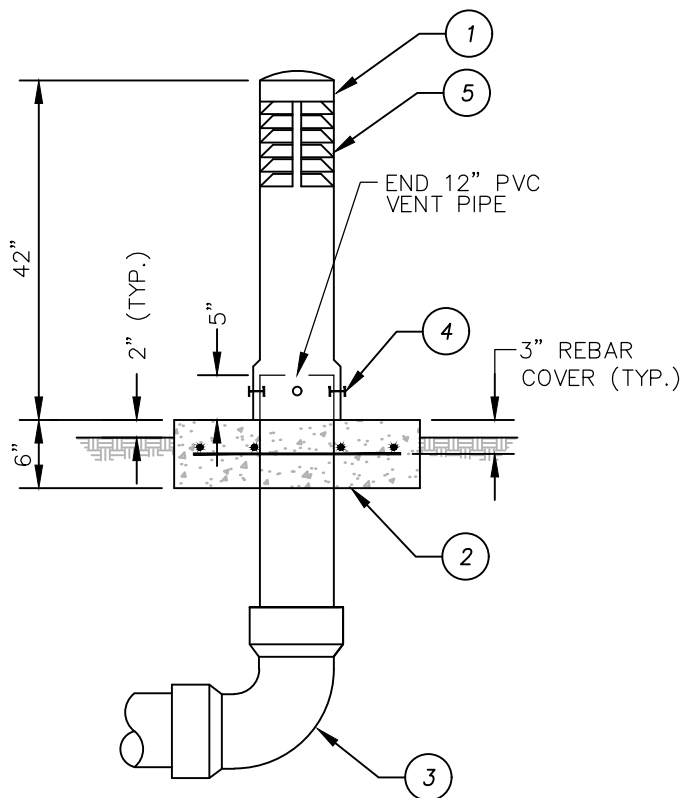

IRWD
 STD. DWG.
 G-6
 NOT TO SCALE
 SHEET 1 OF 1



ITEM MATERIALS

- ① — 12" DIA. LLDPE PIPE VENT PER IRWD STD. SPEC. SECTION 15089.
- ② — CONSTRUCT 36" SQ. CONCRETE SLAB (TYP.) WITH 4 EACH #4'S EACH WAY, AS SHOWN. PROVIDE 3" REBAR COVER IN 560-C-3250 CONCRETE MIX.
- ③ — INSTALL 12" DIA. SCH 80 PVC VENT PIPE WITH BENDS AND CONNECTIONS BELOW GRADE AS REQUIRED.
- ④ — CONNECT VENT AT 4 PLACES WITH 3/8" DIA. X 1-1/2" TYPE 316 STAINLESS STEEL SELF-TAPPING SCREW. DRILL THRU PVC DUCT AND VENT STACK BELL.
- ⑤ — INSTALL STAINLESS STEEL BUG SCREEN AT INTERIOR OF VENT OPENINGS.

VAULT VENT

IRVINE RANCH WATER DISTRICT, ENGINEERING DEPARTMENT

APPROVED BY:

KEVIN L. BURTON R.M.E. M28832
EXECUTIVE DIRECTOR, TECHNICAL SERVICES

FEBRUARY 2025
REVISION



Irvine Ranch
WATER DISTRICT

**IRWD
STD. DWG.
G-7**

NOT TO SCALE
SHEET 1 OF 1

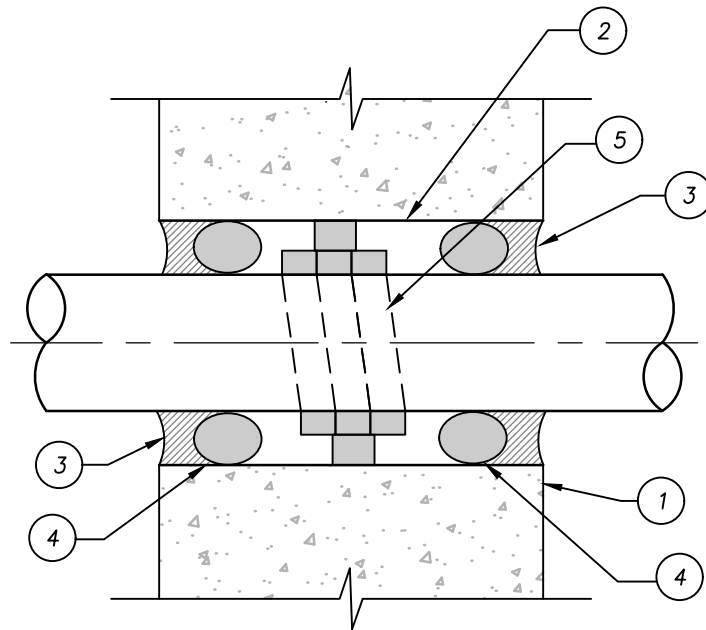

- | <u>ITEM</u> | <u>MATERIALS</u> |
|-------------|--|
| ① | VAULT WALL OR STRUCTURAL MEMBER. |
| ② | ANNULAR SPACE 1" MIN. ALL AROUND. |
| ③ | SIKAFLEX ELASTOMERIC SEALANT. APPLY A MIN. OF 3/4" OF SEALANT OUTSIDE BACKER ROD, SEE NOTE 2. |
| ④ | "CLOSED CELL" POLYETHYLENE FOAM BACKER ROD. |
| ⑤ | INSTALL GREENSTREAK HYDROPHILIC WATERSTOP MATERIAL "SWELL-STOP". MIN. 3 COIL WRAPS AROUND OUTSIDE OF CONDUIT OR PIPE AS REQUIRED FOR A SNUG INITIAL FILL OF THE ANNULAR SPACE. |

NOTES:

1. BACKER ROD AND SEALANT TO BE INSTALLED ON BOTH SIDES OF "SWELL STOP" MATERIAL.
2. CEMENTITIOUS OR OTHER RIGID GROUT MATERIAL SHALL NOT BE ALLOWED FOR SEALING OR COVERING THE ANNULAR OPENING ON EITHER SIDE.
3. SEE IRWD STD. DWG. G-9 FOR WALL PENETRATION FOR PIPE 4" IN DIA. AND GREATER AND IRWD STD. SPEC. SECTION 03462 FOR WALL PENETRATIONS FOR PIPE 2-1/2" IN DIA. AND SMALLER.

WALL PENETRATION FOR 2-1/2" < PIPE < 4"

IRVINE RANCH WATER DISTRICT, ENGINEERING DEPARTMENT

APPROVED BY:

 KEVIN L. BURTON R.M.E. M28832
 EXECUTIVE DIRECTOR, TECHNICAL SERVICES

FEBRUARY 2025
 REVISION



Irvine Ranch
WATER DISTRICT

**IRWD
STD. DWG.
G-8**

NOT TO SCALE
 SHEET 1 OF 1

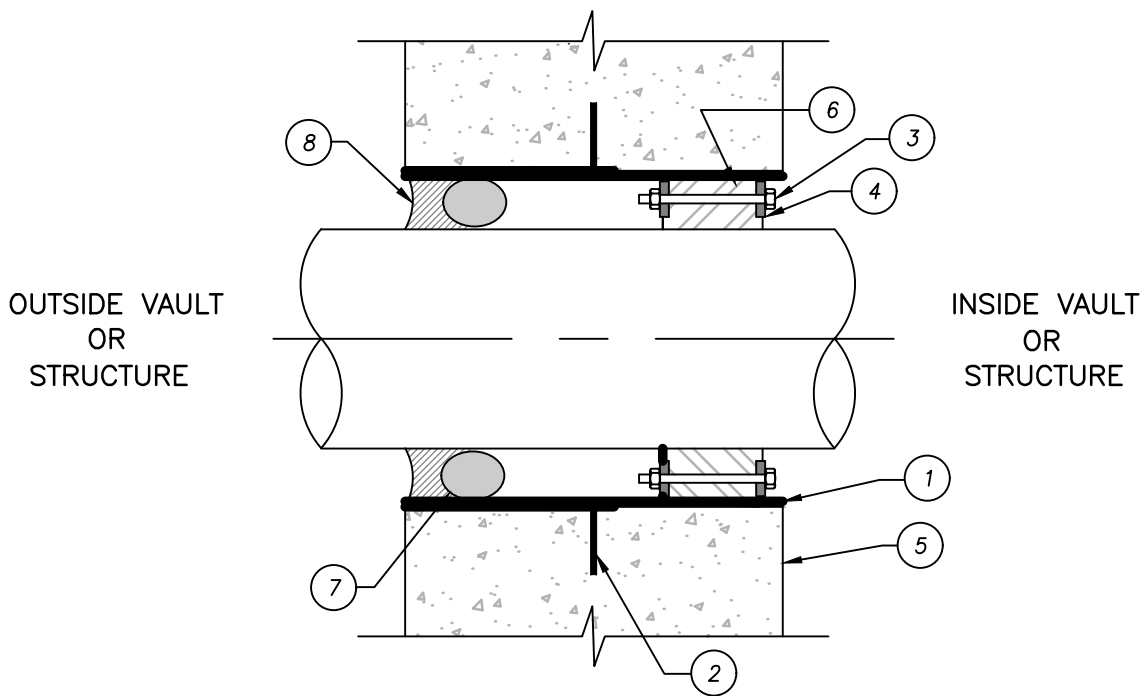

ITEM MATERIALS

- ① — WALL SLEEVE. SEE NOTE 1.
- ② — ANCHOR COLLAR/2" WATER STOP.
- ③ — S.S. HEX BOLT, NUT AND WASHER (TYP.).
- ④ — PRESSURE PLATE.
- ⑤ — VAULT WALL OR STRUCTURAL MEMBER.
- ⑥ — EPDM ELASTOMERIC COMPRESSION SEAL ELEMENT.
- ⑦ — "CLOSED CELL" POLYETHYLENE FOAM BACKER ROD.
- ⑧ — SIKAFLEX ELASTOMERIC SEALANT. APPLY A MIN. OF 3/4" OF SEALANT OUTSIDE BACKER ROD, SEE NOTE 2.

NOTES:

1. WALL SLEEVE SHALL BE HOT DIPPED GALVANIZED STEEL OR HDPE ONE-PIECE PRE-MOLDED SLEEVE, PROVIDED THAT IT HAS AN INTEGRAL WATER-STOP RING AND IS CAST INTO THE WALL OR STRUCTURAL ELEMENT.
2. BACKER ROD AND SEALANT TO BE INSTALLED ON "OUTSIDE" OF STRUCTURE.
3. CEMENTITIOUS OR OTHER RIGID GROUT MATERIAL SHALL NOT BE ALLOWED FOR SEALING OR COVERING THE ANNULAR OPENING ON EITHER SIDE.

WALL PENETRATION FOR PIPE ≥ 4"

IRVINE RANCH WATER DISTRICT, ENGINEERING DEPARTMENT

APPROVED BY:

Kevin L. Burton
 KEVIN L. BURTON R.M.E. M28832
 EXECUTIVE DIRECTOR, TECHNICAL SERVICES

FEBRUARY 2025
 REVISION



Irvine Ranch
 WATER DISTRICT

IRWD
 STD. DWG.
 G-9

NOT TO SCALE
 SHEET 1 OF 1

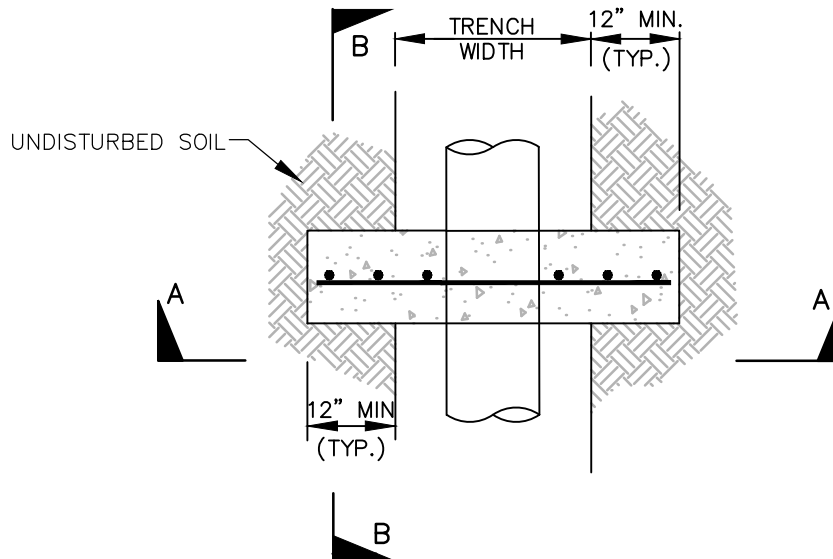

PLAN VIEW

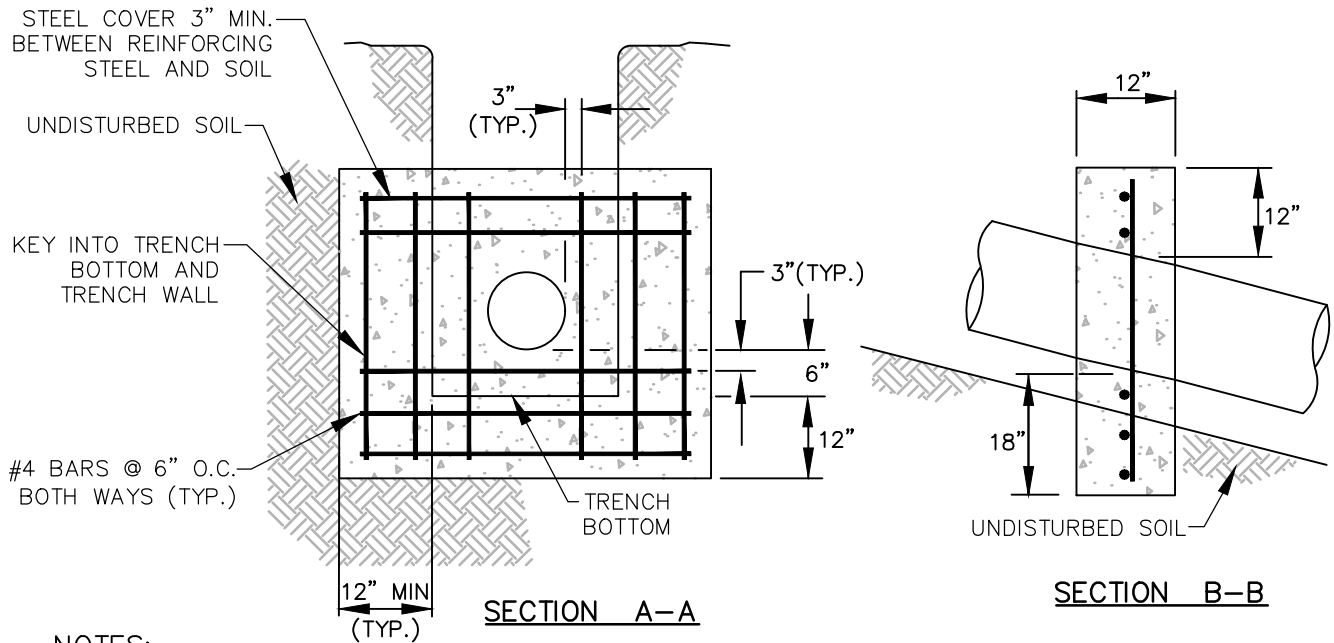

NOTES:

1. ANCHORS SHALL BE REQUIRED FOR PIPE SLOPES EXCEEDING 33% ($S > 0.33$) IN UNPAVED CONDITIONS.
2. ANCHORS SHALL BE PLACED AT ONE PER PIPE LENGTH, NOT TO EXCEED A SLOPE DISTANCE OF 18'.
3. CONCRETE SHALL BE CLASS 560-C-3250 FOR STANDARD PLACEMENT AND 565-C-3250P FOR PUMP PLACEMENT PER IRWD STD. SPEC. SECTION 03300. SEE IRWD STD. SPEC. SECTION 03201 FOR CONCRETE REINFORCEMENT.
4. ANCHORS FOR TRAPEZOIDAL TRENCH SECTIONS WILL CONFORM TO TRENCH CROSS SECTION AND EXTEND A MIN. OF 12" INTO UNDISTURBED SOIL.
5. SLOPE ANCHORS SHALL NOT BE USED ON VCP.

CONCRETE SLOPE ANCHORS

IRVINE RANCH WATER DISTRICT, ENGINEERING DEPARTMENT

APPROVED BY:

KEVIN L. BURTON R.M.E. M28832
EXECUTIVE DIRECTOR, TECHNICAL SERVICES

FEBRUARY 2025
REVISION



Irvine Ranch
WATER DISTRICT

IRWD
STD. DWG.
G-10

NOT TO SCALE
SHEET 1 OF 1

TABLE OF CONTENTS

General Technical Specifications

SECTION	DESCRIPTION	DATE
01045	Existing Facilities	2/20/2024
02100	Clearing and Preparation	4/1/2010
02201	Earthwork and Grading	1/9/2019
02220	Structure Earthwork	1/9/2023
02223	Trenching, Backfilling, and Compacting	1/9/2023
02315	Jacked Casing	1/2/2021
02316	Open Trench Casing	1/2/2021
02528	Concrete Curbs, Gutters, and Sidewalks	4/1/2010
02578	Pavement Removal and Replacement	1/2/2021
02701	Installation of Gravity Sewer Pipelines	2/20/2024
02710	Vitrified Clay Pipe for Gravity Sewers	2/20/2024
02715	PVC Pipe and Fittings for Gravity Sewers	2/20/2024
03100	Concrete Formwork	12/9/2004
03201	Concrete Reinforcement	2/20/2024
03260	Concrete Joints and Waterstops	1/4/2016
03300	Concrete	2/27/2025
03345	Concrete Finishing, Curing, and Waterproofing	2/27/2025
03461	Precast Concrete Manholes and Bases	1/9/2023
03462	Precast Concrete Vaults and Meter Boxes	1/4/2022
05120	Structural Steel and Miscellaneous Metalwork	2/27/2025
09900	Painting and Coating	2/27/2025
15040	Interior Inspection for Cement-Mortar Lined Steel Pipe	1/2/2017
15041	Chlorination of Water Mains, Wells and Reservoirs	1/4/2022
15042	Hydrostatic Testing of Pressure Pipelines	1/9/2023
15043	Leakage and Infiltration Testing of Non-Pressure Pipelines	1/9/2023
15051	Installation of Pressure Pipelines	1/2/2021
15053	Carbon Steel Pipe and Fittings	1/2/2021
15056	Ductile-Iron Pipe and Fittings	1/9/2023
15057	Copper Pipe and Fittings	2/27/2025
15064	PVC Pressure Pipe and Fittings	2/20/2024
15076	Cement-Mortar Lined and Coated Steel Pipe	1/9/2023
15089	Combination Air Release and Vacuum Relief Valves	2/20/2024
15100	Manual Valves	1/9/2023
15112	Backflow Preventers	2/20/2024
15120	Hydraulically Controlled Diaphragm-Actuated Valves	1/2/2017
15139	Hydrants	2/27/2025
15150	Meters	1/4/2016

TABLE OF CONTENTS

General Technical Specifications

SECTION	DESCRIPTION	DATE
15151	Facilities Identification	2/20/2024
15162	Flexible Pipe Couplings and Expansion Joints	1/2/2021
16010	General Electrical Requirements	2/20/2024
16051	Miscellaneous Electrical Devices	2/20/2024
16110	Raceways, Pull Boxes, and Fittings	2/20/2024
16120	Conductors and Cables	2/20/2024
16135	Cabinets and Enclosures	2/20/2024
16140	Switches and Receptacles	2/20/2024
16160	Panelboards	2/20/2024
16400	Service and Distribution	2/20/2024
16450	Grounding	2/20/2024
16460	Transformers	2/20/2024
16640	Cathodic Protection and Joint Bonding	1/2/2017
16950	Electrical Testing	2/20/2024
17000	General Instrumentation Control Requirements	2/20/2024
17110	Identification Tags	1/9/2023

SECTION 01045: EXISTING FACILITIES

PART 1 - GENERAL

A. Description

This section includes requirements for connection to and abandonment of existing water and sewer facilities.

B. Related Work Specified Elsewhere

1. Trenching, Backfilling, and Compacting: 02223
2. Chlorination of Water Mains, Wells and Reservoirs: 15041
3. Hydrostatic Testing of Pressure Pipelines: 15042
4. Leakage and Infiltration Testing: 15043
5. Manual Valves: 15100

C. Location

The Contractor shall be responsible for determining in advance of constructing the improvements the location of all existing pipelines to which connections are to be made.

PART 2 - MATERIALS

All materials used in making the connection or removing the facility from service shall conform to the applicable sections of the technical specifications.

PART 3 - EXECUTION

A. Connection to Existing Waterlines

1. Notification: The Contractor shall give the District a minimum of four (4) working days notice before the time of any proposed shutdown of existing mains or services.
2. Notice to Proceed: Connections shall be made only in the presence of the District Representative. Connection work shall not proceed until the District Representative has given notice to proceed.
3. Material: The Contractor shall furnish all pipe and materials including as may be required: labor and equipment necessary to make the connections, all required excavation, backfill, pavement replacement, lights, barricades, water truck, highline hose, and fittings for making the connections. In addition, the Contractor shall assist the District in alleviating any hardship incurred during the shutdown for connections.

4. Temporary Work: Where connections are made to existing valves, the Contractor shall furnish and install all temporary blocking, steel clamps, shackles, and anchors as required by the District Representative. Valve boxes and covers shall be replaced and adjusted to the proper grade in accordance with Section 15100, Manual Valves.
5. Dewatering: The Contractor shall dewater existing mains, as required, in the presence of the District Representative.
6. Inadequate Progress: If progress is inadequate during the connection operations to complete the connection in the time specified, the District Representative shall order necessary corrective measures. All costs for corrective measures shall be paid by the Contractor.
7. Connections: Connections shall be made with as little change as possible in the grade of new pipeline. If the grade of the existing pipe is below that of the new pipeline, a sufficient length of the new line shall be deepened so as to prevent the creation of any high spot or abrupt changes in grade of the new line. Where the grade of the existing pipe is above that of the new pipeline, the new line shall be laid at specified depth, except for the first joint adjacent to the connection, which shall be deflected as necessary to meet the grade of the existing pipe. If sufficient change in direction cannot be obtained by the limited deflection of the first joint, a fitting of the proper angle shall be installed. Where the connection creates a high or low spot in the line, a standard air release or blowoff assembly shall be installed as directed by the District Representative.
8. Testing: The new pipeline shall not be connected to an existing facility until the new pipeline has successfully passed all pressure and water quality tests following disinfection in accordance with Sections 15041, Chlorination of Water Mains, Wells and Reservoirs and 15043, Leakage and Infiltration Testing.

B. Removal from Service of Existing Mains and Appurtenances

1. General Removal Requirements: Existing mains and appurtenances shall be removed from service at the locations shown on the plans or as directed by the District Representative. Removal of service for existing public domestic water and recycled water mains and appurtenances shall be defined as completely removing all facilities from the ground at all locations without the option to abandon in place unless otherwise specified. Removal of service for existing public sanitary sewer mains and appurtenances shall be defined as completely removing all facilities from the ground at all locations shallower than 8-feet below finished surface. All backfill and repair of surface shall be in accordance with Section 02223, Trenching, Backfilling, and Compacting.
2. Method of Abandonment: Existing pipe and appurtenances to be abandoned in place shall be filled with six-sack cement slurry or cellular concrete as manufactured by Cell-Crete Corporation. Where connections or stub-outs are abandoned, all valves shall be removed and the remaining flanged fitting shall be closed/plugged using a blind-flange fitting unless otherwise specified.

Where connections or stub-outs are abandoned, all valves shall be removed and the remaining flanged fitting shall be closed/plugged using a blind-flange fitting.

3. Storage of Removed Material: Removed pipe and appurtenances may be temporarily stockpiled on the job in a location that will not disrupt traffic or be a safety hazard, or it may be delivered to the District yard as directed by the District Representative.
4. Maintenance of Service: Prior to performing any work to replace existing pipes and/or services, the Contractor shall make proper provisions for the maintenance and continuation of service as directed by the District Representative.
5. Abandoned Water Services: For a water service to be considered abandoned, all surface fittings, meter, meter box and customer service valve shall be removed. The service line and corporation stop shall be removed and the service saddle plugged with a brass plug. If there is no corporation stop on the service, the adapter shall be removed and a brass plug installed in the service saddle. With special permission of the District Representative, the horizontal portions of the service line may be abandoned in place by cutting and crimping the ends closed.
6. Abandoned Sewer Laterals: Sewer laterals to be removed from service shall be cut and plugged at the main.
7. Abandoned Sewer Manholes: For sewer manholes to be abandoned, the manhole cover, ring, grade rings and manhole cone shall be removed and properly disposed. All portions of the manhole to be abandoned shall be removed to a point 8-feet below finished ground surface. The remaining portions of the manhole shall be filled with one-sack sand cement slurry or cellular concrete as manufactured by Cell-Crete Corporation.
8. Abandoned Meter Vaults, PRV Vaults and Other Structures and Boxes: For meter vaults, PRV vaults and other structures to be abandoned, the top hatch or covers, cover slab or hatch or box grade ring, grade rings and other structural elements shall be removed and properly disposed. All portions of the vault or structure to be abandoned shall be removed to a point 8-feet below finished ground surface. The remaining portions of the vault, other structure, or box shall be filled with one-sack sand cement slurry or cellular concrete as manufactured by Cell-Crete Corporation.

END OF SECTION

SECTION 02100: CLEARING AND PREPARATION

PART 1 - GENERAL

A. Description

This section includes clearing, grubbing and preparation required prior to rough grading.

B. Related Work Specified Elsewhere

1. Earthwork and Grading: 02201

C. Submittals

1. Shop drawings shall be submitted in accordance with the General Provisions and the following.
2. Submit a schedule of work and a detailed description of removal and disposal techniques.

PART 2 - MATERIALS

Not applicable.

PART 3 - EXECUTION

A. Meeting

Prior to the start of clearing and grubbing operations, a field meeting shall be held with the District Representative to discuss limits and disposal of material.

B. Limits

Clearing and preparation operations shall be confined to the limits shown on the construction plans. Only specified access roads shall be used for operation.

C. Disposal

All brush, stumps, roots, vegetation and debris shall be removed from the site and disposed of in a manner acceptable to agencies having jurisdiction over the work, the soils consultant, and the District.

D. Stockpiling

Topsoil shall be stockpiled at the location shown on the plans, or as directed by the District Representative. Stockpile shall be placed, graded, and shaped to promote proper drainage of stockpile area.

E. Permits

All permit requirements shall be complied with during the course of the work, both for transportation and disposal of materials.

END OF SECTION

SECTION 02201: EARTHWORK AND GRADING

PART 1 - GENERAL

A. Description

This section presents general procedures and requirements for grading and earthwork as shown on the approved grading plans, including preparation of areas to be filled, placement of fill, installation of subdrains, and excavations.

B. Related Work Specified Elsewhere

1. Clearing and Preparation: 02100

C. Submittals

1. Shop drawings shall be submitted in accordance with the General Provisions.
2. Material samples and grain size analyses shall be submitted for any imported fill material used.

D. Measurement and Payment

Payment for the work in this section shall be in accordance with the General Provisions and the following.

Payment for any additional cut yardage or removal/recompaction yardage shall be at the unit-price bid amount for these items. Additional cut yardage or removal/recompaction yardage may be required when field conditions dictate modifications to the original scope of the construction plans and when required by the District Representative. Measurement of additional yardage shall be made by the District Representative after consultation with the District's consultants and the Contractor.

PART 2 - MATERIALS

A. Fill Material

1. General: Material to be placed as fill shall be free of organic matter and other deleterious substances, and shall be approved by the District Representative. Expansive soils, or soils of poor gradation or strength characteristics shall either be removed from the site, and disposed of in accordance with all local regulations, placed in areas designated by the District Representative, or mixed with other soils to serve as satisfactory fill or soil material.

2. **Oversize Material:** Oversize material, defined as rock or other irreducible material with a maximum dimension greater than 12 inches, shall not be buried or placed in fills, unless the location, materials, and disposal methods are specifically approved by the District Representative. Oversize disposal operations shall be such that nesting of oversize material does not occur, and such that the oversize material is completely surrounded by compacted or densified fill. Oversize material shall not be placed within 10 feet vertically of finish grade or within the range of future utilities or underground construction, unless specifically approved by the District Representative.
3. **Imported Fill Material:** If importing of fill material is required for grading, the import material shall meet the requirements herein.

B. Subdrain Pipe

Subdrain pipe shall be ASTM D2751, SDR 23.5 or ASTM D1527, Schedule 40 Acrylonitrile Butadiene Styrene (ABS), ASTM D3034 SDR 35 or ASTM D1785, Schedule 40 Polyvinyl Chloride Plastic (PVC) pipe.

C. Filter Material

Filter material shall be Class 2 permeable material per State of California Department of Transportation Standard Specifications. Class 2 filter material shall have a sand equivalent value of not less than 75 and shall have the following gradation.

Sieve Size	Percent Passing
1"	100
3/4"	90 - 100
3/8"	40 - 100
No. 4	25 - 40
No. 8	18 - 33
No. 30	5 - 15
No. 50	0-7
No. 200	0 - 3

D. Filter Fabric Material

Unless specified otherwise, filter fabric shall be non-woven polyester material conforming to the following minimum requirements:

Property	ASTM Method	Property Value
Weight, oz. per sq. yd.	D5261	4.0
Elongation, %	D4632	50
Grab Tensile Strength, lbs.	D4632	100
Permittivity, Sec ⁻¹	D4491	20

E. Water for Compaction

Water used to assist in compaction shall conform to Section 02223, Trenching, Backfilling, and Compacting.

PART 3 - EXECUTION

A. Earthwork Observation Testing

1. Access: Adequate access shall be provided at all times to allow the District Representative to make observations and conduct tests to verify that the work complies with the requirements of the specifications. The District Representative shall be given assistance as necessary for performing test, and shall be kept apprised of work schedules.
2. Methods: Adequate equipment and methods shall be employed to accomplish the work in accordance with applicable grading codes or agency ordinances, these specifications and the approved grading plans. If, in the opinion of the District Representative, unsatisfactory conditions, such as questionable soil, poor moisture condition, inadequate compaction, and adverse weather, have resulted in a quality of work less than required in these specifications, the District may reject the work and recommend that construction be stopped until the conditions are rectified.
3. Compaction Testing: Maximum dry density test used to determine the degree of compaction will be performed in accordance with ASTM Test Method D1557.

B. Preparation of Areas to be Filled

1. Clearing and Grubbing: All brush, vegetation and debris shall be removed or piled and otherwise disposed of per Section 02100, Clearing and Preparation.
2. Processing: The existing ground, which is determined to be satisfactory for support of fill, shall be scarified to a minimum depth of 6 inches. Existing ground, which is not satisfactory, shall be overexcavated as specified in the following subsection. Scarification shall continue until the soils are broken down and free of large clay lumps or clods and until the working surface is reasonably uniform and free of uneven features which would inhibit uniform compaction.
3. Overexcavation: Soft, dry, spongy, highly fractured or otherwise unsuitable ground, extending to such a depth that surface processing cannot adequately improve the condition, shall be overexcavated down to firm ground, as directed by the District Representative.
4. Moisture Conditioning: Overexcavated and processed soils conforming to "Fill Material" specified herein shall be watered, dried-back, blended, and/or mixed, as required to attain a uniform moisture content near the optimum moisture content prior to placement and compaction.
5. Recompaction: Overexcavated and processed soils which have been properly mixed and moisture-conditioned shall be recompacted to a minimum of 90 percent of maximum dry density.
6. Benching: Where fills are to be placed on ground with slopes steeper than 5:1 (horizontal to vertical units), the ground shall be stepped or benched. The lowest bench shall be a minimum of 15 feet wide, shall be at least 2 feet deep, shall expose firm material, and shall be approved by the District Representative. Other benches shall be excavated in firm material for a minimum width of 4 feet. Ground sloping flatter than 5:1 shall be benched or otherwise over-excavated when considered necessary by the District Representative.

7. Approval: All areas to receive fill, including processed areas, removal areas and toe-of-fill benches shall be approved by the District Representative prior to fill placement.

C. Fill Placement and Compaction

1. Fill Lifts: Approved fill material shall be placed in areas prepared to receive fill in near-horizontal layers not exceeding 6 inches in compacted thickness. The District may approve thicker lifts if testing indicates the grading procedures are such that adequate compaction is being achieved with lifts of greater thickness. Each layer shall be spread evenly and shall be thoroughly mixed during spreading to attain uniformity of material and moisture in each layer.
2. Fill Moisture: Fill layers having a moisture content less than optimum shall be watered and mixed. Fill layers having a moisture content greater than optimum shall be aerated by scarification and shall be blended with drier material. Moisture-conditioning and mixing of fill layers shall continue until the fill material is plus or minus two percent of the optimum moisture content.
3. Compaction of Fill: After each layer has been evenly spread, moisture-conditioned, and mixed it shall be uniformly compacted to not less than 90 percent of maximum dry density. Compaction equipment shall be adequately sized and shall be either specifically designed for soil compaction or of proven reliability, to efficiently achieve the specified degree of compaction.
4. Fill Slopes: Fill slopes shall be overfilled and compacted, then blade cut to a firm surface. Compacting of fill slopes shall be accomplished, in addition to normal compacting procedures, by back rolling of slopes with sheepsfoot rollers at frequent increments of 2 to 3 feet in fill elevation gain, or by other methods producing satisfactory results. At the completion of grading, the relative compaction of the slope out to the slope face shall be at least 90 percent of maximum dry density.
5. Compaction Testing: Field testing to check the fill moisture and degree of compaction shall be performed by the District Representative. The location and frequency of tests shall be at the District Representative discretion. In general, the tests will be taken at an interval not exceeding 2 feet in vertical rise and/or 1,000 cubic yards of embankment. In addition, on slope faces, at least one test shall be taken for each 5,000 square feet of slope face and/or each 10 feet of vertical height of slope.

D. Subdrain Installation

Subdrains shall consist of drain pipe, compacted pipe trench backfill aggregate, and filter fabric material to prevent migration of soil fines into the subdrain system. Subdrain systems shall be installed in approved ground to conform to the size and alignment, and to the details as may be shown in the Contract Documents. The subdrain location or materials shall not be changed or modified without the approval of the District Representative. All subdrains shall be surveyed for line and grade after installation and sufficient time shall be allowed for the surveys, prior to commencement of filling over the subdrains.

E. Excavation

Excavations and cut slopes will be examined during grading. If directed by the District Representative, further excavation or overexcavation and refilling of cut areas shall be performed, and/or remedial grading of cut sloped shall be performed. Where fill-over-cut slopes are to be graded, unless otherwise approved, the cut portion of the slope shall be made and approved by the District Representative prior to placement of materials for construction of the fill portion of the slope.

F. Grading Code

All work shall be in accordance with the grading code requirements of the agencies having jurisdiction over the work. A copy of grading codes and manuals shall be retained on the job site while work is in progress.

G. Maintenance

1. Protection of Graded Areas: Newly graded areas shall be protected from traffic and erosion. Settled, eroded, and rutted graded areas shall be repaired and re-established to specified tolerances.
2. Reconditioning Compacted Areas: Where completed compacted areas are disturbed by subsequent construction operations or adverse weather, these areas shall be scarified, re-shaped, and compacted to required density prior to further construction.
3. Settling: Where settling is measurable or observable at excavated areas during the project or warranty period, the surface (pavement, lawn or other finish), shall be removed, backfill material added and compacted, and surface treatment replaced. The appearance, quality, and condition of surface or finish shall be restored to match adjacent work.

END OF SECTION

SECTION 02220: STRUCTURE EARTHWORK

PART 1 - GENERAL

A. Description

This section describes excavation, backfilling, materials, testing, and shoring for underground structures including control valve vaults, wet wells, dry well vaults, meter vaults, valve vaults, and pump vaults.

B. Related Work Specified Elsewhere

1. Trenching, Backfilling, and Compacting: 02223
2. Pavement Removal and Replacement: 02578
3. Concrete Formwork: 03100

C. Submittals

1. Shop drawings shall be submitted in accordance with the General Provisions and the following.
2. Submit drawings of excavation and shoring, sheeting or bracing for worker protection in accordance with the General Provisions.
3. Submit six copies of a report from a testing laboratory verifying that gravel base and structural backfill conforms to the specified gradations or characteristics.
4. Test reports on borrow material.
5. Other tests and material reports as required.

D. Protection of Existing Utilities and Facilities

1. General: The Contractor shall be responsible for the care and protection of all existing sewer pipelines, water pipelines, gas mains, storm drains, culverts, or other facilities and structures that may be encountered in or near the area of work.
2. Notification: It shall be the duty of the Contractor to notify each agency of jurisdiction and make arrangements for locating each agency's facilities prior to beginning construction.
3. Damage: In the event of damage to any existing facilities during the progress of the work due to the failure of the Contractor to exercise the proper precautions, the Contractor shall be responsible for the cost of all repairs and protection to said facilities. The Contractor's work may be stopped until repair operations are complete.

E. Protection of Landscaping

The Contractor shall be responsible for the protection of all the trees, shrubs, fences, and other landscape items adjacent to or within the work area, unless directed otherwise on the plans. In the event of damage to landscape items, the Contractor shall replace the damaged items in a manner satisfactory to the District Representative.

PART 2 - MATERIALS

A. Definition of Zones

1. Pavement and Street Zones: Pavement and street zones shall be as defined in Section 02223, Trenching, Backfilling, and Compacting.
2. Upper Backfill Zone: The upper backfill zone is defined as the backfill to the full width of the excavation from the top of the structure to the bottom of the street zone in paved areas or to the finished surface in unpaved areas.
3. Structural Backfill Zone: The structural backfill zone is defined as backfill from the top of the structure to the bottom of the excavation, extending the full width of the excavation.

B. Native Earth Backfill - Upper Backfill Zone

Native earth backfill shall be excavated fine-grained non-organic materials free from peat, roots, debris, and rocks larger than 3 inches, and which can be compacted to the specified relative compaction.

C. Structural Backfill - Structural Backfill Zone

Structural backfill materials shall consist of hard, durable, and clean sand, gravel, or crushed stone which is free of organic material, clay balls, and other deleterious substances, and shall have the following gradation:

<u>Sieve Size</u>	<u>Percent Passing by Weight</u>
2 inches	100
1-½ inches.....	95 to 100
¾ inch.....	50 to 100
⅜ inch.....	15 to 55
No. 4.....	0 to 25
No. 8.....	0 to 5
No. 200.....	0 to 3

D. Crushed Rock Base

Crushed or natural rock with the following gradation shall be provided as base under the structure.

<u>Sieve Size</u>	<u>Percent Passing by Weight</u>
3 inches	100
1-½ inches.....	0 to 100
¾ inch.....	60 to 100
No. 4.....	25 to 55
No. 30.....	10 to 30
No. 200.....	0 to 5

E. Water for Compaction

Water used to assist in compaction shall conform to Section 02223, Trenching, Backfilling, and Compacting.

PART 3 - EXECUTION

A. Testing for Compaction

Testing for compaction shall conform to Section 02223, Trenching, Backfilling, and Compacting.

B. Compaction Requirements

1. Backfill in Street Zone: 95% relative compaction.
2. Upper Backfill Zone: 90% relative compaction.
3. Structural Backfill Zone: 90% relative compaction.
4. Crushed Rock Base: 80% relative density.

C. Dewatering

1. General: Dewatering operations shall continuously remove and dispose of all water entering the excavation during construction of the structure and all backfill operations. Water shall be disposed of in a manner to prevent damage to adjacent property and pipe trenches in conformance with all local regulations. Water shall not be allowed to rise in the excavation until backfilling around and above the structure is completed.
2. Notification: The District shall be notified 48 hours prior to commencement of dewatering operations. Methods employed shall be in conformance with the District's existing NPDES permit. A copy of the NPDES permit is generally included in the appendix of the Project Manual with the project specifications.

D. Structure Excavation

1. Removal of Material: Structure excavation shall include the removal of all material necessary for the construction of underground structures and foundations.
2. Clearance: Unless noted otherwise on the plans, the sides of excavations for structures shall be sufficient to leave at least a 2-foot clearance, as measured from the extreme outside of formwork or the structure. Excavation side slopes shall be as specified in Subsection E.
3. Overdepth Excavations: Overdepth excavations shall be corrected by backfilling with crushed rock or concrete, as directed by the District Representative. No native earth backfill will be permitted to correct overdepth excavation beneath structures.
4. Surplus Material: Surplus material shall be disposed of in accordance with Section 02223, Trenching, Backfilling, and Compacting.

E. Support for Excavations for Structures

1. Safety: A safe working area shall be provided for workers. The services of a Registered Civil Engineer shall be obtained to design sheeting, shoring and bracing, or side slopes. The requirements of CAL/OSHA and of these specifications shall be used as minimum design criteria. Sufficient geotechnical data shall be obtained to provide safe design.
2. Side Slopes: Minimum side slope shall be per CAL/OSHA but not steeper than:
 - a. Clayey soil up to 12-foot depth: 3/4 horizontal to 1 vertical (3/4:1).
 - b. Clayey soil more than 12-foot depth: vary from 3/4:1 for 12-foot depth to 3:1 for 20-foot depth.
 - c. Gravelly soil: 2 horizontal to 1 vertical (2:1).
 - d. Flatten above slopes if groundwater is present.
3. Traffic Safety: Methods of support or side slopes shall be selected to provide sufficient clearance for public traffic safety and convenience.
4. Design Loads: The characteristics of the soil exposed in the excavation, the groundwater conditions, traffic, and other surcharge loads shall be considered when selecting lateral pressures to be used for design of soil supporting systems.

5. Design Criteria: The following minimum design criteria for allowable lateral passive soil pressure expressed in pounds per square foot (psf) shall be used to calculate depth of penetration of isolated soldier piles or solid sheet piles. Where needed for safety, these values shall be increased.

	<u>Predominant Soil Type</u>	
	<u>Clayey</u>	<u>Granular</u>
Isolated Soldier Piles	200 Z + 1,870	467 Z
Solid Sheet Piles	67 Z + 633	300 Z

Where Z = depth in feet below bottom of excavation.

6. Verification of Soil Types: Prior to design and submittal of support system, verification of the type of soil below the bottom of the excavation shall be made.

F. Backfill Against Walls and Over Roof Slabs

1. Precautions

- a. Backfill over structure shall be placed in a manner so as to not damage the roof membrane and protective cover.
- b. Backfill shall not be placed against walls or above buried roof slabs until the concrete has obtained a comprehensive strength equal to the specified 28-day compressive strength. Where backfill is to be placed on both sides of the wall, the backfill shall be placed uniformly on both sides. Where backfill is to be placed around a structure, the backfill shall be placed at a uniform rate around the structure.
- c. Backfill shall not be placed against the walls of structures that are laterally restrained or supported by suspended slabs or slabs on grade until the slab is poured and the concrete has reached the specified compressive strength.
- d. When backfill is to be placed before 7-day concrete strength tests have been conducted on concrete arches for VCP sewers or thrust blocks, the concrete shall have achieved 50 percent of the specified minimum 28-day strength. An additional test cylinder shall be made for this test.

2. Equipment: Equipment for placing and compacting backfill over structures shall not exceed 15 tons total weight and a maximum wheel load of 10,000 pounds. Equipment weighing more than 10,000 pounds shall not be used closer to walls and structures than a horizontal distance equal to the depth of fill at the time.

G. Compaction

1. Compaction for Zones: Compaction shall be controlled to the percentage of density specified for each zone.

2. Moisture Control: Moisture shall be controlled as follows:
 - a. Where subgrade or soil material layers must be moisture conditioned before compaction, water shall be uniformly applied to the subgrade surface or soil layer material in order to prevent free water from appearing on the surface during or subsequent to compaction operations. The moisture content of the compacted soil shall be within 3 percentage points of the optimum.
 - b. Soil material that is too wet to permit compaction to specified density shall be removed and replaced or scarified and air dried.
 - c. Soil material that has been removed because it is too wet to permit compaction may be stockpiled or spread within an approved area and allowed to dry. Drying may be assisted by discing, harrowing or pulverizing, until moisture content is reduced to satisfactory value.
 - d. Backfill or fill material shall not be placed on surfaces that are muddy, frozen, or contain frost or ice.
3. Requirements Prior to Backfilling: Excavations shall be backfilled as work permits, but not until completion of the following:
 - a. Acceptance of construction below finish grade including, where applicable, dampproofing, waterproofing, and perimeter insulation.
 - b. Inspection, testing, approval, and recording locations of underground utilities.
 - c. Removal of concrete formwork per Section 03100, Concrete Formwork.
 - d. Removal of shoring and bracing, and backfilling of voids with satisfactory materials. Cut off temporary sheet piling driven below bottom of structures and remove in manner to prevent settlement of the structure or utilities, or leave in place, if required.
 - e. Removal of trash and debris.
 - f. Permanent or temporary horizontal bracing is in place on horizontally supported walls.
4. Backfill Layers: Backfill and fill materials shall be placed in layers not more than 8 inches in loose depth for material compacted by heavy compaction equipment, and not more than 4 inches in loose depth for material compacted by hand-operated tampers.
5. Jetting: Unless specified otherwise, jetting techniques shall not be employed to densify granular fill materials.
6. Uniform Backfill Lifts: Backfill and fill materials shall be placed evenly adjacent to structures, to required finish elevations. Care shall be taken to prevent wedging action of backfill against structures by carrying material uniformly around structure to approximately same elevation in each lift.

END OF SECTION

SECTION 02223: TRENCHING, BACKFILLING, AND COMPACTING

PART 1 - GENERAL

A. Description

This section describes materials, testing, and performance of trench excavation, backfilling and compacting.

B. Related Work Specified Elsewhere

1. Pavement Removal and Replacement: 02578
2. Concrete: 03300
3. Hydrostatic Testing of Pressure Pipelines: 15042
4. Cathodic Protection and Joint Bonding: 16640

C. Submittals

1. Shop drawings shall be submitted showing excavation and shoring, bracing, or sloping for worker protection in accordance with the General Provisions, and the following:
2. Six copies of a report from a testing laboratory shall be submitted verifying that backfill material conforms to the specified gradations or characteristics for pea gravel, granular material, imported sand, rock refill for foundation stabilization, and water.

D. Measurement and Payment

1. Payment for the work in this section shall be in accordance with the General Provisions and the following:
 - a. Foundation Stabilization

Payment for foundation stabilization shall be made in accordance with the unit-price bid amount for any quantity of refill material from 0 to 1,000 cubic yards, based on the trench details shown on the plans. These items have been included in the bid form for work that may possibly be required to complete the project, but which cannot be reasonably predicted, and shall be the basis of payment for refill material for foundation stabilization if authorized in writing by the District. The unit price shall be for any quantity installed, complete in place, including all additional earthwork, disposal of all excess or waste material, and placing of the refill material. The District Representative shall be the sole judge as to the necessity, the amount, and depth that may be required in any given situation. No additional payment shall be made for foundation stabilization that is not authorized by the District.

b. Drying / Blending / Transporting

All costs of drying, blending, transporting, and/or importing backfill material and all costs for the removal and disposal of unsuitable material and excess excavated material shall be included in the prices bid for the various items of work.

c. Protection of Existing Utilities / Services & Potholing

Full compensation for protection of utilities or replacement of utilities and street improvements including, but not limited to removal and disposal and reconstruction of existing curb, gutter, spandrels, cross-gutters, sidewalks, driveway aprons, and handicapped ramps shall be included in the contract unit prices for which such work is appurtenant thereto, and no additional allowance or payment will be made therefore. Said various contract unit prices shall include all labor, materials, tools, and equipment necessary or incidental to the replacement work. The same shall apply to all costs incurred in exposing or excavating existing utilities and service lines, and no additional allowance will be made therefore, as they shall be included in the prices bid for the various items of work.

E. Protection of Existing Utilities and Facilities

1. **General:** The Contractor shall be responsible for the care and protection of all existing sewer pipelines, water pipelines, gas mains, storm drains, culverts, or other facilities and structures that may be encountered in or near the area of work. Unless otherwise indicated on the plans or specifications, all utilities shall be protected in place and service shall be continuously maintained.

The Contractor shall be responsible for the location of and protect in place, all service connections whether or not shown on the plans. Utilities crossing the proposed pipeline alignment (where shown in "plan" and "profile" view) on the plans are plotted from the information obtained from the respective utility's owner or from available pot-hole information. In accordance with Section 8 of the General Provisions, the accuracy of the utilities is not guaranteed. Actual locations (not depth) will be provided by utilities through the Underground Service Alert (USA) process.

It shall be the contractor's responsibility to make exploratory excavations (by "hand" where prudent) to determine the true location and depth of all utilities shown on the plans. The contractor shall also determine the type of material and condition of any utility which may be affected by or affect the work. The contractor shall conduct exploratory excavations at least 1,500 feet ahead of a pipe trench heading (a minimum of five (5) days in advance of the planned construction) to provide sufficient lead-time to resolve utility conflicts.

2. **Notification:** It shall be the duty of the Contractor to notify each agency of jurisdiction and make arrangements for locating each agency's facilities prior to beginning construction.
3. **Damage:** In the event of damage to any existing facilities during the progress of the work due to the failure of the Contractor to exercise the proper precautions, the Contractor shall be responsible for the cost of all repairs and protection to said

facilities. The Contractor's work may be stopped until repair operations are completed to the satisfaction of the District.

F. Protection of Landscaping

1. **General:** The Contractor shall be responsible for the protection of all the trees, shrubs, fences, and other landscape items adjacent to or within the work area, unless directed otherwise on the plans. In the event of damage to landscape items, the Contractor shall replace the damaged items in a manner satisfactory to the District Representative.
2. **Restoration:** After the completion of work in planted or improved areas within public or private easements, the Contractor shall restore such areas to the original condition. Restoration shall include regrading, placement of 5 inches of topsoil, reseeding, and replacement of landscaping.

G. Definition of Zones

1. **Pavement Zone:** The pavement zone shall include the asphaltic concrete and aggregate base pavement section placed over the street zone. This zone is often referred to as the "structural section" of the street or highway.
2. **Trench Zone:** The trench zone shall include the portion of the trench from the top of the pipe zone to the bottom of the pavement zone in paved areas or to the existing surface in unpaved areas.
3. **Pipe Zone:** The pipe zone shall include the full width of trench from the bottom of the pipe or conduit to a horizontal level 12 inches above the top of the pipe. Where multiple pipes or conduits are placed in the same trench, the pipe zone shall extend from the bottom of the lowest pipes to a horizontal level above the top of the highest or topmost pipe. This zone is also part of the "pipe bedding zone" and as such it shall be filled with bedding material identical to that which is placed in the pipe base.
4. **Pipe Base:** The pipe base shall be defined as a layer of material immediately below the pipe zone and extending over the full trench width. This is also part of the "pipe bedding zone".
5. **Pipe Bedding Zone:** The pipe bedding zone shall include the zones defined as the "pipe base" and the "pipe zone". It shall include the full width of the trench from the bottom of the trench to a point 12 inches above the top of the pipe. Unless specified otherwise the pipe bedding zone shall be from 6 inches under the pipe to 12 inches over it.

H. Testing for Compaction

1. **Methods:** The density of soil shall be determined in place by the sand cone method, ASTM D 1556, or by the nuclear method, ASTM D 2922 or D 3017.
2. **Soil Moisture-Density Relationship:** The laboratory moisture-density relations of soils shall be determined per ASTM D 1557.
3. **Cohesionless Materials:** The relative density of cohesionless materials shall be determined by ASTM D 4253 and D 4254.

4. Sampling: Backfill materials shall be sampled per ASTM D 75.
5. Relative Compaction: "Relative compaction" shall be expressed as the ratio, expressed as a percentage, of the in place dry density to the laboratory maximum dry density.
6. Compaction Compliance: Compaction shall be deemed to comply with the specifications when none of the tests falls below the specified relative compaction. When tests are conducted by the District, the Contractor shall notify the District 24 hours in advance of when backfill lifts are ready for testing, and shall pay the costs of any retesting of work not conforming to the specifications.
7. Testing Intervals: Unless noted otherwise, compaction tests shall be performed at random depths and at 200-foot intervals, and as directed by the District Representative.

The presence of marginal materials, poor soil conditions or a prevalence of failed test results will be cause for substantially increasing the frequency and intervals of required testing. Alternatively, with approval of the District Representative, the trench zone may be backfilled with a 2-sack sand-cement slurry at no additional cost to the District.

PART 2 - MATERIALS

A. Pavement Zone Materials

Pavement zone materials shall be as specified in Section 02578, Pavement Removal and Replacement.

B. Native or Imported Backfill for Trench Zone

Trench backfill shall be onsite soils generated from trench excavation or approved imported soil. Trench backfill shall be non-organic materials free from peat, roots, debris, and rocks larger than 3 inches, and which can be compacted to the specified relative compaction. Additionally, the suitability of the backfill materials shall comply with the approved plan, Special Provisions, or requirement by the geotechnical consultant if applicable.

C. Backfill Material for Pipe Bedding Zone

1. Ductile iron pipe, welded steel pipe, PVC pressure pipe, and copper pipe: Unless otherwise specified or shown on the plans, the pipe base and pipe zone (a.k.a., pipe bedding zone) backfill material shall be imported sand of a gradation and composition as specified herein.
2. Vitrified clay pipe and PVC gravity pipe: Unless otherwise specified or shown on the plans, pipe base and pipe zone backfill shall be 3/4-inch crushed aggregate base rock (or by special permission from the District) crushed miscellaneous of a gradation and composition as specified herein.

D. Imported Sand--Pipe Zone and Pipe Base

Imported sand used in the pipe bedding zone (pipe zone and pipe base) shall conform to the California Standard Specifications for Public Works Construction, Section 200-1.5.1 and shall meet the following gradation:

Sieve Size	Percent Passing by Weight
3/8 - inch	100
No. 4	75 – 100
No. 30	12 – 50
No. 100	5 – 20
No. 200	0 – 11

Minimum sand equivalent shall be 30 for natural imported material and shall be 40 for screened recycled materials per ASTM D 2419.

E. Crushed Rock--Pipe Zone and Pipe Base

Crushed rock shall be crushed aggregate base material and shall conform to the California Standard Specifications for Public Works Construction, Section 200-1.2 and shall meet the following gradation:

Designated Material Size Percent Passing by Weight				
Sieve Sizes	1-1/2-inch	1-inch	3/4-inch	3/8-inch
2-inches	100	---	---	---
1-1/2-inches	90 - 100	100	---	---
1-inch	20 - 55	90 - 100	100	---
3/4-inch	0 – 15	30 – 60	90 – 100	---
1/2-inch	---	0 – 20	30 – 60	100
3/8-inch	0 – 5	---	0 – 20	90 - 100
No. 4	---	0 - 5	0 – 5	30 - 60
No. 8	---	---	---	0 - 10

Crushed aggregate base materials used for pipe bedding shall be 3/4 - inch unless otherwise called for by the project plans and specifications or as directed by the District Representative.

Crushed miscellaneous base materials may be substituted for crushed aggregate base materials by special permission from the District. In such cases, materials shall conform to the requirements of the California Standard Specifications for Public Works Construction, Section 200-2.4, except that gradation of the materials shall still comply with the percentages by weight on the table above.

F. Re-fill Material for Foundation Stabilization

Refill material below the pipe shall be either material conforming to the 1-1/2 - inch size requirement for gravel or crushed rock, or naturally occurring rock having the following gradation:

Sieve Size	Percent Passing by Weight
3-inches	100
1-1/2-inches	70 – 100
3/4-inch	60 – 100
No. 4	5 – 55
No. 30	0 – 30
No. 200	0 – 10

G. Sand-Cement Slurry Refill Material for Foundation Stabilization in Pipe Base & Pipe Zone

Sand-Cement slurry shall consist of one sack (94 pounds) of portland cement per cubic yard of sand and sufficient moisture for workability.

H. Water for Compaction

Water used in compaction shall be recycled water, unless otherwise approved, and have a maximum chloride concentration of 500 mg/l, a maximum sulfate concentration of 500 mg/l, and shall have a pH of 6.0 to 9.0. Water shall be free of acid, alkali, or organic materials injurious to the pipe coatings or the environment.

PART 3 - EXECUTION

A. Compaction Requirements

Unless otherwise shown on the drawings or otherwise described in the specifications for the particular type of pipe installed, relative compaction in pipe trenches shall be as follows:

- 1. Material Testing:** The suitability of all imported or native materials shall be tested before the start of compaction operations to determine the soil moisture-density relationship. Variations in imported or native earth materials may require a number of base curves of the soil moisture-density relationship.
- 2. Trench Zone:** Backfill in trench zone greater than 18 inches below the pavement zone shall be compacted to not less than 90% relative compaction. Backfill less than or equal to 18 inches below the pavement zone shall be compacted to not less than 95% relative compaction.
- 3. Pipe Bedding Zone (Pipe Base and Pipe Zone):** Materials placed as pipe bedding material in the pipe base and pipe zone shall be consolidated to 90% relative optimum compaction. Note that 95% relative optimum compaction shall be required in specific areas shown on the plans and profile drawings. From time to time this higher density will be deemed necessary by the District Representative or the local jurisdiction.

4. Foundation Stabilization: Rock refill material for foundation stabilization, where required shall be placed and consolidated to 90% relative optimum density.
5. Over-excavation: Rock refill for over-excavation shall be placed and consolidated to 90% relative optimum density.

B. Material Replacement

Trenching and backfilling material, which does not meet the specifications, shall be removed and replaced at no additional expense to the District.

C. Sheeting, Shoring, and Bracing of Trenches

Trenches shall have sheeting, shoring, and bracing conforming to CAL/OSHA requirements and General Provisions. Lateral pressures for design of trench sheeting, shoring, and bracing shall be based on type of soil exposed in the trench, groundwater conditions, surcharge loads adjacent to the trench, and type of shoring that will be used in the trench.

D. Sidewalk, Pavement, and Curb Removal

Bituminous and concrete pavements (regardless of the thickness), curbs, and sidewalks shall be cut prior to excavation of the trenches in accordance with Section 02578, Pavement Removal and Replacement. Pavement and concrete materials shall be removed from the site and shall not be used for trench backfill.

E. Trench Widths

1. Trench Width Limits: Unless shown otherwise on the drawings, trench widths in the pipe zone shall be as shown on Standard Drawing Nos. W-17 or S-6. Trench width at the top of the trench shall not be limited except where width of excavation would undercut adjacent structures and footings. In such cases, width of trench shall be such that there is at least 18 inches between the top edge of the trench and the structure or footing.

Excavation and trenching shall be true to line so that a clear space is provided in the pipe zone on each side of the largest outside diameter of the pipe. The largest outside diameter shall be the outside diameter of the bell on bell and spigot pipe.

2. Over-width Trench: Where the trench width in the pipe zone, is wider than the maximum set forth above, the trench area around the pipe shall be backfilled in accordance with the directive of the Engineer and at the discretion of the District Representative.

F. Grade

Trenches shall be excavated to the lines and grades shown on the drawings with allowance for the thickness of the pipe and for pipe base. If the trench is excavated below the required grade, the portion of the trench excavated below the grade shall be refilled with refill material at no additional cost to the District. Refill material shall be placed over the full width of trench in compacted layers not exceeding 6 inches deep to the required grade with allowance for the pipe base. Hard spots that would prevent a uniform thickness of pipe base shall be removed. Before laying pipe sections, the grade

shall be checked and any irregularities corrected. The trench bottom shall form a continuous and uniform bearing and support for the pipe at every point.

G. Pipe Base Thickness

Thickness of the pipe base shall be as shown on the drawings or as otherwise described in the specifications for the particular type of pipe installed, but in no cases shall the thickness be less than 6 inches.

H. Dewatering

1. Means and Devices: Suitable means and devices shall be provided and maintained to continuously remove and dispose of all water entering the trench excavation during the time the trench is being prepared for the pipe laying, during the laying of the pipe, and until the backfill at the pipe zone has been completed. Water shall be disposed of in a manner to prevent damage to adjacent property. Trench water shall not be drained through the pipeline under construction. Groundwater shall not be allowed to rise around the pipe until jointing compound has firmly set.
2. Notification: The District shall be notified 48 hours prior to commencement of dewatering. Methods employed shall be in conformance with the District's existing NPDES permit. A copy of the permit is included in the Appendix of the Project Manual.

I. Storage of Excavated Material

During trench excavation, excavated material shall be stored only within the working area. Roadways or streets shall not be obstructed. The safe loading of trenches with excavated material shall conform to federal, state, and local codes.

J. Length of Open Trench

The length of open trench shall be limited to 600 feet in advance of pipe laying or amount of pipe installed in one working day. Backfilling and temporary or first layer paving shall be completed so that not more than 500 feet of trench is open in the rear of pipe laying. Sidewalks, driveways and other traveled ways shall be backfilled or adequately bridged to provide safe access and egress at the completion of each day's work.

K. Foundation Stabilization

After the required excavation has been completed, the District Representative shall inspect the exposed trench subgrade to determine the need for any additional excavation. It is the intent that additional excavation shall be conducted in all areas within the influence of the pipeline where unacceptable materials exist at the exposed subgrade. Overexcavation shall include the removal of all such unacceptable material that exists directly beneath the pipe base and to the depth required. The presence of unacceptable material may require excavating a wider trench. The width and depth of known areas to be overexcavated shall be shown on the drawings. The overexcavated portion of the trench shall be backfilled to the subgrade of the pipe base with refill material for foundation stabilization. Foundation stabilization material shall be placed over the full width of the excavation and compacted in layers not exceeding 6 inches in depth, to the required grade.

L. Trench Backfilling and Compaction

1. General: Trench backfill shall conform to requirements of the detailed piping specification for the particular type of pipe and following.
2. Pipe Base: The specified thickness of pipe base material shall be placed over the full width of trench. The top of the pipe base shall be graded ahead of the pipe laying to provide firm, uniform support along the full length of pipe.
3. Bell Holes: Bell holes shall be excavated at each joint to permit proper assembly and inspection of the entire joint.
4. Pipe Zone: After the pipe has been bedded, pipe zone material shall be placed simultaneously on both sides of the pipe, keeping the level of backfill the same on each side. Material shall be carefully placed around the pipe so that the pipe barrel is completely supported and that no voids or uncompacted areas are left beneath the pipe. Particular care shall be taken in placing material on the underside of the pipe to prevent lateral movement during subsequent backfilling. Material placed within the pipe zone shall be compacted by hand tamping only.
5. Trench Zone: Backfill material shall be carefully deposited onto the backfill previously placed in the pipe zone. Free fall of the material shall not be permitted until at least 2 feet of cover is provided over the top of the pipe. Sharp, heavy pieces of material shall not be dropped directly onto the pipe or the tamped material around the pipe.
6. Trench Backfill: Trench backfill shall be compacted to the specified relative compaction. Compaction shall be performed by using mechanical compaction or hand tamping equipment. Unless specified otherwise, consolidation by jetting or flooding shall not be permitted. High impact hammer-type equipment shall not be used except where the pipe manufacturer warrants in writing that such use will not damage the pipe.
7. Equipment: Axle-driven or tractor-drawn compaction equipment shall not be used within 5 feet of walls and structures.
8. Street Zone Backfill: Street zone backfill shall be done in accordance with the requirements and to the satisfaction of the County or City agency having jurisdiction.

M. Compacted Embankment

Earthwork for construction of compacted embankment shall be as specified in Section 02201, Earthwork and Grading.

N. Import or Export of Backfill Material

1. Excess Material: Excess excavated soil material shall be removed and disposed of off the project site at no additional expense to the District. Excess soil material shall be disposed of in accordance with local regulations.
2. Imported Material: Any additional backfill material necessary to return all grades to plus or minus 0.2 feet from the grade encountered at the beginning of

construction or as shown on the contract drawings shall be imported, placed, and compacted at no additional expense to the District.

O. Moisture Content of Backfill Material

During the compacting operations, optimum practicable moisture content required for compaction purposes shall be maintained in each lift of the backfill material. Moisture content throughout the lift shall be maintained at a uniform level. If placement is discontinued and proper moisture content not maintained, the upper layer shall be brought back to proper moisture content by sprinkling, cultivating and rolling the backfill material before placing new material. At the time of compaction, the water content of the material shall be at optimum water content plus or minus two percentage points. Material which contains excessive moisture shall not be worked to obtain the required compaction. Material having excessive moisture content may be dried by blading, discing, or harrowing to hasten the drying process.

END OF SECTION

SECTION 02315: JACKED CASING

PART 1 - GENERAL

A. Description

This section describes tunneling using jacked steel casing for highway, culvert, utility and structure crossings and other shallow depth tunnels less than 500 feet in length. This section also describes carrier pipe installation within the steel casing. Open trench casing installations shall be installed in accordance with Section 02316, Open Trench Casing.

B. Related Work Specified Elsewhere

1. Trenching, Backfilling, and Compacting: 02223
2. Open Trench Casing: 02316
3. Concrete: 03300
4. Hydrostatic Testing of Pressure Pipelines: 15042
5. Leakage and Infiltration Testing: 15043
6. Installation of Pressure Pipelines: 15051

C. Submittals

1. Shop drawings shall be submitted in accordance with the General Provisions and as specified herein.
2. Submit manufacturer's mill specification sheet listing diameter, thickness, and class of steel used in making the casing, and the mill certification.
3. Submit drawings showing the location of approach trench, jacking pit, tunnel and receiving pit, and joint type for both casing and carrier pipe. Include the details of all grout couplings and other attachments and appurtenances to the casing.
4. Submit a tunnel construction schedule which includes casing installation, carrier pipe installation, approach trench backfill, and receiving pit backfill.
5. Submit an engineered shoring plan for the bore-pit and receiving-pit. Shoring submittals shall be wet-signed and stamped by a California-licensed Civil or Structural Engineer.

D. Permits

All work shall conform to the specifications and requirements of the State of California Department of Transportation, the Orange County Planning & Development Services Department, the City, or the railroad company involved. The Contractor shall secure all required permits for construction of casing pipe installation.

E. Scheduling

If the pipeline is not installed within the casing as a continuous operation following completion of the jacking of the casing, the casing portals shall be bulkheaded and the approach trenches backfilled and later reopened for pipe installation.

F. Line and Grade

Contractor shall continuously survey jacked casing for conformance with design line and grade. Survey data shall be taken at a maximum of 40-foot intervals.

PART 2 - MATERIALS

A. Steel Casing

1. Materials: Steel casing shall be ASTM A283, Grade C, ASTM A570 Grade 30, 33, and ASTM A36 unless noted otherwise. Unless shown on the drawings, the minimum inside diameter and wall thickness of the casing shall be as described herein. Greater casing thickness and diameter may be used as convenient for the method of work and loadings involved, as suitable for the site and as limited by possible interferences, but at no additional cost to District.

The Contractor shall choose a size of casing at or above the minimum specified, in order that the jacking may be done with a sufficient degree of accuracy to permit installation of the carrier pipe to the grades shown on the plans and to properly accommodate the largest dimension of the carrier pipe.

2. Joints & Welding: Casing sections shall be joined by full circumference welding. Field welds shall be full-penetration bevel welds in accordance with the standards of quality as set forth in the specifications of the American Welding Society. All welding shall be performed by skilled welders qualified under the provisions of ANSI/AWS D1.1. Welder qualifications shall be certified by an independent local, approved testing agency not more than 6 months prior to commencing work. Prepare ends of casings for proper bevel weld by providing a 45-degree bevel on the end of one of the two casing pieces being joined.
3. Wall Thickness: Minimum size and thickness of casing pipes for insertion of various sizes of carrier pipes shall be as shown in the IRWD Standard Drawings unless a larger or heavier wall casing pipe is required by the agency having jurisdiction over the road or railroad crossing or the contractor requests use of a thicker wall pipe.

B. Casing Seals

1. When the casing is not filled with cellular concrete, the casing seals shall be 1/8-inch thick synthetic, rubber, designed to fit snugly around pipe and casing. Casing seals may be one piece with no field seams or the wrap-around style to facilitate installation after the casing and carrier pipe are already installed. Seamless style is preferred. Bands and hardware for attachment to pipe and casing OD shall be stainless steel.

2. When the casing is filled with cellular concrete, the casing seals shall be of brick and mortar.

C. Pipe Skids and Blocking

1. Skids and blocking shall be manufactured stainless steel casing spacers with composite runner skids.
2. Casing spacer skids and blocking shall be bolt-on style with a shell made of at least two halves. The band material shall be manufactured of a minimum 14 gauge T-304 stainless steel and 10 gauge T-304 stainless steel risers when needed. All welds are to be chemically passivated. The runners shall be at least 11 inches long and shall be manufactured of high abrasion resistant and low coefficient of friction, glass filled polymer. Fasteners and hardware for securing the spacers and runners shall be stainless steel. Casing spacers shall have a flexible EPDM liner having a minimum thickness of 0.090 inches with a hardness of Durometer "A" 85-90. The liner shall have a rating of no less than 60,000 VPM and water absorption of 1% maximum.
3. Manufacturers: Casing spacers shall be as manufactured by Advance Products & Systems, Inc., Cascade Waterworks Mfg. Co., CCI Pipeline Systems, or Pipeline Seal & Insulator, Inc.

D. Grout

1. Exterior of Casing: Grout shall consist of an 8 sack sand slurry.
2. Interior of Casing (between carrier pipe and casing): Grout shall consist of cellular concrete as manufactured by Cell-Crete Corporation. The cellular concrete shall have minimum compressive strength of 100 psi.

E. Grout Connections

The contractor shall provide threaded steel half-couplings on the inside of the casing pipe at the locations, spacing and orientation called for in the IRWD Standard Drawings. Spacing of the grout connections may be decreased to provide more frequent grouting, but in no case shall the spacings shown on the drawings be exceeded.

PART 3 - EXECUTION

A. Safety

For contracts between the Contractor and an entity other than the District, the Contractor shall obtain from the Division of Industrial Safety a classification for each bore exceeding 30-inches in diameter. For contracts between the Contractor and the District, the District has obtained from the Division of Industrial Safety a classification for each bore where required. The boring and jacking work shall be done in conformance with the State of California's requirements. It shall be the Contractor's responsibility to call the required safety meeting with representatives from the State Division of Industrial Safety prior to beginning of construction of each bore.

B. Jacking Pit

1. Excavation Protection: The approach trench for jacking or boring operations shall be adequately shored to safeguard existing substructures and surface improvements and to ensure against ground movement in the vicinity of the casing portal.
2. Structural Support for Jacking Equipment: Heavy guide timbers, structural steel, or concrete cradle of sufficient length shall be placed in the approach trench of the jacking pit and firmly bedded on the required line and grade to provide accurate control of jacking alignment. Adequate space shall be provided to permit the insertion of the lengths of casing to be jacked. The structure of timbers and structural steel sections shall be anchored to ensure action of the jacks in line with the axis of the casing. A bearing block consisting of a timber or structural steel framework shall be inserted between the jacks and the end of the casing to provide uniform end bearing over the perimeter of the casing and distribute the jacking pressure evenly.

C. Sectional Shield or Jacking Head

1. Equipment: A sectional shield or steel jacking head shall be attached to the leading section of the casing to extend around the outer surface of the upper two-thirds of the casing and to project at least 18 inches beyond the driving end of the casing. The sectional shield or jacking head shall not protrude more than 1/2-inch outside of the outer casing surface. The head shall be anchored to prevent any wobble or alignment variation during the jacking operation.
2. Removal of Excavated Material: To avoid loss of ground outside the casing, excavation shall be restricted to the least clearance necessary to prevent binding, and shall be carried out entirely within the jacking head and not in advance of the head. Excavated material shall be removed from the casing as jacking progresses and no accumulation of excavated material within the casing will be permitted.

D. Control of Alignment and Grade

Application of jacking pressure and excavation of material ahead of the casing as it advances shall be controlled to prevent the casing from becoming earthbound or deviating from the required line and grade shown on the Plans. Allowable grade deviations in horizontal and vertical alignments shall be no greater than 0.2 feet per 100 feet in any direction over the length of the jacking and boring operation. A maximum cumulative deviation shall not exceed 0.5 feet overall. Do not encroach upon the minimum annular space detailed. The District will check line and grade at intervals not exceeding 40-feet to ensure compliance with plans.

E. Grouting

1. Exterior of Casing: Immediately after completion of the jacking operation, grout shall be injected through the grout connections of casings 30-inches in diameter and larger in such a manner as to completely fill all voids outside the casing pipe resulting from the jacking operation. Where loss of ground outside the casing is suspected, additional grout connections shall be welded to the casing. Grout pressure shall be controlled to avoid deformation of the casing and/or avoid

movement of the surrounding ground. After completion of grouting, the grout connections shall be closed with extra heavy black steel threaded plugs.

2. Interior of Casing (between carrier pipe and casing): After grouting the exterior of the casing and installing the carrier pipe, the interior of the casing shall be completely filled with grout if the casing depth is greater than 10-feet below the finished ground surface.

F. Installation of Carrier Pipe

1. Insertion of Carrier Pipe: After grouting the exterior of the casing pipe, the interior shall be cleaned and the carrier pipe installed. The carrier pipe shall be installed on two (2) skids of sufficient dimension to prevent the pipe bells from touching the casing pipe and to allow for proper alignment of the carrier pipe to meet the specified grade.
2. Securement: The top of the carrier pipe shall be blocked to prevent flotation. The carrier pipe shall be secured in a manner satisfactory to the District Representative to prevent floating and subsequent change of grade.
3. Pipe Skids and Blocking: Spacers shall be installed at mid-sections if the carrier pipe segment is over ten (10) feet long. Detailed product submittals showing all dimensions shall be provided to the District Representative for approval.
4. Grade Adjustment: The carrier pipe grade shall be adjusted as required by changing the height of the casing spacer riser and / or the thickness of the runner pad skids to compensate for any grade variations of the casing pipe. Care should be taken to ensure that the carrier pipe does not come in contact with and is insulated from the casing pipe.
5. Failure to Achieve Required Grade: If the alignment of the casing pipe is such that the carrier pipe grade cannot be met, the grade of the casing pipe shall, if required by the District, be adjusted. If realignment is not deemed feasible by the District, another casing pipe meeting the required grade shall be installed. The abandoned casing pipe shall be filled with sand and the ends plugged with twelve (12) inch thick masonry plugs. Realignment or replacement work shall in no way result in additional costs to the District.
6. Testing: Before backfilling the jacking and receiving pits, the carrier pipe shall have passed an initial pressure or leakage test in accordance with Section 15042, Hydrostatic Testing of Pressure Pipelines or Section 15043, Leakage and Infiltration Testing.

G. Closing the Jacking Pit and Receiving Pit

1. Closing the Jacking Pit and Receiving Pit: After jacking equipment and muck from the tunnel have been removed from the approach trench of jacking pit, the bottom of the jacking pit shall be prepared for pipe foundation and bedding. Remove all loose and disturbed material below pipe grade to undisturbed earth.

2. Backfill: The jacking pit and receiving pit represent overwidth trench conditions. Backfill shall be in accordance with Section 02223, Trenching, Backfilling and Compacting.

END OF SECTION

SECTION 02316: OPEN TRENCH CASING

PART 1 - GENERAL

A. Description

This section describes materials and installation of open trench casings. Jacked casing shall be installed in accordance with Section 02315, Jacked Casing.

B. Related Work Specified Elsewhere

1. Trenching, Backfilling, and Compacting: 02223
2. Jacked Casing: 02315
3. Hydrostatic Testing of Pressure Pipelines: 15042
4. Leakage and Infiltration Testing: 15043
5. Installation of Pressure Pipelines: 15051

C. Submittals

1. Shop drawings shall be submitted in accordance with the General Provisions and as specified herein.
2. For steel casing, submit manufacturer's mill specification sheet listing diameter, thickness, and class of steel used in making the casing, and the mill certification. For PVC casing, submit materials list showing material of pipe with ASTM reference and grade.
3. Submit drawings showing the location and type of joint for both casing and carrier pipe, and spacers.
4. If required, submit an engineered shoring plan. Shoring submittals shall be wet-signed and stamped by a California-licensed Civil or Structural Engineer.

D. Permits

All work shall conform to the specifications and requirements of the State of California Department of Transportation, the Orange County Planning & Development Services Department, the City, or the agency having jurisdiction. The Contractor shall secure all required permits for construction of casing pipe installation.

E. Line and Grade

Contractor shall survey pipe casing for conformance with design line and grade.

F. Delivery, Storage and Handling

1. The Contractor shall store PVC pipe or steel pipe casing in the field by the supporting the pipe uniformly per AWWA M23 or AWWA M11, respectively. Cover stored PVC pipe casing to protect it from the sun's ultraviolet radiation. Pipe which has been contaminated with any petroleum products (inside or outside) shall not be installed.
2. PVC pipe casing, which has been subjected to excessive ultraviolet radiation from the sun, shall not be used. The determination as to the acceptability of PVC pipe casing faded by the sun's radiation shall rest solely with the District Representative.
3. Proper care shall be used to prevent damage in handling, moving and placing the pipe casing. All pipe casing materials shall be lowered into the trench in a manner that prevents damage. The pipe casing shall not be dropped, dragged or handled in a manner that will cause bruises, cracks, or other damage.

PART 2 - MATERIALS

A. General

Pipe casing material and size shall be in accordance with the following table, unless otherwise specified on the drawings.

Casing Size and Material				
Nominal Carrier Pipe Size (inches)	Casing Material		Fill Annular Space between Casing and Carrier Pipe	
	Burial Depth to Top of Carrier Pipe			
	10-feet and less	Greater than 10-feet	10-feet and less	Greater than 10-feet
4-16	PVC	Steel	No	Yes
18-24	Steel	Steel	No	Yes

B. PVC Casing

1. Materials: Casing pipe shall be in accordance with AWWA C 900. The color of the PVC casing shall be blue for water, green for sewer, and purple for recycled water.
2. Wall Thickness: The wall thickness shall be DR 14 in accordance with AWWA C 900.

C. Steel Casing

1. Materials: Steel casing shall be ASTM A283 Grade C, ASTM A570 Grade 30 or 33, or ASTM A36 unless noted otherwise.

2. Joints & Welding: Casing sections shall be joined by full circumference welding. Field welds shall be full-penetration bevel welds in accordance with the standards of quality as set forth in the specifications of the American Welding Society. All welding shall be performed by skilled welders qualified under the provisions of ANSI/AWS D1.1. Welder qualifications shall be certified by an independent local, approved testing agency not more than 6 months prior to commencing work. Prepare ends of casings for proper bevel weld by providing a 45-degree bevel on the end of one of the two casing pieces being joined.
3. Wall Thickness: Minimum thickness of casing pipes shall be as shown in the IRWD Standard Drawings, unless a larger or heavier wall casing pipe is required by the agency having jurisdiction or the contractor requests use of a thicker wall pipe.

D. Pipe Skids and Blocking

Skids and blocking material requirements shall be in accordance with the pipe skid and blocking requirements of Section 02315, Jacked Casing.

E. Grout

Interior of Casing (between carrier pipe and casing): Grout shall consist of cellular concrete as manufactured by Cell-Crete Corporation. The cellular concrete shall have minimum compressive strength of 100 psi.

F. Casing Seals

1. When the casing is not filled with cellular concrete, the casing seals shall be 1/8-inch thick synthetic rubber designed to fit snugly around pipe and casing. Casing seals shall be either one piece with no field seams or wrap-around style to facilitate installation after the casing and carrier pipe are already installed. Bands and hardware for attachment of seal to pipe and casing OD shall be stainless steel.
2. When the casing is filled with cellular concrete, the casing seals shall be brick and mortar.

PART 3 – EXECUTION

A. Installation of Casing

1. Casing shall be installed in accordance with Section 02223, Trenching, Backfilling and Compacting.
2. Casing shall be lowered onto the bedding at the proper lines and grades to accommodate the specified lines and grades of the carrier pipe.
3. ID and Locator Tape: ID and locator tape shall be installed above the casing in accordance with Section 15151, Facilities Identification.

B. Installation of Carrier Pipe

1. Insertion of Carrier Pipe: After properly supporting the casing in the trench, the interior shall be cleaned and the carrier pipe installed. The carrier pipe shall be installed on two skids of sufficient dimension to prevent the pipe bells from touching the casing pipe and to allow for proper alignment of the carrier pipe to meet the specified grade.
2. Securement: The top of the carrier pipe shall be blocked to prevent flotation. The carrier pipe shall be secured in a manner satisfactory to the District Representative to prevent floating and subsequent change of grade.
3. Pipe Skids and Blocking: Skids and blocking shall be in accordance with the pipe skid and blocking requirements of Section 02315, Jacked Casing.
4. Grade Adjustment: The carrier pipe grade shall be adjusted as required by changing the height of the casing spacer riser and/or the thickness of the runner pad skids to compensate for any grade variations of the casing pipe. Contractor shall ensure that the carrier pipe does not come in contact with and is insulated from the casing pipe.
5. Annular Space between Carrier Pipe and Casing: The annular space between the carrier pipe and casing shall be filled with grout, when called for in the above "Casing Size and Material" table.

C. Grouting

1. Exterior of Casing: The exterior of the casing shall be backfilled and compacted in accordance with the Section 02223, Trenching, Backfilling and Compacting.
2. Interior of Casing (between carrier pipe and casing): After installing the carrier pipe and securely stabilizing the pipe with spacer, the interior of the casing shall be completely filled with grout. The grout shall be applied at a rate that maintains the line and grade of the carrier pipe and avoids floating the pipe.

END OF SECTION

SECTION 02528: CONCRETE CURBS, GUTTERS AND SIDEWALKS

PART 1 - GENERAL

A. Description

This section describes materials and construction of concrete curbs, gutters and sidewalks.

B. Related Work Specified Elsewhere

1. Trenching, Backfilling, and Compacting: 02223
2. Concrete Formwork: 03100
3. Concrete Reinforcement: 03201
4. Concrete: 03300
5. Concrete Finishing, Curing and Waterproofing: 03345

C. Submittals

Shop drawings shall be submitted in accordance with the General Provisions and the requirements of Section 03300, Concrete, Part 1-C.

PART 2 - MATERIALS

A. Forms

1. General: Forms shall be as required in Section 03100, Concrete Formwork. Stakes and braces shall be provided to hold forms securely in place.
2. Sidewalk Forms: Sidewalk forms shall be 2-inch dressed lumber, straight and free from defects, or standard metal forms. Where short-radius forms are required, 1-inch dressed lumber of plywood may be used.

B. Aggregate Base Course

Crushed rock base shall be clean 3/4-inch and smaller crushed rock or crushed gravel, free from foreign material, and conforming to Crushed Aggregate Base as specified by Standard Specifications of Public Works Construction: Section 400-2, latest edition.

C. Expansion Joint Filler

Premolded expansion joint filler shall be 1/4-inch thick for curbs and 1/4-inch thick for sidewalks, or as required or allowed by the permitting agency.

D. Concrete

Conform to Section 03300, Concrete.

E. Reinforcing Steel

Conform to Section 03201, Concrete Reinforcement.

F. Curing Compound

Conform to Section 03345, Concrete Finishing, Curing, and Waterproofing.

G. Excavation and Backfill

Conform to Section 02223, Trenching, Backfilling, and Compacting.

PART 3 - EXECUTION

A. Preparation of Subgrade

Subgrade shall be excavated and shaped to line, grade, and cross section. The top 12-inches of subgrade shall be compacted to 90% relative compaction. All soft material disclosed by excavating shall be removed and replaced with aggregate base as directed. The finished subgrade shall be within a tolerance of +/-0.02 of a foot of the grade and cross section shown and shall be smooth and free from irregularities at the specified relative compaction. The subgrade shall extend over the full width of the construction. The District Representative's approval of finished subgrades must be received prior to continuance of the work.

B. Placing Aggregate Base

After the subgrade for curbs, sidewalks, and roadway slabs is compacted and accepted, the Contractor shall place and spread aggregate base material, sprinkle with water, and compact to 90% relative density. The surface of the compacted base shall be at the proper level to receive concrete. Curbs and sidewalks shall be underlain by 4-inches or more of compacted aggregate base material.

C. Setting Forms

Forms shall conform to Section 03100, Concrete Formwork. Forms for a face-of-curb shall not have any horizontal joints within 7-inches of the top of the curb. Forms shall be braced to prevent change of shape or movement in any direction resulting from the weight of the concrete. Short-radius curved forms shall be constructed to exact radius. Tops of forms shall not depart from gradeline more than 1/8-inch when checked with a 10-foot straightedge. Alignment of straight sections shall not vary more than 1/8-inch in 10-feet.

D. Curb Construction

1. Jurisdictional Requirements: Curbs shall be reconstructed to original line and grade if removed. Curbs shall conform to the requirements of the respective jurisdictional agency.

2. Expansion Joints: Preformed asphalt-impregnated expansion joints shall be placed at 20-foot intervals, at the beginning and end of curved portions of the curb, at each change in thickness of section, at the end of curbs at buildings and other structures, and at connections to existing curbs.
3. Notification: The District Representative shall be notified one day in advance of planned concrete placement.
4. Concrete Finish: When the concrete has set sufficiently to support its own weight, the front form shall be removed and exposed surfaces finished. The formed face shall be finished by rubbing with a burlap sack or similar device to produce a uniformly textured surface, free of form marks, honeycomb, and other defects. Defective concrete shall be removed and replaced at no expense to the District. Upon completion of the finishing, curing compound shall be applied to exposed surfaces of the curb. Curing shall continue for a minimum of five days.
5. Backfill: Seven days (minimum) after pouring the concrete, the curb shall be backfilled with earth free from rocks, 2-inches and larger, and other foreign material. Backfill shall be tamped firmly in place.
6. Alignment and Grade: Finished curb shall have a uniform grade and alignment. Any section of curb showing abrupt changes in alignment or grade, or which is more than 1/4-inch away from its intended location, as staked, shall be removed and reconstructed at no additional cost to the District.
7. Protection of Work: All concrete surfaces and/or structures shall be protected until the project containing the work is accepted.

E. Sidewalk Construction

1. General Requirements: Unless shown otherwise, sidewalks shall be placed in a single pour, 4-inches thick. Walks shall slope 1/4-inch per foot upward from the top of curb. Concrete shall be placed, processed, finished, and cured in conformance with the applicable requirements of ACI 614, latest edition.
2. New Sidewalk: Where new sidewalk is to abut existing concrete, the existing concrete shall be sawcut to a depth of 2-inches and the concrete chipped out to sound material and a plane surface. The surface shall be cleaned and a neat cement paste applied just prior to pouring the new sidewalk.
3. Expansion Joints: Preformed expansion joints shall be placed at 20-foot intervals or less to match those in the adjacent curb, where the sidewalk ends at a curb, and around posts, poles, or other facilities located within the sidewalk. Expansion joints shall be placed between sidewalks and buildings or other structures.
4. Contraction Joints: Contraction joints shall be provided transversely to the walks at locations opposite the contraction joints in the curb and at 10-foot intervals along the sidewalk. These joints shall be 3/16-inch by 1-inch weakened plane joints. They shall be straight and at right angles to the top of the walk.
5. Notification: The District Representative shall be notified one day in advance of planned concrete placement.

6. Concrete Finish: The top surface of the sidewalk shall receive a broom finish with a fine-hair broom in line with the length of the walk. All edges, joints, and markings shall be tooled. The walk shall be scored transversely at 5-foot intervals with a jointing tool. Upon completion of the finishing, an approved curing compound shall be applied to exposed surfaces. Sidewalks shall be protected from damage until final acceptance.

END OF SECTION

SECTION 02578: PAVEMENT REMOVAL AND REPLACEMENT

PART 1 - GENERAL

A. Description

This section describes materials, testing, removal, and replacement of asphalt concrete pavement, seal coat, aggregate base course, prime coat, tack coat, and Portland Cement Concrete (PCC) surfaces.

This revision reflects incorporation of the California and CalTrans standards (Standard Specifications) and the Standard Specifications for Public Works Construction, (SSPWC) latest edition, for specifying performance grade (PG) asphalt. The Contractor shall comply with SSPWC and the modifications to SSPWC specified herein.

For projects located in the public right-of-way, the respective City's pavement specification and/or approved encroachment permit requirements shall take precedence over the requirements specified herein.

B. Related Work Specified Elsewhere

1. Trenching, Backfilling, and Compacting: 02223
2. Concrete Curbs, Gutters, and Sidewalks: 02528
3. Standard Specifications for Public Works Construction, latest edition.

C. Submittals

1. Shop drawings shall be submitted in accordance with the General Provisions and as specified herein.
2. Mix Design: Submit asphalt mix design data prepared within the last year by a certified laboratory acceptable to District for each asphalt concrete material type used on the project.
3. Materials Quality: Submit materials certificates signed by material producer and Contractor, certifying that each material item complies with, or exceeds, specified requirements.
4. Materials Source: Submit materials certificates signed by material producer and Contractor, identifying material producer by name, location of material producing plant, and type of plant from which material will be produced and delivered.
5. Guarantee: Submit completed manufacturer's warranty form providing an unconditional installation guarantee for a period of no less than two (2) years beginning from the date of the Notice of Completion.
6. Submit proposed pavement placement sequence and schedule.

PART 2 - MATERIALS

A. Asphalt Concrete Paving

The Dense Graded Asphalt Concrete (DGAC) material used for all areas shall comply with the requirements of the SSPWC, latest edition, and as modified herein. The specific type of material used for each type of construction shall comply with the table below. The Contractor shall supply, unless otherwise instructed, a mix with less than or equal to 15% Recycled Asphalt Products (RAP). Asphalt shall be performance grade PG 64-10. Asphalt binder content in the pavement shall be in accordance with Section 203 in the SSPWC. The base course shall be a minimum of 3-inches thick.

Requirement for Asphalt Concrete Material Type			
Pavement Thickness (inches)	≤1	>1 and ≤2	>2
SSPWC Material Type (for use in AC Cap):	T3DPG*	T3C3PG**	T3C3PG**
SSPWC Material Type (for use in AC Base):	-	-	T3B3PG***

* T3DPG: Type III D PG 64-10 Asphalt Concrete per Section 203 of the SSPWC.

** T3C3PG: Type III C3 PG 64-10 Asphalt Concrete per Section 203 of the SSPWC.

*** T3B3PG: Type III B3 PG 64-10 Asphalt Concrete per Section 203 of the SSPWC.

Warm Mix Asphalt Concrete mix may be utilized only for the asphalt concrete base courses of the project.

B. Aggregate for Asphalt Concrete

Aggregate shall be in accordance with Section 203 of the SSPWC.

C. Seal Coat

Seal coat material shall be a plant-blended product composed of mineral aggregates uniformly distributed in a petroleum-base asphalt emulsion. The asphalt emulsion shall conform to Section 203-3 of the SSPWC, and shall be free of asbestos fibers or coal tar additives. Seal coat materials, undiluted except as noted, shall conform with the SSPWC Section 203-9. In complying with the seal requirements, the seal shall have a minimum of 60% non-volatiles at the delivery from the supplier and 48% non-volatiles at the point of seal material placement.

D. Aggregate Base Course

All crushed miscellaneous base material placed on site shall have a minimum R-value of 80. Crushed miscellaneous base must also meet requirements in SSPWC, Section 200. Compaction tests will be performed by the District, unless otherwise specified in the General Requirements, and require approval before the surface layer of asphalt concrete is placed.

E. Cement Treated Base

The use of a Cement Treated Base (CTB) shall be designed in a laboratory by an independent laboratory in accordance with Section 301-3 of the SSPWC. The determination of a design shall be performed with a minimum of four (4) soil cement mixtures in order to determine the optimum cement content for the soil. The report shall also detail the depth of mixing and compaction requirements.

F. Crack Treatment

Construction materials shall consist of a combination of a crack filling emulsion and that of asphalt concrete material for filling the milled areas according to the following schedule.

1. Crack widths equal to or greater than 1/4-inch but less than 1/2-inch.

A hot applied crack fill material shall be placed in all cracks.

2. Crack widths equal to or greater than 1/2-inch.

The crack fill material shall be a Type D2 PG 64-10 asphalt concrete material, per Section 203-6 of the SSPWC.

G. Tack Coat

The tack coat shall be diluted SS-1h Emulsion per Section 203-3 of the SSPWC.

H. French Drain Construction

The PVC Drain Pipe used in all French Drain areas shall comply with ASTM D2665 and ASTM D1785. The pipe shall be slotted and interlocking.

I. Geotextile Fabric

The geotextile fabric used in all French Drain areas shall be a Mirafi 140.

J. Engineering Fabric & Overlay

1. Binder Coat (New DGAC Overlay & Fabric to existing Asphalt Concrete)

The binder coat shall be a PG 64-10 material. The Binder Coat shall be a “trackless material” capable of bonding between and through the engineering fabric and asphalt concrete overlay.

2. Fabric (New DGAC Overlay & Fabric to existing Asphalt Concrete)

All engineering fabric shall conform to Section 213 of the SSPWC.

K. Portland Cement Concrete Slab on Grade

PCC materials shall be placed in accordance with Section 303 of the SSPWC, and have a maximum slump of 4-inches. PCC elements shall be protected from graffiti marks until after a set and hardened condition has occurred.

Pavement crack control jointing for curbs and gutters shall be placed at a maximum of 8-feet on center for all slab on grade in all directions.

Slab on grade jointing and expansion joints shall be as specified on the plans. Slab on grade PCC elements construction joints shall be doweled with No. 4 bar (smooth) fixed at one end with dowel spacing of 18-inches on center and 18-inches away from every corner. Slab on grade PCC materials shall have the additive of 1.5 lb/cy of “Buckeye UltraFiber 500” concrete reinforcing fiber additive containing the following minimum requirements.

- a) Material:Alkali-resistant, virgin cellulose fibers.
- b) Average Length:2.1 mm (0.083 inch).
- c) Average Denier: 2.5 g/9,000 m.
- d) Average Diameter: 18 μ (0.63 x 10⁻³ inch).
- e) Count:1,590,000 fibers/g (720,000,000 fibers/pound).
- f) Density:1.10 g/cm³.
- g) Surface Area:25,000 cm²/g (12,200 ft²/pound).
- h) Average Tensile Strength:750 N/mm² (110 ksi).
- i) Average Elastic Modulus:.....8,500 N/mm² (1,200 ksi).
- j) Fiber Spacing:550 μ m at 0.9 kg/m³ dosage rate (0.026 inch at 1.5 pounds/cubic yard dosage rate).

All reinforcing fibers shall be placed into the concrete mixture in accordance with manufacturer's instructions and ASTM C94. The application rate of the material shall be 1.0 pounds/cubic yard (0.6 kg/m³) of concrete directly into concrete mixer at beginning of batch cycle. The mixing process shall be a minimum of 4 minutes at mixing speed in the concrete mixer for full reinforcing fiber dispersion.

Poly Foam is required where there is new PCC against existing elements of PCC, stucco, brick, block, or steel materials. Abutments shall be separated during construction with the Poly Foam and removed after the PCC has set to a depth of 1/2-inch. The void area created by the removal of the Poly Foam shall then be backfilled with an approved elastomeric material of matching color for the designated area.

L. Striping

Paint shall conform to Section 214-4 of the SSPWC. Paint color and type shall be as indicated on the drawings, or if not indicated, shall match as nearly as practical the existing conditions of the site.

M. Root Barrier

The root barrier shall consist of the active chemical: Trifluralin (a,a,a-Trufluro 2,6 – dinitro – N,N, - Dipropyl – p –toluidine) 17.5%. Inert ingredients: 100% Spunbonded Polypropylene, polyethylene and Carbon 82.5%. Root barrier shall be Typar Biobarrier.

N. Redwood Header

Redwood headers shall comply with the material requirements of the SSPWC.

O. Water for Compaction

Water used to assist in compaction and subgrade preparation shall conform to Section 02223, Trenching, Backfilling, and Compacting.

PART 3 - EXECUTION

A. Pavement Removal

1. Public Safety: The Contractor shall comply with all applicable, State, County and City requirements for temporary closures of streets, parking lots, or other areas. The Contractor shall provide barriers, guards, light, signs, temporary bridges, flag persons and watch persons, advising the public of detours and construction hazards. The Contractor shall furnish and install, and upon completion of the work, promptly remove all signs and warning devices. The Contractor shall comply with all the public safety and signing requirements specified in the SSPWC, and the California Manual on Uniform Traffic Control Devices, latest edition. Should two or more specifications be in conflict, the more restrictive of the two shall be followed.
2. NPDES: Compliance with National Pollutant Discharge Elimination System (NPDES) storm water permit program shall be the responsibility of the Contractor. The Contractor shall be required to implement and meet best practice standards for all discharge in to the storm drain system.
3. Project Cleanliness: The Contractor shall ensure that all areas of the site are kept clean of debris and construction materials outside of the region designated for storage and staging. Upon the conclusion of the project, the Contractor shall ensure that all curbs, sidewalks, cross gutters, decorative slab on grade, signs, landscaping drive approaches, etc., are returned to their pre-construction condition and/or new construction status having no marks or material coatings unless designated otherwise. The Contractor shall clean these areas if requested to do so by the District Representative prior to the final completion of the project.
4. Asphalt Concrete Pavement Cutting Requirements: Asphalt concrete pavement shall initially be cut with a pavement cutter or other equipment at the limits of the excavation before the pavement is removed. After backfilling and compacting the excavation, asphalt concrete pavement shall be saw cut to a minimum depth of 2-inches at a point not less than 9-inches outside the limits of the excavation or the previous pavement cut, whichever is greater, and the additional pavement removed. If the cut is within 3-feet of an existing joint or curb and gutter, the asphalt concrete pavement shall be replaced to the joint or curb and gutter. Saw cut lines shall be parallel or perpendicular to the flow of traffic.
5. Portland Cement Concrete Pavement Cutting Requirements: Concrete pavement, cross gutters, curbs and gutters, sidewalks, or driveways, shall be saw cut to a minimum depth of 1 1/2-inches at a point 1-foot beyond the edge of the excavation and the strip of improvement removed. Concrete pavement may initially be cut at the limits of the excavation by other methods prior to removal and the saw cut made after backfilling the excavation. If the saw cut falls within 3-feet of a concrete joint or pavement edge, the concrete shall be removed and replaced to the joint or edge.

6. Disposal of Material: All pavement and other improvements demolished shall be removed from the site and disposed of in a manner acceptable to agencies having jurisdiction over the work and to the District.
7. Final Pavement Saw Cuts: Excavation shall be regular and rectangular in shape and shall be blade-cut or saw-cut, as appropriate to the field conditions through the existing pavements. Cuts shall be made in straight lines. Excavation shall be taken to the limits identified on the site drawings. Excavation material shall be hauled from the job site. Removal shall be considered as Unclassified Excavation.

B. Pavement Replacement

1. General: Producing, hauling, placing, compacting, and finishing of asphalt concrete shall conform to Section 302-5 of the SSPWC.
2. Base Course, Final Course and Striping: Base course paving shall be complete at all times to a point not to exceed 1,000 feet behind any working heading. Temporary striping shall be applied after the base course of asphalt concrete pavement has been placed, in the same configuration as the existing permanent striping, so that traffic can be returned to normal patterns. Temporary striping shall be maintained until permanent striping is applied.

C. Preparation of Subgrade

After rough grading has been completed, the subgrade and/or aggregate base shall be loosened to a depth of at least 6-inches. The loosened material shall be worked to a finely divided condition and all rocks larger than three 3-inches in diameter shall be removed. The moisture content shall be brought to optimum by the addition of water, by the addition and blending of suitable material or by the drying of existing material. Subgrade for base material shall not vary by more than 0.04 foot from the specified grade and cross section limits. Variations within the above specified tolerances shall be compensating so that the average grade and cross section limits are met. The Contractor shall receive written approval of grade from the District Representative prior to proceeding with any subsequent work. Grade approval shall be received for subgrade and base grade. The material shall then be compacted by approved equipment to 90% of laboratory maximum at or near optimum moisture as determined by ASTM D1557, ASTM D1556 and/or ASTM D2922. The subgrade must be firm and unyielding before the base and/or surface courses are placed. Base material shall be compacted to 95% of laboratory maximum at or near optimum moisture as determined by ASTM D1557, ASTM D1556 and/or ASTM D2922. Asphalt placed on subgrade materials shall have subgrade compacted to 95 percent of laboratory maximum at or near optimum moisture as determined by ASTM D1557, ASTM D1556 and/or ASTM D2922.

Final grade cross fall shall be a minimum 2% from the centerline of the roadway to the edge of the gutter lip, unless otherwise specified on the plans. The grade shall be finished to permit the final PCC gutter lip finish surface at 3/8-inch above said lip.

D. Placing Aggregate Base

Aggregate base shall be placed to the thickness shown on the plans or to match existing. Aggregate base shall be compacted to 95% relative compaction and installed in maximum of 6-inch lifts in accordance with Section 301-2 of the SSPWC.

E. Placing Geotextile Fabric

The geotextile fabric shall be placed, only after approval has been given to proceed with trench construction. The fabric shall be placed on the ground and up along the edges of the 12-inch wide by 18-inch depth trench. The Contractor shall take care in placing the aggregate backfill in order to not puncture or tear the fabric. The fabric shall be laid over itself on the top such that the overlap is a minimum of 6-inches. Additional aggregate shall be placed upon the top of the fabric overlap a maximum of 3-inches. This top layer of aggregate shall separate the bottom of the asphalt concrete and the fabric overlap area.

F. Placing Portland Cement Concrete

Placement of the PCC material shall be in accordance with Section 302-6 of the SSPWC. PCC curbs, gutters and slab on grade elements shall be constructed by use of forms, with transverse expansion and construction joints. Finish PCC surface areas, with the exception of flow line areas, shall be provided with a pavement medium broom finish surface unless otherwise directed by the District Representative.

Where traffic loading is expected, doweling shall be required for slab on grade elements by use of approved smooth No. 4 bars, greased at one end and fixed at the other. Dowels shall be constructed at 18-inch intervals on center and no closer than 18-inches from pavement corners.

PCC elements shall be protected from graffiti marks until after a set and hardened condition has occurred. Contractors failing to protect the PCC elements from graffiti shall be liable to remove and replace each PCC element affected.

G. Placing Tack Coat

Tack coat shall be applied at the rate of 0.05 gallons per square yard to the surfaces to receive finish pavement per Section 302-5.4 of the SSPWC. Tack coat shall be applied to existing asphalt, metal, or concrete surfaces that will be in contact with new asphalt concrete paving.

H. Placing Asphalt Concrete Material

Asphalt paving shall be applied to the thickness shown on the plans, as listed above, or per the applicable permit. Asphalt paving shall be installed in accordance with Section 302-5 of the SSPWC.

Asphalt concrete shall be placed in lifts having a maximum of 4-inches. Work shall be performed in accordance with Section 302-5 of the SSPWC. A tack coat of SS-1h shall be placed between all lifts and on all vertical faces.

The new finish surface of asphalt concrete shall be 3/8-inch above PCC curbs and gutters.

The asphalt concrete mat paving machine shall have a vibratory plate in operation during all of the laydown operations. In the case that the plate is non-operational, the Contractor shall increase the thicknesses to include an additional 1/16 of an inch for each inch of asphalt concrete material placed.

Use of Warm Mix Asphalt Concrete will alter the minimum permissible arrival temperature at the time of rolling. The temperature of the Warm Mix Asphalt Concrete shall be greater than 240°F at the time of placement.

I. Placing Binder and Engineering Fabric

1. **Binder Coat:** The entire surface to be covered shall be free of water, foreign matter, vegetation or dust before application of the tack coat.

Hot PG 64-10 oil shall be applied prior to placing the engineering fabric. The binder coat of asphalt cement shall be placed at a uniform spread rate of 0.25 gallon per square yard (+/- 0.02 gal/sy) in areas of the project to receive the engineering fabric and subsequent overlay.

The binder coat shall be placed with the aid of a truck sprayer application. The width of the sprayer application shall be no more than 6-inches and no less than 2-inches wider than the fabric width to be placed.

2. **Engineering Fabric:** Engineering fabric shall be placed in accordance with SSPWC, Section 302. A binder coat shall be placed prior to the placement of the fabric. Fabric shall be placed with a minimum 6-inch overlap. No greater area shall be treated in any one day than is planned to be covered by asphalt concrete during the same day. The engineering fabric shall overlap all transverse and longitudinal joints by a maximum of 4-inches and a minimum of 2-inches. The minimum width of a cut roll that is placed, shall be 4-feet. A cut roll may be required if it is necessary for the Contractor to overlap a joint. The engineering fabric shall not be placed in any area where the intended or as-built overly thickness is less than 1 1/2-inches and shall be placed only in thicknesses as designated on the contract agreement.

Fabric shall be placed with no wrinkles that lap. The test for lapping shall be made by gathering the fabric in a wrinkle. The two sides of the wrinkle shall be pressed together from pavement surface to a fold point with equal amounts of fabric on both sides of the fold point down to the pavement surface. If the height of the double portion of the extra fabric exceeds 1/2-inch, the fabric shall be cleanly cut to remove the wrinkle. The cut shall be made on the side.

Pavement fabric shall not be placed more than 600-feet in advance of the paving operations. No more fabric shall be placed than can be covered in one day.

J. Applying Seal Coat

Pavement seal coat shall be applied on existing pavement where shown on the plans and on all new pavement. Pavement seal operations shall be performed in accordance with the manufacturer's recommendations. The material spread rate shall be a minimum of 25 gallons per 1,000 square feet and shall be placed in a minimum of two coats.

Prior to sealing, the Contractor shall remove existing traffic striping and pavement markings by wet or dry sandblasting, high velocity water jet, grinding, or other approved methods. This procedure is intended to prevent the shadow effect that occurs due to the old lines or stripes wearing through the new sealed surface.

K. Surface Tolerance

Finished grade shall not deviate more than 0.02 foot in elevation from the grade indicated on the drawings. Slopes shall not vary more than 1/8-inch in 10-feet from the slopes shown on the drawings.

L. Concrete Curbs, Gutters, and Sidewalks

Concrete curbs, gutters, and sidewalks shall be replaced in accordance with Section 02528, Concrete Curbs, Gutters, and Sidewalks.

M. Emulsion-Aggregate Slurry

Certain street sections, where shown on the plans or where required by the jurisdictional agency, may be required to receive an asphaltic slurry seal in conformance with Section 302-4, SSPWC after the final asphalt surface course. The composition and aggregate grading for slurry shall be Type II of Subsection 203-5.3. Unless otherwise directed by the jurisdictional agency, the contractor shall wait 30 calendar days, after installing pavement, before applying the emulsion-aggregate slurry on new pavement.

N. Placing PVC Drain Pipe for French Drain System

The PVC drain pipe shall be constructed in continuous connection from the bottom of the grade to the top of the grade away from catch basin. The pipe shall have two parallel rows of perforations (round or elongated holes) on the down side of the pipe about 120 degrees apart. The perforated pipe shall have four 4-inches of cover below the bottom of the trench.

O. Pavement Milling

Tapered Header Cuts: Areas designated for placement of a 2-inch asphalt concrete overlay shall have a minimum 6-foot tapered cut at roadway edges. At the transition from paving to non-paving, the tapered cut shall be a minimum width of 12-feet wide. At the lip of gutter and asphalt concrete pavement interface, the asphalt concrete overlay shall be 3/8-inch higher than the lip of gutter. The milled surface within the taper shall be uniform, shall not vary from its highs and lows by more than 3/8-inch, and shall be performed in accordance with Section 302 of the SSPWC. A temporary cold mix ramp shall be constructed after the pavement is milled and before the cap is placed.

P. Slurry Cement Backfill

Slurry cement backfill patch material shall be placed and constructed with care and be permitted to set and cure without being disturbed.

Q. Placing Crack Fill Materials

1. Crack widths greater than 1/4-inch but less than 1/2-inch.

A hot applied crack fill material shall be placed in all cracks. Hot rubber crack fill material shall be filled to within 1/4-inch of the finish surface. The Contractor shall take care not to excessively place crack fill material along the edges of the crack at the finish surface. Excessive crack fill over splash shall be removed under the direction of the District Representative. Crack filling operations shall only be performed during the Winter or early Spring months unless otherwise directed by the District.

2. Crack widths equal to or greater than 1/2-inch.

Prior to crack filling, the existing cracks shall be marked out. Cracked areas shall be milled out to a depth of 3-inches and a width of 18-inches. Each area shall then

be cleaned and all vertical and horizontal areas shall then be tack coated with an SS-1h material and permitted to “break” before any new asphalt concrete material is applied. The new asphalt concrete material shall be placed in one lift, compacted and brought to the finish surface of the existing pavement.

R. Painting

PCC curbs that will receive a new coat of paint shall be scraped to loosen all paint chips and debris prior to painting.

Paint, except for black out line paint, shall be placed in a minimum of two coats per Section 314 of the SSPWC. The two coats shall be applied a minimum of one week apart from one another. Black out line paint shall be applied per SSPWC, Section 214.

S. Place Root Barrier

Root barrier shall be protected from ultraviolet rays and shall be stored in accordance with the manufactures recommendations. Materials shall not be removed from their shipping container until placement. The root barrier shall be a minimum of 18-inches deep from the finished surface.

T. Redwood Header

Redwood headers shall be placed at a maximum spacing of 48-inches on center. The placement of headers, stakes, and joint splicing shall be in accordance with the SSPWC.

U. Inspection and Testing

1. Conformity with Contract Documents: Work and materials shall conform to the lines, grades, cross sections, dimensions and material requirements including tolerances, shown on the plans and as specified herein.
2. Advance Notice: At least forty-eight (48) hours advance notice shall be given when requesting inspection of work. No paving or concrete operations shall be permitted except in the presence of a District Representative.
3. Access for Inspection and Testing: The Contractor and material producer shall, at all times, provide safe access for inspection of the work by the District Representative to any shops, production plants, or areas where materials or portions of the work are in progress. The District Representative shall be given assistance as necessary for performing tests, and shall be kept apprised of work schedules.
4. Materials Testing: Unless otherwise specified in the General Requirements, the District will provide materials testing in accordance with the current published methods as specified and used by the following agencies:
 - a. American Society for Testing and Materials (ASTM)
 - b. American Association of State Highway and Transportation Officials (AASHTO)

- c. Test Methods as developed by Materials and Research Department - California Department of Transportation - Division of Highways, Sacramento, California,

Testing of materials shall include, but not be limited to, material gradation, binder content, and compaction. In the event of a failed test, the Contractor shall be responsible to pay for all costs associated with retesting.

- 5. Samples: In general, samples for testing will be taken by the District Representative from material at the production plant and/or material delivered to the site of the work, and such material should be available in ample time to allow for such testing. In the event that control testing for the work is performed by a private laboratory, the District reserves the right to stipulate the number and location of the control tests which will relate to ultimate acceptance of the work by the District.
- 6. Removal of Rejected and Unauthorized Work: Work which has been rejected shall be remedied, or removed and replaced in an acceptable manner as determined by the District Representative. Any work done beyond the lines and grades shown on the plans or established by the Engineer, or determined by the District Representative to not be of acceptable material quality, or of acceptable workmanship, or any work done without written authority shall be considered as rejected work. Upon order of the District Representative, work shall be remedied, removed, or replaced at no expense to the District.
- 7. Equipment: The Contractor shall provide adequate and suitable equipment to meet the requirements of the Contract Documents.

END OF SECTION

SECTION 02701: INSTALLATION OF GRAVITY SEWER PIPELINES

PART 1 - GENERAL

A. Description

This section describes the installation of gravity sewer pipelines fabricated of vitrified clay pipe (VCP) and polyvinyl chloride (PVC).

B. Related Work Described Elsewhere

1. Trenching, Backfilling, and Compacting: 02223
2. Jacked Casing: 02315
3. Open Trench Casing: 02316
4. Vitrified Clay Pipe for Gravity Sewers: 02710
5. PVC Pipe and Fittings for Gravity Sewers: 02715
6. Concrete: 03300
7. Precast Concrete Manholes and Bases: 03461
8. Leakage and Infiltration Testing: 15043
9. PVC Pressure Pipe and Fittings: 15064
10. Facilities Identification: 15151

C. Submittals

1. Shop drawings shall be submitted in accordance with the General Provisions and as specified herein.
2. An installation schedule in a tabulated layout format shall be submitted and shall include the following.
 - a. Order of installation and closures.
 - b. Pipe centerline station and elevation at each change of grade and alignment.
 - c. Locations of manholes.

PART 2 - MATERIALS

A. Installation Material

Refer to Section 02710, Vitrified Clay Pipe for Gravity Sewers and Section 02715, PVC Pipe and Fittings for Gravity Sewers for material requirements.

B. Piping Schedule

Unless noted otherwise on the plans or in the specifications, pipe shall be furnished in accordance with the following materials schedule. The minimum pipe length for SDR 35, DR 14, and DR 18 shall be 20-feet.

Diameter	Acceptable Materials
4-inch through 15-inch	Extra-Strength VCP; PVC SDR 35 For depths 20-feet and deeper: PVC C900 DR 14 or DR 18
16-inch through 20-inch	Extra-Strength VCP; PVC C900 DR 18
24-inch through 42-inch	Extra-Strength VCP; PVC C-900 DR 18 (thru 30-inch diameter); CCFRPM Pipe (Hobas); Polymer Concrete Pipe (Meyer); Fiber-Reinforced Plastic
Greater than 42-inch	CCFRPM Pipe (Hobas); Polymer Concrete Pipe (Meyer); Fiber-Reinforced Plastic

For PVC pipe, the color shall be green.

PART 3 - EXECUTION

A. Delivery and Temporary Storage of Pipe at Site

1. Onsite Storage Limitation: Onsite pipe storage shall be limited to a maximum of two weeks, unless exception is approved by the District Representative.
2. Care of Pipe: At times when the pipe laying is not in progress, the open end of the pipe shall be closed with a tight-fitting cap or plug to prevent the entrance of foreign matter into the pipe. All plastic pipe and fittings shall be stored under a cover in a flat, horizontal position, and protected from the sun and the elements until ready for installation.
3. Use of Pipe: In no event shall the sewers be used as drains for removing water which has infiltrated into the construction trenches.

B. Handling of Pipe

1. Moving Pipe: Pipes shall be lifted with handling beams or wide belt slings as recommended by the pipe manufacturer. Cable slings shall not be used. Pipe shall be handled in a manner to avoid damage to the pipe. Pipe shall not be dropped or dumped from trucks or into trenches under any circumstances.

2. Inspection of Pipe: The pipe and accessories shall be inspected for defects prior to lowering into the trench. Any defective, damaged or unsound pipe shall be repaired or replaced. All foreign matter or dirt shall be removed from the interior of the pipe before lowering into position in the trench.

C. Placement of Pipe in Trench

1. General: All pipe shall be laid without a break, upgrade from structure to structure, with the bell ends of the pipe upgrade. Pipe shall be laid to the line and grade given so as to form a close concentric joint with the adjoining pipe and prevent sudden offsets of the flow line.
2. Trench Excavation: Dewatering, excavation, shoring, sheeting, bracing, backfill material placement, material compaction, compaction testing, and pipe laying requirements and limitations shall be in accordance with Section 02223, Trenching, Backfilling, and Compacting.
3. Pipe Base Thickness: Unless shown otherwise on the drawings, pipe base material shall be 3/4-inch crushed rock as specified in Section 02223, Trenching, Backfilling, and Compacting.
4. Subgrade at Joints: At each joint in the pipe, the pipe subgrade shall be recessed in firm bedding material so as to relieve the bell of the pipe of all load and to ensure continuous bearing along the pipe barrel.
5. Cleaning: The interior of the sewer pipe shall be cleaned of all dirt and superfluous materials as the work progresses.
6. Joints: The mating surfaces of the pipe to be joined shall be wiped clean of all dirt and foreign matter and a lubricant applied that is approved by the pipe manufacturer. Then, with the surfaces properly lubricated, the spigot end of the pipe shall be positioned inside the bell. For larger diameter pipe where a lever attachment is required, the necessary precautions shall be taken to ensure an undamaged pipe installation.
7. Pipe Alignment: Unless specified otherwise, pipeline line and grade shall be as shown on the plans. Grade shall be measured along the pipe invert.
8. PVC Pipe Curvature: Construction of curved reaches of PVC pipe may be accomplished by deflecting joints. Pipe deflection to achieve horizontal curves shall be limited by the manufacturer's maximum recommended limit or as follows, whichever provides the largest radius and the least deflection:

Diameter (inches)	Radius (feet)
6	210
8	280
10	350
12	420

9. Short Lengths of VCP Pipe: When using VCP, two 1-foot lengths of sewer pipe shall be used to provide curve flexibility and prevent cracking or shearing failures as shown on the plans or as may be required by the District Representative during construction. The use of short lengths of pipe is particularly required, but not

necessarily limited to these locations: (1) inlets and outlets to all manholes; and (2) ends of steel casing pipe.

10. Laterals: VCP and PVC wyes, and other types of branches shall be furnished and installed along with the VCP or PVC sewer main. Wyes sized as specified on the plans shall be installed for all sewer lateral connections and for future sewer lateral connections as shown on the plans. The longitudinal barrel of branch fittings, to be placed in line and grade with the sewer mains, shall be of the same diameter, quality, and type as specified herein for sewer installations. Earthwork and bedding for branches and shall conform to the applicable provisions set forth for vitrified clay sewer pipe. Unless otherwise specified, the branch of wye fittings shall be inclined upward at an angle not greater than 45 degrees from a horizontal line. No wye for sewer lateral branch shall be placed closer than 5 feet downstream of the centerline of any structure.
11. Backfill: Backfill shall be placed and compacted in accordance with the requirements of Section 02223, Trenching, Backfilling and Compacting, and as shown in IRWD Standard Drawings.

D. Manholes and Manhole Bases

Precast concrete manholes and manhole bases shall be constructed in accordance with Section 03461, Precast Concrete Manholes and Bases, as shown in the plans or on IRWD Standard Drawings.

E. Sewer Laterals with Lateral Clean-outs

1. Locations: Sewer laterals and wye branch fittings of the size indicated on the plans shall be installed at the locations shown on the plans or at the location furnished by the District Representative.
2. Wye-Branches for Future Laterals: All branch fittings that are to be left unconnected shall be plugged with a manufactured plug as shown in IRWD Standard Drawings and as approved by the District Representative.
3. Fittings: Sewer laterals shall be joined to wye branch fittings at the sanitary sewer main as set forth above by eight bends and as shown in IRWD Standard Drawings. A wye branch fitting at or near the property line (right-of-way limit) or easement boundary, shall be set on each sewer lateral to allow the clean-out riser and cover to be brought up to grade for each lateral connection.
4. Alignment: Where possible, all sewer laterals shall run perpendicular to the sewer main to the property line. All sewer lateral trenches shall be bedded the same as the sewer main.
5. Plugged Sewer Laterals: All sewer laterals shall be plugged with an approved stopper or cap at the last joint of each lateral. It shall withstand the internal pressure during the test for leakage. It shall be installed in such a manner that it may be removed without damaging the pipe.
6. Marking: The Contractor shall mark the location of each sewer lateral near its upstream end by grinding a 2-inch tall letter "S" on the face of the curb (where a curb exists). The installation of ID tape, locator tape, and tracer wire over the

trench line for lateral piping is also required in accordance with Section 15151, Facilities Identification.

Where housing tracts, commercial subdivisions call for an extended time delay between District sewer construction and private on-site construction, each lateral shall be marked with a "utility marker paddle" labeled "SCO" as shown in IRWD Standard Drawing G-2, at or near the property line.

7. Chimney Connections: Chimney connections of any kind (where sewer connections drop waste directly and vertically into the sewer main) are not allowed.

F. Terminal Cleanouts

1. Limitations: The use of terminal cleanouts (not to be confused with lateral cleanouts) shall be limited to the following:
 - a. A short section (less than 250 feet) of sewer main that is to be extended.
 - b. At the end of a sewer main where the distance from the downstream manhole to the cleanout does not exceed 250 feet.

G. Installation Within Casing

1. General: The carrier pipe shall be installed within the casing pipe to the lines and grades shown on the plans and in accordance with Section 02315, Jacked Casing, or Section 02316, Open Trench Casing.
2. Pipe Support: The carrier pipe shall be supported on skids, before backfilling, in such a manner as to relieve the pipe bells from any bearing loads. Pipe skids for "carrier pipe" shall be as specified in Section 02315, Jacked Casing, or for open trench installations, Section 02316, Open Trench Casing, and as shown in IRWD Standard Drawings.
3. Grouting Interior and Exterior of Casing: Refer to Section 02315, Jacked Casing and Section 02316, Open Trench Casing for grouting requirement on the interior and exterior of the casing.
4. Testing: Before backfilling the trench and bore pits, or sealing the casing ends, the sewer carrier pipe shall pass an initial test for leakage in accordance with Section 15043, Leakage and Infiltration Testing.

H. Concrete Slope Anchors

1. General: Concrete slope anchors shall be installed where shown on the plans in accordance with Section 03300 and as shown in IRWD Standard Drawings.
2. Slope Protection: Any required surface slope protection shall be reviewed and approved in advance by the District Representative.
3. Sand Cement Slurry: At the direction of the District Representative, a one-sack sand cement slurry encasement may be used for additional slope and erosion

protection. The encasement shall extend to within 1-foot of the ground surface and to the toe of slope in which the pipe is constructed.

I. Concrete Encasement

Unless shown otherwise, concrete for encasement shall be reinforced or unformed or rough formed, and of the class as designated on the plans. Concrete shall be in accordance with Section 03300, Concrete. Concrete used for encasing, cradling, bedding, cover for pipe, or other objects shall be as designed by the Engineer, or as directed by the District Representative. Encasement is by special permission from the District and in no case shall it be installed on VCP sewer pipes.

J. Cleaning

Before testing, and after each phase of development (or tract), each pipe shall be thoroughly cleaned from manhole to manhole with a sewer scrubbing ball, and all debris and trash shall be removed from each manhole.

K. Mandrel Test for PVC Gravity Sewers

Following placement and compaction of backfill for all utilities, and prior to the placement of permanent pavement, all sewer mains shall be cleaned and mandrelled to verify that the pipeline is free from obstructions (deflections, joint offsets, lateral pipe intrusions, etc.). A rigid mandrel, with a circular cross section having a diameter of at least 95 percent of the specified inside pipe diameter, shall be pulled through the pipe by hand. The minimum length of the circular portion of the mandrel shall be equal to the nominal diameter of the pipe. Obstructions encountered by the mandrel shall be repaired and the pipeline section retested.

1. Labor: All labor and equipment necessary to assist the District in conducting this inspection shall be furnished by the Contractor.
2. Pull Line: A 1/4-inch diameter nylon line shall be pulled from manhole to manhole to be left for use by the District in conducting the CCTV inspection.
3. Notification: Requests for sewer line inspection shall be made to the District Representative a minimum of two working days in advance of the requested inspection date.

L. Leakage and Infiltration Test

The pipe, manholes, and other appurtenances shall be tested for leakage and infiltration in accordance with Section 15043, Leakage and Infiltration Testing.

M. Closed-Circuit Television Inspection

1. General: In addition to the regular leakage and infiltration test, all new sewer lines shall be inspected using closed-circuit television (CCTV) equipment. The inspection shall be conducted after all utilities have been installed and prior to paving. The inspection shall be conducted by District staff using District furnished camera equipment at no cost to the Contractor for the initial inspection. Re-inspection shall be conducted by the District, the cost of which shall be the Contractor's responsibility.

2. Labor: All labor and equipment necessary to assist the District in conducting this inspection shall be furnished by the Contractor.
3. Notification: Requests for sewer line inspection shall be made to the District Representative a minimum of two working days in advance of the requested inspection date.
4. Repair of Defects: Even though the sewer line may have successfully passed the leakage and infiltration tests, any defects in the line shall be repaired to the satisfaction of the District. Following repair, mandrel testing, and CCTV inspection shall again be conducted for the repaired pipeline section and these re-inspection costs shall be the sole responsibility of the contractor.

N. Final Inspection

After paving has been completed and all manholes raised to grade (where required), a final visual inspection shall be made. The necessary labor shall be furnished to assist the District Representative in making the final inspection. Additional balling may be required if the lines are dirty, even though lines were previously balled. The Contractor shall furnish a responsible person or supervisor for the final inspection to remove manhole covers and to note any corrections required by the District Representative in order to obtain final approval. Final District inspection shall be requested through the District Representative by giving at least one day advance notice.

END OF SECTION

SECTION 02710: VITRIFIED CLAY PIPE FOR GRAVITY SEWERS

PART 1 - GENERAL

A. Description

This section describes materials, testing, and installation of vitrified clay pipe (VCP) and fittings for sanitary sewers. Unless noted otherwise on the plans, VCP may be used for pipe sizes shown in the pipe schedule located in Section 02701, Installation of Gravity Sewer Pipelines.

B. Related Work Specified Elsewhere

1. Trenching, Backfilling and Compacting: 02223
2. Installation of Gravity Sewer Pipelines: 02701
3. Concrete: 03300
4. Precast Concrete Manholes and Bases: 03461

C. Submittals

1. Shop drawings shall be submitted in accordance with the General Provisions and the following.
2. Provide certificates of compliance with all standards referenced in this section to the District.
3. Provide copies of the manufacturer's required tests to the following conducted on project pipe:
 - a. Crushing test.
 - b. Record of retests and rejections.

D. Inverted Siphons

Inverted siphons, where not shown on the plans, will be allowed only at locations approved by the District.

E. Measurement and Payment

1. Payment for work in this section shall be in accordance with the General Provisions and the following.

2. Payment shall be by the linear foot for each diameter and for each pipe strength designation measured horizontally over the pipe centerline, exclusive of the distance between the inside faces of each structure, manhole or other similar connecting structure. Unless otherwise specified herein, no additional payment shall be made for curved or radius pipe. Such pipe shall be measured and paid for in the same manner as described above for straight pipe.

PART 2 - MATERIALS

A. Vitrified Clay Pipe

1. General: All VCP and fittings shall be extra strength and shall comply with ASTM C700. Pipe and fittings shall be of the best quality; vitrified; homogenous in structure; thoroughly burned through their entire thickness; impervious to moisture; sound; and free from cracks, checks, blister, broken extremities, or other imperfections. Pipe ends shall be square with the longitudinal axis, and sockets shall be true, circular, and concentric with the barrel of the pipe. The thickness of the shell, the depth of the socket, and the dimension of the annular space shall be within the limits of permissible variation to dimension standards of the specifications of ASTM C700, for the size of pipe indicated on the plans.
2. Pipe Marking: All pipe or fittings shall be clearly marked with the name of the manufacturer or with a trademark and with the size and strength of the pipe as shown on the plans and as herein specified.
3. Testing: Before being used in any work under these specifications, pipe shall be subjected to and shall meet the requirements of the following hydrostatic pressure test and loading test; these tests shall be witnessed by a reputable testing laboratory approved by the District. Pipe selected for testing shall be delivered to the place and at the time designated by the testing laboratory. All costs of furnishing, transporting, and handling the pipe for testing and conducting the tests shall be borne by the Contractor.

Where specifically approved by District, a certified statement from the pipe manufacturer, in lieu of witnessing by a testing laboratory may be furnished stating that all prescribed tests have been made and the pipe to be used on the project has met all requirements of the specifications.

The testing laboratory shall select, at random, for testing as herein specified, no less than 1% of the number of pipe sections in each size of pipe furnished.

The specimens selected for testing shall be sound pipe having dimensions consistent with these specifications. The lot or lots from which the tests samples are taken shall be sufficient to fill the entire order for that size of pipe used in the work under the contract and, if they pass the tests, shall be so designated and marked.

All pipe shall be subject to inspection at the factory, trench, or other point of delivery by the District Representative. The purpose of the inspection shall be to cull and reject any pipe that, independent of the physical tests herein specified, fails to conform to the requirements of these specifications or that may have been damaged during transportation or in subsequent handling.

In lieu of the standard ASTM absorption test, the ASTM C301 hydrostatic pressure test shall be substituted. The hydrostatic pressure test shall precede the loading test by not less than one hour or more than three hours and shall be applied to all the specimens received for test in each size of pipe.

The loading test shall be the 3-edge bearing test. The loading tests shall conform to the applicable provisions of ASTM C301 and shall be applied to all specimens selected for testing, except that loading to test ultimate strength will not be required.

If all of the minimum designated percentage or number of the specimens tested meet the requirements of the test, then all of the pipe in the lot, shipment, or delivery corresponding to the sizes and classes so tested shall be considered as complying with the test. If, however, 10% or more of the specimens tested fail to meet the requirements of the test or if more than one specimen fails to meet the requirements of the test when the number to be tested is less than ten, then a second selection of pipe shall be made for that test. The number of specimens to be tested in the second selection of pipe shall be five for each specimen of the first selection that failed to meet the requirements.

If 90% or more of the specimens tested, including those first tested, meet the requirements of the test, all the pipe in the lot, shipment, or delivery corresponding to the sizes and classes so tested shall be considered as complying with that test, otherwise all pipe of these sizes and classes shall be rejected.

4. Causes for Rejection: The following imperfections in a pipe or special fitting shall be considered injurious and cause for rejection without consideration of the test results specified above.
 - a. A single crack in the barrel of the pipe will cause rejection.
 - b. Surface imperfections, such as lumps, blisters, pits or flakes, on the interior surface of a pipe or fitting shall cause rejection.
 - c. When the bore or socket of the pipe varies from a true circle more than 3% of its nominal diameter, it shall be rejected.
 - d. The pipe or fitting shall be rejected if it is designated to be straight and it deviates from a straight line more than 1/16-inch per linear foot. The deviation shall be measured from a straight edge at a point midway between the ends of the pipe.

- e. A joint of pipe with a piece broken from either the socket or spigot end shall be rejected.
 - f. Pipe joints that have tramp clays, grog or other foreign matter flushed permanently to the exterior or interior surface of the pipe or fittings shall be rejected.
5. Joints: Unless otherwise specified, all VCP pipe joints shall be of the bell and spigot compression type, complying with ASTM C425. Joints shall be "Speed Seal" manufactured by Gladding McBean, or polyurethane compression joints manufactured by Mission Clay Products. The compression joint on the spigot and bell ends of the pipe shall be factory made of plastisol, polyurethane elastomer, or other approved resilient element bonded onto the outside of the spigot and the inside of the bell to the pipe and molded and cured to a uniform hardness and compressibility to form a tight compression coupling when assembled.

Where pipes from different manufacturers are to be joined together, an adapter pipe with the proper matching joint on each end for the respective manufacturer shall be used. Hot poured joints or concrete encasement of plain end joints shall not be permitted.

6. Branches: Branches of the type shown on the plans shall be furnished with connections of the sizes specified and shall be securely and completely fastened to the barrel of the pipe in the process of manufacture. Tee branches shall have their axis perpendicular to the longitudinal axis of the pipe. Wye branches shall have their axis approximately 45 degrees (unless otherwise specified on the plans) to the longitudinal axis of the pipe, measured from the socket end. All branches shall terminate in sockets and the barrel of the branch shall be of sufficient length to permit making a proper joint.
7. Stoppers: The stoppers for all pipes 8-inches in diameter and smaller, in which a sealing component for a flexible compression-type joint is cast, shall be neoprene, polyethylene, or polyurethane. Stoppers in all other cases shall be discs of the same material as the pipe, equal in diameter to the outside of the pipe barrel, and made and installed as approved by the District Representative.

Neoprene stoppers shall be manufactured from a compound containing not less than 50 percent neoprene by volume, which shall be the sole elastomer. Stoppers shall not be adversely affected when exposed to the chemical and bacteriological environments normally found in wastewater sewers. Neoprene Stoppers shall be of the type manufactured by Mission Clay Products or Gladding McBean.

When installed and braced in place in branch spurs, stoppers shall withstand a hydrostatic pressure test of 10 psi with no leakage. When unbraced, stoppers shall remain in place when subject to a maximum air pressure test of 5 psi.

8. Manufacturers: Vitrified clay pipe shall be manufactured by Gladding McBean, Pacific Clay Products, Mission Clay Products.

B. Precast Concrete Manholes

Precast concrete manholes shall conform with Section 03461, Precast Concrete Manholes and Bases.

PART 3 - EXECUTION

A. Related Installation Specification

VCP pipe shall be installed in accordance with the requirements of Section 02701, Installation of Gravity Sewer Pipelines.

B. Horizontal Curve Installation

Unless noted otherwise on the plans or specifications, horizontal curves using Vitrified Clay Pipe shall not be less than the following radii:

Pipe Size	Length of Pipe Joint						
	10'	8'	6'	5'	4'	3'	2'
6" - 12"	---	---	---	150'	125'	85'	57'
15" - 24"	320'	256'	192'	160'	128'	96'	---
27" - 36"	480'	384'	288'	240'	192'	---	---
39" - 48"	640'	512'	384'	320'	256'	---	---

END OF SECTION

SECTION 02715: PVC PIPE AND FITTINGS FOR GRAVITY SEWERS

PART 1 - GENERAL

A. Description

This section includes materials, testing, and installation of polyvinyl chloride (PVC) gravity sewer pipe and fittings. Unless noted otherwise on the plans, PVC may be used for pipe sizes shown in the pipe schedule located in Section 02701, Installation of Gravity Sewer Pipelines.

B. Related Work Specified Elsewhere

1. Trenching, Backfilling and Compacting: 02223
2. Jacked Casing: 02315
3. Installation of Gravity Sewer Pipelines: 02701
4. Vitrified Clay Pipe for Gravity Sewers: 02710
5. Concrete: 03300
6. Precast Concrete Manholes and Bases: 03461
7. PVC Pressure Pipe and Fittings: 15064

C. Submittals

1. Shop drawings shall be submitted in accordance with the General Provisions and as specified herein.
2. Provide materials list showing material of pipe and fittings with ASTM references and grade.
3. Provide certificates of compliance with all standards referenced in this section.

D. Application

1. Alternative to VCP: Unplasticized PVC plastic pipe may be used as an alternate to VCP on residential tract sewers and residential house laterals only.
2. Limitations: Use of PVC for main line sewers on industrial, commercial, and medical installations will be permitted only where approved, in advance, by the District.

3. Pipe Material Transitions: Sewer pipe material shall remain constant between manholes. Pipe material transitions shall be made only at manholes.

E. Sewer Force Mains

PVC sewer force mains shall be constructed in accordance with the requirements of Section 15064, PVC Pressure Pipe and Fittings. Pipe fittings shall be lined with or made from materials that are corrosion resistant.

F. Delivery, Storage, and Handling

1. Care shall be exercised in handling, loading, unloading, and storing PVC pipe and fittings to avoid distortion, scratches, gouges, dents, and scuffing of the ends.
2. All plastic pipe and fittings shall be stored under cover in a flat, horizontal position, and protected from the sun and the elements until ready for installation.
3. Plastic pipe shall be transported in a vehicle having a bed long enough to provide support for the full length of the pipe.
4. Any length of pipe or fitting that has been damaged or distorted shall be replaced.
5. When work is not in progress, open ends of pipe and fittings shall be securely closed so that no water, earth, or other substances will enter the pipe or fittings.

PART 2 - MATERIALS

A. Pipe and Fittings

1. ASTM Requirements: Pipe, fittings, couplings, and joints shall be in conformance with the size, material and performance requirements of ASTM D3034, SDR 35, DR 14 and DR 18 and shall have gasketed joints.

Pipe shall be made of PVC plastic having a cell classification of 12454 as defined in ASTM D1784. All pipe shall be of solid wall construction with smooth interior and exterior surfaces.

Fittings shall be made of PVC plastic having a cell classification of 12454.
2. Manufacturer's Testing Certification: During production of the pipe, the manufacturer shall perform the specified tests for each pipe marking. A certification by the manufacturer indicating compliance with specification requirements shall be delivered with the pipe. The certification shall include the test result data.
3. Pipe Marking: All pipe, fittings, and couplings shall be clearly marked at an interval not to exceed 5-feet as follows:

- a. Nominal pipe diameter.
- b. PVC cell classification.
- c. Company, plant, shift, ASTM, SDR, and date designation.
- d. Service designation or legend.

For fittings and couplings, the SDR designation is not required. All pipe shall have a home mark on the spigot end to indicate proper penetration when the joint is made. Fittings shall be marked with raised molding markings on two sides (diametrically opposite from each other) showing the manufacturer's identification information.

4. Additional Pipe Tests Following Delivery: When pipe is delivered to the jobsite, the District Representative may require additional testing to determine conformance with the requirements of pipe flattening, impact resistance, pipe stiffness, and extrusion quality.

When testing is required, one test pipe shall be selected at random by the District Representative from each 1,200 feet or fraction thereof of each size of pipe delivered to the jobsite, but not less than one test pipe per lot. A lot shall be defined as pipe having the same identification marking. The length of specimen for each selected pipe shall be a minimum of 8-feet.

5. Pipe Retest: Pipe which is not installed within 120 days of the latest test shall not be used without prior approval from the District Representative.
6. Fitting and Coupling End Configurations: The socket and spigot configurations for fittings and couplings shall be compatible with those used for the pipe.
7. Pipe Manufacturers: Pipe shall be as manufactured by Diamond Plastics Corporation, J-M Manufacturing Company, Inc. and PW Eagle, Inc. (dba JM Eagle™), Vinyltech Corporation, or Westlake Pipe & Fittings.
8. Fittings Manufacturers: Fittings shall be as manufactured by GPK Products, Inc., Harco Fittings, Inc. (dba Harrington Corporation and HARCO), J-M Manufacturing Company, Inc. and PW Eagle, Inc. (dba JM Eagle™), Multi Fittings Corporation, Plastic Trends, Inc., or Tigre PVC Fittings.

B. Gaskets for PVC Pipe

1. General: Unless otherwise specified, gaskets shall be manufactured from a synthetic elastomer, and shall be extruded or molded and cured in such a

manner as to be dense, homogeneous and of smooth surface, free of pitting, blisters, porosity, and other imperfections. The compound shall contain not less than 50 percent by volume of first-grade synthetic rubber. The remainder of the compound shall consist of pulverized fillers free of rubber substitutes, reclaimed rubber, and deleterious substances.

The tolerance for any diameter measured at any cross section shall be $\pm 1/32$ -inch (.8mm).

2. **Gasket Material Requirements:** When required by the District Representative, the Contractor shall furnish test samples of gaskets from each batch used in the work.

- a. Gasket material shall meet the following requirements:

Property	Value	ASTM Test Method
Tensile strength (min. psi)	2,000	D412
Elongation at break (% min.)	350	D412
Shore durometer, Type A(Pipe manufacturer shall select value suitable for type of joint)	40 to 65*	D2240
Compression set (constant deflection) max. % of original deflection	16	D395 Method B
Tensile strength after oven aging (96 hours, 158°F [70°C]) % of tensile strength before aging	80	D573
Increase in Shore durometer hardness after oven aging. Maximum increase over original Shore durometer	10	D2240
Physical requirements after exposure to ozone concentration (150 pphm. 70 hours, 140° F [40°C], 20% strain)	No Cracks	D1149

*Applies only to the sealing component of the gasket.

3. **Splices:** No more than one splice will be permitted in a gasket. A splice shall be made by applying a suitable cement to the ends and vulcanizing the splice in a full mold. The splice shall show no separation when subjected to the following tests:
 - a. **Elongation Test:** The part of the gasket which includes the splice shall withstand 100% elongation with no visible separation of the splice. While in the stretched position, the gasket shall be rotated in the spliced area minimum of 180 degrees in each direction in order to inspect for separation.
 - b. **Bend Test:** The portion of the unstretched gasket containing the splice shall be wrapped a minimum of 180 degrees and a maximum of 270 degrees around a rod of a diameter equal to the cross section diameter of the gasket.

PART 3 - EXECUTION

A. Related Installation Specification

PVC gravity sewer pipe shall be installed in accordance with the applicable requirements of Section 02701, Installation of Gravity Sewer Pipelines and Section 02710, Vitrified Clay Pipe for Gravity Sewers.

B. Allowable Horizontal Curve Construction

Unless noted otherwise on the plans or specifications, horizontal curves using PVC pipe shall not have radii less than the following:

Pipe Size (inches)	Minimum Radius (feet)
6	210
8	280
10	350
12	420

END OF SECTION

SECTION 03100: CONCRETE FORMWORK

PART 1 - GENERAL

A. Description

This section describes materials and installation of concrete forms.

B. Related Specification Sections

1. Concrete Reinforcement: 03201.
2. Concrete Joints and Waterstops: 03260.
3. Concrete: 03300.
4. Concrete Finishing, Curing, and Waterproofing: 03345.
5. Painting and Coating: 09900.

C. Submittals

1. Shop drawings shall be submitted in accordance with the General Provisions and the following.
2. Submit manufacturer's literature for form ties, spreaders, corner form, form coating, and bond breakers.

PART 2 - MATERIALS

A. Form Construction and Design

1. General: Forms shall be designed according to the applicable portions of ACI 347, "Recommended Practice for Concrete Formwork," and all applicable regulations and codes. All concrete shall be formed unless specified otherwise.
2. Observation Points: Form windows or stage forms shall be provided to allow observation at all times before concrete is poured. Formwork and placement design shall be such as to limit free fall of concrete to 4 feet.
3. Notification: The District's Representative shall be notified a minimum of one day prior to concrete placement.

B. Classes of Forms

1. Class I Forms: Smooth-surface plywood 3/4 inch minimum thickness shall be used for straight surfaces and 1/2 inch minimum thickness for curved surfaces.
2. Class II Forms: Forms shall be made of plywood in good condition, metal, or smooth-planed boards free from large or loose knots with tongue and groove or ship lap joints. Forms shall be oiled.
3. Application: Class II forms shall be used for exterior concrete surfaces which are 1 foot or more below finished grade. Class I forms shall be used for all other surfaces.

C. Form Material

1. General: Forms shall be made of plywood, lumber, or steel of sufficient strength and surface smoothness to produce the specified finish. Joints, gaps, and apertures in forms shall be taped, gasketed, plugged and/or caulked so that the joint will remain watertight and withstand placing pressures without bulging outward or creating surface irregularities.
2. Lumber: Lumber used in form construction shall be standard grade Douglas fir, S4S Standard Grading and Dressing Rules No. 16, West Coast Lumber Inspection Bureau. Boards in contact with concrete shall be 6 inches or more in width.
3. Plywood: Plywood used in form construction shall be Grade B-B, Class 1 plyform, mill-oiled, and sanded on both sides in conformance with U.S. Product Standard PS-1.

D. Form Ties

1. General: Form ties shall be located on exposed surfaces in a uniform pattern or as indicated on the drawings. Form ties shall be constructed so that the tie remains embedded in the wall except for a removable portion at each end. Form ties shall have conical or spherical type inserts with a maximum diameter of 1 inch. Form ties shall be constructed so that no metal is within 1 inch of the concrete surface when the forms, inserts, and tie ends are removed. Wire ties shall not be used. Ties shall withstand all pressures and limit deflection of forms to acceptable limits.
2. Flat Bar Ties: Flat bar ties for panel forms shall have plastic or rubber inserts having a minimum depth of 1 inch and sufficient dimensions to permit patching of the tie hole.
3. Ties with Integral Waterstops: Ties for water-holding structures or dry structures with access, such as basement access shafts or pipe galleries, that are below finished grade, shall have an integral steel waterstop that is tightly and continuously welded to the tie. The waterstop shall be at least two times larger in area than the tie cross-sectional area and shall be oriented perpendicular to the tie and symmetrical about the center of the tie. Ties shall be constructed to provide a positive means of preventing rotation or disturbance of the center portion of the tie during removal of the ends.

4. Tapered Form Ties: Tapered form ties shall be tapered through-bolts at least 1 inch in diameter at smallest end, or through-bolts that utilize a removable tapered sleeve of the same minimum size.

E. Bond Breaker

Bond breaker shall be a nonstaining type which will provide a positive bond prevention, such as Williams Tilt-Up Compound, as manufactured by Williams Distributors, Inc., Seattle, Washington; or Silco seal 77, as manufactured by SCA Construction Supply Division, Superior Concrete Accessories, Franklin Park, Illinois.

F. Form Release Agent

Form release agent shall effectively prevent absorption of moisture and prevent bond with the concrete. Agent shall be nonstaining and nontoxic after 30 days.

For steel forms, release agent shall prevent discoloration of the concrete due to rust.

PART 3 - EXECUTION

A. Form Tolerances

1. Rejected Work: Failure of the forms to produce the specified concrete surface and surface tolerance shall be grounds for rejection of the concrete work. Rejected work shall be repaired or replaced at no additional cost to the District.
2. Allowable Tolerances: The following table indicates tolerances or allowable variations from dimensions or positions of structural concrete work:

<u>Item</u>	<u>Maximum Tolerance</u>
Sleeves and inserts.....	1/4"-1/4"
Projected ends of anchors	1/4"-0.0"
Anchor bolt setting	1/4"-1/4"
Finished concrete, all locations	1/4" ...-1/4" in, 10 feet
Finished concrete, total length.....	+1"

The planes or axes from which the above tolerances are to be measured shall be as follows:

Sleeves and inserts: Centerline of sleeve or insert.

Projected ends of anchors: Plane perpendicular to the end of the anchor as located on the drawings.

Anchor bolt setting: Centerline of anchor bolt.

Finish concrete: The concrete surface as located on the drawings.

Where equipment is to be installed, the manufacturer's tolerances shall be complied with if more stringent than the above.

B. Form Surface Preparation

1. Cleaning: Form surfaces to be in contact with the concrete shall be cleaned of all previous concrete, dirt, and other surface contaminants prior to preparation by the applicable method below.
2. Release Agent: Wood surfaces and steel surfaces in contact with the concrete shall be coated with a release agent prior to form installation.

C. Chamfers

1. General Dimensions: 3/4-inch bevels shall be formed at concrete edges except those on top of walls and elevated slabs and beams. Edges at top of walls, slabs, and beams shall be rounded to a 3/4-inch radius.
2. Exterior Corners: Exterior corners in concrete members shall be provided with 3/4-inch chamfers. Reentrant corners in concrete members shall not have fillets, unless otherwise shown on the drawings.

D. Form Placement

1. General: Forms shall be provided with adequate means for holding adjacent edges and ends of panels and sections tightly together and in accurate alignment so as to prevent the formation of ridges, fins, offsets, or similar surface defects in the finished concrete. The forms shall be tight and braced in order to prevent movement and the loss of mortar and fines during placing and vibration of the concrete.
2. Inspection Openings: Cleanout and inspection openings shall be provided at the bottom of each lift of forms. There shall be one 12-inch-wide by 18-inch-high opening every 7 feet at the bottom of each lift of forms.
3. Allowable Embedment of Form Tie in Concrete: No part of any form tying device other than metal shall be embedded in the concrete.
4. Taper Tie Orientation: The large end of taper ties shall be located on the "wet" side of the wall.
5. Prevention of Spalling: Only form or form-tying methods which do not cause spalling of the concrete upon form stripping or tie removal shall be allowed.
6. Non-formed Concrete: Surfaces of concrete members shall be formed except where placement of the concrete against the ground is shown on the drawings. The dimensions of concrete members shown on the drawings shall apply to formed surfaces, except where otherwise indicated. At least 2 inches of concrete shall be added where concrete is placed against trimmed undisturbed ground in lieu of forms. Placement of concrete against the ground shall be limited to footings and only where the character of the ground is such that it can be trimmed to the required lines and will stand securely without caving or sloughing.

E. Form Reuse

Only forms which maintain a uniform surface texture on exposed concrete surfaces shall be used. Light sanding shall be applied between uses to obtain uniform texture. Unused tie rod holes with corks, shaved flush, and sandpapered on the concrete surface side. Other than filling tie rod holes, forms shall not be patched except in the case of Class II forms. Metal patching discs shall not be used on Class I forms.

F. Form Removal & Timing

1. Protection of Concrete Surfaces: Means shall be provided for removing forms without injury to the surface of the finished concrete.
2. Form Placement Duration: Forms and shoring for elevated structural slabs or beams shall remain in place until the concrete has reached a compressive strength equal to the specified 28-day compressive strength as determined by test cylinders. Supports shall not be removed and reshored. The following table indicates the minimum allowable time after the last cast concrete is placed before forms, shoring, or wall bracing shall be removed:

Sides of footings and encasements	24 hours
Walls not supporting load	48 hours
Vertical sides of beams, girders, and similar members	48 hours
Slabs, beams, and girders	10 days (forms only)
Shoring for slab, beams, and girders	Until concrete strength reaches specified 28-day strength
Wall bracing	Until top or roof slab concrete reaches 2,500 psi

3. Form Placement Duration in Cold Weather: Forms shall not be removed from concrete which has been placed with outside air temperature below 50° F without first determining if the concrete has properly set without regard for time. Heavy loading shall not be applied to green concrete. Immediately after forms are removed, the surface of the concrete shall be carefully examined and any irregularities in the surface shall be repaired and finished as specified.

G. Formed Openings

Openings shall be of sufficient size to permit final alignment of the items within it without deflection or offsets of any kind and to allow space for packing where the items pass through the wall to ensure watertightness around openings so formed. Openings shall be provided with continuous keyways with waterstops where required, and a slight

flare to facilitate grouting and the escape of entrained air during grouting. Formed openings shall be provided with reinforcement as indicated in the typical structural details. Reinforcing shall be at least 2 inches clear from the opening.

H. Embedded Items

Anchor bolts and other embedded items shall be set accurately and held securely in position in the forms until the concrete is placed and set. All special castings, channels, or other metal parts that are to be embedded in the concrete shall be checked prior to and again after concreting. All nailing blocks, plugs, and strips necessary for the attachment of trim, finish, and similar work shall be checked prior to concreting.

I. Pipes and Wall Spools Cast in Concrete

1. Fittings Cast in Formed Concrete Structures: Wall spools, wall flanges, and wall anchors shall be installed before placing concrete. Wall spools or anchors shall not be welded, tied, or otherwise connected to the reinforcing steel.
2. Pipe Encasement: Pipe and fabricated fittings to be encased in concrete shall be supported on concrete piers or pedestals. Concrete supports shall be carried to firm foundations so that no settlement occurs during construction.

END OF SECTION

SECTION 03201: CONCRETE REINFORCEMENT

PART 1 - GENERAL

A. Description

This section describes materials, testing, and installation of reinforcing steel for concrete.

B. Related Work Specified Elsewhere

1. Concrete Formwork: 03100.
2. Concrete: 03300.

C. Submittals

1. Shop drawings shall be submitted in accordance with the General Provisions and the following.
2. Submit mill test certificates identifying chemical and physical analyses of each load of reinforcing steel delivered. If mill test reports are unavailable and the quantity of steel for a structure exceeds 5 tons, then provide a laboratory test to prove yield strength and bending.
3. Submit bending lists and placing drawings for all reinforcing steel. Each bending list submitted shall be complete, including corner bars as required. Furnishing such lists shall not be construed that the lists will be reviewed for accuracy. The Contractor shall be wholly and completely responsible for the accuracy of the lists and for furnishing and placing reinforcing steel in accordance with the details shown on the plans and as may be specified elsewhere in the contract documents.

PART 2 - MATERIALS

A. Reinforcing Steel

1. General Requirements: Reinforcing steel shall be new material conforming to ASTM A 615, Grade 60, and shall be fabricated in accordance with the current edition of the Manual of Standard Practice, published by the Concrete Reinforcing Steel Institute.
 - a. Reinforcing steel shall be bent while cold.
 - b. Reinforcing steel which is to be welded, shall conform to ASTM A 706, Grade 60.
2. Delivery: Reinforcing steel shall be delivered to the site bundled and with identifying tags.

B. Welded Wire Fabric

Welded wire fabric shall conform to ASTM A 1064.

C. Tie Wire

Tie wire shall be 16 gage minimum, black, soft annealed.

D. Bar Supports

Bar supports in beams and slabs exposed to view after form stripping shall be non-metallic and of sufficient strength to properly secure the reinforcement bars during the placement of concrete. Concrete supports shall be used for reinforcing in concrete placed on grade.

PART 3 - EXECUTION

A. Placing

1. General: Reinforcing steel shall be placed in accordance with ACI and the current edition of Recommended Practice for Placing Reinforcing Bars, published by the Concrete Reinforcing Steel Institute.
2. Cleaning: Reinforcing steel, before being positioned, shall be free from loose mill and rust scale and from any coatings that may destroy or reduce the bond. Where there is delay in depositing concrete, reinforcement steel shall be cleaned by abrasive sandblasting to remove mortar, oil, dirt, excessive mill scale, scabby rust, and coatings of any character that would destroy or reduce the bonding capability.
3. Bending: Reinforcing steel shall not be straightened or reshaped in a manner that will injure the material.
 - a. Bars with bends not shown on the drawings shall not be used.
 - b. Bars that are partially embedded in concrete shall not be bent.
4. Reinforcing Steel Positioning: Reinforcing steel shall be positioned in accordance with the drawings and secured by using annealed wire ties or clips at inter-sections and support by concrete or metal supports, spacers, or metal hangers. Metal clips or supports shall not come in contact with the forms. Tie wires shall be bent away from the forms in order to provide the specified concrete coverage. Bars in addition to those shown on the drawings, which may be found necessary or desirable for the purpose of securing reinforcement in position, may be provided, at no additional expense to the District.
5. Clearance and Cover: Reinforcing steel shall be placed a minimum of 2 inches clear of any metal pipe or fittings. Unless otherwise indicated on the Plans, reinforcement shall be placed so as to provide the thickness of protective concrete covering as indicated on the Typical Details. If not indicated on the Plans or Standard Drawings, protective covering shall be in accordance with ACI 318.

B. Splices

Unless otherwise shown, splices in adjacent horizontal bars shall be staggered 48 bar diameters.

END OF SECTION

SECTION 03260: CONCRETE JOINTS AND WATERSTOPS

PART 1 - GENERAL

A. Description

This section describes materials, testing, and installation of construction and expansion joints, PVC waterstops, premolded joint filler, joint sealant, and bond breaker tape.

B. Related Work Specified Elsewhere

1. Concrete Formwork: 03100
2. Concrete Reinforcement: 03201
3. Concrete: 03300
4. Concrete Finishing, Curing, and Waterproofing: 03345

C. Submittals

1. Shop drawings shall be submitted in accordance with the General Provisions and as specified herein.
2. Submit manufacturer's literature, catalog data, and statement of compliance with referenced standards and specifications.
3. Submit material samples of PVC waterstops.

PART 2 - MATERIALS

A. PVC Waterstop

1. Material: Waterstops shall be extruded from a PVC compound and shall be flat-strip ribbed type as manufactured by B. F. Goodrich Company, or Kirkhill Rubber Company. Waterstop shall comply with Corps of Engineers Specification CRD-C-572. The basic resin of the material shall be a PVC resin plastic, containing nonmigrating-type plasticizers, and shall not be appreciably affected by alkali, acids, or saltwater. All material shall be virgin material. The use of reworked PVC or other substitute will not be permitted.
2. Fittings: Waterstops shall be supplied and installed in accordance with the dimensions shown on the drawings, and shall be made continuous by means of factory made fittings.

B. Joint Sealant for Concrete Structures

The joint sealant shall be a two-part, gray, nonstaining, nonsagging, polyurethane sealant, which cures at ambient temperature to a firm, flexible, tear-resistant rubber. The sealer shall be resilient and have excellent recovery characteristics after extended periods of compression or elongation. Sealant shall be Sika 2C.

C. Neoprene Rods for Precast Slab Joints

Neoprene rods shall be the diameter shown on the plans and shall be 50 durometer.

D. Premolded Joint Filler

Joint filler shall be preformed, nonextruded type, constructed of closed-cell neoprene conforming to ASTM D 1752, Type I, as manufactured by W. R. Grace Company of Cambridge, Massachusetts, or W. R. Meadows, Inc., Elgin, Illinois.

E. Neoprene Bearing Pads

Neoprene bearing pads for precast concrete slabs shall be of the size, thickness, and length shown on the plans and shall be 60 durometer.

F. Bond Breaker Tape

Bond breaker tape shall be an adhesive backed glazed butyl or polyethylene, which adheres to the premolded joint material or concrete surface. The tape shall be the same width as the joint. The tape shall be compatible with the sealant.

PART 3 - EXECUTION

A. PVC Waterstops

1. Installation: Waterstops shall be installed in construction and expansion joints in hydraulic structures or where shown on the drawings. Forms for construction joints shall be constructed in such a manner as to prevent damage to waterstops. Waterstops shall be held securely in position in the construction joints by wire ties, continuous bars, and rings as indicated. Waterstops shall be properly heat spliced at ends and intersections to ensure continuity.
2. Field Splices: Field splices shall be made with a thermostatically controlled heating iron in conformance with the manufacturer's recommendations. At least 10 minutes shall be allowed before pulling or straining the new splice in any way. The finished splices shall provide a cross section that is dense and free of porosity with tensile strength of not less than 80% of the unspliced materials.

B. Construction Joints

1. General: Construction joints shall be provided where shown on the drawings. In case of emergency, additional construction joints shall be placed. An interval of 45 minutes between two consecutive batches of concrete shall constitute cause for an emergency construction joint. At the District's sole discretion, the slab or concrete placement may be rejected and be removed entirely. The costs related to such removal and replacement shall be born by the contractor. All emergency construction joints are subject to final approval by the District.
2. Construction Joint Keyways: Construction joints shall be keyed, if indicated on the drawings. Keyways shall be formed by beveled strips or boards placed at right angles to the direction of shear. Except where otherwise shown on the drawings or specified, keyways shall be at least 1-1/2 inches in depth over at least 25% of the area of the section.

3. Reinforcing Dowels: When an emergency joint is necessary, the joint shall be keyed and reinforcing dowels shall be furnished and placed across the joint. These dowels shall be embedded 60 bar diameters into each side of the joint. Size and number of dowels shall match reinforcing in the member. Furnishing and placing such reinforcing steel shall be done at no additional costs to the District.
4. Joint Preparation for Adjacent Pour: After the pour has been completed to the construction joint and the concrete has hardened, the entire surface of the joint shall be thoroughly cleaned of surface laitance, loose or defective concrete, and foreign material, and clean aggregate shall be exposed by sandblasting the surface of construction joints before placing the new concrete. Horizontal construction joints shall be covered with mortar. Mortar shall be spread uniformly and worked thoroughly into all irregularities of the surface. The mortar shall be flowable and shall consist of sand, water, and a minimum of 12 sacks of cement per cubic yard. A positive measuring device, such as a bucket, or other device shall be provided that will contain only enough mortar for depositing in one place in the wall or column to ensure that portion of the form does not receive too much mortar. Mortar shall not be deposited from pump hoses or large concrete buckets unless inspection windows close to the joint are available to allow visual measurement of mortar thickness and means for mortar removal is available for removal of any excess. The water-cement ratio of the mortar in place shall not exceed that of the concrete to be placed upon it. The consistency of the mortar shall be suitable for placing and working.

C. Installation of Premolded Joint Filler

Premolded joint filler shall be installed in joints accurately as shown. Joint filler shall be attached to concrete with a bonding agent recommended by the joint sealant and joint filler manufacturer for compatibility.

D. Installation of Joint Sealants

1. Joint Cavity Preparation: Immediately before installing the joint sealant, the joint cavity shall be cleaned by sandblasting or power wire brushing. Bond breaker tape shall be installed per manufacturer's instructions.
2. Sealant Application: After the joints have been prepared as described above, the joint sealant shall be applied. Primer, if required, and joint sealant shall be applied only with the equipment and methods recommended by the joint sealant manufacturer. Application criteria for the sealant materials, such as temperature and moisture requirements and primer cure time, shall be in accordance with the recommendations of the sealant manufacturer.
3. Finishing: Masking tape shall be applied along the edges of the exposed surface of the exposed joints. Joints shall be troweled smooth with a tuck pointing tool wiped with a solvent as recommended by the sealant manufacturer.
4. Cleanup: After the sealant has been applied, masking tape and any sealant spillage shall be removed.

E. Installation of Neoprene Rods in Precast Slab Joints

Neoprene rods shall be forced down to the bottom of the shaped joint prior to placing drypack in the joint.

F. Installation of Neoprene Bearing Pads

Neoprene bearing pads shall be placed in the indicated position on the concrete walls and glued to the wall with suitable adhesive.

END OF SECTION

SECTION 03300: CONCRETE

PART 1 - GENERAL

A. Description

This section describes materials, mixing, and placing of concrete and grout.

B. Related Work Specified Elsewhere

1. Concrete Formwork: 03100
2. Concrete Reinforcement: 03201
3. Concrete Joints and Waterstops: 03260
4. Concrete Finishing, Curing, and Waterproofing: 03345
5. Standard Specifications for Public Works Construction

C. Submittals

1. Shop drawings shall be submitted in accordance with the General Provisions, ACI 318 and as specified herein.
2. Mix design with proof of design by laboratory 7-day and 28-day compressive tests, or test reports of 7-day and 28-day compressive tests of the mix where the same mix was used on two previous projects, shall be submitted in writing for review by the District at least 21 days before placing of any concrete.
3. Certificate that cement used in the concrete complies with ASTM C150 and these specifications shall be submitted.
4. Aggregates: Certificate of compliance with ASTM C33 shall be provided. Weathering region limits of coarse aggregates: severe, moderate, or negligible shall be stated. Basis of determining that potential reactivity is negligible shall be stated.
5. Ready Mix Concrete: Delivery tickets or weighmasters certificate per ASTM C94, including weights of cement and each size aggregate, volume of water in the aggregate, and volume of water added at the plant shall be provided. The volume of water added on the job shall be written on the ticket or certificate.
6. Concrete admixtures: Manufacturer's certificate of compliance with these specifications shall be provided.
7. Epoxy Bonding Compound: Manufacturer's specific instructions for use shall be provided.
8. Nonshrink Grout: Manufacturer's certificate of compliance with these specifications and specific instructions for use shall be provided.

9. Placement Drawings
 - a. Composite concrete placement drawings for each individual placement shall be submitted, indicating location and sizes of pipe sleeves, conduits, inserts, reglets, anchor bolts, openings, recesses, construction joints, expansion joints, and other embedded items. Placement drawings shall be coordinated with drawings. Placement drawings shall show where each mix will be used.
 - b. Each drawing shall show only one placement. Match-lines shall reference adjoining placement drawings, and an index shall be provided on each sheet showing the location of the placement in the overall structure.
 - c. The Contractor shall submit a copy of the sequence of placement in advance of actual placement.

PART 2 - MATERIALS

A. Cement

Cement shall conform to ASTM C150, Type II or Type V. The content of tricalcium aluminate shall not exceed 6% and the content of alkalis shall not exceed 0.6%.

B. Aggregates

Aggregates shall comply with ASTM C33 and shall be free from any substances that will react with the cement alkalis.

C. Water and Ice

Water and ice that is clean and free from objectionable quantities of organic matter, alkali, salts, and any other impurities which might reduce the strength, durability, and quality of the concrete shall be used in the concrete mix.

D. Color Additive

For exterior electrical duct concrete encasements, a color additive shall be used for identification purposes: Color additive shall be "Increte SC Coral Red" as manufactured by Euclid Chemical Company, or coral red "Chromix C-22," as manufactured by L. M. Scofield Company, Los Angeles, California. The color additive shall be added while the concrete is being mixed using the quantity per cubic yard of concrete recommended by the manufacturer for the class of concrete indicated.

E. Concrete Admixtures

1. Air-Entraining Admixture: Concrete may contain an air-entraining admixture which shall conform to ASTM C260, except it shall be nontoxic after 30 days and shall contain no chlorides. Admixture shall be Euclid Chemical Company, Grace Construction Products, Master Builders, or Sika.
2. Water-Reducing Admixture: Concrete may contain a water-reducing admixture which shall conform to ASTM C494, Type A or Type D, except it shall contain no chlorides, shall be nontoxic after 30 days, and shall be compatible with the

air-entraining admixture. The amount of admixture added to the concrete shall be in accordance with the manufacturer's recommendations. Admixture shall be Euclid Chemical Company, Grace Construction Products, Master Builders Pozzolith polymer-type normal setting, or Sika.

3. Admixture Restrictions: Accelerating water-reducing admixtures or any other type of admixture that contains chlorides or other corrosive elements shall not be used in any concrete.
4. High-Early Strength Concrete: Admixtures for high-early strength concrete shall be non-chloride admixtures which meet the requirements of ASTM C494. Acceptable products are Euclid Chemical Company, Grace Construction Products, or Master Builders. Concrete shall reach 2,500 psi compressive strength within eight (8) hours of being placed.

F. Non-shrink Grout

Non-shrink grout shall conform to the Army Corps of Engineers Specification for Nonshrink Grout, ASTM C1107 and CRD-C621, and to these specifications. Use a non gas-liberating type, cement base, premixed product requiring only the addition of water for the required consistency. Grout shall be UPCON High Flow BASF, or Master Flow 713. All components shall be inorganic.

G. Ordinary Type Grout (Dry Pack)

Ordinary type grout shall consist of one part portland cement to two parts sand (100% passing a No. 8 sieve). Sufficient water shall be added to produce damp formable consistency.

H. Epoxy Bonding Compound

Manufacturer's certifications as to suitability of product to meet job requirements with regard to surface, pot life, set time, vertical or horizontal application, and forming restrictions shall be provided. Bonding compound shall be Concesive 1001 LPL as manufactured by Adhesive Engineering Company, San Carlos, California, or Sikadur 32 Hi-Mod LPL as manufactured by Sika Chemical Corporation.

I. Concrete Mix Design

1. General: Concrete mix design shall conform to ASTM C94 and ACI 318, except as modified by these specifications.
2. Cement Substitutes: Fly ash and other cement substitutes shall not be used in the mix.
3. Air Content: Air content as determined by ASTM C231 shall be 4% ±1%.
4. Water-Cement Ratio: Maximum water-cement ratio for Class A concrete shall not exceed 0.44 by weight.

5. Classes: Classes of concrete shall be used as described in the following table:

Class	Type of Work	28-Day Compressive Strength (psi)	Minimum Cement Content (lbs per CY)
A	All curbing, sidewalks, manhole bases, thrust blocks, and structures unless specified elsewhere.	3,250	560 = 6 sack
B	Where shown on plans or IRWD std. drawings	2,500	470 = 5 sack
C	Fill for structure foundations, cradles, supports across pipe trenches, anchors and miscellaneous unreinforced concrete	2,000	376 = 4 sack

6. Slump: Slump shall be measured in accordance with ASTM C 143. Slump shall be as follows:

Slab on grade or heavy sections3 inches maximum wider (in plan view) than 3 feet

Footings, walls, suspended4 inches maximum slabs, beams, and columns

Concrete shall be proportioned and produced to have a maximum slump as shown. A tolerance of up to 1-inch above the indicated maximum shall be allowed for individual batches provided the average for all batches or the most recent 10 batches tested, whichever is fewer, does not exceed the maximum limit. Concrete of lower than usual slump may be used provided it is properly placed and consolidated.

7. Aggregate Size: Aggregate size shall be 1-inch maximum for slabs and sections 8 inches thick and less. Aggregate size shall be 1 1/2-inch maximum for all larger slabs and sections. For manhole bases maximum aggregate size, refer to Section 03461 Precast Concrete Manholes and Bases. Combined aggregate grading shall be as shown in the following table:

Maximum Aggregate Size Percentage Passing by Weight		
Sieve Sizes	1 1/2-inch	1-inch
2"	100	---
1 1/2"	90-100	100
1"	50-86	95-100
3/4"	45-75	77-93
3/8"	38-55	50-70
No. 4	30-45	39-51
No. 8	23-38	31-41
No. 16	17-33	22-32
No. 30	10-22	12-22
No. 50	4-10	3-15
No. 100	1-3	0-5
No. 200	0-2	0-2

8. Pumped Concrete Design Mix: Mix design for pumped concrete shall produce a plastic and workable mix. The percentage of sand in the mix shall be based on the void volume of the coarse aggregate.

J. Workability

1. General: Concrete shall be of such consistency and composition that it can be worked readily into the forms and around the reinforcement without excessive spading and without permitting the materials to segregate or free water to collect on the surface. The proportions shall be adjusted to secure a plastic, cohesive mixture, and one which is within the specified slump range.
2. Aggregate: To avoid unnecessary changes in consistency, aggregate shall be obtained from a source with uniform quality, moisture content, and grading. Materials shall be handled in such a manner that variations in moisture content will not interfere with production of concrete of the specified degree of uniformity and slump.

PART 3 - EXECUTION

A. Site-Mixed Concrete

1. General: Site-mixed concrete shall conform to ACI 304 as modified by these specifications.
2. Batching and Mixing Equipment: A batch-type mixer shall be used that is capable of combining the aggregates, cement, and water within the specified time into a thoroughly mixed and uniform mass and discharging the mixture without segregation. Supporting equipment shall be used that can accurately proportion the cement, the coarse and fine aggregates, the admixtures, and the water which enters the mixing drum. Cement and aggregate shall be proportioned by weight. Each entire batch shall be discharged before recharging. The volume of the mixed materials per batch shall not be allowed to exceed the manufacturer's rated capacity of the mixer.
3. Mixing Time: Mixing time shall be as follows:
 - a. For mixer of a capacity of 1 cubic yard or less, one and one-half minutes after batching is completed.
 - b. For mixers of capacities larger than 1 cubic yard, one and one-half minutes plus one-half minute for each additional 1/2-cubic-yard capacity or fraction thereof in excess of 1 cubic yard.
 - c. The mixer shall revolve at a uniform rate as specified by the manufacturer for the mixing equipment.

B. Ready-Mixed Concrete

1. General: Ready-mixed concrete shall conform to ASTM C94 as modified by these specifications.

2. Haul Time Requirements: The haul time of ready-mixed concrete shall be limited so that the specified slump is attained without the onsite addition of water, which may cause the mix design water-cement ratio to be exceeded. In no case shall the time between the time when the concrete is batched and it is placed exceed 90 minutes. When haul time is excessive, truck-transported, dry-batched concrete shall be used and mixed on the jobsite. Partially hardened concrete shall not be retempered.

C. Placing Concrete

1. General: Concrete placement shall conform to ACI 304 as modified by these specifications.
2. Placement Sequence: The sequence of concrete placement shall be coordinated in advance of actual placement to assure that construction joints will occur only as designed. Alternate sections of concrete walls and slabs shall be placed monolithically. Concrete for walls and slabs shall not be placed until seven days after placement of concrete for adjacent walls and slabs.
3. Notification: The District Representative shall be notified of readiness, not just intention, to place concrete in any portion of the work. This notification shall be such time in advance of the operation as the District Representative deems necessary for him to observe the preparations at the location of the proposed concrete placing. All forms, steel, screeds, anchors, ties, inserts and other items to be embedded shall be in place before notification of readiness is given to the District Representative.
4. Equipment Readiness: Sufficient primary and backup equipment shall be scheduled for continuous concrete placement, and anticipate what actions will be taken during interruption. Extra concrete vibrators shall be provided. Concrete vibrators shall be tested the day before placing concrete.
5. Removal of Water from Areas to Receive Concrete: Concrete shall not be placed until all water entering the space to be filled with concrete has been properly cut off or has been diverted by pipes or other means and carried out of the forms, clear of the work. Concrete shall not be placed underwater, nor shall still water be allowed to rise on any concrete until the concrete has attained its initial set. Water shall not be permitted to flow over the newly deposited concrete in such manner and of such velocity that will damage the surface finish.
6. Moisture Barriers: Where a moisture barrier is installed, the moisture barrier shall not be punctured by stakes or any other concrete accessories.
7. Concrete Pours and Freefall: Concrete shall be deposited at or near its final position to avoid segregation caused by rehandling or flowing. Concrete shall not be deposited in large quantities in one place to be worked along the forms with a vibrator. Concrete shall not be dropped freely into place from a height greater than 4 feet. Tremies shall be used where the drop could exceed these limits.
8. Consolidation of Concrete: Mechanical vibrators shall be used while placing concrete to eliminate rock pockets and voids, to consolidate each layer with that previously placed, to completely embed reinforcing bars and fixtures, and to bring just enough fine material to exposed surfaces to produce a smooth, dense, and even texture. Vibrators shall be of the high-frequency internal type, and the

number in use shall be able to consolidate the incoming concrete to a proper degree within 15 minutes after it is deposited in the forms. In all cases, at least two vibrators shall be available at the site. External vibrators shall be used for consolidating concrete only when the concrete is otherwise inaccessible for adequate internal consolidating.

9. Protection of Concrete: Concrete shall not be placed during rainstorms. Concrete placed immediately before rain shall be protected to prevent rainwater from coming in contact with it. Sufficient protective covering shall be kept on hand at all times for this purpose.

D. Concrete Tests

1. General: Strength tests shall be performed on the concrete by the District Representative as follows:
 - a. Mold and cure five concrete test cylinders from each 50 cubic yards, or fraction thereof, of each class of concrete placed in any one day. Mold and cure the cylinders in accordance with ASTM C31.
 - b. Test cylinders in accordance with ASTM C39. Test one cylinder at 7 days for information. Test one cylinder at 14 days for information. Test two cylinders at 28 days for acceptance. Hold one cylinder for verification. The test results shall be the average of the strengths of the two cylinders tested at 28 days. If one cylinder in a test manifests evidence of improper sampling, molding, or testing, other than low strength, discard it and use the fifth cylinder for the test result.
 - c. Determine slump of the concrete using ASTM C143 for each strength test sample and as required to establish consistency.
 - d. Determine air content of the concrete using ASTM C231 for each strength test sample and as required to establish consistency.
2. Notification and Handling of Samples: To facilitate testing and inspection:
 - a. The District shall be advised in advance of concrete placing operations to allow for completion of quality tests.
 - b. Labor necessary to assist the District Representative in obtaining and handling samples at the project shall be furnished by the Contractor.
 - c. Facilities for safe storage and proper curing of concrete test specimens on the project site, as required by ASTM C31 shall be provided and maintained by the Contractor for the sole use of the District.
3. Requirements for Attainment of Compressive Strength: Concrete shall attain the 28-day strength specified. The average value of concrete strength tests shall be equal to or greater than the specified 28-day strength. Not more than 10% of the tests shall be less than the specified 28-day strength. No test shall be less than 90% of the specified 28-day strength.
4. Failure to Attain Specified Strength: If the 28-day tests fail to meet the specified minimum compressive strength, the concrete will be assumed to be defective and

one set of three cores from each area may be taken as selected by the District Representative and in accordance with ASTM C42. If the average compressive strength, of the set of three concrete cores fails to equal 90% of the specified minimum compressive strength or if any single core is less than 75% of the minimum compressive strength, the concrete will be considered defective and shall be removed and replaced, all at no cost to the District. Costs of coring, testing of cores, and all required repairing pertaining thereto shall be the responsibility of the Contractor.

E. Pumping Concrete

1. Equipment Capacity Requirements: Pump size shall be determined by the rate of concrete placement, length of delivery pipe or hose, aggregate size, mix proportions, vertical lift, and slump of concrete.

Minimum inside diameter of pipe or hose shall be based on the maximum aggregate size as follows:

1-inch-max aggregate:	2 inches min ID
1 1/2-inch-max aggregate:	4 inches min ID

2. Disallowance of Aluminum Pipe: Aluminum pipes shall not be used for delivery of concrete to the forms.
3. Priming: Before pumping is started, the delivery pipe or hose shall be primed by pumping mortar through the line using 5 gallons of mortar for each 50 feet of delivery line. Mortar shall be pumped to waste and not deposited in the forms.

F. Hot Weather Requirements

1. General: During hot weather, proper attention shall be given to ingredients, production methods, handling, placing, protection, and curing to prevent excessive concrete temperatures or water evaporation in accordance with ACI 305 and the following. There shall be no additional reimbursement for costs incurred for placing concrete in hot weather.
2. Cooling Methods: When the weather is such that the temperature of the concrete as placed would exceed 90°F, ice or other effective means of cooling the concrete during mixing and transportation shall be used so that the temperature of the concrete as placed will not exceed 90°F.
3. Prevention Against Early Setting of Concrete: Precautions shall be taken when placing concrete during hot, dry weather to eliminate early setting of concrete. This includes protection of reinforcing from direct sunlight to prevent heating of reinforcing, placing concrete during cooler hours of the day, and the proper and timely application of specified curing methods.

G. Cold Weather Requirements

1. General: Adequate equipment shall be provided for heating concrete materials and protecting concrete during freezing or near-freezing weather in accordance with ACI 306 and the following. There shall be no additional reimbursement for costs incurred for placing concrete during cold weather.

2. Heated Mixing Water: When the temperature of the surrounding atmosphere is 40°F or is likely to fall below this temperature, the mixing water shall be heated to, but not exceed, 140°F. The heated water shall not be allowed to come in contact with the cement before the cement is added to the batch.
3. Temperature Requirements: When placed in the forms during cold weather, the concrete temperature shall be maintained at not less than 55°F. All materials shall be free from ice, snow, and frozen lumps before entering the mixer.
4. Curing Requirements: The air and the forms in contact with the concrete shall be maintained at temperatures above 40°F for the first five days after placing, and above 35°F for the remainder of the curing period. Thermometers shall be provided by the Contractor to indicate the ambient temperature and the temperature 2 inches inside the concrete surface.

H. Bonding to Existing Concrete

Existing concrete to which new concrete is to be bonded shall have the contact surfaces coated with epoxy bonding compound. The method of preparation and application of the bonding compound shall conform to the manufacturer's printed instructions and recommendations for specific application for this project.

I. Grouting Machinery Foundations

During placement of machinery, concrete shall be blocked out or finished off a sufficient distance below the bottom of the machinery base to provide for the thickness of grout shown on the drawings. After the machinery has been set in position and wedged to the proper elevation by steel wedges, the space between the bottom of the machinery base and the original pour of concrete shall be filled with a pourable nonshrink grout.

END OF SECTION

SECTION 03345: CONCRETE FINISHING, CURING, AND WATERPROOFING

PART 1 - GENERAL

A. Description

This section describes materials and methods of concrete finishes, curing, repair of defects, surface protection, and waterproofing.

B. Related Work Specified Elsewhere:

1. Concrete Formwork: 03100
2. Concrete Reinforcement: 03201
3. Concrete Joints and Waterstops: 03260
4. Concrete: 03300

C. Submittals

1. Shop drawings shall be submitted in accordance with the General Provisions and as specified herein.
2. Curing Compound: Submit manufacturer's statement of compliance with these specifications and recommended coverage to meet or exceed the specified tests. Submit manufacturer's application instructions.

PART 2 - MATERIALS

A. Curing Compound

1. General: Curing compound shall conform to ASTM C309, Type 1, Class B, and shall be compatible with required finishes and coatings.
2. Manufacturers: Curing compound shall be Kure-N-Seal manufactured by BASF or Super Diamond Clear 350 manufactured by Euclid Chemical Co.

B. Mortar for Repair of Concrete

Mortar used for repair of concrete shall be made of the same materials as used for concrete, except that the coarse aggregate shall be omitted and the mortar shall consist of not more than one part cement to two and one-half parts sand by damp loose volume. The quantity of mixing water shall be no more than necessary for handling and placing.

C. Roof Membrane for Underground Reservoirs

1. General Requirements: The reinforced membrane shall be a compounded Hypalon rubber elastomer-coated fabric conforming to the following requirements:

<u>Property</u>	<u>Std/Test Method</u>	<u>Minimum Specification</u>
Thickness:		
Total, overall	ASTM D751	41 mils
Minimum over scrim	Optical Method	11 mils
Tensile Properties each direction):	ASTM D751	
Breaking strength	Grab Method	
Fabric		90 lbs.
Membrane rupture		120 lbs.
Elongation at break		
Fabric		15 %
Membrane rupture		150 %
Tear Propagation	ASTM D751 Tongue Tear (8" X 8" sample)	16 lbs.
Hydrostatic Resistance	ASTM D751 Method A Procedure 1	140 psi
Puncture Resistance	FTMS D101B Method 2031	180 lbs.
Bonded Seam Strength	ASTM D751 Modified (12 in./min)	96 lbs.
Ply Adhesion	ASTM D413 Machine Method Type A (12 in./min)	10 lbs./in- width (or film tearing bond)
Ozone Resistance	ASTM D1149 1/8" bent loop, 100 pphm, 104°F, seven days	No cracks at 7X magnification
Low Temperature	ASTM D2136 1/8" mandrel, four hours at -40°F	Pass

2. Cover Material and Supporting Fabric: The thermoplastic elastomer cover material shall be manufactured totally by calendering, with each ply of rubber laminated to the next ply through the openings in the scrim weave to produce a pinhole-free construction. The open-weave polyester supporting fabric (scrim) shall have a 16 X 8, 2:1 leno weave 140 warp/250 fill denier with an 8 X 8-250d apparent construction. The two plies of supporting fabric shall be totally encapsulated within three plies of rubber, giving a five-ply construction of nominal 45-mil thickness. Exposed fabric or indication of delamination will not be permitted.
3. Cover Material Elastomer: The thermoplastic elastomer cover material shall be manufactured from a synthetic rubber compound designed to contain Hypalon Type 45 synthetic rubber as the sole elastomer and formulated in accordance with the recommendations of E. I. DuPont Company of Wilmington, Delaware.
4. Sheet Size: Basic calendered sheet size shall be 54-inch minimum width and fabricated at the membrane manufacturer's plant into one sheet to fit membrane size identified on the drawings.
5. Color: The material shall be furnished with the exposed side black. The color shall be "built in" to the material.

D. Protective Cover For Roof Membranes

Protective cover shall be 1/2-inch thick fiberboard treated to resist decay from earth materials and groundwater. Provide largest size sections that are available.

E. Crystalline Waterproofing

Waterproofing shall be "XYPEX" crystalline waterproofing.

PART 3 - EXECUTION

A. Concrete Finishes

Concrete surfaces shall be completed in accordance with the following schedule:

Concrete Finishes		
Finish Designation	Applicable Surfaces	Requirements
E-1	Exposed edges of slabs, floors, footings, and tops of walls.	Shall be finished with a 3/4-inch-radius edger, where chamfer is not indicated.
F-1	Exterior walls exposed to water or groundwater, and interior of tank walls.	Concrete surface defects shall be repaired, fins exceeding 1/4-inch in height shall be chipped or rubbed off, depressions 1/4-inch or deeper shall be filled, and form-tie holes shall be filled.
F-2	Walls, structures, or building walls exposed to view. Underside of formed floors or slabs.	In addition to repairs of Finish F-1, depressions and air holes 1/4-inch or deeper shall be opened by whip-blasting and filled with mortar. Surfaces shall be dampened and a slurry consisting of one part cement and one and one-half part sand by damp loose volume shall be spread over the surface with clean burlap pads or sponge rubber floats. Any surplus shall be removed by scraping and then rubbing with clean burlap.
S-1	Non-water bearing slabs and floors	Non-water bearing slabs and floors shall receive a light broom finish.

B. Finishing of Formed Surfaces

1. Curing Requirement: Surfaces shall be water cured until finishing and repairing are completed.
2. Repair of Surface Defects: Immediately after forms are removed, fins and irregularities shall be removed by grinding or rubbing. Depressions deeper than specified shall be filled with mortar, and form-tie holes filled.
3. Form-tie Holes: Form-tie holes shall be reamed with toothed reamers until surface of hole is rough and clean. Surface shall be coated with epoxy bonding compound and filled with mortar. Tapered form-tie holes shall be finished as follows:
 - a. Form-tie holes shall be sandblasted and blown clean prior to filling.
 - b. A rubber plug, with one end open, shall be driven to the center of the hole. Plug size shall be larger in diameter than the diameter of the hole at the center of the wall.
 - c. The entire annular surface of the hole shall be coated with epoxy prior to filling with mortar. Epoxy shall be applied in accordance with manufacturer's instructions.
 - d. Each side of hole shall be filled with mortar. Mortar shall be applied to the "wet" side of the wall first. Mortar shall be solidly consolidated into the hole.
 - e. The District Representative shall be notified in advance of the form-tie hole filling schedule.

C. Repair of Surface Defects

1. Repair Limits: Honeycombed and other defective concrete shall be removed down to sound concrete. Edges shall be perpendicular to surface. Surfaces to receive repair shall be sandblasted.
2. Bonding Compound: Sandblasted surface shall be coated with epoxy bonding compound.
3. Mortar Placement: Mortar shall be placed in layers having a compacted thickness of 3/8-inch. The surface of each layer shall be scratched to promote bonding with next layer. Finish repair shall match adjacent concrete and cure as specified.
4. Repair of Large Defective Areas: Defective areas of more than 1 foot square and deeper than the reinforcing steel shall be repaired as above, with the exception that the area shall be filled with pneumatically applied concrete.

D. Curing

1. Allowable Curing Methods: Concrete surfaces shall be cured by water curing or by use of sprayed curing compound at the Contractor's option. Where wooden forms are used, the forms shall be wet immediately before concreting and keep moist by sprinkling until removed. All exposed surfaces of formed concrete shall be kept moist until curing compound is applied.
2. Curing Compound Method
 - a. Curing compound shall be applied immediately after completion of the finish on unformed surfaces, and within two hours after removal of forms on formed surfaces. Formed surfaces shall be repaired within the said two-hour period; provided, however, that any such repairs which cannot be made within the said two-hour period shall be delayed until after the curing compound has been applied. When repairs are to be made to an area on which curing compound has been applied, the area shall first be sandblasted to remove the curing compound, then repaired.
 - b. The surface shall be sprayed with two coats of liquid curing compound. Curing compound shall be applied in accordance with the manufacturer's instructions to cover the surface with a uniform film which will seal thoroughly. A second coat shall be applied at 90 degrees to the direction of spray for the first coat.
 - c. Form, shoring, or wall bracing removal time shall be in accordance with Section 03100, Concrete Formwork.
 - d. Wherever curing compound may have been applied to surfaces against which concrete subsequently is to be placed and to which it is to adhere, the curing compound shall be removed entirely by sandblasting prior to the placing of new concrete.
 - e. Care shall be taken to avoid damaging the seal during the curing period. Damaged or broken seals shall be repaired immediately by the application of additional curing compound.

E. Roof Membrane

1. Factory Seams: All factory seams for either fabrication or repairs shall provide a minimum overlap of the reinforcing fabric of 1 inch and shall extend to the edge of the sheet so that no loose edge is present on the top side of the sheet. A loose edge on the underside of the sheet is permissible as long as the 1-inch minimum overlap of the reinforcing fabric is maintained and a minimum of 1-inch bonded seam is maintained within the overlap.
2. Field Seams: Field seam, if required, shall provide a minimum overlap of the reinforcing fabric of 2 inches and shall extend to the edge of the sheet so that no loose edge is present on the top side of the sheet. A loose edge on the underside of the sheet is permissible as long as the 2-inch minimum bonded overlap of the reinforcing fabric is maintained. A nominal 6-inch overlap of liner panels shall be allowed to keep dirt out of the field seams.
3. Surface Preparation: Concrete surfaces that are to receive Hypalon adhesive shall be thoroughly cleaned. Adhesive shall be applied in accordance with manufacturer's recommendations.

F. Protective Cover for Roof Membranes

Boards shall be butted tightly and shall cover the entire membrane surface, and overlap beyond the end of the membrane as indicated. Suitable adhesive shall be applied to the prepared concrete surface at the ends of the boards.

G. Crystalline Waterproofing

1. General: Preparation of and application to concrete surface shall be in accordance with manufacturer's recommendations.
2. Application Rate: Waterproofing shall consist of one coat of XYPEX "Concentrate" applied at the rate of 1-1/2 pounds per square yard of concrete surface, followed by one coat of XYPEX "Modified" applied at the rate of 1-1/2 pounds per square yard of concrete surface.
3. Areas to be Waterproofed: Waterproofing shall be applied to all walls from the top of the footing to top of walls (except wall areas receiving membrane and protective cover).

END OF SECTION

SECTION 03461: PRECAST CONCRETE MANHOLES & BASES

PART 1 - GENERAL

A. Description

This section includes materials, testing, and installation of precast concrete manholes, manhole bases, manhole frames and covers.

B. Related Work Specified Elsewhere

1. Structure Earthwork: 02200
2. Trenching, Backfilling, and Compacting: 02223
3. Pavement Removal and Replacement: 02578
4. Concrete: 03300
5. Painting and Coating: 09900
6. Leakage & Infiltration Testing: 15043

C. Submittals

1. Shop drawings shall be submitted in accordance with the General Provisions and as specified herein.
2. Submit manufacturer's catalog and test data on precast concrete manholes, frames, and covers along with installation recommendations for inlet and outlet seals and watertight caulking. Show dimensions and materials of construction by ASTM reference and grade. Show manhole cover lettering and pattern.

PART 2 - MATERIALS

A. Precast Concrete Manholes

1. General: Precast reinforced concrete manholes shall comply with ASTM C478, with a minimum wall thickness of 6-inches. The ASTM standard and manufacturer shall be stamped on the interior and exterior of all manhole shafting and cone.
2. Design Load: Manhole components shall be designed for H-20 highway loads and site soil conditions.
3. Concrete: Precast reinforced concrete manhole risers and tops shall be constructed of Class A concrete with Type II or Type V cement in accordance with Section 03300, Concrete.
4. Manhole Section Configuration: Manholes shall be fabricated only from eccentric taper sections and standard cylinder units of the proper internal diameter.

5. Manhole Section Dimensions: Unless noted otherwise, minimum diameter and wall thickness of manholes and manhole sections shall be as follows:

Depth of Cover (feet)	Manhole Diameter (inches)	Manhole Section Wall Thickness (inches)
0-15	48	6
15 1/2 -22	60	6
Greater than 22 1/2	72	7

Depth of cover shall be measured from proposed finish surface elevation to the elevation of the top of the manhole base.

6. Steps: Manhole sections shall be cast without steps.
7. Manufacturers: Precast reinforced concrete manholes shall be manufactured by Inland Concrete Products (Oldcastle Precast), Manhole Builders, Manhole Construction Specialist, Olson Precast Company, Precon Products, or Southwest Concrete Products (CalPortland).
8. Warning Signs: Warning signs shall be stenciled onto the vertical wall of the uppermost cone section of every manhole, as shown on IRWD Standard Drawing S-1.

B. Manhole Frames and Covers

1. General Requirements: Manhole frames and covers shall be made of ductile iron conforming to ASTM A536, Class 400, or cast iron conforming to ASTM A48, Class 30 minimum. Casting shall be smooth, clean, and free from blisters, blowholes, and shrinkage. Frames and covers shall be of the traffic type, designed for H-20 loading.
2. Fit and Matchmarking: Each manhole cover shall be ground or otherwise finished so that it will fit in its frame without rocking. Frames and covers shall be matchmarked in sets before shipping to the site.
3. Cover Inscription: Covers shall have the words "IRWD", "SEWER", and the country of origin cast thereon as shown in IRWD Standard Drawing S-1 or on the plans. No other lettering on the top side shall be permitted.
4. Cast letters shall be 3-inches and the relief depth shall be at least 3/16-inch. Top surface of the letters and diamond tread pattern shall be flush with the outer ring edge and the frame top surfaces.
5. Inspection and Coating: Before leaving the foundry, castings shall be cleaned and subjected to a hammer inspection. Castings shall then be dipped twice in a preparation of asphalt and oil applied at a temperature of not less than 290°F, not more than 310°F, and in such a manner as to form a firm and tenacious coating.
6. Manufacturers: Manhole frames and covers shall be manufactured by Alhambra Foundry, National Casting, Neenah Foundry, or South Bay Foundry.

C. Imported Sand

Imported sand shall comply with Section 02223, Trenching, Backfilling, and Compacting.

D. Crushed Rock

Crushed rock shall comply with Section 02223, Trenching, Backfilling, and Compacting. Crushed rock shall be the same material as the pipe bedding. If rock is not used for the pipe bedding, 3/4-inch crushed rock shall be used for the manhole. Crushed rock base material shall extend 1 foot beyond the outside edge of the concrete manhole base.

E. Manhole Bases

Concrete used in pouring the manhole base shall be Class A concrete, Type II or Type V cement in accordance with Section 03300, Concrete.

F. Cement-Mortar Grout

Grout for grade-ring joints between precast sections shall be composed of one part portland cement to two parts of clean well-graded sand of such size that all pass a No. 8 sieve. Cement, aggregate, and water for mortar shall conform to the applicable provisions of Section 03300, Concrete.

G. Epoxy Grout

Epoxy grout shall be used in repairing manhole and manhole base surfaces. Epoxy grout shall be made with epoxy and sand. The sand shall be clean, bagged, graded, and kiln dried silica sand. The prepared grout shall wet the contact surface and provide proper adhesion, or a coat of epoxy shall be applied prior to placing the epoxy grout. The epoxy bonding compound shall be in accordance with Section 03300, Concrete.

H. Plastic Joint Sealing Compound

Preformed, cold-applied, ready-to-use, plastic joint sealing compound for water-tight joints shall be Ram-Nek Joint Seal and shall be used on all manhole joints unless otherwise directed by the District Representative.

PART 3 - EXECUTION

A. Work Within Existing Manholes

Any proposed work inside an existing manhole that is part of a sewage system in service, shall not be undertaken until all the tests and safety provisions of Article 4, Section 1532 "Confined Spaces" State of California Construction Safety Orders have been made.

B. Excavation

Excavation for the precast concrete manhole shall be in accordance with Section 02223, Trenching, Backfilling, and Compacting.

C. Manhole Base

1. General: Manhole bases shall be poured in place against undisturbed soil with Class A concrete having 1-inch maximum size aggregate and a slump of not greater than 4-inches. The manhole base shall be poured as one monolithic pour. Specifications for ready-mixed concrete are set forth in Section 03300. If soil conditions are not adequate as determined by the District Representative, a specified depth of over-excavation shall be required and the re-fill material shall be placed in accordance with Section 02223 prior to the placement of concrete.
2. Manhole Stub Placement: The manhole stubs and sewer main shall be set before the concrete is placed and shall be rechecked for alignment and grade before the concrete has set. The various sized inlets and outlets to the manhole shall be constructed as shown in IRWD Standard Drawing S-1.
3. Matching Pipe Crown Elevations: Invert elevations of connecting sewers may vary depending upon sizes. The crown elevation of all pipes shall be the same as the crown elevation of the largest pipe unless otherwise indicated on the plans.
4. Channel Configuration: The invert of the manhole base shall be formed so as to provide smooth channels conforming in size and shape to the lower portions of the inlet and outlet pipes. The channel shall vary uniformly in size and shape from inlet to outlet, and a shelf shall be constructed higher than the pipe as indicated on the drawings. The manhole base shall extend 12-inches below the bottom of the lowest pipe.
5. Transitions: All transitions shall be smooth and of the proper radius to give an uninterrupted transition of flow.
6. Finishing: The concrete base shall be shaped with a wood float and shall receive a hard steel trowel finish before the concrete sets.
7. Curing Time Before Further Construction: Unless approved otherwise by the District, in advance, the bases shall set a minimum of 24 hours before the manhole construction is continued.

D. Installing Manholes

1. General: Manholes shall be constructed as shown on IRWD Standard Drawing S-1. Manholes for larger diameter sewers shall be constructed as shown on the plans.
2. Joints for Grade-Rings: Precast concrete manhole units shall be set in a bed of grout to make a watertight joint at least 1/2-inch thick with the concrete base or with the preceding unit. Manhole sections shall be set perfectly plumb. Joints shall be pointed and troweled and smoothed inside and outside of the manhole shaft joint. The excess grout shall be wiped off and removed.
3. Finish Elevation of Manhole Covers: Precast sections shall be assembled so that the cover conforms to the elevation determined by the manhole location as follows, but limited to a maximum of 18 inches of grade ring unless otherwise instructed by the District Representative.
 - a. Paved Area: Top of cover shall be flush with the paving surface.

- b. **Un-paved Areas:** Top of cover shall be flush with the existing surface where it is in the "traveled way" or shoulder and the concrete pad shall be 2 inches above the adjacent unpaved surface.
4. **Manhole Frame and Cover:** The manhole frame shall be secured to the grade ring with grout and cement mortar. After the frames are securely set, the frames and the covers shall be cleaned and scraped free of foreign materials, and shall be ground or otherwise finished as needed so the cover fits in its frame without rocking. The top surface of manhole covers and frames shall be coated in accordance with Section 09900, Painting and Coating. The manhole frame and cover shall be constructed per IRWD Standard Drawing S-1 at interim and final condition.
5. **Watertightness:** Manholes and appurtenances shall be watertight and free from infiltration. Enough cold-applied, preformed, bitumen based joint sealing compound shall be applied such that the compressed material protrudes from the interior and exterior of each manhole joint. The excess material on the interior shall be trimmed flush.
6. Where called for on the plans or supplemental or project technical specifications, manholes that are to be given a protective lining or coating shall be free of any seeping or surface moisture. The adequacy of manholes and appurtenances as to watertightness shall be determined by the District Representative and shall be tested in accordance with Section 15043, Leakage and Infiltration Testing.
7. **Stubs:** Sewer pipe shall be furnished and installed in manholes at the locations shown and in conformance with the detail drawings and plans. All stubs shall be plugged with stoppers as shown on the plans for various sizes of pipe.
8. **Sealing Before Completion:** In order to prevent accidental use of the new sewer before completion and acceptance, the inlet to existing tie-in manholes shall be sealed with broken brick and mortar. Installation of these plugs shall be approved by the District Representative. Plugs shall be removed at the time of final inspection or as directed by the District Representative.
9. **Bulkheads:** Brick and mortar bulkheads shall be installed at the downstream end of all unused stub channels to prevent the creation of a septic condition resulting from ponding of sewage and debris in the unused channels, and until such time as the manhole stub is connected and normal sewage flow can occur.
10. **New Connections to Existing Manholes:** New connections to existing manholes wherein stubs have not been provided shall be made by core drilling through the base, as directed by the District Representative.
11. **Backfill:** Backfill around the precast concrete manhole shall be approved native or imported material, and shall be placed and compacted in accordance with Section 02223, Trenching, Backfilling, and Compacting.
12. **Concrete Collar:** Class B concrete collar shall be cast around manhole frames that are flush with the surface. The collar shall be placed with each lift.
13. **Pavement Replacement:** Replacement of bituminous or concrete pavement shall be in accordance with Section 02578, Pavement Removal and Replacement.

E. Manhole and Manhole Base Repairs

Manhole sections and bases that exhibit defects in the concrete surface may be rejected for the reasons such as exposure of reinforcement, shattered concrete or cracks having a width of 0.01 inch or more throughout a continuous length of 1 foot or more. Defective concrete surfaces of manhole sections and bases not rejected shall be repaired by chipping away unsound or imperfect concrete. Edges shall be left sharp and square with the surface. Loose material and dust remaining after chipping shall be removed by means of an air jet. Epoxy grout shall be applied to the surface to be repaired in accordance with the manufacturer's instructions. The grout shall wet the contact surface and provide proper adhesion, or a coat of epoxy shall be applied prior to placing the epoxy grout.

F. Manhole Coatings

Where called for in the plans or supplemental specifications, manhole coatings shall be provided. The requirement for manhole coatings shall be in accordance with Section 09900, Painting and Coating.

END OF SECTION

SECTION 03462: PRECAST CONCRETE VAULTS AND METER BOXES

PART 1 - GENERAL

A. Description

This section describes the materials, manufacture, and installation of precast concrete vaults and meter boxes.

B. Related Work Specified Elsewhere

1. Structure Earthwork: 02220
2. Trenching, Backfilling and Compacting: 02223
3. Concrete Joints and Waterstops: 03260
4. Concrete: 03300
5. Structural Steel and Miscellaneous Metalwork: 05120

C. Submittals

1. Shop drawings shall be submitted in accordance with the General Provisions and as specified herein.
2. Submit manufacturer's catalog data on precast concrete vaults and meter boxes. Show dimensions and materials of construction by ASTM reference and grade.

PART 2 - MATERIALS

A. Precast Concrete Vault

1. Manufacturers: Precast concrete vaults and covers shall be manufactured in a plant specifically designed for that purpose and shall conform to the size, shape and dimensions indicated on the detailed plans. The ASTM standard and manufacturer shall be stamped on the interior and exterior of vault. Vaults and covers shall be Christy Concrete, Eisel Enterprises, Inc., J & R Concrete Products, Inc., Jensen Precast, or Olson Precast.
2. Design Loads: Design loads shall consist of dead load, live load, impact, and in addition, loads due to water table and any other loads which may be imposed upon the structure. Live loads shall be based on H-20 continuous loading per AASHTO standard specifications for highway bridges. Design wheel load shall be 16 kips. The live load shall be that which produces the maximum shear and bending moments in the structure.
3. Concrete: Concrete for vaults and meter boxes units shall be Class A in accordance with Section 03300, Concrete.
4. Sectional Vaults: Sectional precast concrete vaults may be used only where specified on the drawings or approved by the District Representative.

B. Precast Meter Boxes and Covers

1. Materials: These boxes and covers shall be reinforced polymer/plastic mortar.
2. Meter Box Covers: Meter box covers with reading lid shall be manufactured of reinforced polymer/plastic mortar in two separate rectangular pieces.
3. Traffic Covers: Meter box covers within roadways or driveways shall be cast-iron or steel designed to withstand continuous H-20 highway loading. "IRWD" shall be welded on the inner lid. The covers shall have a hinged metal reading lid only where specified on the plan or approved by the District Representative.
4. Manufacturers: Meter boxes shall be manufactured of reinforced polymer/plastic mortar by Armorcast Products Company, J&R, Inc., or New Basis.

Item	Meter Size 5/8-inch to 1-inch (inches)	Meter Size 1 1/2-inch & 2-inch (inches)
Meter Box Size Nominal inside dimensions	13 wide x 24 long x 12 deep	17 wide x 30 long x 12 deep

C. Vault Frames and Covers

Unless noted otherwise, vault access hatches and frames shall be fabricated in accordance with the requirements of Section 05120, Structural Steel and Miscellaneous Metalwork.

D. Joint Sealing Compound

The joint sealing compound shall be permanently adhesive flexible plastic material complying with Federal Specification SS-S-00210 (GSA-FSS). Joint sealing compound shall be Quickseal by Associated Concrete Products.

PART 3 - EXECUTION

A. Earthwork

1. General: Excavation and backfill for precast concrete vaults and meter boxes shall be in accordance with Section 02220, Structure Earthwork, and the requirements herein. Excavation limits shall be large enough to accommodate the structure and permit grouting of openings and backfilling operations.
2. Sub-base: Unless otherwise shown on the plans, the bottom of the structure shall be placed on 12-inches of compacted, crushed rock sub-base, graded level and to the proper elevation as shown in the IRWD Standard Drawings or on the plans, and shall conform to Section 02220, Structure Earthwork.

B. Vault Installation

1. Vault Wall Openings: Openings or "knockouts" in precast concrete vaults shall be located as shown on the drawings and shall be sized sufficiently to permit passage of the largest dimension of pipe and/or coupling flange. Wall penetrations shall be as shown in the IRWD Standard Drawings. Upon completion of installation, all penetrations or openings in the vault walls that are

less than 2 1/2-inches in diameter shall be filled with non-shrink Class A concrete or mortar, using an epoxy for bonding concrete surfaces, as specified in Section 03300, Concrete. Pipe or conduits shall be wrapped in "swell-stop" prior to the placement of non-shrink grout.

2. Backfill: After the structure and all appurtenances are in place and approved, backfill shall be placed to the original groundline or to the limits designated on the plans.
3. Watertightness: All joints between precast concrete vault sections shall be made watertight. The sealing compound shall be installed according to the manufacturer's recommendations to provide a watertight joint. Pipe and conduit penetrations shall also be water-tight.
4. Installed Elevation: Vaults located within roadways shall be installed flush with the finished grade. All other vaults shall be built up so that the cover is 0.1 foot above the surrounding surface, unless otherwise specified on the drawings or directed by the District Representative in the field. The Contractor is responsible for placing the cover at the proper elevation and slope where paving is to be installed, and shall make all necessary adjustments so that the cover meets these requirements.

C. Meter Box Installation

1. Line and Grade: Meter boxes shall be set true to line and to the grade of the top of the curb, sidewalk. For landscaped, or other unpaved surfaces, the meter box shall be set with the top 0.1 foot above the adjacent surrounding area, or as directed by the District Representative in the field. The Contractor is responsible for placing the cover at the proper elevation and slope, and shall make all necessary adjustments so that the cover meets these requirements.
2. Sequence of Installation: Meter boxes shall not be set until fine grading or landscape grading in the vicinity has been completed.

D. Waterproof Coating

Where called for on the plan and at a minimum where ground water is encountered, the exterior of precast vault and meter boxes shall be coated in accordance with Section 03345, Concrete Finishing, Curing, and Waterproofing.

END OF SECTION

SECTION 05120: STRUCTURAL STEEL AND MISCELLANEOUS METALWORK

PART 1 - GENERAL

A. Description

This section describes materials and installation of structural steel, connecting bolts, stainless-steel fasteners, ladders, access hatches, and gratings.

B. Related Work Specified Elsewhere

1. Concrete: 03300
2. Painting and Coating: 09900
3. Standard Specifications for Public Works Construction

C. Submittals

1. Shop drawings shall be submitted in accordance with the General Provisions and as specified herein.
2. Submit drawings of fabricated items, such as pipe supports, bolts, ladders, concrete anchors, grating, and access hatches. Show dimensions and reference materials of construction by ASTM designation and grade.

PART 2 - MATERIALS

A. Structural Steel

Material for all-purpose bolted or welded construction shall conform to ASTM A36.

B. Aluminum

Structural shapes shall conform to ASTM B308, Alloy 6061-T6. Plates and sheets shall conform to ASTM B209. Tubing shall conform to ASTM B241.

C. Nuts, Bolts and Washers

Except where otherwise specified, washers shall be Type 316, ASTM A167. Bolts shall be ASTM A193, Grade B8M. Nuts shall be ASTM A194, Grade 8M.

D. Galvanizing

Zinc coating for all plates, bolts, anchor bolts, and threaded parts shall be hot-dipped coated in accordance with ASTM A153. Structural steel and pipe shall be zinc coated in accordance with ASTM A123.

E. Stainless Steel

Except where otherwise specified, stainless steel plate, members, and washers shall be Type 316, ASTM A167.

F. Welding Electrodes

Welding electrodes for structural steel shall conform to AWS A5.5. Use electrodes in the E-70 series. Welding electrode for aluminum shall be 4043 filler metal and Type 347 electrode for stainless steel.

G. Ladders

1. General: Ladders shall be fabricated as shown on the plans and shall comply with Cal OSHA Safety Standards Section §3277, Fixed Ladders. Ladders shall be of welded steel construction and hot-dip galvanized after fabrication or stainless steel where indicated on the drawings.
2. Ladder Safety Systems: Ladder Safety Systems shall be provided for all ladders over 20 feet, or where indicated on the plans. The device shall comply with Cal OSHA Section §3277, Fixed Ladders, requirements and shall have a 3M DBI-SALA Fixed Ladder Anchor For Self-Retracting Lifeline (Product Number 6100565, Stainless Steel, 6 feet) and a 3M DBI-SALA Sealed-Blok Self Retracting Lifeline (Product Number 3400135, Stainless Steel Cable, Swivel Snap Hook). Cable length shall be determined based on the design and needs of the facility.
3. Center Safety Post: All ladders 6-feet tall and greater and where a ladder safety system is not required, shall have a center post extension attached to the ladder in accordance with the IRWD Standard Drawing G-5. The center post shall be LadderUP Safety Post manufactured by Bilco.
4. Double Handrail Ladders: Where center safety posts (LadderUP Safety Post) cannot be installed, double handrail ladders as manufactured by Pipeline Products shall be provided.

H. Concrete Anchors

Drilled anchors shall be Type 316 stainless steel wedge anchors, unless otherwise indicated, as manufactured by Phillips Drill Company. Where steel anchors are indicated, they shall be one-piece design with expander ring consisting of steel zinc coated and chrome plated as manufactured by Kwik Bolt, McCullough Industries, Inc.

I. Access Hatches

Hatches may be of aluminum or stainless steel construction, as called for and specified on the project plans. In general, aluminum hatches maybe be used in applications of parkway loading (i.e., low-volume traffic with H-5 loading) where a severe corrosion environment is not present, (i.e., non-sewage applications).

Aluminum or stainless steel access hatches shall be of the size and type indicated on the drawings. Hardware shall be 316 stainless steel and shall include but not be limited to hinges, threaded pieces, connectors, hold-open arms, springs, and spring covers. Hatches shall be equipped with extruded aluminum channel trough frames with 1-1/2 inch drain

coupling, flush aluminum drop handles which do not protrude above the cover, a recessed padlock box and stainless steel staple sized for a No. 5 padlock, and shall be as manufactured by Bilco, or U. S. Foundry.

J. Metallic Grating

Unless noted otherwise, metallic grating shall be aluminum. Main bars shall be of the size and thickness indicated on the drawings.

PART 3 - EXECUTION

A. Fabrication and Erection

1. General: Miscellaneous metal items shall be fabricated to straight lines and true curves. Drilling and punching shall not leave burrs or deformations. Permanent connections shall be welded continuously along the entire area of contact. Exposed work shall have a smooth finish with welds ground smooth. Joints shall have a close fit with corner joints coped or mitered and shall be in true alignment. Unless specifically indicated, there shall be no bends, twists, or open joints in any finished member nor any projecting edges or corners at intersections. Fastenings shall be concealed wherever possible. Built-up parts shall be free of warp. Exposed ends and edges of metal shall be slightly rounded. All bolt holes shall be 1/16-inch in diameter larger than bolt size. Cast-in-place bolt locations shall be measured in the field before drilling companion holes in structural steel beam or assembly.
2. Surfaces in Contact with Concrete: Surfaces of metalwork to be in contact with concrete shall be cleaned of rust, dirt, grease, and other foreign substances before placing concrete.
3. Embedded Metalwork: Embedded metalwork shall be set accurately in position when concrete is placed and supported rigidly to prevent displacement or undue vibration during or after the placement of concrete. Unless otherwise specified, where metalwork is to be installed in recesses in formed concrete, said recesses shall be made, metalwork installed, and recesses filled with dry-pack mortar in conformance with Section 03300, Concrete.

B. Ladders

Ladder rungs shall be 3/4-inch round, unless otherwise noted. The distance between rungs, cleats, and steps shall be spaced 12-inches on center. Ladders shall be mounted to provide clearance in back of ladder so that the distance from the centerline of rungs, cleats, or steps to the nearest permanent object in back of the ladder shall be not less than 7-inches.

C. Common Machine Bolts and Nuts

1. General: Bolts shall be inserted accurately into the bolt holes without damaging the thread. Bolt heads shall be protected from damage during driving. Bolt heads and nuts shall rest squarely against the metal. Where bolts are to be used on beveled surfaces having slopes greater than 1 in 20 with a plane normal to the bolt axis, beveled washers shall be provided to give full bearing to the head or nut.

2. Bolt Insertion: Bolts shall be of the length that will extend entirely through but not more than 1/4-inch beyond the nuts. Bolt heads and nuts shall be drawn tight against the work.

D. Anchor Bolts and Anchors

1. General: Bolts and anchors shall be preset by the use of templates. Concrete anchors shall not be used where cast-in-place anchor bolts are called for.
2. Protection of Anchor Bolts: After anchor bolts have been embedded, bolt threads shall be protected by applying anti-seize compound and by placing the nuts on the treaded bolt end until the time of installation of the equipment or metalwork.

E. Control of Flame Cutting

The use of a gas-cutting torch in the field for correcting fabrication errors on any member in structural framing shall not be permitted. A flame-cutting torch shall be used only on minor members, when the member is not under stress.

F. Repair of Galvanized Surfaces

Damaged galvanized metal surfaces shall be repaired or replaced at no additional cost to the District. Repair of galvanized surfaces shall be accomplished by use of Cold Galvanizing Repair Compound as manufactured by Rust-Oleum, applied in accordance with the manufacturer's instructions.

G. Storage of Materials

All material, either plain or fabricated, shall be stored above ground on platforms, skids, or other supports. Material shall be kept free from dirt, grease, and other foreign matter and protected from corrosion.

H. Welding

1. Steel: Welding of steel shall be performed by the Shielded Metal Arc Welding (SMAW) process. Welding procedures shall comply with AWS D1.1.
2. Aluminum: Welding of aluminum shall be performed by the Gas Metal Arc (MIG) or Gas Tungsten Arc (TIG) process, per the AWS Welding Handbook.

I. Grating

1. Measurement: Grated areas shall be field measured for proper size.
2. Banding: Grating shall be completely banded.
3. Grating Angles: Seat angles for grating shall be set so that the top of the vertical leg is flush with the concrete floor. Seat angles and anchors shall be stainless steel.

J. Corrosion Protection

Aluminum surfaces that are in contact with concrete shall be coated in accordance with Section 09900, Painting and Coating. Coating shall be allowed to dry before placing in or against concrete.

END OF SECTION

SECTION 09900: PAINTING AND COATING

PART 1 - GENERAL

A. Description

This section describes materials and application of painting and coating systems for submerged metal surfaces, exposed metal surfaces, buried metal surfaces, metal surfaces in contact with concrete, submerged concrete, exposed PVC and FRP pipe, and valves.

Coating thicknesses specified herein are given as "dry-film thickness" in mils. Mil thicknesses specified are minimums.

B. Related Work Specified Elsewhere

1. Structural Steel and Miscellaneous Metalwork: 05120
2. Carbon Steel Pipe and Fittings: 15053
3. Ductile-Iron Pipe and Fittings: 15056
4. Combination Air Release and Vacuum Relief Valves: 15089
5. Manual Valves: 15100
6. Hydrants: 15139
7. Flexible Pipe Couplings and Expansion Joints: 15162
8. Cathodic Protection and Joint Bonding: 16640

C. Submittals

1. Shop drawings shall be submitted in accordance with the General Provisions and as specified herein.
2. Submit manufacturer's data sheets showing the following information:
 - a. Recommended surface preparation.
 - b. Minimum recommended dry-film thicknesses per coat for prime and finish coats.
 - c. Percent solids by volume.
 - d. Recommended thinners.
 - e. Statement that the selected prime coat is recommended by the manufacturer for use with the selected finish coats.
 - f. Application instructions including recommended application, equipment, humidity, and temperature limitations.

3. Submit certification that all coatings conform to South Coast Air Quality Management District Rules and Regulations for products and application.

D. Pre-Submittal Meeting

A pre-submittal meeting shall be conducted two weeks prior to the submittal of coating shop drawings, at the discretion of the District Representative. The meeting shall be attended by the painting and coating (sub) contractor.

E. Air Quality Requirements

Materials shall comply with South Coast Air Quality Management District's Rule 1107 for shop coating and Rule 1113 for field coating.

F. Painting Systems

All paints shall be delivered to the jobsite in the original, unopened containers. All materials of a specified painting system, including primer, and finish coats, shall be produced by the same manufacturer. Thinners, cleaners, driers, and other additives shall be as recommended by the paint manufacturer for the particular coating system.

PART 2 - MATERIALS

A. Color System for Coatings and Coating System Summary

Unless noted otherwise, colors for surfaces that are to be coated shall be defined as follows:

Color	Pantone ID Number (closest match in sunlight)	Amershield Designation
Brown	PMS 1405	PMS 1405
Dark Blue	2766 C	Newport Coast # 33
Factory Finish	N/A	No Color Coating
Light Blue	2925 C	1159 Light Blue
Medium Bronze	N/A	Medium Bronze
Olive Light	IRWD Olive Light ¹	IRWD Olive Light ¹
Purple	512 C	PMS 512 C
Safety Green	348 U	1135 Safety Green
Safety Orange	021 C	OR-2 Safety Orange
Safety Red	485 C 2X	RO-1 Bright Red
Safety Yellow	U2X	Safety Yellow

¹IRWD Olive Light is a custom color that can be ordered by name from each specified manufacturer.

The following table provides a summary of the coating systems and the various surfaces to be coated:

Application	Utility	System No.											
		A-1	B-1	B-2	B-3	B-4	C-1	C-2	D-1	E-1	F-1	G-1	G-2
Public Hydrants, Valve Can Lids, and Test Box Lids	Potable & Recycled	X											
Submerged Metal	Potable			X									
Submerged Metal	Recycled		X										
Submerged Metal	Raw Water		X										
Submerged Metal	Raw Sewage				X								
Concrete Sewer Manholes and Submerged Concrete	Raw Sewage					X							
Exposed Metal	All						X	X					
Buried Metal	All								X				
Metal in Contact with Concrete	All									X			
Exposed PVC/FRP	All										X		
Valves	All											X	X

B. Specialty Items

Surfaces shall be coated as described below:

1. Valve Can & Test Box Lids: Valve can and test box lids shall be coated per System No. A-1.
2. Buried Items: Buried flanges, nuts and bolts, flexible pipe couplings, exposed rebar from thrust blocks, and valve boxes shall be coated per System No. D-1 unless otherwise specified in the particular specifications for these items.
3. Above Ground Structural Steel and Structural Steel in Vaults: Above ground structural steel or structural steel located in vaults and steel structures shall be coated as described in the exposed metal coating system sections.

4. Pipe Supports: All non-galvanized and non-stainless steel pipe supports in vaults shall be coated the same as the adjacent piping. If pipe is PVC, pipe supports shall be coated per System No. C-1.
5. Exposed Indoor Galvanized Electrical Conduit: Exposed indoor galvanized electrical conduit shall only be coated when specified in the project technical specifications. When specified, coating System No. C-3 shall be used.
6. Mechanical Equipment: Mechanical equipment, such as motors, shall be coated as described in the exposed metal coating system sections.
7. Pumps: The interior and exterior of the pump discharge head, suction bell, or elbow and bowls, or volute shall be coated per System No. G-1 for pumps in wells, sewage lift stations, domestic water pump stations, and recycled water pump stations. Impellers for pumps at sewage lift stations shall be coated per System No. G-1.

The pump column shall be coated as follows:

- a. Flanged Column – System No. G-1, interior and exterior
 - b. Threaded Column – No coating is required
8. Concrete Sewer Manholes: Concrete sewer manholes shall be coated with System No. B-4 if any of the following conditions exist.
 - a. If any sewer line connecting to a manhole has a slope of 7 percent or greater.
 - b. Wherever there is a change in slope, from steep to flat, of 5 percent or greater, the manhole at the grade change and the next manhole upstream shall be coated.
 - c. All manholes at the terminus of sewer force mains.
 - d. As specified in the District’s Procedural Guidelines and General Design Requirements.
 9. Concrete Sewer Manhole Covers and Frames: Surface preparation for concrete sewer manhole covers and frames shall be in accordance with SSPC SP-3. The top surface of manhole covers and frames shall be coated black with System No. C-2 with a minimum total dry-film thickness of 8 mils.

C. Public Hydrant, Valve Can Lids, and Text Box Lids Coating System

1. System No. A-1 -- Public Hydrants, Valve Can Lids, and Test Box Lids
 - a. Type: Water-based low Volatile Organic Compound (VOC) acrylic coating. Thinners, cleaners, driers, and other additives shall be as recommended by the paint manufacturer. A total dry-film consisting of the combined thickness of both a prime coat and finish coat is described herein. The total dry-film thickness of this system shall be 5 mils.

- b. Surface preparation: Remove oil, grease and chalking. Abrade existing paint and visible rust areas. Do not sandblast or prepare more surface area than can be coated in one day. Surface preparation shall conform to the Society for Protective Coatings (SSPC) specifications as follows:

- SP-1 Solvent Tool Cleaning
- SP-2 Hand Tool Cleaning
- SP-3 Power Tool Cleaning

- c. Color: See color schedule herein.
- d. Prime Coat: Apply to a dry-film thickness of 2 to 3 mils. Primer shall be synthetic. Approved manufacturers for previously painted surfaces include:
 - i. Carboline Carbocrylic 120;
 - ii. International/Devoe Deycryl 1448;
 - iii. PPG Pitt-Tech Plus 4216;
 - iv. Sherwin Williams Pro Industrial Acrylic; or
 - v. Tnemec Series 1028 Enduratone.

Approved manufacturers for bare metal surfaces include:

- i. Carboline Carbocrylic 120;
- ii. International/Devoe Deycryl 1448;
- iii. PPG Pitt-Tech Plus 4216;
- iv. Sherwin Williams Pro Industrial Pro-Cryl Universal Primer; or
- v. Tnemec Series 94-H20 Hydro-zinc.

- e. Finish Coat: Apply to a dry-film thickness of 3 to 4 mils. The finish coat shall be applied in the field just prior to final inspection. Approved manufacturers for finish coats include:
 - i. Carboline Carbocrylic 3359 MC;
 - ii. International/Devoe Deycryl 1448;
 - iii. PPG Pitt-Tech Plus 4216;
 - iv. Sherwin Williams Pro Industrial Acrylic; or
 - v. Tnemec Series 1028 Enduratone.

D. Submerged Metal and Concrete Coating Systems

- 1. System No. B-1 -- Submerged Metal, Recycled, and Raw Water
 - a. Type: Two part low VOC epoxy-polyamide. A total dry-film consisting of the combined thickness of both a prime coat and finish coat is described herein. The total dry-film thickness of this system shall be 20 mils.
 - b. Service Conditions: Shall be used on metal structures, pipes, or equipment including, but not limited to tanks, clarifier mechanisms, scum troughs, slide gates and other miscellaneous metal exposed to recycled water or raw water.
 - c. Surface Preparation: SSPC SP-10

- d. Prime Coat: Apply to a dry-film thickness of 8 mils. Approved manufacturers for prime coat include:
 - i. Carboline Carboguard 890 VOC;
 - ii. International/Devoe Bar-Rust 233H LV (Low VOC);
 - iii. PPG Protective and Marine Coatings, Amerlock 2 VOC or 400 VOC; or
 - iv. Tnemec Series L69 Hi-Build Epoxoline II.
- e. Finish Coats: Apply two coats, each with a 6 mil dry-film thickness to achieve the total dry-film thickness. The coating material shall be the same material as the prime coat.

2. System No. B-2 -- Submerged Metal, Potable Water

- a. Type: Two part low VOC epoxy-polyamide, or two-part amido-amine epoxy. A total dry-film consisting of the combined thickness of both a prime coat and finish coat is described herein. The total dry-film thickness of this system shall be 15 mils. Coating shall be NSF 61 approved.
- b. Service Conditions: Shall be used on surfaces including, but not limited to, structural steel, tank interiors and piping exposed to potable water.
- c. Surface Preparation: SSPC SP-10
- d. Prime Coat: Apply to a dry-film thickness of 5 mils. Approved manufacturers for prime coats include:
 - i. International/Devoe Bar-Rust 233H LV (Low VOC);
 - ii. PPG Protective and Marine Coatings, Amerlock 2 VOC or 400 VOC;
 - iii. Sherwin Williams Macropoxy 5500 LT; or
 - iv. Tnemec Series L140F Pota Pox.
- e. Finish Coats: Apply two coats, each with a 5 mil dry-film thickness, to achieve the total dry-film thickness. The coating material shall be the same material as the prime coat.

3. System No. B-3 -- Submerged Metal, Raw Sewage

- a. Type: 100% solids epoxy for metal surfaces. A total dry-film consisting of the combined thickness of both a prime coat and finish coat is described herein. The total dry-film thickness of this system shall be 40 mils.
- b. Service Conditions: Shall be used on metal structures or pipes exposed to raw sewage.
- c. Surface Preparation: Surface preparation shall be SSPC SP-10 for steel surfaces. Surface preparation shall be NAPF 500-03-05 Clean No. 2 for ductile iron or cast iron surfaces.
- d. Prime Coat: Apply to a dry-film thickness of 5 mils. Approved manufacturers include:

- i. Carboline Plasite 4550;
 - ii. International Enviroline 222;
 - iii. PPG Novaguard 810;
 - iv. Sherwin Williams Dura-Plate UHS; or
 - v. Tnemec Series 435 Perma-Glaze.
 - e. Finish Coat: Apply one coat with a 35 mil dry-film thickness, to achieve the total dry-film thickness. The coating material shall be the same material as the prime coat.
4. System No. B-4 -- Manholes and Submerged Concrete, Raw Sewage
- a. Type: 100% solids polyurethane system for concrete surfaces. A total dry-film consisting of the combined thickness of both a prime coat and finish coat is described herein. The total dry-film thickness of this system shall be 125 mils.
 - b. Service Conditions: Shall be used on concrete structures or pipes exposed to raw sewage including, but not limited to, junction structures, wet wells, manholes, and sumps.
 - c. Surface Preparation: Surface preparation shall be SSPC SP-13 for concrete surfaces. If the coating terminates mid-wall, the Contractor shall sawcut a termination strip 1/4-inch deep and 1/4-inch wide. Newly placed concrete shall cure for a minimum of 28 days before preparing the surface for coating.
 - d. Prime Coat: Apply to a dry-film thickness of 2 mils. Approved manufacturers include:
 - i. Sancon 100 epoxy primer; or
 - ii. Zebron epoxy primer.
 - e. Finish Coat: Apply one coat to achieve the total dry-film thickness. Approved manufacturers include:
 - i. Sancon 100 polyurethane; or
 - ii. Zebron polyurethane system.

E. Exposed Metal Coating Systems

1. System No. C-1 -- Exposed Metal, Severely Corrosive Environment
- a. Type: Low VOC Inorganic zinc prime coat with low VOC epoxy-polyamide finish coat. A total dry-film consisting of the combined thickness of both a prime coat and finish coat is described herein. The total dry-film thickness of this system shall be 12 mils.
 - b. Service Conditions: Shall be used on metal surfaces including, but not limited to, structures, piping, fittings, pumps, and appurtenances subjected to continuous water condensation, occasional immersion, or splashing. Below grade vaults shall be considered as severely corrosive environments.

- c. Surface Preparation: Surface preparation shall be SSPC SP-10 for steel surfaces. Surface preparation shall be NAPF 500-03-05 Clean No. 2 for ductile iron or cast iron surfaces.
- d. Prime Coat: Apply to a dry-film thickness of 3 mils. For ductile iron surfaces, the ductile iron shall have an asphaltic free surface with a factory applied prime coat the same as the finish coat. For all other surfaces, a two-component inorganic zinc rich primer shall be used with a minimum zinc content of 14 pounds per gallon. Approved zinc primer manufacturers include:
 - i. Carboline Carbozinc 11;
 - ii. International/Devoe Cathacoat 302V;
 - iii. PPG Protective and Marine Coatings, Amercoat 68HS VOC;
 - iv. Sherwin Williams Zinc Clad XI; or
 - v. Tnemec Series 94-H20 Hydro-zinc.
- e. Finish Coats: Apply two coats, each with a 4 to 5 mil dry-film thickness, to achieve the total dry-film thickness. Approved manufacturers include:
 - i. Carboline Carboguard 890 VOC;
 - ii. International/Devoe Devran 224 V;
 - iii. PPG Protective and Marine Coatings, Amerlock 2 VOC or 400 VOC;
 - iv. Sherwin Williams Macropoxy 646-100; or
 - v. Tnemec Series L69 Hi-Build Epoxoline II.

2. System No. C-2 -- Exposed Metal, Atmospheric Weathering Environment

- a. Type: Low VOC Aliphatic Polyurethane with low VOC epoxy-polyamide or amido-amine epoxy primer. A total dry-film consisting of the combined thickness of both a prime coat and finish coat is described herein. The total dry-film thickness of this system shall be 8 mils.
- b. Service Conditions: Shall be used on metal surfaces including, but not limited to, structures, piping, fittings, pumps, and appurtenances subjected to atmospheric elements and weathering.
- c. Surface Preparation: Surface preparation shall be SSPC SP-6 for steel surfaces. Surface preparation shall be NAPF 500-03-05 Clean No. 2 for ductile iron or cast iron surfaces. Surface preparation shall be SSPC SP-1 for galvanized surfaces and shall be brush blasted or acid etched surface prior to application of prime coat.
- d. Prime Coat: Apply one or two coats to a dry-film thickness of 5 mils. For ductile iron surfaces, the ductile iron shall have an asphaltic free surface with a factory applied prime coat the same as the finish coat. Approved manufacturers include:
 - i. Carboline Carboguard 890 VOC;
 - ii. International/Devoe BarRust 231;
 - iii. PPG Protective and Marine Coatings, Amerlock 2 VOC or 400 VOC;

- iv. Sherwin Williams Macropoxy 646-100; or
 - v. Tnemec Series 135 Chembuild with low VOC thinner or L69 Epoxyline.
- e. Finish Coat: Apply one coat to a dry-film thickness of 3 mils to achieve the total dry-film thickness. Approved manufacturers include:
- i. Carboline Carboguard 134 MC;
 - ii. International/Devoe Devthane 379;
 - iii. PPG Protective and Marine Coatings, Amersfield VOC;
 - iv. Sherwin Williams Pro Industrial Acrolon 100; or
 - v. Tnemec Series 1095 Endura-shield.

F. Buried Metal Coating Systems

1. System No. D-1 -- Buried Metal
- a. Type: Low VOC epoxy coating. A total dry-film consisting of the combined thickness of both a prime coat and finish coat is described herein. The total dry-film thickness of this system shall be 24 mils.
 - b. Service Conditions: Shall be used to coat buried metal including, but not limited to, valves, flanges, bolts and nuts, fittings, flexible pipe couplings, and structural steel.
 - c. Surface Preparation: SSPC SP-10
 - d. Prime Coat: Apply to a dry-film thickness of 8 mils. Approved manufacturers include:
 - i. Carboline Carboguard 890 VOC;
 - ii. International/Devoe Bar-Rust 231 LV (Low VOC);
 - iii. PPG Protective and Marine Coatings, Amerlock 2 VOC or 400 VOC;
 - iv. Sherwin Williams Macropoxy 5500 LT; or
 - v. Tnemec Series L69F.
 - e. Finish Coats: Apply two coats, each with an 8 mil dry-film thickness, to achieve the total dry-film thickness. The coating material shall be the same material as the prime coat.

G. Coating System for Metal in Contact with Concrete

1. System No. E-1 -- Aluminum and Galvanized Surface in Concrete
- a. Type: Low VOC epoxy coating. A total dry-film consisting of the combined thickness of both a prime coat and finish coat is described herein. The total dry-film thickness of this system shall be 15 mils.
 - b. Service Conditions: Shall be used to coat areas including, but not limited to, gates, stairs, or structural members in contact with concrete.

- c. Surface Preparation: Apply synthetic resin wash primer (phosphoric acid or vinyl butyral acid) to surface. Surface preparation shall comply with SSPC SP-1.
- d. Prime Coat: Apply to a dry-film thickness of 5 mils. Approved manufacturers include:
 - i. Carboline Carboguard 890 VOC;
 - ii. International/Devoe Bar-Rust 231 LV (Low VOC);
 - iii. PPG Protective and Marine Coatings, Amerlock 2 VOC or 400 VOC;
 - iv. Sherwin Williams Macropoxy 646-100; or
 - v. Tnemec Series L69F.
- e. Finish Coats: Apply two coats, each with a 5 mil dry-film thickness, to achieve the total dry-film thickness. The coating shall be the same material as the prime coat.

H. PVC and FRP Pipe Coating System

- 1. System No. F-1 -- PVC and FRP Pipe, Atmospheric Weathering Environment
 - a. Type: Low VOC Aliphatic Polyurethane with low VOC epoxy-polyamide primer. A total dry-film consisting of the combined thickness of both a prime coat and finish coat is described herein. The total dry-film thickness of this system shall be 6 mils.
 - b. Service Conditions: Shall be used to coat PVC or FRP piping exposed to atmospheric elements and weathering.
 - c. Surface Preparation: Surfaces shall be cleaned and dried prior to application of coating.
 - d. Prime Coat: Apply one coat to a dry-film thickness of 3 mils. Approved manufacturers include:
 - i. Carboline Carboguard 890 VOC;
 - ii. International/Devoe BarRust 231;
 - iii. PPG Protective and Marine Coatings, Amerlock 2 VOC or 400 VOC;
 - iv. Sherwin Williams Macropoxy 646-100; or
 - v. Tnemec Series 135 Chembuild with low VOC thinner or L69 Epoxoline.
 - e. Finish Coat: Apply one coat to a dry-film thickness of 3 mils to achieve the total dry-film thickness. Approved manufacturers include:
 - i. Carboline Carboguard 134 MC;
 - ii. International/Devoe Devthane 379;
 - iii. PPG Protective and Marine Coatings, Amersfield VOC;
 - iv. Sherwin Williams Hi-Solids Polyurethane 100; or
 - v. Tnemec Series 1095 Endura-Shield.

I. Valve Coating System

1. System No. G-1 -- Surface of Ferrous-Metal Valves
 - a. Type: Thermosetting powdered epoxy coating.
 - b. Service Conditions: Shall be used to coat interior surfaces of ferrous metal valves, excluding seating areas and bronze and stainless steel pieces.
 - c. Surface Preparation: Protuberances which may produce pinholes in the coating shall be removed. Sharp edges shall be rounded. Surface contaminants which may prevent bonding of the coating shall be removed. Surface preparation shall comply with SSPC SP-5.
 - d. Coating: Apply to a total dry-film thickness of 12 mils in accordance with manufacturer's recommendation. Approved manufacturers include:
 - i. 3M Scotchkote 134; or
 - ii. Resicoat R4-ES.

2. System No. G-2 -- Surfaces of Ferrous-Metal Valves (Alternative)
 - a. General: This is an alternative to System No. G-1 when specified in the technical specifications.
 - b. Type: Two part low VOC epoxy-polyamide coating. A total dry-film consisting of the combined thickness of both a prime coat and finish coat is described herein. The total dry-film thickness of this system shall be 15 mils.
 - c. Service Conditions: Shall be used to coat interior surfaces of ferrous metal valves, excluding seating areas and bronze and stainless steel pieces.
 - d. Surface Preparation: Protuberances which may produce pinholes in the coating shall be removed. Sharp edges shall be rounded. Surface contaminants which may prevent bonding of the coating shall be removed. Surface preparation shall comply with SSPC SP-10.
 - e. Prime Coat: Apply to a dry-film thickness of 5 mils in accordance with manufacturer's recommendation. Approved manufacturers include:
 - i. International/Devoe 233 H LV (Low VOC);
 - ii. PPG Protective and Marine Coatings, Amerlock 2 VOC or 400 VOC;
 - iii. Sherwin Williams Macropoxy 646-100; or
 - iv. Tnemec Series L140F Pota Pox.
 - f. Finish Coats: Apply two coats, each with a 5 mil dry-film thickness, to achieve the total dry-film thickness. The coating material shall be the same material as the prime coat.

PART 3- EXECUTION

A. General

1. Quality assurance procedures and practices shall be utilized to monitor all phases of surface preparation, application, and inspection throughout the duration of the project. Procedures or practices not specifically defined herein may be utilized provided they meet recognized and acceptable professional standards and are approved by the District.
2. Work accomplished in the absence of prescribed inspection may be required to be removed and replaced under the proper inspection, and the entire cost of removal and replacement, including the cost of all materials which may be furnished by the District and used in the work thus removed, shall be borne by the Contractor, regardless of whether the work removed is found to be defective or not. Work covered up without the authority of the District, shall, upon order of the District, be uncovered to the extent required, and the Contractor shall similarly bear the entire cost of accomplishing all the work and furnishing all the materials necessary for the removal of the covering and its subsequent replacement, as directed and approved by the District.
3. The District will make, or have made, such tests as it deems necessary to assure the work is being accomplished in accordance with the requirements of the Contract Documents. Unless otherwise specified, the cost of such testing will be borne by the District. In the event such tests reveal non-compliance with the requirements of the Contract Documents, the Contractor shall bear the cost of such corrective measures deemed necessary by the District, as well as the cost of subsequent retesting and re-inspection. Tests shall not constitute an acceptance of any portion of the work, nor relieve the Contractor from compliance with the terms of the Contract Documents.
4. Application: No coating shall be applied under the following conditions:
 - a. When the surrounding air temperature or the temperature of the surface to be coated or painted is below 55 °F for epoxy coatings, below 45 °F for epoxy low temperature cure coatings, or above 125 °F for all materials;
 - b. To wet or damp surfaces or in rain, snow, fog or mist;
 - c. When the air temperature is less than 5 °F above the dewpoint;
 - d. When it is expected the air temperature will drop below 55 °F for epoxy coating; or 45 °F. for epoxy low temperature cure coatings or less than 5 °F above the dewpoint within two hours after application of coatings or paints.
 - i. Dewpoint shall be measured by use of an instrument such as a Sling Psychrometer manual or electronic in conjunction with U.S. Department of Commerce Weather Bureau Psychrometric Tables or equivalent. If dehumidification is used, equipment must run continuously during all phases of the contract, except disinfection phase. If above conditions are prevalent, coating application shall be delayed or postponed until conditions are favorable. The day's

application shall be completed in time to permit the film sufficient drying time prior to damage by atmospheric conditions.

5. **Overspray and Dust Control:** The Contractor shall conduct all operations so as to confine abrasive blasting debris and coating and paint overspray to within the bounds of the site. The Contractor shall take all precautions necessary to prevent adverse off-site consequences of application operations. Any complaints received by the District relating to any such potential off-site problems will be immediately delivered to the Contractor. The Contractor shall immediately halt blast cleaning or application work and shall take whatever corrective action is required to mitigate any such problems. All costs associated with protection of off-site properties and/or correction of damage to property as a result of blast cleaning or application operations shall be borne directly by the Contractor at no additional expense to the District.
6. **Inspection Devices:** Contractor shall furnish, until final acceptance of coatings and paints, inspection devices in good working condition for detection of holidays and measurement of dry-film and wet-film thickness. Contractor shall also furnish U.S. Department of Commerce, National Bureau of Standards certified thickness calibration plates to test accuracy of thickness gauges. Dry film thickness gauges and holiday detectors shall be available at all times until final acceptance of application. Inspection devices shall be operated by, or in the presence of the District with location and frequency basis determined by the District. The District is not precluded from furnishing their own inspection devices and rendering decisions based solely upon their tests.
7. All surface preparation, coating and paint application shall conform to applicable standards of the Society for Protective Coating, the District and the manufacturer's printed instructions. Material applied prior to approval of the surface, by the District, shall be removed and reapplied to the satisfaction of the District at the expense of the Contractor.
8. All work shall be accomplished by skilled craftsmen qualified to accomplish the required work in a manner comparable with the best standards of practice. Resumes of personnel to be used on the project shall be made available upon request. Continuity of personnel shall be maintained and transfers of key personnel shall be coordinated with the District.
9. The Contractor shall provide a supervisor to be at the work site during cleaning and application operations. The supervisor shall have the authority to sign change orders, coordinate work and make other decisions pertaining to the fulfillment of the Contract Documents.
10. The Contractor's equipment shall be designed for application of materials specified and shall be maintained in first class working condition. Compressors shall have suitable traps and filters to remove water and oils from the air. Blotter test shall be accomplished at each start-up period and as deemed necessary by the District. Contractor's equipment shall be subject to approval of the District. This approval does not relieve the Contractor's responsibility for the safe operation of the equipment or its performance.
 - a. Cleanliness of compressed air supply shall be verified daily, and as deemed necessary by the District Representative, by directing a stream of air, without abrasive, from the blast nozzle onto a white blotter or cloth for

twenty seconds. If oil or water appears on the blotter or cloth, all traps and separators shall be blown down until two subsequent twenty-second tests show no further oil or water.

11. Because of presence of moisture and possible contaminants in the atmosphere, care shall be taken to ensure previously coated or painted surfaces are protected or re-cleaned prior to application of subsequent coat(s). Methods of protection and re-cleaning shall be approved by the District.
 - a. The project is subject to intermittent shutdown if, in the opinion of the District, cleaning and application operations are creating a localized condition detrimental to ongoing facility activities, personnel or adjacent property.
 - b. In the event of emergency shutdown by the District, Contractor shall immediately correct deficiencies. All additional costs created by shutdown shall be borne by Contractor.

B. Surface Preparation

1. General: Sandblast or prepare only as much surface area as can be coated in one day. All sharp edges, burrs, and weld spatter shall be removed. Epoxy-coated pipe that has been factory coated shall not be sandblasted.
2. SSPC Specifications: Wherever the words "solvent cleaning", "hand tool cleaning", "wire brushing", "blast cleaning", or similar words are used in these specifications or in paint manufacturer's specifications, they shall be understood to refer to the applicable SSPC (Society for Protective Coatings, Surfaces Preparation Specifications, ANSI A159.1) specifications listed below:

SP-1	Solvent Cleaning
SP-2	Hand Tool Cleaning
SP-3	Power Tool Cleaning
SP-5	White Metal Blast Cleaning
SP-6	Commercial Blast Cleaning
SP-7	Brush-Off Blast Cleaning
SP-8	Pickling
SP-10	Near White Blast Cleaning

3. The Contractor shall provide suitable enclosure, exhaust system, and bag house for sandblasting operations to prevent violations of applicable air quality requirements.
4. Surface preparation shall be based upon comparison with: "Pictorial Surface Preparation Standards for Painting Steel Surfaces", SSPC-Vis 1, ASTM Designation D2200, NACE Standard TM-01-70. Anchor profile for prepared surfaces shall be measured by using a non-destructive instrument such as a K-T Surface Profile Comparator or Testex Press-O-Film System. Temperature and dewpoint requirements shall apply to all surface preparation operations.
5. Dust, dirt, oil, grease or any foreign matter which will affect the adhesion or durability of the finish must be removed by washing with clean rags dipped in an approved commercial cleaning solution, rinsed with clean water and wiped dry

with clean rags. Abrasive blasting nozzles shall be equipped with "deadman" emergency shut-off nozzles. Blast nozzle pressure shall be a minimum of 95 psi and shall be verified by using an approved nozzle pressure gage at each start-up period or as directed by the District. Number of nozzles used during all blast cleaning operations must be sufficient to ensure timely completion of project, subject to designation and approval by the District.

6. All blast hose connections shall be tethered and secured to prevent separation during blast cleaning operations, and shall be taped with duct tape prior to pressurizing. All taped connections shall be visually inspected for leaks within five minutes after start of blast cleaning operations and at the end of blast cleaning operations. Leaking connections shall be immediately repaired to prevent further damage.
7. Particle size of abrasives used in blast cleaning shall be that which will produce a 2 mil surface profile or in accordance with recommendations of the manufacturer of the specified coating system to be applied, subject to approval of the District.
8. Abrasive used in blast cleaning operations shall be new, washed, graded and free of contaminants which would interfere with adhesion of coatings and shall not be reused unless specifically approved by the District. Abrasives shall be certified for unconfined dry blasting pursuant to the California Administrative Code, Section 92520 of Subchapter 6, Title 17, and shall appear on the current listing of approved abrasives. Invoices or load sheets confirming above shall be submitted to the District upon request.
9. During blast cleaning operations, caution shall be exercised to ensure existing coatings and paint are not exposed to abrasion from blast cleaning.
10. Blast cleaning from rolling scaffolds shall only be accomplished within confines of interior perimeter of scaffold. Reaching beyond limits of perimeter will be allowed only if blast nozzle is maintained in a position which will produce a profile acceptable to the District.
11. The Contractor shall keep the area of his work in a clean condition and shall not permit blasting materials to accumulate as to constitute a nuisance or hazard to the prosecution of the work or the operation of the existing facilities. Spent abrasives and other debris shall be removed at the Contractor's expense as directed by the District.
12. Blast cleaned and coated/painted surfaces shall be cleaned prior to application of specified coatings/paints via a combination of blowing with clean dry air, brushing/brooming and/or vacuuming as directed by the District. Air hose for blowing shall be at least 1/2-inch in diameter and shall be equipped with a shut-off device. Tests on surfaces of abrasively blast cleaned steel shall be accomplished to detect oil and other contaminants which might be deposited on surfaces. This will include chemical tests or ultraviolet (black light) tests, as required.

C. Application

1. Multiple-component coatings shall be prepared using all the contents of each component container as packaged by the paint manufacturer. Partial batches shall

not be used. Multiple-component coatings that have been mixed beyond their pot life shall not be used. Small quantity kits for touch-up painting and for painting other small areas shall be provided. Only the components specified and furnished by the paint manufacturer shall be mixed. For reasons of color or otherwise, additional components shall not be intermixed even within the same generic type of coating.

2. Application of the first coat shall follow immediately after surface preparation and cleaning within an eight hour working day. Any cleaned areas not receiving first coat within an eight hour period shall be re-cleaned prior to application of first coat.
3. Coating and paint application shall conform to the requirements of the Society for Protective Coating Paint Application Specification SSPC-PA1, latest revision, for "Shop, Field and Maintenance Painting," the District, the manufacturer of the coating and paint materials printed literature and as specified herein.
4. All coating components shall be mixed in exact proportions specified by the manufacturer. Care shall be exercised to ensure all material is removed from containers during mixing and metering operations.
5. All coatings shall be thoroughly mixed, utilizing an approved slow-speed power mixer until all components are thoroughly combined and are of a smooth consistency.
6. Thinning shall only be permitted as recommended by the manufacturer and approved by the District and shall not exceed limits set by applicable regulatory agencies.
 - a. If the Contractor applies any materials which have been modified or thinned to such a degree as to cause them to exceed established VOC levels, the Contractor shall be responsible for any fines, costs, remedies, or legal action and costs that may result.
7. Each application of coating or paint shall be applied evenly, free of brush marks, sags, runs and no evidence of poor workmanship. Care should be exercised to avoid lapping on glass or hardware. Coatings and paints shall be sharply cut to lines. Finished surfaces shall be free from defects or blemishes.
8. Protective coverings or drop cloths shall be used to protect floors, fixtures, equipment, prepared surface and applied coatings or paints. Care shall be exercised to prevent coating or paint from being spattered onto surfaces which are not to be coated or painted. Surfaces from which such material cannot be removed satisfactorily shall be refinished as required to produce a finish satisfactory to the District.
9. All welds and irregular surfaces specified by the District shall receive a brush coat of the specified product prior to application of each complete coat. Coating shall be brushed in multiple directions to ensure penetration and coverage, as directed by the District. Care shall be exercised to ensure dry film thickness of coatings and paints do not exceed the maximum thickness allowed by the manufacturer of the specific product being applied.

10. At conclusion of each day's blast cleaning and coating operations, a 6-inch wide strip of blast cleaned substrate shall remain uncoated to facilitate locating point of origin for successive day's blast cleaning operations.
11. Epoxy coated surfaces or other multi-component materials exposed to excessive sunlight or an excessive time element beyond manufacturer's recommended recoat cycle, shall be scarified by Brush-Off Blast Cleaning (SSPC SP-7) or methods approved by the District Representative, prior to application of additional coating or paint. Scarified coating or paint shall have sufficient depth to assure a mechanical bond of subsequent coat.
12. When two or more coats are specified, where possible, each coat shall contain sufficient approved color additive to act as an indicator of coverage or the coats must be of contrasting color.
13. Care shall be exercised during spray operations to hold the spray nozzle perpendicular and sufficiently close to surfaces being coated, to avoid excessive evaporation of volatile constituents and loss of material into the air or the bridging of cracks and crevices. Reaching beyond limits of scaffold perimeter shall not be permitted. All overspray identified by the District shall be removed by hand or pole sanding prior to application of subsequent coat.

D. Surfaces Not To Be Painted

Unless noted otherwise, the following surfaces shall not be painted and shall be fully protected when adjacent areas are painted.

1. Mortar-coated pipe and fittings
2. Stainless Steel surfaces (excluding stainless steel bolts, nuts, and washers which shall be painted)
3. Aluminum guardrails and handrails
4. Galvanized pipe supports and ladders
5. Nameplates and grease fittings
6. Aluminum grating
7. Brass and copper pipe

E. Protection of Surfaces Not To Be Painted

Hardware, lighting fixtures, switch plates, aluminum surfaces, machined surfaces, couplings, shafts, bearings, nameplates on machinery, and other surfaces not intended to be painted shall be removed, masked, or otherwise protected. Drop cloths shall be provided to prevent paint materials from falling on or marring adjacent surfaces. Working parts of mechanical and electrical equipment shall be protected from damage during surface preparation and painting process. Openings in motors shall be safely masked to prevent paint and other materials from entering the motors. All masking materials shall be completely removed and surfaces cleaned at completion of painting operations.

F. Color Schedule

1. Definitions:

At Grade: Facilities that are flush with streets, sidewalks, parking lots, green belts or graded areas. This also includes pipelines and other facilities that are protruding through and are located above finished grade, out of doors and not enclosed by a shelter, cover, vault or housing.

Enclosed: Pipeline and other facilities that are located above or below grade and are enclosed within a shelter, covers, or vaults.

N/A: Not Applicable.

I.D. Mark: System identification marker as described herein. The I.D. Mark shall identify the system of which the facility is a part.

2. Color Guidelines: Unless noted otherwise, surfaces that are to be coated and that require a color designation for any of the following uses, shall be coated to match the colors listed below. Final color selection shall be determined by District Representative.

3. Potable Water System:

Facility	Enclosed	At Grade
Airvac, Blow Off, & Bottom Drain Assemblies	Dark Blue	Olive Light w/I.D. Mark
Airvac Covers (metallic only)	N/A	Olive Light w/I.D. Mark
Check Valves	Olive Light	Olive Light
Electric Motors	Olive Light	Olive Light w/I.D. Mark
Electrical Enclosures	Factory Finish	Olive Light or Factory Finish
Fire Hydrants	N/A	Safety Yellow
Piping	Olive Light w/I.D. Mark	Olive Light w/I.D. Mark
Pressure Vessels	Olive Light w/I.D. Mark	Olive Light w/I.D. Mark
Pump & Pump Bases	Olive Light	Olive Light
Reduced Pressure Principle Device (RPPD) *	Olive Light	Olive Light
Valves (all types)	Olive Light	Olive Light
Valve Can Lids: Normally Open Normally Open (for fire hydrants) Normally Closed (at zone breaks)	N/A N/A N/A	Safety Yellow Dark Blue Safety Red

* Final color selection shall be determined by the municipality or fire authority having jurisdiction.

4. Recycled Water System:

Facility	Enclosed	At Grade
Airvac, Blow Off, & Bottom Drain Assemblies	Purple	Olive Light w/I.D. Mark
Airvac Covers (metallic only)	N/A	Olive Light w/I.D. Mark
Electric Motors	Olive Light	Olive Light
Electrical Enclosures	Factory Finish	Olive Light or Factory Finish
Hydrants	N/A	Purple
Piping	Olive Light w/I.D. Mark	Olive Light w/I.D. Mark
Pressure Vessels	Olive Light w/I.D. Mark	Olive Light w/I.D. Mark
Pump & Pump Bases	Olive Light	Olive Light
Valves (all types)	Olive Light	Olive Light
Valve Can Lids: Normally Open Normally Closed (at zone breaks)	N/A N/A	Purple Safety Red

5. Sewer Collection System:

Facility	Enclosed	At Grade
Airvac Assemblies	Safety Green	Olive Light w/I.D. Mark
Airvac Covers (metallic only)	N/A	Olive Light w/I.D. Mark
Electric Motors	Olive Light	Olive Light
Electrical Enclosures	Factory Finish	Olive Light or Factory Finish
Manhole Covers & Frames	Black	Black
Piping	Olive Light w/I.D. Mark	Olive Light w/I.D. Mark
Pump & Pump Bases	Olive Light	Olive Light
Valves (all types)	Olive Light	Olive Light
Valve Can Lids	N/A	Safety Green

6. Raw Water System:

Facility	Enclosed	At Grade
Airvac, Blow Off, & Bottom Drain Assemblies	Light Blue	Olive Light w/I.D. Mark
Airvac Covers (metallic only)	N/A	Olive Light w/I.D. Mark
Electric Motors	Olive Light	Olive Light
Electrical Enclosures	Factory Finish	Olive Light or Factory Finish
Hydrants	N/A	Light Blue
Piping	Olive Light w/I.D. Mark	Olive Light w/I.D. Mark
Pressure Vessels	Olive Light w/I.D. Mark	Olive Light w/I.D. Mark
Pump & Pump Bases	Olive Light	Olive Light
Valves (all types)	Olive Light	Olive Light
Valve Can Lids	N/A	Light blue

7. Non-Reclaimable Waste System:

Facility	Enclosed	At Grade
Airvac, Blow Off, & Bottom Drain Assemblies	Brown	Olive Light w/I.D. Mark
Airvac Covers (metallic only)	N/A	Olive Light w/I.D. Mark
Electric Motors	Olive Light	Olive Light
Electrical Enclosures	Factory Finish	Olive Light or Factory Finish
Piping	Olive Light w/I.D. Mark	Olive Light w/I.D. Mark
Pressure Vessels	Olive Light w/I.D. Mark	Olive Light w/I.D. Mark
Pump & Pump Bases	Olive Light	Olive Light
Valves (all types)	Olive Light	Olive Light
Valve Can Lids	N/A	Brown

8. Test station box lids for cathodic protection shall be painted safety orange. Refer to Section 16640, Cathodic Protection and Joint Bonding for test box specifications.

9. Identification (I.D.) Mark:

Certain facilities listed above to be coated shall have an identification system applied by the Contractor at the District's direction.

Vault hatches (coated or uncoated) shall be identified with the IRWD initials and the system the facility serves (recycled water, raw water, potable water, sewer). The identification mark shall be able to stand up to traffic and not pose a tripping hazard.

Other facilities listed above that are to be coated and/or provided with an I.D. mark shall receive a District supplied identification decal that consists of the District's logo, phone number, system identification color, and the system the facility serves.

G. Field Touch Up of Shop-Applied Prime Coats

1. Organic Zinc Primer: Surfaces that are shop primed with inorganic zinc primers shall receive surface preparation and a field touchup of organic zinc primer to cover all scratches or abraded areas. Organic zinc primer system shall have a minimum volume solids of 70%. Finish coats shall be in accordance with System No. C-1. Organic zinc primer shall be manufactured by the prime coat and finish coat manufacturer.
2. Other Surfaces: Other surfaces that are shop primed shall receive surface preparation and a field touchup of the same primer used in the original prime coat.

H. Dry-Film & Wet-Film Thickness Testing

1. Coating Thickness Testing: Coating thickness specified herein is "dry-film thickness" in mils. Mil thicknesses specified are minimums. Coating thickness specified for steel surfaces shall be measured with a magnetic-type dry-film thickness gage. Dry-film thickness gage shall be provided as manufactured by Elcometer, Mikrotest, Positector, or Quanix.

For System No. B-4 only, wet-film thickness testing may be used. Wet-film thickness gage shall be provided as manufactured by Tinker and Razor. Coating thickness specified herein is "wet-film thickness" in mils. Mil thicknesses specified are minimums.

Each coat shall be checked for the correct dry-film thickness. Measurement shall not be made until a minimum of eight hours after application of the coating. Non-magnetic surfaces shall be checked for coating thickness by micrometer measurement of cut and removed coupons. Contractor shall repair coating at all locations where coupons are removed.

2. Holiday Testing: The finish coat (except zinc primer and galvanizing) shall be tested for holidays and discontinuities using only the specified high voltage instrument, with a wire brush electrode, at a minimum of 100 volts per mil in accordance with AWWA C203, latest revision. Detector shall be provided as manufactured by Tinker and Razor, Models AP and AP-W holiday detectors.
3. Repair: If a surface has an improper finish color, insufficient film thickness, or holidays, the surface shall be cleaned and top-coated with the specified paint material to obtain the specified color and coverage. Visible areas of chipped, peeled, or abraded paint shall be hand or power-sanded, feathering the edges. The areas shall then be primed and finish coated in accordance with the specifications. Work shall be free of runs, bridges, shiners, laps, or other imperfections.

END OF SECTION

SECTION 15040: INTERIOR INSPECTION FOR CEMENT-MORTAR LINED STEEL PIPE

PART 1 - GENERAL

A. Description

This section describes the inspection required for the acceptance and verification of cement-mortar lined steel pipe for diameters 4-inch through 30-inch and for other sections of pipe deemed not readily accessible for inspection personnel to enter the pipe.

B. Related Work Specified Elsewhere

1. Chlorination of Water Mains for Disinfection: 15041
2. Hydrostatic Testing of Pressure Pipelines: 15042
3. Installation of Pressure Pipelines: 15051
4. Cement Mortar Lined and Coated Steel Pipe: 15076
5. Cathodic Protection and Joint Bonding: 16640

C. Submittals

1. The Contractor shall submit video camera equipment cutsheets and product information for review and approval. For video inspection of potable water systems, the Contractor shall submit documentation that confirms the CCTV equipment is only used on potable water systems and is not used on other systems, such as, but not limited to, sewer, recycled water, or storm drain systems.
2. After completing the video inspection, the Contractor shall submit the inspection video and documentation to the District

D. Interior Joint Inspection

1. After backfilling and compacting around the pipeline and prior to testing and disinfecting the pipeline, the Contractor shall obtain the services of an independent third party to perform a closed circuit television (CCTV) inspection to document the condition within the pipeline, and to verify the condition of the lining after installation for all CML pipe with diameters of 4-inches up to and including 30-inches in diameter. Payment for the video inspection shall be included in the unit price for the pipeline.
2. All video inspections shall be recorded on a CD or DVD. All original video CD's, DVD's, log sheets, notes and reports shall be submitted to and become the property of the District.
3. Any work found in non-compliance with the Contract Documents and rejected shall be repaired and re-televised at the Contractor's expense.

4. If the quality of the CD or DVD is deemed unacceptable by the District's representative, the pipeline shall be re-televised at no additional cost to the District.

PART 2 - MATERIALS

A. Ventilation for Confined Space Safety

The Contractor shall provide access points and ventilation for the video inspection of the interior of the pipeline. Ventilation shall be sufficient to permit entry for personnel if it is deemed necessary.

PART 3 - EXECUTION

A. General

1. CCTV Equipment:

- a. CCTV equipment shall include television cameras, a television monitor, cables, power sources and other equipment necessary to perform a video camera inspection.
- b. The camera shall have a rotating video camera lens system.
- c. Focal distance shall be adjustable through a range from 6-inches to infinity.
- d. The remote reading footage counter shall be accurate to less than 1-percent error over the length of the particular section of pipeline being inspected.
- e. The camera and television monitor shall produce a minimum 14 lines per 350-lines-per inch resolution.
- f. Video camera shall be mounted on a transporter or skid system.
- g. Lighting for the camera shall minimize reflective glare. Lighting and picture quality shall be suitable to provide a clean, in focus picture of the entire periphery of the pipeline.
- h. A padded seat that will accommodate at least one Inspector and one Engineer shall be located behind the TV operator in-line with the video monitor. This seat may be used by the Inspector and Engineer to monitor the video inspection.
- i. CCTV inspection shall be performed utilizing a camera and cable that is exclusively used for potable water applications.

2. Communications Equipment:

- a. Telephones, radios or other suitable means of communication shall be set up to ensure that adequate communication exists between members of the crew.

B. Field Inspection

1. CCTV Field Inspection: CCTV Field inspection shall be performed such that:
 - a. The camera shall be moved through the pipeline in one direction, no skipping or changing of directions will be allowed.
 - b. The camera shall move at a uniform rate, stopping when necessary, but in no case shall the television camera be pulled at a speed greater than 30 feet per minute.
 - c. The camera shall stop at each joint and the camera lens rotated to inspect each joint. All CML&C steel pipe joints shall have "mark numbers" on interior joints as well as exterior joints.
 - i. The operator shall focus on the joint and pan 360 degrees around the finished joint to verify that there are:
 - (a.) no gaps or voids in the lining;
 - (b.) smooth transitions of the cement mortar lining.

C. Inspection Documentation

1. Inspection Documentation:
 - a. Documentation shall consist of a color CD or DVD, log sheets and a written report detailing the condition found at the joints.
 - b. Distances shall correspond to the pipeline stationing shown on the plans.
 - c. The report shall note the time and date of video inspection, street name, pipeline station, direction of view, pipeline length, pipe section length, pipe size, pipe material, laterals, videotape number, counter number and a detailed logging of defects encountered.

END OF SECTION

SECTION 15041: CHLORINATION OF WATER MAINS, WELLS AND RESERVOIRS

PART 1 - GENERAL

A. Description

This section describes the disinfection of potable water mains, wells and well-head facilities, reservoirs, services, appurtenances, and connections by chlorination, in accordance with ANSI/AWWA B300, B301, C651, C652, and C654 and as specified herein.

B. Related Work Specified Elsewhere

Hydrostatic Testing of Pressure Pipelines: 15042

C. Submittals

The Contractor shall submit certification indicating the calcium hypochlorite or sodium hypochlorite to be used for disinfecting potable water mains, wells, and reservoirs meets the requirements of NSF 60.

D. Job Conditions

1. Discharge of chlorinated water into watercourses or surface waters is regulated by the National Pollutant Discharge Elimination System (NPDES).
2. The rate of flow and locations of discharges shall be scheduled in advance to permit review and coordination with District and cognizant regulatory authorities, including the following.
 - a. Orange County Flood Control District.
 - b. City in which the project is located.
3. Potable water shall be used for chlorination.
4. Requests for use of water from District waterlines shall be submitted 48 hours in advance.
5. Chlorination shall be performed prior to hydrostatic testing. See Part 3, Paragraph A-9 for concurrent hydrostatic testing and chlorination of smaller diameter pipelines.

PART 2 - MATERIALS

A. Liquid Chlorine Solution

Liquid chlorine solution shall be in accordance with the requirements of ANSI/AWWA B301, shall be NSF 60 certified, and shall be injected with a solution feed chlorinator and a water booster pump or a sufficiently pressurized source of water to provide an adequate flow to inject and disperse the chlorine solution.

B. Calcium Hypochlorite (Dry)

Calcium Hypochlorite shall be in accordance with the requirements of ANSI/AWWA B300, shall be NSF 60 certified, and shall be dissolved in water to a known concentration in a container and pumped into the pipeline at a measured rate.

C. Sodium Hypochlorite (Solution)

Sodium Hypochlorite shall be in accordance with the requirements of ANSI/AWWA B300, shall be NSF 60 certified, and be diluted in water to desired concentration and pumped into the pipeline at a measured rate.

D. Calcium Hypochlorite Tablets and Adhesive

1. Chlorine Content: The tablets shall have an average weight of 5 grams each and shall contain not less than 70% of available chlorine.
2. Adhesive: Adhesive shall be a type that will not impart taste, odor, or detrimental compounds to the water supply.
3. Storage: Proper care shall be taken to store calcium hypochlorite tablets in tightly closed containers where they will not be accessible to children or unauthorized persons.

E. Chlorine Residual Test Kit

For measuring chlorine concentration, a medium range, drop count, titration kit or an orthotolidine indicator comparator with wide range color discs shall be used. The kit shall be capable of determining chlorine concentration in the range 1.0 to 25 mg/L. Test kits shall be Hach Chemical or Hellige. An adequate number of kits shall be maintained by the Contractor in good working order and available for immediate test of residuals at points of sampling.

PART 3 - EXECUTION

A. Pipelines

1. General: Before being placed into service, all pipelines and appurtenances shall be chlorinated in accordance with AWWA C651 and as described herein. Pipelines with a diameter of 10-inches or less shall be disinfected by either direct chlorine solution injection or by use of calcium hypochlorite tablets. Pipelines with a diameter of 12-inches and larger shall be disinfected by direct chlorine solution injection. Steel pipelines shall be disinfected by continuous feed chlorine solution injection. Bacteriological testing after disinfection shall be performed by the District.
2. Chlorination Contractor: Chlorination shall be performed by a disinfection specialist. Chlorination shall be in accordance with the instructions of the chlorinator manufacturer and be performed by a Class A or C-34 licensed contractor.
3. Groundwater: In the event groundwater is encountered and it is impossible to prevent its entrance into the mains, or the mains are not free from dirt, they shall be

thoroughly flushed prior to disinfection. Disinfection shall be by continuous feed chlorine solution injection.

4. Services: Every service connection served by a main being disinfected shall be tightly shutoff at the curb stop before water is applied to the main. Care shall be taken to expel all air from the main and services during the filling operation.
5. Pipeline Flushing: Pipe flushing shall be performed in accordance with Section 15042, Hydrostatic Testing of Pressure Pipelines.
6. Continuous Feed – Chlorine Solution Injection Method:
 - a. Chlorine solution shall be applied by means of a vacuum-operated chlorinator and a booster pump or a sufficiently pressurized source of water to provide an adequate flow to operate the eductor system and properly disperse the chlorine solution. Direct-feed chlorinators, which operate from gas pressure in the chlorine cylinder without a vacuum regulator, shall not be used for application of a chlorine solution.
 - b. Chlorine solution shall be applied at the beginning of the section to be chlorinated and shall be injected through a corporation stop, a hydrant, or other approved connection to ensure treatment of the entire system being disinfected. All required corporation stops and other plumbing materials necessary for chlorination or flushing of the main shall be installed by the Contractor.
 - c. Potable water shall be introduced into the pipeline at a constant measured rate. Chlorine solution shall be injected into the potable feed water at a measured rate. The two rates shall be proportioned so that the chlorine concentration in the pipeline is maintained at a minimum concentration of 50 mg/L to 100 mg/L, with a chlorine residual of 25 mg/L after 24 hours in the pipe. The concentration at points downstream shall be checked periodically during the filling to confirm that sufficient chlorine is being added.
7. Disinfection by Calcium Hypochlorite Tablets: The use of calcium hypochlorite tablets will be permitted in pipe sizes 4- through 10-inches only when directed by the District Representative. The tablets shall be attached by means of an approved adhesive to the inside top of the lengths of pipe as they are being laid. The amount of adhesive shall be limited to the smallest practicable amount applied to one side of the tablet only.

The following table shows the number of tablets to be used per length of pipe of various sizes to provide the required chlorine residual:

Inside Diameter of Pipe (Inches)	No. of 5g. Hypochlorite Tablets Per Length of Pipe		
	10'	18' & 20'	40'
4	1	1	1
6	1	1	2
8	1	2	4
10	2	3	5

8. Disinfection of Valves and Appurtenances: During the period that the chlorine solution is in the section of pipeline, valves shall be opened and closed to obtain a chlorine residual at hydrants and other pipeline appurtenances. Care shall be taken to ensure that no chlorinated water enters any active pipeline.
9. Concurrent Testing (for Pipelines with Diameter of 10-inches or Less): Disinfecting mains and appurtenances, and hydrostatic testing may run concurrently for the required 24-hour test period. In the event there is leakage and repairs are necessary, disinfection of the pipeline shall be repeated by injection of chlorine solution into the line as provided in this section.
10. Confirmation of Residual: After the chlorine solution applied by the continuous feed method has been retained in the pipeline for 24 hours, samples shall be taken at air valves and other points of access to confirm that a chlorine residual of 25 mg/L minimum exists along the pipeline.
11. Pipeline Flushing: After confirming the chlorine residual, excess chlorine solution shall be flushed from the pipeline until the chlorine concentration in the water leaving the pipe is within 0.5 mg/L of the replacement water. Once flushing is complete the water in the pipeline shall remain dormant for 24-hours to reduce turbidity levels.
12. Water Quality Samples and Testing: The Contractor shall provide adequate and convenient means for the District Representative to collect an appropriate number of water samples for each segment of pipeline tested. A bacteriologic and physical quality test will be performed by the District to demonstrate the absence of coliform organisms in each separate section of the pipeline after chlorination and refilling.
13. Bacteriological Tests: On two consecutive days, bacteriological samples shall be taken and submitted to the District for examination. Samples shall be tested by the District for coliform bacteria and heterotrophic plate count. All coliform test results must be negative and heterotrophic plate counts must be less than 500 colonies/mL prior to placing the well into service.
14. Repetition of Procedure: If the initial or second chlorination fails to produce required residuals and bacteriologic results, chlorination and testing shall be repeated until two consecutive satisfactory results are obtained.
15. Test Facility Removal: After satisfactory disinfection, all temporary disinfection and test facilities shall be removed and restored to the satisfaction of the District Representative.

B. Wells, Well-Heads, and Pump Stations

1. General: The well and well head piping shall be disinfected as a complete unit. Adequate bracing shall be provided to resist thrust.
2. Depth of Disinfection: The well shall be disinfected to its full depth. A double capped, perforated pipe container filled with granular chlorine compound shall be moved up and down the entire water-filled casing and screen section until all the chlorine compound has dissolved.

3. Pump Column Disinfection: The pump column shall be washed with a chlorine solution, containing at least 12 percent chlorine, as the pump column is lowered into the well or pump can.
4. Mixing: After the well pump has been placed into position, it shall be turned on and off several times so as to thoroughly mix the disinfectant with the water in the well. The flow control valve shall be set at a pumping rate of 2 cfs. The pump shall be run until the water discharged has the odor of chlorine. This procedure shall be repeated several times at one-hour intervals.
5. Disinfection Time: After mixing, the well shall be allowed to stand without pumping for 24 hours.
6. Flushing: Well water shall be pumped to waste until the presence of chlorine is no longer detectable, as determined by testing for available chlorine residual using a test kit. Allow the well to stand without pumping for 24 hours. See Part 3, Execution, Sub-part D, Disposal of Chlorinated Water for other requirements.
7. Bacteriological Tests: On two consecutive days, bacteriological samples shall be taken and submitted to the District's laboratory for examination. Samples shall be tested by the District's laboratory for coliform bacteria and heterotrophic plate count. All coliform test results must be negative and heterotrophic plate counts must be less than 500 colonies/mL prior to placing the well into service.
8. Repetition of Procedure: If the laboratory analysis shows the water is not free of bacterial contamination, the disinfection procedure shall be repeated. Depending on the level of contamination, it may be necessary to use a higher concentration chlorine solution. The water shall then be re-tested. Two consecutive samples must pass the bacteriological tests before the well can be placed in service.

C. Reservoirs

1. General: The Contractor shall make all necessary provisions for conveying water from the District designated supply source to the points of use.
2. Facilities to be Disinfected: All hydraulic structures and appurtenant pressure piping shall be tested; those for potable water shall also be disinfected. In the case of a reservoir, testing and disinfecting operations shall be combined. Disinfection shall be accomplished by chlorination. All chlorinating and testing operations shall be done in the presence of the District Representative.
3. Scheduling: Disinfection operations shall be scheduled by the Contractor as late as possible during the contract time period so as to assure the maximum degree of sterility of the facilities at the time the work is accepted by the District.
4. Bacteriological Testing: Bacteriological testing shall be performed by the District's laboratory. Results of the bacteriological testing shall be satisfactory to the State Department of Health or other appropriate regulatory agency. Passing tests on two consecutive days for heterotrophic plate count (<500 cfu/mL) and absence from coliform bacteria must be achieved prior to placing the reservoir into service.
5. Release of Disinfection Water: Prior to the Contractor releasing water from the reservoir and after the Contractor completes testing and disinfecting of the structure, the District shall approve the release of water.

6. Preliminary Cleaning and Flushing: Prior to both testing and disinfecting, all hydraulic structures shall be cleaned by thoroughly hosing down all surfaces with a high pressure hose and nozzle of sufficient size to deliver a minimum flow of 50 gpm. All water, dirt, and foreign material accumulated in this cleaning operation shall be discharged from the structure or otherwise removed.

7. Disinfection of Hydraulic Structures and Appurtenant Pipelines: All hydraulic structures, which store or convey potable water, shall be disinfected by chlorination. Chlorination of hydraulic structures shall be performed in accordance with the requirements of ANSI/AWWA C652.
 - a. Chlorination: A strong chlorine solution (about 200 mg/L) shall be sprayed on all interior surfaces of the structure. Following this, the structure shall be partially filled with water to a depth of approximately one foot. During the partial filling operation, a chlorine-water mixture shall be injected by means of a solution feed chlorinating device in such a way as to give a uniform chlorine concentration during the entire filling operation. The point of application shall be such that the chlorine solution will mix readily with the in-flowing water.

The dosage applied to the water shall be sufficient to provide a chlorine residual of at least 50 mg/L upon completion of the partial filling operation. Precaution shall be taken to prevent the strong chlorine solution from flowing back into the lines supplying the water. After the partial filling has been completed, sufficient water shall be drained from the lower ends of appurtenant piping to ensure filling the lines with the heavily chlorinated water.
 - b. Retention Period: Chlorinated water shall be retained in the partially filled structure and appurtenant piping long enough to destroy all non-spore-forming bacteria, and in any event, for at least 24 hours. After the chlorine-treated water has been retained for the required time, the free chlorine residual in the structure and appurtenant piping shall be at least 25 mg/L. All valves shall be operated while the lines are filled with the heavily chlorinated water.
 - c. Final Filling of Structure: After the free chlorine residual has been checked, and has been found to satisfy the above requirement, the water level in the structure shall be raised to its final elevation by addition of potable water. Before final filling is commenced, the concentration of heavily-chlorinated water remaining in the structure and piping shall, unless otherwise acceptable to the District's Representative, be sufficient to produce a free chlorine residual of between 1 and 2 mg/L when the water level is raised to its final elevation. After the structures have been filled, the strength of the chlorinated water shall be determined. If the free chlorine residual is less than one mg/L, an additional dosage shall be applied to the water in the structure. If the free chlorine residual is greater than 2 mg/L, the structure shall be partially emptied and additional potable water added. In no case shall water be released prior to the expiration of the required retention period.

8. Connections to Existing System: Where connections are to be made to an existing potable water system, the interior surfaces of all pipe and fittings used in making the connections shall be swabbed or sprayed with a one percent hypochlorite solution

before they are installed. Thorough flushing shall be started as soon as the connection is completed and shall be continued until all discolored water is eliminated.

D. Disposal of Chlorinated Water

1. Disposal to District's Sewage Collection System: Recycled water shall be disposed of into the District's sewage collection system. Unless noted otherwise in the Contract Documents, or directed by the District Representative, chlorinated water from potable or untreated water pipelines shall be disposed of into the District's sewage collection system.
2. Dechlorination Prior to Disposal: If discharge from potable or untreated water pipelines to the sewage collection system is not permitted, then chlorinated water shall be dechlorinated prior to disposal. Dechlorination shall be performed by a certified chlorination and testing company. Dechlorinated water shall have a total chlorine residual concentration of less than 0.1 mg/L.

END OF SECTION

SECTION 15042: HYDROSTATIC TESTING OF PRESSURE PIPELINES

PART 1 - GENERAL

A. Description

This section describes pressure and leakage testing of all pressure pipelines, in accordance with the Hydrostatic Testing section of ANSI/AWWA C600, C604/M11, C605, and C800, and as specified herein.

B. Related Work Specified Elsewhere

Chlorination of Water Mains, Wells and Reservoirs: 15041

C. Submittals

1. Shop drawings shall be submitted in accordance with the General Provisions and as specified herein.
2. Test bulkhead locations and design calculations, pipe attachment details, and methods to prevent excessive pipe wall stresses.

D. Job Conditions

1. For potable and untreated water pipelines, obtain and use only potable water for hydrostatic testing. For recycled water and sewage pipelines, obtain and use only recycled water for hydrostatic testing.
2. Submit request for use of District water to the District 48 hours in advance of filling the pipeline.
3. Hydrostatic testing shall be successfully completed before new pipelines are connected to existing District pipes and mains.

E. Testing Company

All testing shall be performed by independent testing companies with a Class A license, and/or who are certified and District-approved to perform the required pressure testing and disinfection. Testing companies will be required to provide the District Representative with certified testing results. The testing company shall provide gauges and meters which have been calibrated and certified at least quarterly.

PART 2 - MATERIALS

A. Test Bulkheads

Test bulkheads shall be designed and tested in accordance with Section VIII of the ASME Boiler and Pressure Vessel Code. Materials shall comply with Part UCS of said code. Bulkhead design pressure shall be at least 2.0 times the specified test pressure for the section of pipe containing the bulkhead. Stress shall be limited to 70% of yield strength of the bulkhead material at the bulkhead design pressure. Air-release and water drainage connections shall be included.

B. Manual Air-Release Valves

Temporary manual air-release valves shall be provided where necessary for pipeline test. The number and location of release valves shall be subject to the review and approval of the District Representative. The pipe outlet shall be constructed in the same manner as for a permanent air valve. After use, the connection shall be sealed with a blind flange, pipe cap, or plug in a manner and with the fittings satisfactory to the District Representative. All connections and exposed fittings which are installed shall be coated equivalently to the adjacent pipe and in accordance with the District specifications.

C. Water

The same water used for chlorination of the pipeline may be used to fill the line for testing.

PART 3 - EXECUTION

A. General

All labor, materials, tools, and equipment for testing shall be furnished by the Contractor. The test shall be conducted with valves in the test section open. Ends of each test section, open ends of pipes, valves, and fittings shall be suitably closed. Valves in the test section shall be operated during the test period.

B. Testing and Disinfection Sequence

The testing and disinfection sequence shall comply with Section 15041, Chlorination of Water Mains, Wells and Reservoirs.

C. Isolation of Test Pipe Section from Existing Pipelines

Test bulkheads, valves, connections to existing pipelines, and other appurtenances shall be located and installed in a manner to provide air gap separation between existing potable water pipelines and pipeline being tested.

D. Length of Test Section

The maximum test section length for pipe of 12 inches in diameter or smaller shall be 3,500 feet and for pipe larger than 12 inches in diameter the maximum test section length shall be 1 mile. Test bulkheads shall be provided where the distance between valves exceeds these limits.

E. Requirements Prior to Testing

1. Backfill: The pipe trench shall be backfilled with a minimum of 2½ feet of material.
2. Concrete Anchor and Thrust Blocks: All concrete anchor blocks shall be allowed to cure a sufficient time to develop the designed minimum strength before testing.
3. Mortar Lining: Steel pipelines shall not be tested before the mortar lining and coating on all of the pipe lengths in the line have attained an age of 14 days. Cement-mortar lined pipe shall not be filled with water until a minimum period of eight hours has elapsed after the last joint in any section has been made.

F. Field Test Procedure

1. Filling Rate: The pipeline shall be filled at a rate such that the average velocity of flow is no greater than 2 fps. At no time shall the maximum velocity of flow exceed 2 fps. The following table gives filling rates to provide 2 fps velocity for various pipe diameters.

FILLING RATES FOR 2 FPS VELOCITY	
Nominal Pipe Size (Inches)	Filling Rates to achieve velocity of 2 fps (gpm)
4	80
6	180
8	320
10	490
12	700
16	1,250
18	1,580
20	1,960
24	2,820
30	4,400
36	6,340
42	8,640
48	11,280
54	15,350
60	17,620
66	21,320

2. Air Removal: All air should be purged from the pipeline before checking for leaks or performing pressure tests on the system. To accomplish this, if air valves or hydrants or other outlets are not available at high points, taps shall be made to expel the air, and these taps shall be tightly plugged after testing.
3. Pressurization: After the pipeline has been filled and allowed to sit a minimum of 48 hours (72 hours for mortar-lined pipelines), the pressure in the pipeline shall then be pumped up to the specified test pressure. If a large quantity of water is required to increase the pressure during testing, entrapped air, leakage at joints, or a broken pipe may be suspected. If a large quantity of water is required to increase the pressure during the test, the test shall be discontinued until the source of issue is identified and corrected.
4. Flushing: Pipelines shall be flushed with water after hydrostatic testing and disinfection to remove dirt and debris. For domestic water and untreated water systems, potable water shall be used for flushing and for recycled water and sewage systems, recycled water shall be used for flushing. Flushing should be performed via the District flush-out assemblies constructed in accordance with IRWD Standard Drawing W-12. Velocities shall be sufficient to achieve a minimum of 3 fps velocity in the pipeline. Pipe shall be flushed for a minimum time period as calculated from the following formula.

$$T = 2/3 L$$

T = flushing time (seconds)
L = pipe length (feet)

G. Test Pressure and Allowable Leakage

1. The test pressure for hydrostatic testing shall be 50 psi above the design pressure of the pipeline with the minimum allowable test pressure being 200 psi. Test pressure readings shall be taken at the lowest point in the section of pipe being tested.
2. When the test pressure has been reached, pumping shall be discontinued until the pressure in the line has dropped 5 psi, at which time the pressure shall again be pumped up to the specified test pressure. This procedure shall be repeated until four hours have elapsed from the time the specified test pressure was first applied. At the end of the four-hour period, the pressure shall be pumped up to the test pressure for the last time.
3. The leakage shall be considered as the total amount of water pumped into the pipeline during the four-hour period, including the amount required in reaching the test pressure for the final time.
4. The following table indicates the leakage allowance for various sizes of pipe for various test pressures.

LEAKAGE ALLOWANCES		
Pipe Size (Inches)	Allowable Leakage for 200 psi Test Pressure (Gallons per four hours per 1,000 feet of pipe)	Allowable Leakage for 250 psi Test Pressure (Gallons per four hours per 1,000 feet of pipe)
4	0.38	0.43
6	0.57	0.64
8	0.76	0.85
10	0.96	1.07
12	1.15	1.28
16	1.53	1.71
18	1.72	1.92
24	2.29	2.56
30	2.87	3.20
36	3.44	3.85
42	4.01	4.49
48	4.59	5.13
54	5.16	5.77
60	5.73	6.41
66	6.31	7.05

5. PVC Force Mains and Pressure Pipelines
 - a. The required test pressure shall be maintained for the following specified durations by restoring it whenever it falls by an amount of 5 psi: pipe of 18 inches in diameter and smaller, 4 hours; over 18 inches to 36 inches in diameter, 8 hours; and over 36 inches in diameter, 24 hours.
 - b. For non-PVC pipe, a minimum of three days shall be allowed for the filled pipeline to soak and to release entrapped air. The test pressure shall be applied with a positive displacement pump. A snubber and dampener shall be provided between the pump and the pipeline to reduce instantaneous pressure pulses to 10% of the specified test pressure. Water shall be drawn from containers in which the volume of water can

be readily measured or through a positive displacement meter. The amount of water used to maintain the test pressure during the test period shall be considered the leakage. The allowable leakage shall be determined by the above "Leakage Allowances" table or the following formula:

$$L = \frac{ND(P)^{1/2}}{7400}$$

- L = the allowable leakage (gallons per hour)
- N = the number of rubber-gasketed pipe joints in the test section
- D = the inside pipe test diameter (inches)
- P = the pipe test pressure (psig), which is defined as the average of the highest and lowest test pressures in the pipe section being tested.

- c. Note the allowable leakage rate for pipeline sections with flanged, welded, and/or grooved-end joints shall be zero.

H. Repetition of Test

If the actual leakage exceeds the allowable leakage, the faulty work shall be located and corrected and the test repeated. The work shall be restored, and all damage resulting from leaks repaired. All visible leakage shall be eliminated.

I. Bulkhead and Test Facility Removal

After a satisfactory test, water shall be drained to the sewage collection system as needed to accommodate removal of test bulkheads and other test facilities, valves on bottom drains shall be closed, pipe coatings restored, and the pipeline refilled with water until the pipeline is placed into service.

END OF SECTION

SECTION 15043: LEAKAGE & INFILTRATION TESTING OF NON-PRESSURE PIPELINES

PART - 1 GENERAL

A. Description

This section describes the requirements and procedures for leakage and infiltration testing of gravity sewer systems, in accordance with ANSI/ASTM C828, Low Pressure Air Test of Vitrified Clay Pipelines.

B. Related Work Specified Elsewhere

1. Existing Facilities: 01045
2. Jacked Casing: 02315
3. Open Trench Casing: 02316
4. Installation of Gravity Sewer Pipelines: 02701

C. Testing

1. General: All tests shall be made in the presence of the District Representative.
2. Leakage: Each section of sewer between two successive manholes shall be tested for leakage and the leakage test shall be made on all sections of sewer.
3. Infiltration: The infiltration test shall be made where excessive groundwater is encountered.
4. Retesting: Even though a section may have previously passed the leakage or infiltration test, each section of sewer shall be tested subsequent to the last backfill compacting operation if, in the opinion of the District Representative, heavy compaction equipment or any of the operations of the Contractor or others may have damaged or affected the structural integrity or watertightness of the pipe, structure, and appurtenances.
5. Other Utilities: Official District tests will not be made until after all the other utilities have been installed and their trenches are compacted. A memorandum from the geotechnical consultant referencing all test results shall be turned in to the District representative.
6. Excessive Leakage or Infiltration: If the leakage or infiltration rate is greater than the amount specified, the pipe joints shall be repaired or, if necessary, the pipe shall be removed and relaid by the Contractor.
7. Acceptance: The sewer will not be accepted until the leakage or infiltration rate, as determined by test, is less than the maximum allowable.

8. Sewer Laterals: When sewer laterals are added after the sewer main has been constructed by connecting to a previously installed wye fitting or to a newly cut-in wye-branch fitting, the new sewer lateral shall be plugged at the sewer main by use of a test plug and air tested to the satisfaction of the District Representative.

PART 2 - MATERIALS

A. General

The Contractor shall furnish all equipment and materials required for testing.

B. Water for Testing Manholes

Recycled water shall be used for testing manholes as described herein.

PART 3 - EXECUTION

A. Air Test for VCP Gravity Sewers

1. Test Section: Each section of sewer between two successive manholes shall be tested by plugging all pipe outlets with suitable test plugs. All test plugs shall be secured in place to prevent movement or slippage.
2. Addition of Air: Air shall be slowly added until the internal pressure is raised to 4.0 pounds per square inch gage (psig). The compressor used to add air to the pipe shall have a blowoff valve set at 5 psig to ensure that at no time the internal pressure in the pipe exceeds 5 psig.
3. Internal Pressure: The internal pressure of 4 psig shall be maintained for at least two minutes to allow the air temperature to stabilize, after which the air supply shall be disconnected and the pressure allowed to decrease to 3.5 psig.
4. Minimum Time for Allowable Pressure Drop: The time in seconds that is required for the internal air pressure to drop from 3.5 psig to 2.5 psig shall be measured and the results compared with the minimum permissible pressure holding times indicated in the following tables.
5. Retest: If the pressure drop from 3.5 psig to 2.5 psig occurs in less time than specified, the pipe shall be repaired and, if necessary, replaced and relaid until the joints and pipe shall hold satisfactorily under this test.

AIR TEST TABLES

(courtesy of NATIONAL CLAY PIPE INSTITUTE)

MINIMUM HOLDING TIME IN SECONDS REQUIRED FOR PRESSURE TO DROP FROM 3½ TO 2½ PSIG

(FOR USE WHEN TESTING ONE DIAMETER ONLY)

LENGTH	PIPE DIAMETER (FOR USE WHEN TESTING ONE DIAMETER ONLY)													
	4	6	8	10	12	15	18	21	24	27	30	33	36	39
25	4	10	18	28	40	62	89	121	158	200	248	299	356	418
50	9	20	35	55	79	124	178	243	317	401	495	599	713	837
75	13	30	53	83	119	186	267	364	475	601	743	898	1020	1105
100	18	40	70	110	158	248	356	485	634	765	851	935	1020	1105
125	22	50	88	138	198	309	446	595	680	765	851	935	1020	1105
150	26	59	106	165	238	371	510	595	680	765	851	935	1020	1105
175	31	69	123	193	277	425	510	595	680	765	851	935	1020	1105
200	35	79	141	220	317	425	510	595	680	765	851	935	1020	1105
225	40	89	158	248	340	425	510	595	680	765	851	935	1020	1105
250	44	99	176	275	340	425	510	595	680	765	851	935	1020	1105
275	48	109	194	283	340	425	510	595	680	765	851	935	1020	1105
300	53	119	211	283	340	425	510	595	680	765	851	935	1020	1105
350	62	139	227	283	340	425	510	595	680	765	851	935	1020	1105
400	70	158	227	283	340	425	510	595	680	765	851	935	1020	1105
450	79	170	227	283	340	425	510	595	680	765	851	935	1020	1105
500	88	170	227	283	340	425	510	595	680	765	851	935	1020	1105
550	97	170	227	283	340	425	510	595	680	765	851	935	1020	1105
600	104	170	227	283	340	425	510	595	680	765	851	935	1020	1105
650	113	170	227	283	340	425	510	595	680	765	851	935	1020	1105

LENGTH OF 6" DIAMETER MAIN LINE IN FEET

LENGTH OF 4" LATERAL	25	50	75	100	125	150	175	200	225	250	275	300	400	500
25	14	24	34	44	54	64	74	84	94	103	113	123	163	168
50	19	29	39	48	58	68	78	88	98	108	118	128	166	167
75	23	33	43	53	63	73	83	92	102	112	122	132	164	165
100	28	37	47	57	67	77	87	97	107	117	127	136	162	163
125	32	42	52	62	72	81	91	101	111	121	131	141	160	162
150	36	46	56	66	76	86	96	106	116	125	135	145	159	161
175	41	51	61	70	80	90	100	110	120	130	140	150	157	159
200	45	55	65	75	85	95	105	114	124	134	144	153	156	158
225	50	59	69	79	89	99	109	119	129	139	149	151	154	157
250	54	64	74	84	94	103	113	123	133	143	149	150	153	156
275	58	68	78	88	98	108	118	128	138	146	147	149	152	155
300	63	73	83	92	102	112	122	132	142	145	146	147	151	154
350	72	81	91	101	111	121	131	140	141	143	144	145	149	152
400	80	90	100	110	120	130	136	138	139	141	142	143	147	150
450	89	99	109	119	129	132	134	136	138	139	141	142	145	149
500	98	108	118	126	129	131	133	135	136	138	139	140	144	147

MINIMUM HOLDING TIME IN SECONDS
REQUIRED FOR PRESSURE TO DROP
FROM 3½ TO 2½ PSIG

LENGTH OF 8" DIAMETER MAIN LINE IN FEET

LENGTH OF 4" LATERAL	25	50	75	100	125	150	175	200	225	250	275	300	400	500
25	22	40	57	75	92	110	128	145	163	180	198	216	223	224
50	26	44	62	79	97	114	132	150	167	185	202	218	220	221
75	31	48	66	84	101	119	136	154	172	189	207	214	217	219
100	35	53	70	88	106	123	141	158	176	194	209	211	214	216
125	40	57	75	92	110	128	145	163	180	198	206	207	211	214
150	44	62	79	97	114	132	150	167	185	201	202	204	209	212
175	48	66	84	101	119	136	154	172	189	197	199	201	206	210
200	53	70	88	106	123	141	158	176	192	194	197	199	204	208
225	57	75	92	110	128	145	163	180	189	192	194	196	202	206
250	62	79	97	114	132	150	167	183	186	189	191	193	200	204
275	66	84	101	119	136	154	172	181	184	187	189	191	198	202
300	70	88	106	123	141	158	174	178	181	184	187	189	196	200
350	79	97	114	132	150	166	170	174	177	180	183	185	192	197
400	88	106	123	141	157	162	166	170	174	176	179	181	189	194
450	97	114	132	148	154	159	163	167	170	173	176	178	186	191
500	106	123	140	146	151	156	160	164	167	170	173	175	183	189

LENGTH OF 8" DIAMETER MAIN LINE IN FEET

LENGTH OF 6" LATERAL	25	50	75	100	125	150	175	200	225	250	275	300	400	500
25	28	45	63	80	98	116	133	151	168	186	204	221	224	225
50	37	55	73	90	108	126	143	161	178	196	214	220	222	223
75	47	65	83	100	118	135	153	171	188	206	217	217	220	221
100	57	75	93	110	128	145	163	181	198	214	214	215	218	220
125	67	85	102	120	138	155	173	190	208	211	212	213	216	218
150	77	95	112	130	148	165	182	200	207	209	210	211	214	217
175	87	105	122	140	157	175	192	204	206	207	208	209	213	215
200	97	114	132	150	167	185	201	202	204	205	206	207	211	214
225	107	124	142	160	177	195	199	201	203	204	205	206	210	213
250	117	134	152	169	187	195	198	199	201	202	203	204	209	212
275	127	144	162	179	192	194	196	198	200	201	202	204	208	210
300	136	154	172	187	190	192	195	196	198	200	201	202	207	209
350	156	174	181	185	187	190	193	194	196	198	199	200	205	208
400	173	178	181	184	186	189	191	192	194	196	197	198	203	206
450	173	177	180	183	185	187	189	190	192	194	195	196	201	204
500	173	177	180	182	184	186	188	189	191	192	193	194	200	203

MINIMUM HOLDING TIME IN SECONDS
REQUIRED FOR PRESSURE TO DROP
FROM 3½ TO 2½ PSIG

LENGTH OF 10" DIAMETER MAIN LINE IN FEET

LENGTH OF 4" LATERAL	25	50	75	100	125	150	175	200	225	250	275	300	400	500
25	32	59	87	114	142	169	197	224	252	277	277	278	279	280
50	36	64	91	119	146	174	201	229	256	271	272	273	275	277
75	41	68	96	123	151	178	206	233	261	265	267	268	272	274
100	45	73	100	128	155	183	210	238	258	260	262	264	268	271
125	50	77	105	132	160	187	214	242	253	255	257	259	264	268
150	54	81	109	136	164	191	219	244	248	251	253	255	261	265
175	58	86	113	141	168	196	223	239	243	246	249	251	258	262
200	63	90	118	145	173	200	228	235	239	242	245	248	255	260
225	67	95	122	150	177	205	226	231	235	239	242	244	252	257
250	72	99	127	154	182	209	222	227	231	235	238	241	249	255
275	76	103	131	158	186	211	218	223	228	231	235	238	247	253
300	80	108	135	163	190	208	214	220	224	228	232	235	244	250
350	89	117	144	172	194	201	208	213	218	222	226	229	239	246
400	98	125	153	179	188	196	202	208	213	217	221	224	235	242
450	107	134	162	174	183	191	197	203	208	212	216	220	230	238
500	116	143	160	170	179	186	193	198	203	208	212	215	226	235

LENGTH OF 10" DIAMETER MAIN LINE IN FEET

LENGTH OF 6" LATERAL	25	50	75	100	125	150	175	200	225	250	275	300	400	500
25	37	65	92	120	147	175	202	230	257	277	278	278	279	280
50	47	75	102	130	157	185	212	240	267	271	272	273	276	277
75	57	85	112	140	167	195	222	250	265	266	267	269	272	274
100	67	95	122	150	177	205	232	257	260	262	263	265	269	271
125	77	105	132	160	187	215	242	253	255	257	259	261	266	269
150	87	114	142	169	197	224	245	248	251	254	256	257	263	266
175	97	124	152	179	207	234	241	245	248	250	252	254	260	264
200	107	134	162	189	217	233	237	241	244	247	249	251	258	262
225	117	144	172	199	225	230	234	238	241	244	246	248	255	260
250	127	154	182	209	222	227	231	235	238	241	243	246	253	258
275	136	164	191	213	219	224	229	232	236	238	241	243	251	256
300	146	174	201	211	217	222	226	230	233	236	239	241	249	254
350	166	192	200	207	212	217	222	226	229	232	235	237	245	250
400	181	190	197	203	209	214	218	222	225	228	231	233	241	247
450	180	188	195	201	206	211	215	218	222	225	227	230	238	244
500	179	186	193	198	203	208	212	215	219	222	224	227	235	241

MINIMUM HOLDING TIME IN SECONDS
REQUIRED FOR PRESSURE TO DROP
FROM 3½ TO 2½ PSIG

LENGTH OF 12" DIAMETER MAIN LINE IN FEET

LENGTH OF 4" LATERAL	25	50	75	100	125	150	175	200	225	250	275	300	400	500
25	44	84	123	163	202	242	282	321	332	333	334	334	336	336
50	48	88	128	167	207	246	296	323	324	326	327	328	331	333
75	53	92	132	172	211	251	290	316	317	319	321	323	327	339
100	57	97	136	176	216	255	295	308	311	313	316	317	323	326
125	62	101	141	180	220	260	297	301	304	308	310	312	319	323
150	66	106	145	185	224	264	290	295	299	302	305	308	315	319
175	70	110	150	189	229	268	283	289	293	297	300	303	311	316
200	75	114	154	194	233	271	277	283	288	292	296	299	308	313
225	79	119	158	198	238	265	272	278	283	288	291	295	304	310
250	84	123	163	202	242	259	267	273	278	283	287	291	301	308
275	88	128	167	207	244	254	262	269	274	279	283	287	298	305
300	92	132	172	211	239	249	257	264	270	275	279	283	295	302
350	101	141	180	218	231	241	249	256	262	268	272	276	289	297
400	110	150	189	210	223	233	242	249	255	261	266	270	283	292
450	119	158	189	204	216	227	235	243	249	255	260	264	278	288
500	128	166	184	198	210	221	229	237	243	249	254	259	273	283

LENGTH OF 12" DIAMETER MAIN LINE IN FEET

LENGTH OF 6" LATERAL	25	50	75	100	125	150	175	200	225	250	275	300	400	500
25	50	89	129	168	208	248	287	327	331	332	333	333	335	336
50	59	99	139	178	218	257	297	321	323	325	326	327	330	332
75	69	109	149	188	228	267	307	314	316	318	320	321	326	328
100	79	119	158	198	238	277	302	306	309	312	314	316	321	325
125	89	129	168	208	248	287	295	300	303	306	309	311	317	321
150	99	139	178	218	257	284	289	294	298	301	304	306	314	318
175	109	149	188	228	267	278	284	289	293	296	299	302	310	315
200	119	158	198	238	265	272	278	284	288	292	295	298	306	312
225	129	168	208	248	260	268	274	279	284	288	291	294	303	309
250	139	178	218	246	255	263	269	275	280	284	287	290	300	306
275	149	188	228	242	251	259	266	271	276	280	284	287	297	304
300	158	198	227	238	248	255	262	268	272	277	281	284	294	301
350	178	208	221	232	241	249	255	261	266	271	274	278	289	296
400	189	204	217	227	236	243	250	256	261	265	269	273	284	292
450	187	201	213	223	231	239	245	251	256	260	264	268	279	288
500	186	199	210	219	227	234	240	246	251	256	260	263	275	284

B. Air Test for PVC Gravity Sewers

1. Test Section: Each section of sewer between two successive manholes shall be tested by plugging all pipe outlets with suitable test plugs. All test plugs shall be secured in place to prevent movement or slippage.
2. Addition of Air: Air shall be slowly added until the internal pressure is raised to 4.0 pounds per square inch gage (psig). The compressor used to add air to the pipe shall have a blowoff valve set at 5 psig to ensure that at no time the internal pressure in the pipe exceeds 5 psig.
3. Internal Pressure: The internal pressure of 4 psig shall be maintained for at least two minutes to allow the air temperature to stabilize, after which the air supply shall be disconnected and the pressure allowed to decrease to 3.5 psig.
4. Minimum Duration for Allowable Pressure Drop: The time in minutes that is required for the internal air pressure to drop from 3.5 psig to 3.0 psig shall be measured. The results shall not be less than the minimum permissible duration for air test pressure drop shown below.

Minimum Duration for Air Test Pressure Drop	
Pipe Size (Inches)	Time (Minutes)
4	2 1/2
6	4
8	5
10	6 1/2
12	7 1/2
15	9 1/2

5. Retest: If the pressure drop from 3.5 psig to 3.0 psig occurs in less time than the above-tabulated or calculated values, the pipe shall be overhauled and, if necessary, replaced and relaid until the joints and pipe shall hold satisfactorily under this test.

C. Infiltration Test

1. Preparation of Test Section: The end of the sewer at the upper structure shall be closed to prevent the entrance of water, and pumping of groundwater shall be discontinued for at least three days, after which the section shall be tested for infiltration.
2. Allowable Infiltration Rate: The infiltration shall not exceed 0.025 gpm per inch of diameter per 1,000 feet of main line sewer being tested, not including the length of laterals entering that section.
3. Excessive Infiltration: Where infiltration in excess of the allowable amount is discovered before completion and acceptance of the sewer, the sewer shall be immediately uncovered and the amount of the infiltration reduced to a quality within the specified amount of infiltration, before the sewer is accepted.

4. Individual Leaks: Even if the infiltration is less than the allowable amount, any individual leaks that may be observed shall be stopped as ordered by the District Representative.
5. Completion of Tests: All tests must be completed before the street or trench is resurfaced, unless otherwise directed by the District Representative.

D. Deflection Test

General: All flexible and semi-rigid main line pipe shall be tested for deflection, joint displacement, or other obstruction by passing a rigid mandrel through the pipe by hand, not less than 30 days after completion of the trench backfill, but prior to permanent resurfacing. The mandrel shall be a full circle, solid cylinder, or a cylinder, approved by the District as to design and manufacture. The circular cross section of the mandrel shall have a diameter of at least 95 percent of the specified average inside pipe diameter of the pipe.

E. Manhole Test

1. General: Water tightness of manholes shall be tested in connection with tests of sanitary sewers, or at the time the manhole is completed and backfilled.
2. Plugs: All manhole inlets and outlets shall be plugged with approved stoppers or plugs.
3. Fill Level: The manhole shall be filled with water to 2-inches below the bottom of the tapered cone section, with a minimum depth of 4 feet and a maximum depth of 20 feet. The water shall stand in the manhole for a minimum of one hour to allow the manhole material to reach maximum absorption. Before the test is begun, the manhole shall be refilled to the original depth as needed.
4. Test Requirements: The drop in water surface shall be recorded after a period of from 15 minutes to one hour. The time of the test shall be determined by the District Representative and may be varied to fit the various field conditions. The maximum allowable drop in the water surface shall be ½-inch for each 15-minute period of testing.
5. Visible Leaks: Even though the leakage is less than the specified amount, the Contractor shall stop any leaks that may be observed, to the satisfaction of the District Representative.

END OF SECTION

SECTION 15051: INSTALLATION OF PRESSURE PIPELINES

PART 1 - GENERAL

A. Description

This section describes the installation of: pressure pipelines fabricated of polyvinyl chloride, ductile iron, and welded steel, including pipeline closures and connections and pipeline encasement.

B. Related Work Described Elsewhere

1. Trenching, Backfilling, and Compacting: 02223
2. Concrete: 03300
3. Painting and Coating: 09900
4. Chlorination of Water Mains, Wells and Reservoirs: 15041
5. Hydrostatic Testing of Pressure Pipelines: 15042
6. Combination Air-Release and Vacuum Relief Valves: 15089
7. Facilities Identification: 15151
8. Cathodic Protection and Joint Bonding: 16640

C. Submittals

1. Shop drawings shall be submitted in accordance with the General Provisions and as specified herein.
2. An installation schedule (tabulated layout) shall be submitted which includes:
 - a. Order of installation and closures.
 - b. Pipe centerline station and elevation at each change of grade and alignment.
 - c. Elements, curves, and bends, both in horizontal and vertical alignment including elements of the resultant true angular deflections in cases of combined curvature.
 - d. The location, length, size, design designation, and number designation of each pipe section and pipe special.
 - e. Locations of junction structures.
3. Welder qualification certificates shall be submitted.

PART 2 - MATERIALS

A. Installation Material

Refer to the various referenced sections on pipe by type for material requirements.

B. Piping Schedule

Unless noted otherwise on the plans or in the specifications, pipe shall be furnished in accordance with the following materials schedule.

Diameter	Domestic Water	Recycled Water	Sewer Force Main
2-inch and smaller	Copper	Copper	--
4-inch through 12-inch	PVC C900 DIP	Purple PVC C900 DIP	PVC C900 Fusion Welded HDPE
14-inch through 24-inch	PVC C900 DIP CML&C Steel	Purple PVC C900 DIP CML&C Steel	PVC C900 Fusion Welded HDPE
Above 24-inch and through 36-inch	PVC C-900 DIP CML&C Steel	DIP CML&C Steel	PVC C900 CCFRPM (Hobas) Pressure Pipe
42-inch and larger	DIP CML&C Steel	DIP CML&C Steel	Special design

Notes: DIP - Ductile iron pipe per Section 15056.
Copper - Per Section 15057.
PVC C900 - PVC pressure pipe per Section 15064.
CML&C - Cement mortar lined and coated steel pipe per Section 15076. Fully welded joints for diameters ≥ 24 ".

PART 3 - EXECUTION

A. Delivery and Temporary Storage of Pipe at Site

1. Onsite Storage Limitation: Onsite pipe storage shall be limited to a maximum of one week, unless exception is approved by District.
2. Care of Pipe: Care shall be taken to avoid cracking of the cement mortar coating and/or lining on steel pipe. If necessary, plastic sheet caps shall be used to close pipe ends and keep coatings and linings moist.

B. Handling of Pipe

1. Moving Pipe: Pipes shall be lifted with handling beams or wide belt slings as recommended by the pipe manufacturer. Cable slings shall not be used. Pipe shall be handled in a manner to avoid damage to the pipe. Pipe shall not be dropped or dumped from trucks or into trenches under any circumstances.
2. Internal Pipe Braces: Internal braces placed in steel pipes shall be maintained until backfilling and compaction are completed.

3. Pipe Caps: Plastic caps placed over the ends of steel pipe shall not be removed until the pipe is ready to be placed in the trench. Plastic caps may be opened temporarily to spray water inside the pipe for moisture control.
4. Inspection of Pipe: The pipe and accessories shall be inspected for defects prior to lowering into the trench. Any defective, damaged or unsound pipe shall be repaired or replaced. All foreign matter or dirt shall be removed from the interior of the pipe before lowering into position in the trench.

C. Placement of Pipe in Trench

1. General: Dewatering, excavation, shoring, sheeting, bracing, backfilling material placement, material compaction, compaction testing, and pipe laying requirements and limitations shall be in accordance with Section 02223, Trenching, Backfilling and Compacting.
2. Sanitation of Pipe Interior: During laying operations, tools, clothing, or other materials shall not be placed in the pipe.
3. Prevention of Entry into Pipe: When pipe laying is not in progress, including lunch-hour, the ends of the pipe shall be closed using plugs constructed in a manner to prevent entry by any debris, animal or vermin.
4. Laying Pipe on Grades over 5 Percent: Pipes shall be laid uphill with the bell or collared joints on the uphill end of each pipe length, whenever the grade exceeds five percent.
5. Pipe Base Thickness: Pipe base thickness shall be as specified in Section 02223, Trenching, Backfilling, and Compacting.
6. Depressions at Joints and Pipe Sling Points: Depressions shall be dug into pipe base material to accommodate the pipe bell and external joint filler form ("diapers"), and to permit removal of the pipe handling slings.
7. Placement of Pipe on Pipe Base: Pipe shall be lowered onto the bedding and installed to line and grade its full length on firm bearing except at the bell and at sling depressions. Unless specified otherwise, the tolerance on grade shall be 1/4-inch; the tolerance on line shall be 1-inch. Grade shall be measured along the pipe invert.
8. Pipe Installation: Pipe shall be installed without springing, forcing, or stressing the pipe or any adjacent connecting valves or equipment. Precautions shall be taken to prevent pipe from being displaced by water entering trench. Damaged or displaced pipe shall be replaced or returned to specified condition and grade.
9. Trench Curvature and Pipe Deflection: The radius of curvature of the trench shall be determined by the maximum length of pipe section that can be used without exceeding the allowable deflection at each pipe joint and without causing deviation from the District's trench width requirements. Refer to the various referenced sections on pipe by type for allowable deflection. The deflection at any flexible joint shall not exceed that prescribed by the manufacturer of the pipe. The manufacturer's printed installation guide outlining the radius of curvature that can be negotiated with pipe sections of various lengths shall be followed.

10. Equipment for Installation of Pipe: Proper implements, tools, and facilities as recommended by the pipe manufacturer's standard printed installation instructions shall be provided and used by the Contractor for safe and efficient execution of the work. All pipe, fittings, valves, and accessories shall be carefully lowered into the trench using suitable equipment in such a manner as to prevent damage to pipe and fittings. Under no circumstances shall pipe or accessories be dropped or dumped into the trench.
11. Cutting and Machining Pipe: Cutting and machining of the pipe shall be accomplished in accordance with the pipe manufacturer's standard procedures for this operation. Pipe shall not be cut with a cold chisel, standard iron pipe cutter, nor any other method that may fracture the pipe or produce ragged, uneven edges.

D. Assembling Rubber-Gasketed Joints

1. Cleaning Ends of Pipe: The ends of the pipe to be joined shall be cleaned of foreign material.
2. Lubrication: After placing pipe in trench, a nontoxic water soluble vegetable soap solution shall be applied to the inside of the bell of the pipe in the trench and to the rubber gasket and spigot of the pipe to be installed. The rubber gasket shall be stretched into the groove in the bell-end of the pipe and distributed uniformly around the circumference.
3. Joint Assembly: Without tilting the pipe to be installed, the spigot shall be inserted into the bell of the pipe. Come-a-longs or pipe jacks shall be used to drive spigot end into the bell until properly seated. The joint recess recommended by pipe manufacturer for made-up joints shall be maintained. Where deflections at joints are required for curved alignment, the manufacturer's recommended allowable joint opening on one side shall not be exceeded. A feeler gauge shall be used to verify proper placement of each gasket.

E. Flanged Connections

1. Bolt hole Alignment: Pipe shall be set with flange bolt holes straddling the pipe horizontal and vertical centerlines.
2. Nuts and Bolts: Nuts and bolts shall be lubricated with anti-seize prior to installation.
3. Flange Wrapping: Flanges which connect with buried valves or other equipment shall be wrapped with sheet polyethylene film as specified for the valves and equipment in Section 15056, Ductile-Iron Pipe and Fittings. The wrap shall be extended over the flanges and bolts and secured around the adjacent pipe circumference with tape. For insulating joints, wrapping shall comply with Section 16640, Cathodic Protection and Joint Bonding.

F. Installation of Bends, Tees, and Reducers

Fittings shall be installed utilizing standard installation procedures. Fittings shall be lowered into trench by means of rope, cable, chain, or other acceptable means without damage to the fittings. Cable, rope, or other devices used for lowering fitting into trench, shall be attached around exterior of fitting for handling. Under no circumstances shall

the cable, rope or other device be attached through the fittings interior for handling. Fittings shall be carefully connected to pipe or other facility, and joint shall be checked to insure a sound and proper joint.

G. Installing Threaded Piping

Threaded piping shall be reamed, deburred, and cleaned before making up joints. Thread lubricant approved by the District's representative shall be applied to threaded pipe ends before installing fittings, couplings, unions, or joints.

H. Completion of Interior Joints for Mortar-Lined Pipes 20-Inches in Diameter and Smaller

1. Preparation: A tight-fitting swab or squeegee shall be inserted in the joint end of the pipe to be joined.
2. Application of Cement Mortar: When ready to insert the spigot, the face of the cement mortar lining at the bell shall be coated with a sufficient amount of stiff cement mortar to fill the space between adjacent mortar linings of the two pipes to be joined.
3. Removal of Excess Mortar: Immediately after joining the pipes, the swab or squeegee shall be drawn through the pipe to remove all excess mortar and expel it from the open pipe end.

I. Completion of Interior Joints for Mortar-Lined Pipes 24-Inches in Diameter and Larger

1. Backfill Requirement: The trench shall be backfilled, compacted, and meet compaction requirements before applying mortar at joints.
2. Cleaning and Application of Cement Mortar: Working inside the pipe, foreign substances which adhere to the steel joint rings shall be removed, the surface cleaned, and stiff cement mortar packed into each joint. The mortar shall be finished with a steel trowel to match the lining in the adjoining pipes.
3. Removal of Excess Mortar: Excess mortar and other construction debris shall be removed from the pipe interior.

J. Pipeline Closure Assemblies

1. General: Pipeline closure assemblies shall be employed to unite sections of pipeline laid from opposite directions; to adjust the field length of the pipeline to meet structures, other pipelines, and points established by design stations; and to close areas left open to accommodate temporary test bulkheads for hydrostatic testing. Either follower ring design or butt strap design shall be used. Follower ring closures shall be installed as recommended by the pipe manufacturer.
2. Butt Straps: As shown in the IRWD Standard Drawings, shaped steel butt straps a minimum of 10-inches in width shall be centered over the ends of the pipe sections they are to join. On pipes 39 inches in diameter and smaller, butt straps shall be welded to the outside of the pipes with complete circumferential fillet welds equal in size to the thinnest part being joined. The details shown on the drawings shall be referred to when joining larger pipes.

3. General Requirements for Cement Mortar Lining for Closure Assemblies: Closure assemblies shall be cement-mortar lined to a mortar thickness at least equal to the adjoining standard pipe sections. The steel shall be cleaned with wire brushes and a cement and water wash coat applied prior to applying the cement mortar. Where more than a 4-inch joint strip of mortar is required, welded wire mesh reinforcement having a 2-inch by 2-inch pattern of No. 12 gauge shall be placed over the exposed steel. The wires on the 4-inch spacing shall be crimped to support the mesh 3/8-inch from the metal surface. The interior mortar shall have a steel-trowled finish to match adjoining mortar lined pipe sections.
4. Lining Closure Assemblies: Butt straps with 5-inch diameter hand holes shall be provided for lining of closure assemblies on pipelines, as shown on the IRWD Standard Drawings.
5. Mortar Coating Exterior Surfaces of Closure Assemblies: The exterior of closure assemblies shall be reinforced with wire mesh as described in Paragraph 3 above. The surface shall be coated with mortar, or a poured concrete encasement to cover all steel to a minimum thickness of 1 1/2 inches. Exterior mortar shall be protected to retard drying while curing. Concrete shall be poured and vibrated on one side of the closure assembly only, until mortar is visible on the opposite side, after which the coating can be completed over the top of the assembly.

K. Welded Joints

1. Locations: Welded joints shall be provided where detailed on the plans and in every location where the operating pressure shall be greater than 150 psi.
2. Reference Standard: Welding shall be in accordance with AWWA C206. Welder's qualification shall be in accordance with Section IX of the ASME Boiler and Pressure Vessel Code. Current certifications shall be provided for all welders.
3. Sequence: Interior joints shall not be welded before backfilling, compaction, and compaction testing are successfully completed.
4. Joint Rings: Joint rings (butt-straps or weld collars) that are rusted or pitted where weld metal is to be deposited shall be cleaned by brushing or sand blasting.
5. Restrictions: Concrete or other coating adjacent to the joint rings shall not be heated.
6. Cleaning Requirements: Each layer of deposited weld metal shall be cleaned using a power-driven wire brush or grinder prior to depositing the next layer of weld metal.

L. Operations Incidental to Joint Completion

1. Hydrostatic Testing: Joint completion shall be planned to accommodate temporary test bulkheads for hydrostatic testing.
2. Bonding Pipe: Metallic jumper bonds or bars shall be installed on all metallic pipe, as shown on plans and as specified within Section 16640, Cathodic Protection and Joint Bonding.

M. Completion of Exterior Pipe Joint for Cement-Mortar Coated Pipe

Outside joint recess shall be filled with cement-mortar grout using a fabric form (joint diaper) placed around the joint and secured with steel straps. Grout shall be poured and rodded from one side only until it is visible on the opposite side. After approximately one hour, the joint shall be topped off with additional grout.

N. Thrust Restraint and Anchor Blocks

1. Location: Thrust restraint and anchor blocks shall be provided on all pressure pipelines, and shall be installed at all fittings that are not otherwise restrained. Thrust restraint blocks or anchor blocks shall be installed at all valves, tees, crosses, ends of pipelines, and at all changes of direction of the pipeline greater than 10 degrees deflection either vertically or horizontally when joints are not otherwise restrained.
2. General Requirements: Thrust restraint and anchor blocks shall be of not less than 3,000 psi concrete (Class C) and shall provide a thrust bearing area to resist horizontal or downward thrust. Thrust restraint and anchor blocks shall also be of sufficient gross weight and area to give bearing against undisturbed vertical earth banks sufficient to absorb the thrust, allowing an earth bearing of 1,500 pounds per square foot maximum. Thrust protection shall be set prior to pressurizing the line.
3. Thrust Restraint not Called for on the Plans: Thrust restraint elements, where not called for on the plans, shall be sized for 150 percent of operating pipeline pressure or the pipeline test pressure, whichever is greater. Prior to construction, thrust and anchor block sizing shall be submitted to the District for approval.
4. Concrete Placement: Concrete shall be placed against wetted and undisturbed soil, and the exterior of the fitting shall be cleaned and wetted to provide a good bond with the concrete. The concrete interface with the fitting shall be an area of not less than the projected area of the fitting normal to the thrust resultant and centered on the resultant.
5. Accessibility to Joints and Fittings: Unless otherwise directed by the District, thrust restraint and anchor blocks shall be placed so that the pipe and fitting joints are accessible for repair. Placement shall include isolation of adjacent utilities and shall ensure that bearing is against undisturbed soil.
6. Harness and Tie-Rods: Metal harness or tie-rods and pipe clamps shall be used to prevent movement if shown on the plans or directed by the District. The rods and clamp harnessing arrangement shall be installed utilizing flanged harness hold-downs or lugged fittings and pipe with saddle clamps placed (where feasible and practical) to bear against the pipe bells. Saddle clamps around the barrel of the pipe, which depend on friction to prevent sliding of the clamp, are acceptable. However, restraints with pointed set-screws which bear into the pipe wall, are not acceptable and shall not be used. All surfaces of exposed and buried steel rods, reinforcing steel, bolts, clamps, and other metal work shall be coated prior to backfilling, and touched up after assembly as specified in Section 09900, Painting and Coating, System D-1, "Buried Metal Coating Systems".

7. In-line Valves: Reinforcing steel tiedown rods shall be used on all in-line valves. Refer to the IRWD Standard Drawings for typical valve anchor and thrust restraint details. Exposed metal portions shall be coated with bitumastic material as specified in Section 09900, Painting and Coating, System D-1, "Buried Metal Coating Systems".

O. Blowoff Assemblies

1. General: In-line type or end-of-line type blowoff assemblies shall be installed in accordance with the plans at locations noted, and at such additional locations as required by the District for removing water or sediment from the pipeline.
2. Location: The assembly shall be installed in a level section of pipe. The tap for blowoff in the line shall be no closer than 18 inches to a valve, coupling, joint, or fitting unless it is at the end of the main. No tap will be permitted in any machined section of asbestos cement pipe.
3. Restrictions: Blowoffs shall not be connected to any sewer, submerged in any stream, or installed in any manner that will potentially allow back siphoning into the distribution system.

P. Combination Air and Vacuum Release Valves

1. General: Air release valve assemblies and combination air and vacuum valves shall be installed at each point in the pipeline as shown on the drawings or as specified by the District, and in accordance with Section 15089, Combination Air-Release and Vacuum Relief Valves.
2. Location: The tap for the air valves shall be made in a level section of pipe no closer than 18 inches to a bell, coupling, joint, or fitting. No tap shall be permitted in any machined section of asbestos cement pipe.

Q. Above-ground Piping Installation/Support

1. General: Installation of aboveground pipeline materials and appurtenances include requirements for buried pipeline materials and appurtenances as applicable.
2. Supports: All exposed pipe shall be adequately supported with devices of appropriate design. Where details are shown, the supports shall conform thereto and shall be placed as indicated; provided, that the support for all piping shall be complete and adequate as herein specified, whether or not supporting devices are specifically called for.
3. Grooved-End Pipe and Fittings: Grooved-end pipe and fittings shall be installed in accordance with the coupling manufacturer's recommendations and the following:
 - a. Loose scale, rust, oil, grease, and dirt shall be cleaned from the pipe or fitting groove. Lubricate the coupling gasket in accordance with the manufacturer's recommendations.
 - b. Coupling shall be tightened alternately and evenly until coupling halves are seated properly.

R. Cathodic Protection and Joint Bonding

All ferrous metal pipes and all pipes specified or shown on the plans to be cathodically protected shall be completed in accordance with Section 16640, Cathodic Protection and Joint Bonding.

S. ID and Locator Tape

The pipe identification shall be in accordance with Section 15151, Facilities Identification.

T. Disinfection

All potable water pipelines shall be disinfected in accordance with Section 15041, Chlorination of Water Mains, Wells and Reservoirs.

U. Testing

All piping shall be hydrostatically pressure tested in accordance with Section 15042, Hydrostatic Testing of Pressure Pipelines.

END OF SECTION

SECTION 15053: CARBON STEEL PIPE AND FITTINGS

PART 1 - GENERAL

A. Description

This section describes materials and installation of steel pipe and fittings. This pipe may serve general purposes such as for compressed air, and miscellaneous piping applications where Section 15076, Cement-Mortar Lined and Coated Steel Pipe does not apply. This section applies to piping applications that have a 300 psi or less operating pressure.

B. Related Work Specified Elsewhere

1. Painting and Coating: 09900
2. Installation of Pressure Pipelines: 15051
3. Cement-Mortar Lined and Coated Steel Pipe: 15076

C. Submittals

1. Shop drawings shall be submitted in accordance with the General Provisions and as specified herein.
2. Submit materials list showing material of pipe and fittings with ASTM reference and grade.

D. Measurement and Payment

1. Payment for the work in this section shall be in accordance with the General Provisions and the following.
2. Payment shall be by the linear foot for each diameter and for each pipe strength designation measured horizontally over the pipe centerline, exclusive of the distance between the inside faces of junction or other structures.

E. Inspection

The District reserves the right to inspect materials, production, or testing of pipe at the manufacturer's plant.

PART 2 - MATERIALS

A. Pipe

Pipe shall be black carbon steel, conforming to ASTM A53, Type E or S, Grade A or ASTM A135, Grade A. Pipe 12-inches in diameter and smaller shall be Schedule 40 or 80, as shown on plans, per ANSI B36.10. Pipe larger than 12-inches in diameter shall be standard weight per ANSI B36.10. Design thickness of the pipe shall be schedule 40 at a minimum. Pipe shall conform to AWWA C200, AWWA M11, with a minimum wall thickness of 0.2500 inches and as specified herein.

B. Threaded Nipples

Threaded nipples shall be of the same material as the pipe. Threads shall conform to ANSI B2.1.

C. Fittings and Joints

1. 3-Inches in Diameter and Smaller: Fittings 3-inches in diameter and smaller shall be threaded forged steel fittings (ASTM 05) conforming to ANSI B16.11, Class 3000.
2. Buried Fittings: Fittings for buried pipe larger than 3-inches in diameter shall be flanged or butt-welded, conforming to ANSI B16.9. Material shall conform to ASTM A234, Grade WPB. Wall thickness shall be the same as the pipe.
3. Above Ground Fittings Larger than 3-Inches in Diameter: Fittings for above ground or exposed pipe larger than 3-inches in diameter shall be grooved end or flanged, conforming to ANSI B16.9. Material shall conform to ASTM A234, Grade WPB. Wall thickness (except for grooved ends) shall be the same as the pipe. Grooved-end joints shall comply with AWWA C606. Smooth radius forged steel fittings are required in-lieu of fabricated steel fittings.

D. Unions

Unions shall be Class 300, malleable iron (ASTM A47, Grade 35018) brass to iron seat, conforming to ANSI B16.39. Ends shall be threaded per ANSI B1.2.01.

E. Grooved-End Couplings

Grooved-end couplings shall be ductile iron, ASTM A536, Grade 65-45-12 or greater. Gaskets shall be EPDM and shall conform to ASTM D2000. Couplings shall be flexible type, square cut groove, per AWWA C606. Couplings for pipe 24-inches in diameter and smaller shall be flexible type, square cut groove, per AWWA C-606, and shall be Victaulic Style 77.

F. Thread Lubricant

Teflon thread lubricating compound or Teflon tape shall be used for threaded joints.

G. Pipe Lining and Coating

1. Cement Mortar Lining and Coating: Where indicated on the plans, buried and exposed pipe shall be cement-mortar lined and coated in the shop per AWWA C205, and as specified in Section 15076, Cement Mortar Lined and Coated Steel Pipe.
2. Buried Piping: Where indicated on the plans, buried pipe shall be factory lined and coated per Section 09900, Painting and Coating.
3. Exposed Piping: Piping located above ground or in vaults and structures shall be coated per Section 09900, Painting and Coating.

H. Flanges

1. General: Weld-neck flanges (conforming to ANSI B16.5) shall be provided for piping 3-inches in diameter and smaller to connect to flanged valves, fittings, or equipment. Slip-on or weld-neck flanges shall be provided for piping 4-inches in diameter and larger, in accordance with AWWA C207. Flanges shall match the connecting flanges on the adjacent fitting, valve, or piece of equipment. Flange material shall conform to ASTM A105, A 181, or A 182. Flanges shall be flat face.
2. Pressure Class: For test pressures 200 psi and less, Class 150 flanges, ANSI B16.5 shall be used. For test pressures greater than 200 psi, Class 300 flanges, ANSI B16.5 shall be used.

I. Bolts and Nuts

1. Bolts and nuts for flanged valves and flanges shall be Type 316 stainless steel conforming to ASTM A193, Grade B8M, for bolts and ASTM A194, Grade 8M, for nuts. For grooved-end fittings, bolts shall be Type 316 stainless steel and conform to ASTM F593 or ASTM A183 and have a minimum tensile strength of 100,000 psi.
2. Washers shall be provided for each nut, shall be of the same material as the nut, and shall be installed adjacent to the nut, between the nut and the flange.
3. The length of each bolt or stud shall be such that between 1/4-inch and 1/2-inch will project through the nut when drawn tight.

J. Gaskets for Flanges

1. Gaskets for Flanged Joints: Gaskets for flanged joints shall be 1/8-inch thick and be made of Ethylene Propylene Diene Monomer (EPDM), or synthetic fiber. Gaskets shall be suitable for a water pressure of 350 psi at a minimum temperature of 180°F. Gaskets shall be NSF 61 certified for potable water applications. For potable and non-potable water applications, gaskets shall be compatible with water that may have a chlorine residual of 25 mg/L.
2. Full Face Type Gaskets or Ring Gaskets for Flanged Joints: Full face type gaskets with pre-punched holes shall be used where both flanges are flat face. Ring gaskets extending to the inner edge of the bolts may be used where a raised face flange is present.
3. Manufacturers: Gaskets shall be Garlock 3760, 8314, and 98206; Klingersil 4401, Teadit Style 1082 SAN, or U.S. Pipe Flange-Tyte. NSF 61 certified gaskets shall be Garlock 3760-U and 98206, Teadit Style 1082 SAN, and U.S. Pipe Flange-Tyte.

K. Outlets

1. Outlets 2-Inches in Diameter and Smaller: Outlets, which are 2-inches in diameter and smaller, shall be made by welding on an extra-heavy steel weld-o-let threaded coupling. Refer to IRWD Standard Drawing details for water service connections to steel pipe.

2. Outlets Larger than 2-Inches in Diameter: For outlets larger than 2-inches in diameter, flanged tees with flanged nozzle outlets shall be used. Tee fittings shall be fabricated in accordance with the applicable portions of the latest revision of the AWWA Manual M11, "Steel Pipe – A Guide for Design and Installation".

Smooth radius forged steel fittings are required in-lieu of fabricated steel fittings.

By special permission from the District when the duration of shutdown is critical, outlets for connection to existing steel water pipelines may be made using fabricated steel nozzles. In such cases nozzle outlets shall be fabricated in accordance with the applicable portions of the latest revision of the AWWA Manual M11, "Steel Pipe – A Guide for Design and Installation". In all cases, a full-wrap reinforcing plate shall be welded around the outside of the pipe section; and (on the nozzle-size) a circular annular reinforcing collar plate (with minimum 1/4-inch thickness) shall be welded over the top of the steel wrapper pad, around the base of the nozzle opening. Refer to IRWD Standard Drawings for welding and plate details.

PART 3 - EXECUTION

A. Fabrication

1. Fabrication: Fabrication shall comply with ANSI B31.3, Chapter V.
2. Butt-Welded Joints: Beveled ends for butt-welding shall conform to ANSI B16.25. Slag shall be removed by chipping or grinding. Surfaces shall be clean of paint oil, rust, scale, slag, and other material detrimental to welding.
3. Weld Passes: The minimum number of passes for welded joints shall be as follows:

Steel Cylinder Thickness (inches)	Minimum Number of Passes for Welds
0.2500	2
0.2501 through 0.3750	3
0.3751 through 0.5000	4
0.5001 and greater	requires design review and District approval

All welds shall be continuous and fully circumferential.

4. Welding Process: The shielded metal arc welding (SMAW) process shall be used for welding.
5. Welding Preparation: Welding preparation shall comply with ANSI B31.3, paragraph 328.4. Limitations on imperfections in welds shall conform to the requirements in ANSI B31.3, Tables 341.3.2 and 341.3.2B, and paragraph 341.4 for visual examination.
6. Weld Identification: Welds shall be identified in accordance with ANSI B31.3, paragraph 328.5.

7. Cleaning Welds: Each layer of deposited weld metal, including the final pass, shall be cleaned with a power-driven wire brush prior to depositing the next layer of weld metal.
8. Welding Electrodes: Welding electrodes shall comply with AWS A5.1 or A5.5.

END OF SECTION

SECTION 15056: DUCTILE-IRON PIPE AND FITTINGS

PART 1 - GENERAL

A. Description

This section describes materials, installation, and testing of ductile-iron pipe and fittings.

B. Related Work Specified Elsewhere

1. Trenching, Backfilling, and Compacting: 02223
2. Painting and Coating: 09900
3. Chlorination of Water Mains, Wells and Reservoirs: 15041
4. Hydrostatic Testing of Pressure Pipelines: 15042
5. Installation of Pressure Pipelines: 15051
6. Manual Valves: 15100
7. Flexible Pipe Couplings and Expansion Joints: 15162
8. Cathodic Protection and Joint Bonding: 16640

C. Submittals

1. Shop drawings shall be submitted in accordance with the General Provisions and as specified herein.
2. Affidavits of compliance with standards referenced in this specification, e.g., AWWA C151, shall be provided.
3. Layout drawings showing the locations and dimensions of pipe and fittings shall be submitted where the proposed pipeline is to be placed along streets or alignments with a radius of curvature which dictates the use of shorter-than-standard pipe lengths. In cases where restrained joint pipe is specified, lay drawings shall clearly identify the joints, lengths, fittings, and deviations from the curved centerline of the pipe trench. Consideration for adjacent parallel utility conduits is important in developing the lay drawings to avoid conflicts and encroaching into adjacent trench areas.
4. Lining, coating and wall thickness for all piping shall be provided.
5. Joint details for all types of joints used shall be submitted.
6. Calculations and/or test data proving that each proposed restrained joint arrangement can transmit the required forces shall be submitted.

D. Measurement and Payment

1. Payment for the work in this section shall be in accordance with the General Provisions and the following.
2. Payment shall be by the linear foot for each diameter and for each pipe strength designation measured horizontally over the pipe centerline, exclusive of the distance between the inside faces of junctions or other structures.

E. Inspection

The District reserves the right to inspect materials, production, and testing of pipes, fittings, and special pieces at the manufacturer's plant.

F. Delivery, Storage, and Handling

1. Care shall be exercised in handling, loading, unloading, and storing ductile-iron pipe and fittings to avoid distortion, scratches, gouges, dents, and, in particular, scuffing of the ends.
2. All ductile-iron pipe and fittings shall be stored under cover in a flat, horizontal position, and protected from the sun and the elements until ready for installation.
3. Ductile-iron pipe shall be transported in a vehicle having a bed long enough to provide support for the full length of the pipe.
4. Any length of pipe or fitting that has been damaged or distorted shall be replaced.
5. When work is not in progress, open ends of pipe and fittings shall be securely closed so that no water, earth, or other substances will enter the pipe or fittings.

PART 2 - MATERIALS

A. Ductile-Iron Pipe

1. AWWA Reference Standard: Ductile-iron pipe shall be manufactured in accordance with ANSI/AWWA C151/A-21.51.
2. Minimum Wall Thickness: The minimum wall thickness for ductile-iron pipe shall be as specified in AWWA C150 for the design pressure class, and thickness Class 53 for flanged spools, unless indicated otherwise on the plans or elsewhere in the project specifications.
3. Joints: Unless otherwise called out on the plans or elsewhere in the project specifications, push-on type joints shall be used. The joint dimension and gasket shall be as specified in ANSI/AWWA C111/ A-21.11. All pipe joints shall be bonded to provide electrical continuity for corrosion monitoring and future cathodic protection. For joint-bonding details and requirements refer to the IRWD Standard Drawings and to Section 16640, Cathodic Protection and Joint Bonding.
4. Flanges: Flanges for ductile-iron pipe, when required, shall be "screwed-on" type in accordance with ANSI/AWWA C115/A-21.15.

5. Manufacturers: Ductile-iron pipe shall be as manufactured by American Cast Iron Pipe Company, Electrosteel Ductile Iron Pipe, Griffin Pipe Products Company, McWane Cast Iron Pipe Company/McWane Ductile, or U.S. Pipe and Foundry Company.
6. Restrained Joints: Where called for on the plans, pipe and fittings shall be restrained. Restrained joints shall be as specified in this Section and shall be one of the following types:
 - a. Flanged fittings.
 - b. Manufactured locking restraint pipe with fittings.
 - i. Acceptable products and manufacturers include: TR-Flex by U.S. Pipe & Foundry Company or Clow Water Systems, Flex Ring by American Cast Iron Pipe, or Thrust-Lock by Pacific States Cast Iron Pipe Company.
 - ii. Field welding of ductile iron restrained joint or ductile iron components is not acceptable.
 - c. Mechanical Joints with Mechanical Joint Restraints.
 - d. Push-on joint pipe with restrained harness assembly. Restraint of push-on joints shall only be used where specifically called for on the plans. Shop drawings reflecting every part, material and dimension of the restraint assembly shall be submitted to the District for approval.
 - i. Restraint systems using lugs integral to the pipe shall be cast with the pipe or fitting by the pipe manufacturer. Attachment of angle iron; angle-clips; harness-lugs or tabs by field welding to the ductile iron pipe or fitting is strictly prohibited.
 - (a.) All threaded harness parts shall be manufactured of type 316 stainless steel.
 - ii. Restraint of push-on joints shall be of the type utilizing cast lugs, or retainer rings bearing against the pipe shoulders at the bell or fitting.
 - e. Grooved pipe and fittings (for above grade or in vaults).

B. Ductile-Iron Fittings

1. AWWA Reference Standard: Ductile-iron fittings shall be manufactured in accordance with ANSI/AWWA C110/A-21.10 or ANSI/AWWA C153/A-21.53.
2. Push-on Joints: All pipe fittings shall be made with push-on joints designed for use with the type of pipe to be joined unless noted otherwise on the plans.
3. Restrained Joints: Restrained joints shall be as called for on the plans. Joint restraint type shall be as specified in this Section for ductile iron pipe, and shall be as specified under Part 2.A above.

4. **Bell Ends:** Bell ends shall be compatible with the pipe ends so as to provide confinement of the rubber rings and prevent damage to the ends of the pipe. Ring grooves and interior surfaces of the bell shall be smooth and free from ridges, notches, or uneven surfaces.
5. **Mechanical Joints:** Mechanical joint fittings will be allowed only in areas specifically called for on the project plans or as approved by the District as a substitute for other types of fittings. Mechanical joint fittings will be used in areas where there is limited room for a thrust block or in cases where the pipeline needs to be activated in a short period of time. These ductile iron fittings shall comply with ANSI / AWWA C111/A-21.11, with a pressure rating of 250 psi and an ANSI Class 125 and Class 150 bolt pattern. Tee-bolts for mechanical joint fittings shall be Type 316 stainless steel.

Field applications where speed of construction to facilitate tie-ins and where there is limited space available for concrete thrust blocks, are examples of where mechanical joint fittings with retainer glands are appropriate.

6. **Mechanical Joint Restraint Systems:** Mechanical joints with retainer gland fittings will only be allowed in areas specifically called for on the project plans or as approved by the District as a substitute for other types of fittings. Mechanical joint fittings shall meet or exceed the ASTM A536 requirements. Torque off bolts shall be tightened per manufacturer's recommendations and shall be inspected by the District prior to backfill. Approved manufacturers include: EBAA Iron, Ford Products, Romac Products, Sigma, SIP Industries, or Star Pipe Products.
7. **Flanged Fittings:** Unless otherwise indicated on the drawings, all fittings with flanged ends shall comply with ANSI/AWWA C110/A21.10, with a pressure rating of 250 psi and a Class 125 ASME/ANSI B-16.1 flange or an ANSI/AWWA C115/A-21.15 Class 125 flange. The gasket surface shall have a serrated finish of approximately 16 serrations per inch, approximately 1/32-inch deep, with serrations in either a concentric or spiral pattern. In addition, all flanges shall meet the following tolerances:

Description	Tolerance (inches)
Bolt circle drilling	+1/16
Bolt hole spacing	+1/32
Eccentricity of bolt-circle & facing with respect to bore center	+1/32

8. **Manufacturers:** Fittings shall be manufactured by American Pipe, McWane Ductile, Sigma, SIP Industries, Star Pipe Products, Tyler, or U.S. Pipe.

C. **Gaskets**

1. **Gaskets for Flanged Joints:** Gaskets for flanged joints shall be 1/8-inch thick and be made of Ethylene Propylene Diene Monomer (EPDM), or synthetic fiber. Gaskets shall be suitable for a water pressure of 350 psi at a minimum temperature of 180°F. Gaskets shall be NSF 61 certified for potable water applications. For potable and non-potable water applications, gaskets shall be compatible with water that may have a chlorine residual of 25 mg/L.

2. Full Face Type Gaskets or Ring Gaskets for Flanged Joints: Full face type gaskets with pre-punched holes shall be used where both flanges are flat face. Ring gaskets extending to the inner edge of the bolts may be used where a raised face flange is present.
3. Gaskets for Push-on, Mechanical, and Restrained Joints: Gaskets for push-on, mechanical, and restrained joints shall be synthetic rubber in accordance with AWWA C111.
4. Manufacturers: Gaskets shall be Garlock 3760, 8314, and 98206; Klingersil 4401, Teadit Style 1082 SAN, or U.S. Pipe Flange-Tyte. NSF 61 certified gaskets shall be Garlock 3760-U and 98206, Teadit Style 1082 SAN, and U.S. Pipe Flange-Tyte.

D. Bolts, Nuts, and Washers

1. Bolts and nuts for flanged valves and flanges shall be Type 316 stainless steel conforming to ASTM A193, Grade B8M, for bolts and ASTM A194, Grade 8M, for nuts. For grooved-end fittings, bolts shall be Type 316 stainless steel and conform to ASTM F593 or ASTM A183 and have a minimum tensile strength of 100,000 psi.
2. Washers shall be provided for each nut, shall be of the same material as the nut, and shall be installed adjacent to the nut, between the nut and the flange.
3. The length of each bolt or stud shall be such that between 1/4-inch and 1/2-inch will project through the nut when drawn tight.

E. Grooved-End Fittings and Couplings

Grooved-end fittings shall conform to AWWA C606, rigid radius-cut groove. Grooved-end couplings shall be ductile iron, ASTM A536, Grade 65-45-12. Gaskets shall be EPDM and shall conform to ASTM D2000. Coupling shall be Victaulic, Style 31, or Grinnell. All of the threaded parts shall be Type 316 stainless steel and shall be lubricated with anti-seize compound. Where the restrained joint is of the grooved type, the wall thickness beneath the groove shall be equal to or greater than the minimum specified wall thickness and shall be sufficient to meet the maximum pressure.

F. Lining for Pipe and Fittings

The interior of all pipe and fittings shall be lined with cement-mortar per ANSI/AWWA C104/A-21.4. Lining shall be the double thickness listed in AWWA C104, Section 4.8. Lining materials shall conform to ASTM C150, Type II.

G. Coating for Pipe and Fittings

Exterior surfaces of buried pipe and fittings shall be coated with an asphaltic material in conformance with ANSI/AWWA C110/A-21.10, and ANSI/AWWA C151/A-21.51. The coating shall be free from blisters and holes and shall adhere to the metal surface at ambient temperatures encountered in the field.

H. Polyethylene Encasement

Unless specified otherwise, pipe and fittings shall be polyethylene encased in accordance with ANSI/AWWA C105/A-21.5.

I. Flange Insulation Kits

Flange insulation kits, suitable for the design pressure of the pipeline, shall be provided where shown on the drawings, and shall be as specified in Section 16640, Cathodic Protection and Joint Bonding.

J. Joint Bonding

Provide joint bonding for each fitting and pipe joint with bonding wires as specified in Section 16640, Cathodic Protection and Joint Bonding.

PART 3 - EXECUTION

A. General

Ductile-iron pipe and ductile iron fittings shall be installed in accordance with the applicable sections of AWWA C600 and as specified in Section 15051, Installation of Pressure Pipelines.

B. Installation

1. Allowable Joint Deflection for Restrained Joint Pipe and Fittings: For restrained joints, deflection of the joint shall not exceed the manufacturer's recommended maximum deflection.
2. Acceptable Line and Grade for Piping: The pipe shall be laid true to the line and grade shown on the plans within acceptable tolerances. The tolerance on grade is 1-inch. The tolerance on line is 2-inches.
3. Touch-Up Coating: All exposed flanges and other metal surfaces and all damaged coatings shall be coated after assembly per Section 09900, Painting and Coating.

C. Wrapping pipe with Polyethylene Encasement

All ductile-iron pipe and fittings buried underground shall be protected with a polyethylene encasement wrap in accordance with AWWA C105. Wrap shall be a loose 8-mil thick LLD polyethylene tube or a 4-mil thick HDCL polyethylene tube. All joints between plastic tubes shall be wrapped with 2-inch wide, 10-mil thick, polyethylene adhesive tape, Polyken 900, or Scotchwrap 50. Installation of plastic film shall conform to the following.

1. Placement of Polyethylene Encasement: Using a sling, the pipe shall be picked up with a crane at the side of the trench and raised about 3 feet off the ground. The polyethylene tube, cut approximately 2 feet longer than the length of pipe, shall be slipped over the spigot end of the pipe and bunched up, accordion fashion, between end of the pipe and the sling.
2. Placement of Pipe into Trench: The pipe shall be lowered into the trench after the pipe is wrapped. The spigot shall be seated into the bell of the adjacent installed pipe, and the pipe lowered into the trench bottom. A shallow bell hole shall be provided in the trench bottom to facilitate the wrapping of the joint.

3. Joint Assembly: The pipe joint shall then be made up as described herein.
4. Adjustment of Polyethylene Encasement: The sling shall be removed from the center of the pipe and hooked into the bell cavity. The bell shall be raised approximately 12 inches and the tube of polyethylene film slipped along the full length of the pipe barrel. Enough of the film shall be left bunched up, accordion fashion, at each end of the pipe to overlap the adjoining pipe about 1 foot. Care shall be taken to ensure that soil that adheres to the pipe is removed as the polyethylene film is placed around the pipe.
5. Overlapped Joints: To make the overlapped joint wrap, the film shall be pulled over the bell of the pipe, folded around the adjacent spigot, and wrapped with about three circumferential turns of the plastic adhesive tape in order to seal the tube of film to the pipe. The tube on the adjacent pipe shall be then pulled over the first wrap on the pipe bell and sealed in place behind the bell, using about three circumferential turns of the polyethylene adhesive tape.
6. Attachment of Encasement: The resulting loose wrap on the barrel of the pipe shall be pulled snugly around the barrel of pipe, the excess material folded over the top and the fold held in place by means of short strips of the 2-inch wide, 10-mil thick adhesive tape at intervals 5 feet apart along the pipe barrel.

D. Flanged Connections

Flanged pipe and fittings shall be shop fabricated, not field fabricated. Threaded flanges shall comply with AWWA C115 and shall be individually fitted and machine tightened in the shop.

E. Mechanical Joint Connections with Retainer Gland Restraints:

Mechanical joint connections with retainer glands shall be assembled in accordance with the manufacturer's recommendations for the specific fitting and retainer gland. Torquing of break-off gland bolts shall be done in the presence of the District Representative. Each fitting shall be observed by the District Representative prior to bagging and backfill. Any such fittings not observed by the District Representative shall be excavated and exposed for detailed re-inspection of the fitting and bolt torque.

END OF SECTION

SECTION 15057: COPPER PIPE AND FITTINGS

PART 1 - GENERAL

A. Description

This section describes materials, installation, and testing of copper and brass pipe, and copper, and brass fittings and appurtenances.

B. Related Work Specified Elsewhere

1. Trenching, Backfilling, and Compacting: 02223
2. Painting and Coating: 09900
3. Hydrostatic Testing of Pressure Pipelines: 15042
4. Installation of Pressure Pipelines: 15051
5. Manual Valves: 15100
6. Cathodic Protection and Joint Bonding: Section 16640

C. Submittals

1. Shop drawings shall be submitted in accordance with the General Provisions and as specified herein.
2. Submit detailed layout if pipe runs in copper exceed 50 linear feet.
3. Submit catalogue order sheets for materials of pipe, flanges, flange insulation kits, companion flanges and unions, showing metal composition and conformance to industry standards (ASTM, etc.) specified. The material data sheets shall indicate NSF certification for materials used on the potable water system.

PART 2 - MATERIALS

A. Copper Pipe and Tubing

Copper piping shall conform to ASTM B88. Copper pipe and tubing shall be cylindrical, of uniform wall thickness, and shall be free from any cracks, seams, or other defects. Piping located above floors or suspended from ceilings shall be Type L. Piping buried or located beneath floor slabs shall be Type K. Copper pipe shall be as manufactured by Cambridge-Lee Industries, Inc., Cerro Copper Products Company, or Mueller Manufacturing Entities c/o Mueller Industries, Inc.

B. Copper Fittings

Copper fittings shall be copper conforming to ASTM B75 and ANSI B16.22, with solder end joints. Fittings 3/8-inch and smaller may have flared end connections or compression joint connections.

C. Solder

Solder shall be tin-silver solder conforming to ASTM B32, latest revision, Grade Sn94, Sn95 or Sn96. Cored solder shall not be used. Solder and flux used in joints of potable waterlines shall contain no more than 0.2 percent lead.

D. Brass Pipe and Nipples

Short threaded nipples and brass pipe shall conform to ASTM B43, regular wall thickness, except that nipples and pipe of sizes 1-inch and smaller shall be extra strong. Threads shall conform to ANSI B1.20.1.

E. Brass Appurtenances

1. General: All items specified herein shall be manufactured of brass conforming to AWWA C800 and shall meet NSF 61 requirements where the product is used on potable water.
2. Service Saddles: Service saddle bodies shall be manufactured of brass, stainless steel or nylon-coated malleable iron as called for in the IRWD Standard Drawings for the various types of pipe connections. Saddles shall be tapped with a female iron pipe thread outlet. The seal with the outer wall of the pipe shall be effected with either a rubber gasket or an O-ring, except for the stainless steel full-circle style repair clamp connection, which shall have a full-circle rubber gasket. Service saddles shall be as manufactured by A.Y. McDonald, Cambridge Brass, Ford Meter Box, Jones, Mueller, Romac, or Smith-Blair.
 - a. Asbestos-Cement or Ductile Iron Pipe: Service saddles shall be double strap type for all pipe sizes. The straps shall be flat and shall be manufactured of 316 stainless steel. Refer to IRWD Standard Drawings for details.
 - b. C900 PVC: Service saddles shall be manufactured of brass and shall be cast in two sections for pipe up to 8-inches in diameter. Service saddles for use on 10-inch and 12-inch diameter pipe shall have a brass top section and flat 316 stainless steel straps on the bottom of the saddle. Each saddle shall accurately fit the contour of the pipe O.D. without causing distortion of the pipe. The sections shall be securely held in place with type 316 stainless steel hex-head screws or bolts. The casting sections shall be tapped to receive the screws or bolts.
3. Corporation Stops: Corporation stops shall be manufactured of brass. The inlet fitting shall be a male iron pipe thread when used with saddle and the outlet connection shall be a compression type or iron-pipe thread. Corporation stops shall be "ball style" as manufactured by A.Y. McDonald, Cambridge Brass, Ford Meter Box, Jones, or Mueller.
4. Angle Meter Stops: Angle meter stops shall be of the "ball valve" style and shall be manufactured of brass. The inlet connection shall be an iron-pipe thread and the outlet fitting shall be a meter flange or meter coupling. The inlet and outlet shall form an angle of 90 degrees on a vertical plane through the centerline of the meter stop. A rectangular lug and lock wing shall be provided on the top of the fitting to operate the shutoff mechanism.

Two-inch angle meter stops shall be with "slotted" holes for 1 1/2-inch or 2-inch meters. Angle meter stops shall be of the "ball valve" style and shall be as manufactured by A.Y. McDonald, Cambridge Brass, Ford Meter Box, Jones, or Mueller.

5. Ball Valves for Flush-outs: Ball valves shall be in accordance with Section 15100, Manual Valves or Ford Meter Box BLA18-777-TA-NL. Ford Meter Box valves shall include a PVC threaded cap to protect the male threads on the outlet of the valve. Ball valves for flush-outs shall be installed in accordance with the IRWD Standard Drawings.
6. Customer Service Valve: Customer service valves shall be "ball valve" style manufactured of brass with lever-type turn handle. The inlet connection shall be a meter flange or a meter coupling and the outlet female iron pipe thread. Customer service valves shall be of the insulating style as manufactured by Mueller Corporation. Customer service valves shall be purchased from the District.

F. Connections & Cathodic Insulation

1. Underground pipe connections

For connections to underground piping, refer to the IRWD Standard Drawings pertaining to water service connections. Detail is provided to address the appropriate connection method for each different type of piping material being connected. Those details provide for insulation and address cathodic protection concerns. In general, the practice of using threaded PVC or nylon bushings shall not be allowed.

2. Above-ground & exposed pipe connections (in vaults):

Pipe, fittings, and appurtenances (air vacs, pressure gauges, etc.) made of dissimilar metals shall be isolated from each other. For applications where pipeline pressures exceed 150 psi, and where the pipe tap for the appurtenance into the main is larger than 1-inch in diameter, a 2 1/2-inch extra heavy carbon steel coupling shall be provided as the outlet, and the fitting/ appurtenance shall be isolated from the main by means of a 2 1/2 by 2-inch 316 stainless steel bushing, 2-inch 316 stainless steel nipple, and 2-inch stainless steel ball valve.

G. Flanges, Gaskets, Bolts and Nuts

1. Flanges for Valves and Fittings: Copper pipe shall be connected to flanged valves and fittings with bronze companion flanges conforming to ANSI B16.24, Class 125 (150 lb. Rating) to match the connecting flange. Solder end companion flanges shall be used for copper and threaded companion flanges shall be used for brass, or stainless steel pipe connections.
2. Gaskets: Gaskets for flanged-end fittings shall be made of synthetic rubber binder and shall be full-face, 1/8-inch thick John Crane Co. "Cranite", or Johns-Manville.
3. Flanged Connections: All flanged connections shall be made using, Type 316 stainless-steel bolts and nuts conforming to ASTM A193, Grade B8M, for bolts and ASTM A194, Grade 8M, for nuts. Washers shall be provided for each nut. Washers shall be of the same material as the nuts.

4. Flange Insulating Kits: Flange insulation kits, suitable for the design pressure of the pipeline, shall be provided where shown on the drawings and/or wherever pipelines of dissimilar metals are joined together. Insulation kits and materials shall be as specified in Section 16640, Cathodic Protection and Joint Bonding.

H. Unions

Unions for copper piping systems (non-buried applications) shall conform to the following. Unions shall be the same size as the pipe, and shall be of the three part type, with silver soldered "sweat" hub-end connections. Unions shall be brass conforming to AWWA C800. Unions shall be A. Y. McDonald, Ford Meter Box, Jones, Lee Brass, or Mueller.

PART 3 - EXECUTION

A. General

Pipe shall be installed without springing, forcing, or stressing the pipe or any adjacent connecting valves or equipment. Pipe hangers and supports, and pipe penetrations through walls, slabs, and floors shall be as detailed on the drawings.

B. Installing Flange Bolts and Nuts

1. Bolt Thread Lubrication: Bolt threads shall be lubricated with an anti-seize compound prior to installation. Anti-seize compound shall be as manufactured by Tri-Flow, Permatex, or Crouse-Hinds.
2. Flange Alignment: Flanged pipe shall be set with the flange bolt holes straddling the pipe horizontal and vertical centerlines. This is referred to as the "two holing" procedure.

C. Installation

1. Related Installation Specification: Pipe shall be installed in accordance with the requirements of Section 15051, Installation of Pressure Pipelines.
2. Pipe/Tubing Preparation: Tubing shall be cut square and burrs removed. Both the inside and outside of fitting and pipe ends shall be cleaned with steel wool and muriatic acid before soldering. Care shall be taken to prevent annealing by overheating of fittings and tubing when making connections. Miter joints shall not be permitted in lieu of elbows. Notching straight runs of pipe in lieu of tees shall not be permitted.
3. Pipe Bends: Bends in soft copper tubing shall be long sweep. Bends shall be shaped with shaping tools. Bends shall be formed without flattening, buckling, or thinning the tubing wall at any point.
4. Brazing: Brazing procedures shall be in accordance with Articles XII and XIII, Section IX, of the ASME Boiler and Pressure Vessel Code. Solder shall penetrate to the full depth of the bell in joints and fittings. Solders shall comply with ANSI B31.3, paragraph 328.

5. Pipe Flexibility and Minimum Cover for Service Laterals: Buried piping shall be installed with some slack to provide flexibility in the event of a load due to settlement, expansion or contraction. A minimum cover of 42-inches below the finished street grade shall be adhered to. The tubing is to be bedded and covered with sand or select material in accordance with Section 02223, Trenching, Backfilling, and Compaction.
6. Copper Service Laterals: All service laterals shall be either 1-inch diameter or 2-inch diameter copper tubing. Refer to the IRWD Standard Drawings. End connections for the corporation stop shall be compression type fittings. All other couplings, fittings, and joints shall be soldered.

Anodes for cathodic protection shall be used on all copper pipe installations in accordance with Section 16640, Cathodic Protection and Joint Bonding.

D. Service Saddles

1. Proximity to Valves, Couplings, Joints, and Fittings: Service saddles shall be no closer than 18-inches to valves, couplings, joints, or fittings unless it is at the end of the main. The installation of a service saddle on any machined section of asbestos cement pipe will not be permitted.
2. Pipe Surface Preparation: The surface of the pipe shall be cleaned, smoothed and de-burred to remove all loose material and to provide a hard, clean surface before installing the service saddle.
3. Installation: The service saddle shall be tightened firmly to ensure a tight seal; however, care shall be used to prevent damage or distortion of the pipe by over-tightening. Final torque setting shall be set with a torque wrench and shall be set at manufacturers recommendation with a District Representative present.
4. Pipe Tap: The tap into the pipe shall be made in accordance with the pipe manufacturer's recommendation. Tap hole diameter shall be 7/8-inch for 1-inch service taps and shall be 1 7/8-inch for 2-inch service taps.

END OF SECTION

SECTION 15064: PVC PRESSURE PIPE AND FITTINGS

PART 1 - GENERAL

A. Description

This section includes materials, installation, and testing of polyvinyl chloride (PVC) pipe for 4-inch through 36-inch diameter domestic water lines, recycled water lines, sewer force mains, and gravity sewer lines deeper than 20 feet, in accordance with the applicable provisions of AWWA C900.

B. Related Work Specified Elsewhere

1. Existing Facilities: 01045
2. Trenching, Backfilling, and Compacting: 02223
3. Installation of Gravity Sewer Pipelines: 02701
4. Chlorination of Water Mains, Wells and Reservoirs: 15041
5. Hydrostatic Testing of Pressure Pipelines: 15042
6. Installation of Pressure Pipelines: 15051
7. Ductile-Iron Pipe and Fittings: 15056
8. Copper Pipe and Fittings: 15057
9. Facilities Identification: 15151

C. Submittals

1. Shop drawings shall be submitted in accordance with the General Provisions and as specified herein.
2. Submit materials list showing material of pipe and fittings with ASTM reference and grade.

D. Measurement and Payment

1. Payment for work in this section shall be in accordance with the General Provisions and the following.
2. Payment shall be by the linear foot for each diameter and for each pipe strength designation measured horizontally along the pipe centerline.

E. Delivery, Storage, and Handling

1. Care shall be exercised in handling, loading, unloading, and storing PVC pipe and fittings to avoid distortion, scratches, gouges, dents, and, in particular, scuffing of the ends. Discolored pipe shall be rejected.

2. All plastic pipe and fittings shall be stored under cover in a flat, horizontal position, and protected from the sun and the elements until ready for installation. The covering shall be placed in such a way as to allow adequate air circulation between the cover and the pipe.
3. Plastic pipe shall be transported in a vehicle having a bed long enough to provide support for the full length of the pipe. The shipping company shall protect the loaded pipe to avoid vehicle exhaust during transit.
4. Any length of pipe or fitting that has been damaged or distorted shall be replaced.
5. When work is not in progress, open ends of pipe and fittings shall be securely closed so that no water, earth, or other substances will enter the pipe or fittings.

PART 2 - MATERIALS

A. PVC Pipe

1. General: PVC pipe shall be manufactured in accordance with AWWA C900, and shall be of the sizes and pressure classes shown on the plans. The dimension ratio (DR) for C900 PVC pressure pipe shall be DR-14 or thicker walled (lower DR). The pipe shall have gasketed bell end or plain end with elastomeric gasketed coupling.
2. Material: Material used to produce the pipe and couplings shall be made from Class 12454-A or B virgin compounds as defined in ASTM D1785, with an established hydrostatic design basis rating of 4,000 psi for water at 73.4°F (23°C).
3. Pipe Lengths: Laying lengths shall be 20 feet with the manufacturer's option to supply up to 15% random lengths (minimum length 10 feet).
4. Pipe Marking: Each pipe length shall be marked showing the date of manufacture, nominal pipe size and O.D. base, the AWWA DR, and the AWWA specification designation (AWWA C900). For potable water application, the seal of the testing agency that verified the suitability of the material for such service shall be included.
5. Manufacturers: Pipe shall be manufactured by Diamond Plastics Corporation, Ipex, Inc., JM Eagle, Vinyltech Corporation, or Westlake Pipe & Fittings.

B. Fittings

1. Materials: Fittings shall be ductile-iron conforming to Section 15056, Ductile-Iron Pipe and Fittings.
2. Bell Sizes: Bell size shall be for Class 235 (DR 18) and Class 305 (DR 14) iron-pipe-size equivalent PVC pipe, including the rubber-ring retaining groove.
3. Reference Standard: All castings shall be marked "DI" or "Ductile" and ANSI/AWWA C153/A21.53.

C. Rubber Rings

Rubber rings for use in couplings and fittings shall conform to the requirements of ASTM F477. Rubber rings shall be stored out of direct sun light, clearly labeled with the material type, and protected in a manner to prevent deterioration.

D. Service Saddles

Service saddles for 1-inch and 2-inch diameter outlets shall be designed for use on C900 PVC pipe and shall conform to the requirements of Section 15057, Copper Pipe and Fittings. The allowable upper pipeline diameter limit for use of service saddles shall be pipe nominally sized 12-inches in diameter. For outlets of larger than 2-inch diameter and for all outlets on larger diameter pipelines, ductile iron tees with flanged outlets shall be used. Refer to the IRWD Standard Drawings for additional service saddle requirements.

PART 3 - EXECUTION

A. General

1. Related Installation Specification: PVC pipe shall be installed in accordance with the requirements of Section 15051, Installation of Pressure Pipelines.
2. Restrictions: When pipe is to be installed in new streets or when street improvements require placement and/or replacement of curbs, piping shall not be installed until new curbs are in place, unless special approval by the District is obtained. If any curbing is damaged during piping installations, the damaged portions shall be repaired or replaced to the satisfaction of the agency having jurisdiction.
3. Closure Sections: Where closure sections are required, the sections shall be installed in accordance with the applicable portions of these specifications. Closures shall be made using gasketed-PVC closure collars.
4. Cover: The pipe sections shall be laid in the trench to true alignment and grade in accordance with the drawings. Where the grade is not shown, pipe shall have a cover of 42-inches in paved areas and 48-inches in unpaved areas. The pipe grade shall be approved by the District.
5. Curved Alignment: The pipe shall not be laid along curves at a radius less than that listed below. The minimum-radius curves are determined by the limit of 2-degree deflection for PVC pipe joints with factory-assembled bell couplings:

<u>Length of Pipe Section</u>	<u>Minimum Curve Radius</u>
20 feet	573 feet
10 feet	287 feet

For integral bell PVC pipe, the minimum radius curves obtained by deflecting joints shall not exceed the manufacturer's recommendation (which may be less than 2 degrees). Pipe may not be offset to a degree such that the spigot end of the pipe deflects (touches) against the end of the pipe bell. Pipe sections shall not be bent to achieve a curve.

B. Installation

1. Pipe Cutting: When pipe is cut and is to be joined to a ductile-iron fitting or another piece of pipe, the end shall be beveled in the field or shop to create a beveled end equal in workmanship to the machined ends of the pipe as furnished by the manufacturer. Such machining shall not result in undercutting the wall thickness and must be approved by the District Representative before installation.
2. Joints: Connecting parts of pipe, rings, couplings, and castings shall be cleaned before assembly. After bearing has been obtained, couplings shall be assembled in a workmanlike manner. The use of excessive lubricant will not be permitted, and the assembly of the couplings and rings shall be in accordance with the manufacturer's recommendations. Lubricant and rubber rings shall be supplied by the pipe manufacturer.

C. Pipe Identification

ID and locator tape shall be installed on all recycled water pipelines and potable water pipelines in accordance with Section 15151, Facilities Identification.

END OF SECTION

SECTION 15076: CEMENT-MORTAR LINED AND COATED STEEL PIPE

PART 1 - GENERAL

A. Description

This section describes materials, fabrication, installation, and testing of cement-mortar lined and coated steel pipe, in accordance with the latest applicable requirements of AWWA C200, C205, C206, C207, and C208.

B. Related Work Specified Elsewhere

1. Trenching, Backfilling, and Compacting: 02223
2. Painting and Coating: 09900
3. Interior Inspection for Cement-Mortar Lined Steel Pipe: 15040
4. Chlorination of Water Mains, Wells and Reservoirs: 15041
5. Hydrostatic Testing of Pressure Pipelines: 15042
6. Installation of Pressure Pipelines: 15051
7. Ductile-Iron Pipe and Fittings: 15056
8. Cathodic Protection and Joint Bonding: 16640

C. Submittals

Shop drawings shall be submitted in accordance with the General Provisions and the following:

1. Piping layout drawings showing location and dimensions of all pipe and fittings. Include lay lengths of valves, meters, and other equipment which determine piping dimensions. Label or number each fitting or piece of pipe and provide the following information for each item:
 - a. Materials of construction, including references to industry standards being met (i.e. ASTM, ANSI, AWWA, and other related standards).
 - b. Inside diameter, steel wall thickness, internal design pressure (cement-mortar lining and coating thicknesses) for each class of pipe to be furnished.
 - c. Order of installation and closure locations for length adjustment and for construction convenience.
 - d. Pipe invert station and elevation of each change of grade and alignment.
 - e. Elements of curves and bends, both in horizontal and vertical alignment, including elements of the resultant true angular deflections in cases of combined curvature.

- f. Paint primer type and thickness where joints and other cement-mortar holdbacks occur.
 - g. Call out types and sizes, and dimensions of grooved-end collars, flanges, reinforcing collars, wrapper plates, and crotch plates.
 - h. Limits of each reach of field-welded joints and of concrete encasement.
 - i. Locations of manholes and other points of access.
 - j. Location of valves and other mechanical equipment.
 - k. Locations of bulkheads for field hydrostatic testing of pipeline.
2. Manufacturer's certificates of compliance with prescribed industry standards (i.e. AWWA C200, C205, C206, C207 and C208, ASTM C150, and other related industry standards)
 3. Detail drawings of:
 - a. Fittings
 - b. Joints
 - c. Butt Straps
 - d. Bulkheads and means of attachment to pipe
 4. Mill test reports on each heat from which steel is rolled.
 5. Test reports on physical properties of elastomeric material used in gaskets.

D. Measurement and Payment

1. Payment for the work in this section shall be in accordance with the General Provisions and the following.
2. Payment shall be by the linear foot for each diameter and for each pipe strength designation measured horizontally over the pipe centerline, exclusive of the distance between inside faces of junction or other structures.

E. Inspection

The District reserves the right to inspect materials, production, or testing of pipe at the manufacturer's plant.

PART 2 - MATERIALS

A. Steel Pipe

1. Pipe shall conform to AWWA C200, AWWA M11, latest edition. Steel shall be ASTM A36, ASTM A1011 or A1018, Grade 36, having a 0.25% maximum carbon content.

2. Steel cylinder thickness shall be as shown on the plans, but in no case, shall the pipe thickness be less than the following.
 - a. For pipe less than 30-inches in diameter: Steel cylinder wall thickness shall be a minimum of 10 gauge (0.1345 inches) for straight runs of distribution and transmission pipe.
 - b. For pipe 30-inches in diameter and larger: Steel cylinder wall thickness shall be a minimum of 1/4-inch (0.2500 inches) for straight runs of distribution and transmission pipe.
 - c. For all pipe, regardless of the diameter: Steel cylinder wall thickness shall be 1/4-inch (0.2500 inches) within 10 feet on all sides of the following conditions.
 - i. Wherever the pipe is connecting to structures, vaults and other significant pipe appurtenances including, but not limited to, blow-offs, fittings, manways, PRV vaults, valve vaults, meter vaults, lift stations. Fittings shall include reducers, tees, and bends 45-degrees and greater. For grooved-end fittings, refer to the “Grooved-End Fittings” section herein for the pipe thickness requirements.
 - ii. Wherever the pipe is to be the installed or jacked inside pipe casings.
 - iii. Wherever pipe penetrations are required.

B. Cement

Cement for cement-mortar lining shall be ASTM C150, Type II or V. Cement for cement-mortar coating shall be ASTM C150, Type V.

C. Fittings

1. Definition: A fitting shall be defined as a piece of pipe other than a straight full length joint. Elbows, manhole sections, reducers, and sections of pipe with outlets shall be considered fittings. Dimensions shall be per AWWA C208.
2. Pressure Rating: Fittings 4 through 10-inches in diameter shall be designed for 250 psi and conform to ANSI B16.9. Fittings 12-inches in diameter and larger shall comply with AWWA C208.
3. Materials: Material for fittings 4 through 10-inches shall comply with ASTM A234, Grade WPB. Material for fittings larger than 10-inches but less than or equal to 30-inches in diameter shall be the same as the pipe. Cement-mortar lining and I.D. dimensions shall be the same as the specified pipe.

4. Design: Collars, wrapper plates, crotch plates, and other fittings shall be designed in accordance to AWWA M11.

- a. Long Radius Curves and Vertical Curves:

For curved alignment, straight or beveled pipe of normal or 1/2 normal lengths pulled partially open on one side of the joint may be used with a welded mitered bend of up to 10 degrees next to the joint ring. Pipes with a bend in excess of 10 degrees shall be designed as fittings.

Joints shall not be pulled more than one-half of the watertight extensibility provided by the bell and spigot design.

5. Grooved-End Fittings: Grooved end fittings 24-inches diameter and smaller shall have square cut grooves, flexible type, with dimensions as shown in AWWA C606, Table 3. Steel wall thickness shall be standard weight. Cement-mortar lining and I.D. dimensions shall be the same as for the specified pipe.
6. Welding Fittings: Welding fittings shall be standard weight, Tube Turns.

D. Flanges

Flanges shall be AWWA C207, Class D, flat face, except where Class E or Class F flanges are required.

E. Gaskets

1. Gaskets for Flanged Joints: Gaskets for flanged joints shall be 1/8-inch thick and be made of Ethylene Propylene Diene Monomer (EPDM), or synthetic fiber. Gaskets shall be suitable for a water pressure of 350 psi at a minimum temperature of 180°F. Gaskets shall be NSF 61 certified for potable water applications. For potable and non-potable water applications, gaskets shall be compatible with water that may have a chlorine residual of 25 mg/L.
2. Full Face Type Gaskets or Ring Gaskets for Flanged Joints: Full face type gaskets with pre-punched holes shall be used where both flanges are flat face. Ring gaskets extending to the inner edge of the bolts may be used where a raised face flange is present.
3. Gaskets for Push-on, Mechanical, and Restrained Joints: Gaskets for push-on, mechanical, and restrained joints shall be synthetic rubber in accordance with AWWA C111.
4. Manufacturers: Gaskets shall be Garlock 3760, 8314, and 98206; Klingersil 4401, Teadit Style 1082 SAN, or U.S. Pipe Flange-Tyte. NSF 61 certified gaskets shall be Garlock 3760-U and 98206, Teadit Style 1082 SAN, and U.S. Pipe Flange-Tyte.

F. Bolts, Nuts, and Washers

1. Bolts and nuts for flanged valves and flanges shall be Type 316 stainless steel conforming to ASTM A193, Grade B8M, for bolts and ASTM A194, Grade 8M, for nuts. For grooved-end fittings, bolts shall be Type 316 stainless steel and conform to ASTM F593 or ASTM A183 and have a minimum tensile strength of 100,000 psi.
2. Washers shall be provided for each nut, shall be of the same material as the nut, and shall be installed adjacent to the nut, between the nut and the flange.
3. The length of each bolt shall be such that between 1/4-inch and 1/2-inch will project through the nut when drawn tight. Studs may be used instead of bolts only where approved by the District Representative.
4. Bolts for Flange Insulation Kits: Bolts and nuts for flange insulation kits shall conform to the same requirements as outlined in paragraph 2.F.1 above.

G. Flange Insulation Kits

Flange insulation kits suitable for the design pressure of the pipeline shall be provided where shown on the drawings and shall be as specified in Section 16640, Cathodic Protection and Joint Bonding.

H. Grooved-End Couplings

Grooved-end couplings shall be ductile iron, ASTM A536, Grade 65-45-12 or greater. Bolts and nuts for couplings shall be Type 316 stainless steel and shall conform to ASTM A193 and A194. Gaskets shall be EPDM and shall conform to ASTM D2000. Couplings for pipe 24-inches in diameter and smaller shall be flexible type, square cut groove, per AWWA C606, and shall be Victaulic Style 77. Grooved-end couplings larger than 24-inches in diameter shall be Victaulic Style 44.

I. Outlets

1. Outlets 2-inches in Diameter and Smaller: Outlets of sizes 2-inches in diameter and smaller shall be of the "Thread-o-let" type, per AWWA Manual M-11. Outlets shall be 3,000-pound WOG forged steel per ASTM A105 or ASTM A216, Grade WCB. Threads shall comply with ASNI B2.1. Outlets shall be Bonney Forge Co. "Thread-o-let", Allied Piping Products Co. "Branch-let".
2. Outlets larger than 2-inches in Diameter: For outlets larger than 2-inches in diameter, flanged tees shall be used.

J. Length of Pipe Sections

Pipe sections shall be limited to 40 feet or less. For sections longer than 30 feet, spreader beams, and lifting straps shall be used to lift pipe sections at the third points.

K. Joints

1. Above Ground Joints: Joints above ground or in vaults and structures shall be flanged or grooved end, unless specifically indicated otherwise on the project plans.

2. Buried Joints: Buried joints shall be:
 - a. Bell-and-spigot lap welded.
 - b. Butt-strap joints. Closure pieces may also require butt-strap joints with "hand-holes" and threaded-steel plugs welded into place (for proper repair of the lining of the interior pipe joints.)
3. Grooved-End Joints: Grooved-end joints shall be flexible, square-cut grooved, per AWWA C606, Table 4.

L. Product Marking

Each length of straight pipe shall be plainly marked inside and out at the bell end to identify the design pressure or head, the steel wall thickness, the date of manufacture, and the proper location of the pipe item by reference to the layout schedule. For beveled pipe, the degree of bevel and the point on the circumference to be laid uppermost shall be shown.

M. Painting and Coating

1. General: Unless noted otherwise, buried pipe shall be cement-mortar coated per AWWA C205.
2. Exposed Pipe: Pipe located above ground or in vaults and structures shall be painted in accordance with Section 09900, Painting and Coating. Primer shall be shop applied.
3. Grooved-End Couplings: Grooved-end couplings shall be coated the same as the adjacent pipe.

N. Lining

Unless noted otherwise, pipe and fittings shall be cement-mortar lined per AWWA C205.

PART 3 - EXECUTION

A. Fabrication

1. Reference Standards: Fabrication shall comply with ANSI B31.3, Chapter V. Welding procedure and performance qualifications shall be in accordance with Section IX, Articles II and III, respectively, of the ASME Boiler and Pressure Vessel Code.
2. Welding
 - a. The pipe cylinder shall be fabricated by butt welding, spiral seam, or straight seam. Girth welds shall be limited to two per pipe section, butt welded. Longitudinal welds shall be limited to one seam. Longitudinal joints of adjacent shell courses shall be staggered.
 - b. For field welding, the shielded metal arc welding (SMAW) process shall be used. For the shop fabrication of special fittings and appurtenances, the submerged arc welding (SAW) process and the flux cored arc welding

(FCAW) process are acceptable alternates. All welding shall be done by qualified, certified welders.

- c. Welds shall be in accordance with ANSI B31.3, paragraph 327.4.
- d. Welding preparation shall comply with ANSI B31.3, paragraph 327.3. Limitations on imperfections in welds shall conform to the requirements in ANSI B31.3.
- e. For the SMAW process, welding electrodes shall comply with AWS A5.1. For the SAW process welding electrodes shall comply with AWS A5.17. For the FCAW process welding electrodes shall comply with AWS A5.20.
- f. Each layer of deposited weld metal shall be cleaned using a power-driven wire brush prior to depositing the next layer of weld metal. The final pass shall be cleaned by a power-driven wire brush.
- g. For field welds using the SMAW process, a minimum of three passes shall be used for welded joints on pipes 36-inches in diameter and larger. Welds shall be full circumferential.
- h. For controlled shop welding processes using SAW or FCAW, weld joints may be made with two passes.
- i. Beveled ends for butt welding shall conform to ANSI B16.25. Slag shall be removed by chipping or grinding. Surfaces shall be clean of paint, oil, rust, scale, slag, and other material detrimental to welding. When welding the reverse side, slag shall be chipped out before welding.

B. Joint Ring Protective Coating

The exposed portion of joint rings shall be coated with a 3-mil minimum thickness organic zinc pigmented coating meeting U.S. Federal Specification TT-P-641.

C. Shop Hydrostatic Test

The steel cylinder with joint rings shall be stressed to 75% of the minimum yield stress of the steel.

D. Shop Testing of Fittings

- 1. Dye Penetrant Test: Seams in fittings which have not been previously shop hydrostatically tested shall be tested by the dye penetrant method as described in ASME Boiler and Pressure Vessel Code Section VIII, Appendix B.
- 2. Air-Soap Test: In addition to the dye penetrant method of testing, the air-soap method with air at 5 psi shall be used on joints susceptible to being tested by such a method.
- 3. Pressure Test in Lieu of Dye Penetrant Test: In lieu of the dye penetrant method of testing, completed fittings may be hydrostatically tested using the field hydrostatic test pressure or 125% of the design pressure, whichever is higher.

E. Delivery of Small Parts

Small parts, consisting of gaskets, bolts, nuts, washers, jumper rods, and flange insulation kits, shall be delivered to the job site in suitable containers, each marked to identify the contents.

F. Installation

Pipe shall be installed in accordance with the requirements of Section 15051, Installation of Pressure Pipelines.

G. Field Inspection of Cement Mortar Lining and Interior Pipe Joints

The contractor shall perform closed circuit television (CCTV) inspection of the interior of all pipeline segments with diameters less than 30-inches; and for all sections of pipe, regardless of diameter, which are deemed not readily accessible for inspection by the District Representative. Interior pipe inspection shall be in accordance with the requirements of Section 15040, Interior Inspection for Cement-Mortar Lined Steel Pipe.

END OF SECTION

SECTION 15089: COMBINATION AIR RELEASE AND VACUUM RELIEF VALVES

PART 1 - GENERAL

A. Description

This section describes materials and installation of combination air release and vacuum relief valves, hereafter referred to as “valves”, for 4-inch and smaller valves used for potable and non-potable water systems.

B. Related Work Specified Elsewhere

1. Painting and Coating: 09900
2. Hydrostatic Testing of Pressure Pipelines: 15042
3. Manual Valves: 15100

C. Submittals

1. Shop drawings shall be submitted in accordance with the General Provisions and as specified herein.
2. Submit manufacturer's catalog data. Show dimensions, materials of construction by ASTM reference and grade, and protective coating and lining.

PART 2 - MATERIALS

A. Valves

1. Valves shall be 1-inch, 2-inch, 3-inch or 4-inch in diameter and shall include:
 - a. A float assembly and large venting orifice to exhaust large quantities of air from pipelines when being filled and to admit large quantities of air when pipelines are being drained. Valves shall have a body with a flanged or threaded top containing the air release orifice. The float shall rise with the water level in the valve body to close the orifice by sealing against a synthetic rubber seat. The float shall withstand an external pressure of 1,000 psig without collapsing.
 - b. 1-inch and 2-inch valves shall include a 3/8-inch threaded outlet with stainless steel plug in the top cover or near the bottom of the valve body. 3-inch and 4-inch valves shall include a 1-inch threaded outlet with stainless steel plug near the bottom of the valve body or on the side of the valve body above the minimum water level.

- Materials of construction for valves shall be as follows:

Item	Material	Specification
Body and cover	Cast iron, ductile iron, or stainless steel with reinforced nylon	Cast Iron: ASTM A126, Class B Ductile Iron: ASTM A536 60-40-18
Float	Stainless steel or foamed polypropylene	Stainless steel: AISI Type 316, ASTM A240 or A276 Foamed Polypropylene: ASTM-1895-89
Guide rod, guide bushings	Stainless steel	AISI Type 316, ASTM A240 or A276
Seat	EPDM	---
Valve trim	Stainless steel	AISI Type 316, ASTM A240 or A276
Cover bolts	Stainless steel	AISI Type 316, ASTM A193, GR B8M

- Valves shall be designed for an operating pressure of 150 psi unless otherwise specified in the plans or specifications. Valves shall be APCO 140C/150C series, A.R.I. D-040 ST, A.R.I. D-060-C HF, Crispin UL series, or Val-Matic Model 200C series.

B. Valve End Connections

- Applications: 1-inch and 2-inch valves shall have threaded ends at the bottom of the body. 3-inch and 4-inch valves shall have flanged ends.
- Threaded Connections: Threaded ends shall comply with ANSI B1.20.1.
- Flanged Connections: Flanges for Class 150 valves shall comply with ANSI B16.1, Class 125. Flanges for Class 300 valves shall comply with ANSI B16.1, Class 250.

C. Bolts and Nuts for Flanged Valves

- Bolts and nuts for flanged valves and flanges shall be Type 316 stainless steel conforming to ASTM A193, Grade B8M, for bolts and ASTM A194, Grade 8M, for nuts.
- Washers shall be provided for each nut, shall be of the same material as the nut, and shall be installed adjacent to the nut, between the nut and the flange.
- The length of each bolt or stud shall be such that between 1/4-inch and 1/2-inch will project through the nut when drawn tight.

D. Gaskets

Gaskets for flanged end valves shall be as described in the individual piping specifications.

E. Coating

Valves shall be coated on the exterior in accordance with Section 09900, Painting and Coating. Prime coat shall be shop-applied at the place of manufacture. Finish coat shall be applied in the field. Color of finish coat shall match the color of the adjacent piping.

F. Lining

Interior surfaces of the valves shall be coated in accordance with Section 09900, Painting and Coating, System No. G-1. Seating areas and plastic, stainless steel, or other high alloy parts shall not be coated.

G. Vented Cover

1-inch and 2-inch valves shall be enclosed inside a removable vented cover as shown in the IRWD Standard Drawings. Vented covers shall be manufactured of linear-low-density polyethylene (LLDPE) as made by Armorcast Products or by Pipeline Products, Inc. and the integral color shall be sandstone.

3-inch and 4-inch valves shall be enclosed inside a removable, cylindrically-shaped, vented cover fabricated of welded steel pipe, hot dip galvanized after fabrication and painted in accordance with Section 09900, Painting and Coating.

PART 3 - EXECUTION

A. Installation

Valves shall be installed in accordance with the IRWD Standard Drawings.

1. Tap: The tap for the valves shall be made in a level section of pipe no closer than 18 inches to a bell, coupling, joint, or fitting.
2. Threaded Connections: Threaded joints shall be cleaned by wire brushing or swabbing. Teflon joint compound or Teflon tape shall be applied to pipe threads before installing threaded valves. Joints shall be watertight.
3. Flanged Connections: Flanges shall be cleaned by wire brushing before installing flanged valves. Flange bolts and nuts shall be cleaned by wire brushing, and threads shall be coated with anti-seize compound. Nuts shall be tightened uniformly, and in the sequence pattern and torque setting recommended by the manufacturer. If flanges leak under pressure testing, nuts and bolts shall be loosened or removed, the gasket reseated or replaced, the bolts and nuts reinstalled or retightened, and joints retested. Joints shall be watertight.

B. Valve Pressure Testing

Valves shall be pressure tested at the same time that the connecting pipelines are pressure tested. See Section 15042, Hydrostatic Testing of Pressure Pipelines, for pressure testing requirements. Valves, operators, or control and instrumentation systems whose pressure rating is less than the test pressure shall be protected or isolated during pressure testing.

END OF SECTION

SECTION 15100: MANUAL VALVES

PART 1 - GENERAL

A. Description

This section describes materials, testing, and installation of manually operated valves and check valves.

B. Related Work Specified Elsewhere

1. Painting and Coating: 09900
2. Hydrostatic Testing of Pressure Pipelines: 15042

C. Submittals

1. Shop drawings shall be submitted in accordance with the General Provisions and as specified herein.
2. Submittals shall include the following information at a minimum. Factory signed and dated certification of compliance shall accompany all submittals. Signatures of agents or distributors of the factory will not be accepted.
 - a. Manufacturer's catalog data and detail construction sheets showing all valve parts and describing materials of construction by material and specification (such as AISI, ASTM, SAE, or CDA).
 - b. Valve dimensions including laying lengths.
 - c. Dimensions and orientation of valve actuators, as installed on the valves.
 - d. Valve linings and coatings.
 - e. Factory torque sheets minimally supplying actuator output and valve input torque requirements. Method for calculating input torque shall be the same as per AWWA Class 150B designation.
 - f. Manufacturer's warranty: Where electric motor actuators are used, the valve manufacturer shall include the electric motor actuator warranty and shall be the responsible party for both the valve and the electric actuator. Electric motor actuators shall be installed by the valve manufacturer to maintain both manufacturer warranties.

D. Valve Selection Criteria

Selection of the type of valve for a given application within IRWD's distribution and transmission system shall follow the criteria defined below.

Selection Criteria			
Nominal Valve Diameter (inches)	Normal System Static Pressure (0 to 100 psi)	Normal System Static Pressure (100 to 150 psi)	Normal System Static Pressure (150 to 250 psi)
3 and smaller	Ball	Ball	Ball
4	Gate	Butterfly	CL 250 Butterfly
6	Gate	Butterfly	CL 250 Butterfly
8	Gate	Butterfly	CL 250 Butterfly
10	Gate	Butterfly	CL 250 Butterfly
12 and larger	Butterfly	Butterfly	CL 250 Butterfly

PART 2 - MATERIALS

A. General

Valves shall be provided complete with operating hand-wheels, levers, chain-wheels, extension stems, floor stands, worm gear actuators, operating nuts, chains, and wrenches as required for operation.

Valves shall have the name of the manufacturer and the size of the valve cast or molded onto the valve body or bonnet or shown on a permanently attached corrosion-resistant plate.

B. Resilient Seated Gate Valves, 4-inch through 10-inch

Resilient seated wedge-type, gate valves shall conform to AWWA C509 and the following requirements.

1. Valves shall have a wedge-type resilient seat with the gate fully encapsulated in peroxide-cured EPDM rubber.
2. Valves shall be designed for a minimum working pressure of 200 psi. See Section 15112, Backflow Preventers, for resilient seated gate valves on backflow prevention assemblies.
3. Valves shall have non-rising stems fabricated of Type 304 or 316 stainless steel. As an alternate, stem material may be high strength bronze alloy. Stem nuts shall be independent of the gate and shall be made of bronze.

Materials of construction shall be as follows:

Component	Material	Specification
Body, Operating Nut, Bonnet, Seal Plate	Ductile Iron	ASTM A536, Grade 65-45-12
Gate	Ductile Iron	ASTM A536, Grade 65-45-12
Stem	Stainless Steel or high-strength, low zinc Bronze	AISI 430F; ASTM A582 or Type 316; ASTM B763, CDA 867
Stem Nut	Bronze	ASTM B62
Nuts & Bolts	Stainless Steel	ASTM A193/194, Type 316
Valve Seat	EPDM Rubber	ASTM D412
O-Rings	Synthetic Rubber	ASTM D2000

Low friction, torque reduction thrust bearings shall be provided both above and below the stem collar. Stuffing boxes shall be O-ring seal type with two rings located in stem above thrust collar.

Each valve shall have a smooth unobstructed waterway free from any sediment pockets.

Valves shall be American AVK, Clow RW, M&H Style 4067, Matco Norca, or Mueller A2362.

C. Butterfly Valves, 4-inch and Larger

Butterfly valves shall be short body, flanged type, conforming to AWWA C504, Class 150B. Wafer style valves shall not be used.

Unless otherwise noted, minimum working differential pressure across the valve disc shall be 150 psi.

Valve ends shall be as shown on the drawings and in all cases shall match the class rating of the valve. For example, Class 150 valves shall have 150-lb flanges and Class 250 valves shall have 250-lb flanges. Flanged ends shall be Class 125 drill pattern, ANSI B-16.1 unless otherwise specified. Note that all butterfly valves 8-inch in diameter and larger are required to have flanged ends to meet the requirements for valve leakage testing. Refer to Part 3, sub-section D, paragraph 2 for testing requirements.

Valve shafts shall be Type 304 or 316 stainless steel for Class 150 valves and 17-4 PH stainless steel for Class 250 valves. Valve shafts may be stub shaft or one-piece units extending completely through the valve disc.

Materials of construction shall be as follows:

Component	Material	Specification
Body	Ductile Iron	ASTM A536, Grade 65-45-12
Valve Shaft (CL 150)	Stainless Steel	Type 304 or Type 316
Valve Shaft (CL 250)	Stainless Steel	Type 17-4
Exposed body cap screws, bolts & nuts (including squeeze-pins)	Stainless Steel	ASTM A276, Type 316
Discs	Ductile Iron Stainless Steel	ASTM A536, Grade 65-45 Type 316
Valve Seat	EPDM Rubber	ASTM D412
O-Rings	Synthetic Rubber	ASTM D2000

The rubber seat shall be made from peroxide-cured EPDM rubber and shall be fastened integrally within the valve body. Rubber seats fastened to the disc by any means shall not be allowed.

Valves shall be Crispin K-Flo Series 47, 500, or L2, Dezurik BAW, Mueller Linesal, or Pratt Groundhog.

D. Other Valves

The following valves shall be used as specified in the Contract Documents.

1. Ball Valves, 3-inch and Smaller

Ball valves shall be used for non-buried valves 3-inch and smaller.

Ball valves for water service shall be the three-piece body style and shall be Type 316 stainless steel. Ball valves shall be NSF 61 certified. The minimum design operating pressure rating shall be 300 psi WOG at a temperature of 150° F.

Valves shall have plastic coated stainless steel lever actuators with a locking mechanism. Valves shall have full-bore ports, female iron pipe thread screwed ends, and non-blowout stems.

Materials of construction shall be as follows:

Component	Material	Specification
Body, Ball, Stem	Stainless Steel Brass	Type 316, ASTM A276 Lead Free Brass, C27451
Seat, Seals	Teflon	--

Valves shall be Apollo, Sharpe, Stockham Figure S-127, or Xomox.

2. Ball Valves, 4-inch through 12-inch

Ball valves 4-inch through 12-inch shall be rated for a minimum working pressure of 150 psi. Ball valves shall meet or exceed the requirements of AWWA C507 and shall have flanged ends. Valves shall have Proof of Design testing with documentation per AWWA C507.

Valves shall be of the "double-seated" style and shall provide drip-tight closure in both directions.

Materials of construction shall be as follows:

Component	Material	Specification
Body, Ball	Ductile Iron	ASTM A536, 65-45-12; ASTM A395/395M
Stem, Shaft	Stainless Steel	18-8 Type 304 or 17-4 Type 630
Seat, Seals	EPDM Rubber	--

External valve trim and all exposed threaded components shall be corrosion resistant alloys of stainless steel, Type 316L.

Valves shall be Jamesbury Series 9000, or Pratt rubber-seated.

3. Lubricated Plug Valves, 6-inch through 20-inch

Lubricated plug valves of sizes 6-inch through 20-inch shall have cast iron (ASTM A126, Class B) bodies and plugs. Valves shall be of the regular pattern with bolted glands and resilient packing. Plug coating shall be Teflon, permanently bonded to the plug. Unless noted otherwise on the drawings, valve ends shall be flanged, with face-to-face dimensions conforming to ANSI B-16.1, Class 125. Valve shall have a pressure rating of 200-psi WOG. Valves shall be enclosed worm gear operated and watertight for submerged service. Valves shall be lubricated with the manufacturer's recommended lubricant for cold-water service.

External valve trim and all exposed threaded components shall be corrosion resistant alloys of stainless steel, Type 316L.

Valves shall be Galli & Cassina or Nordstrom.

4. Eccentric Plug Valves, 4-inch through 12-inch

Eccentric plug valves of sizes 4-inch through 12-inch shall be of the non-lubricated type. Minimum pressure rating shall be 175 psi. Unless noted otherwise on the drawings, ends shall be flanged, Class 125 per ANSI B-16.1. Plugs shall be provided with Polytetrafluoroethylene (PTFE) grit excluders to protect the upper and lower journal bearings.

Materials of construction shall be as follows:

Component	Material	Specification
Body	Ductile Iron	ASTM A536, Grade 65-45-12
Plug	Ductile Iron	ASTM A536, Grade 65-45-12
Journal Bearings	Sintered Stainless Steel	ANSI 316

Plugs shall have neoprene, Buna-N facing to provide drip-tight shutoff.

Valve body seats shall have a raised welded-in overlay of not less than 90 percent nickel. Plug shall be of the one-piece design. Proof of design shall accompany submittals and leak tests shall accompany shipment.

External valve trim and all exposed threaded components shall be corrosion resistant alloys of stainless steel, Type 316L.

Valves shall be Dezurik Series 100 PEC or Pratt-Milliken 600 series.

5. Check Valves, 4-inch and Larger

- a. Swing Check Valves: Swing check valves shall conform to AWWA C508, and shall be iron body, mounted with the following materials of construction:

Component	Material	Specification
Disc	Ductile Iron	ASTM A536, Grade 65-45-12
Body and Cap	Ductile Iron	ASTM A536, Grade 65-45-12
Hinge or Arm	Cast Iron	ASTM A126, Class B
Hinge Pin	Stainless Steel	ASTM A276, Type 303, 304 or 410
Cover Bolts & Nuts	Stainless Steel	ASTM A193, Grade B8M; ASTM A194, Grade 8M

Ends shall be flanged, Class 125, ANSI B-16.1. Valves shall be designed for a minimum working pressure of 150 psi.

Except for the Val-Matic Surge Buster, valves shall be equipped with outside lever and spring.

Valves shall be Clow 1106 M&H Style 259, Pratt Series 8001, or Val-Matic Surge Buster 7200 MIBFS.

- b. Silent Check Valves, Class 150: Silent check valves shall be designed to be installed between the flanges of the adjoining pipe. Valves shall be equipped with a spring mechanism to provide for non-slam closure of the valve without backflow, in any position, and shall not be dependent on gravity or backflow for closure.

Materials of construction shall be as follows.

Component	Material	Specification
Body	Ductile Iron	ASTM A536, Grade 65-45-12
Disc	Aluminum bronze	ASTM B148
Spring, Pin, Stops	Stainless Steel	ANSI Type 316
Seat	EPDM Rubber	ASTM D412

Valves shall be APCO Series 600, Pratt Series 821, or Titan CV 50-DI-B.

6. Solenoid Valves, 1-1/2-inch and Smaller

Solenoid valves of sizes 1/4-inch through 1-1/2-inch for water and air service shall have forged brass (Alloy C-23000) or bronze (ASTM B62) bodies with Teflon main seats. Valve components in contact with potable water shall be NSF 61 certified. Internal plunger, core tube, plunger spring, and cage assembly shall be stainless steel (Types 302, 304, or 305). Solenoid enclosures shall be NEMA Type 4. Valve actuators shall be 120-volt AC or 24-volt DC as stated on the plans. Seals shall be Teflon. Valves shall have a maximum operating pressure and a maximum differential pressure of 250 psi.

Solenoid valves shall be energized to open or close, as required. Valves shall be ASCO "Red Hat", no equal.

7. Tapping Valves

Tapping valves shall conform with the requirements for resilient wedge gate valves 4-inch and larger. Valve ends shall be flanged, and the flange at one end shall have slotted bolt holes to fit standard tapping machines. Seat rings shall be oversized to permit the use of full-size cutters. Tapping valves shall be Kennedy or Mueller.

E. Valve Actuators

1. General Requirements for Gear Actuators

- a. Gear actuators shall be enclosed, suitable for operating in grease with seals provided on shafts to prevent entry of dirt and water into the actuator.
 - i. External trim and all threaded parts of the actuator shall be Type 316 stainless steel material.
- b. Gear actuators shall be of the totally enclosed design, proportioned to permit operation of the valve under full operating head in either direction, with a maximum pull of 80 pounds on the handwheel or with a maximum input of 150 ft-lbs applied to the AWWA wrench nut. Design and torque capacity shall consider flow and shut-off in "BOTH" directions.
- c. Actuators shall be provided with "open" and "closed" position stop limiting devices. Actuators shall be of the self-locking type to prevent the valve disc or plug from creeping.

2. Standard Opening Direction: Valve actuators, handwheels, or levers shall open by turning counterclockwise. (Commonly stated as, "open-left – close-right".)

3. AWWA Wrench Nut: Valves for buried and submerged applications shall be provided with a 2-inch square AWWA wrench nut. The wrench nut shall have an arrow cast thereon, indicating the direction of opening. The wrench nut shall be suitably fastened to the actuator input shaft. If the shaft is smooth, the wrench nut shall be fastened to the input shaft by means of a 5/16-inch diameter stainless steel pin passing entirely through the shaft and the wrench nut. Key with keyway shall also be acceptable. If the shaft is splined, the wrench nut shall be formed to fit the splined shaft.

- a. Operating Torque Requirement: The actuator shall be designed to produce the specified torque with a maximum input of 150 ft-lbs applied to the wrench nut (at the maximum rated pressure and a velocity of 16 cfs.)

4. Handwheels: Valves for aboveground applications shall be provided with a handwheel with a minimum diameter of 12-inches. The handwheel shall have an arrow thereon, indicating the direction of the opening. The handwheel shall be suitably fastened to the actuator input shaft.

- a. Operating Torque Requirement: Actuators equipped with handwheels shall be designed to produce the specified torque with a maximum pull of 80 pounds of the handwheel rim.

5. Position Indicators: Valve position indicators shall be provided for all above ground valves. Submerged and buried valves shall have a water tight seal plate in place of the valve position indicator. No rotating part indicating position shall be allowed for valves intended for buried service.
6. Operators for Exposed Valves Smaller than 6-inch: Unless otherwise called for on the plans or specifications, lever or wrench actuators having adjustable, open stop memory positions shall be provided for exposed valves smaller than 6-inch.
7. Actuators for Valves 4-inch and Larger
 - a. Butterfly Valves
 - i. 4-inch through 20-inch diameter butterfly valves shall have gear actuators of the "traveling nut type". Traveling nut actuators shall be furnished on all valves in this size range unless torque or pressure conditions dictate a "worm gear type".
 - ii. 24-inch through 54-inch diameter butterfly valves shall have gear actuators of the "worm gear type". Worm gear actuators shall be furnished on all valves in this size range.
 - b. Ball and Plug Valves
 - i. Ball and plug valves 6-inch and larger shall have actuators of the "worm gear type"
8. Requirements for Traveling Nut Gear Actuators
 - a. Traveling nut actuators shall withstand 450 foot pounds of input torque against the stop limiting devices without causing damage.
 - b. Signed factory compliance shall accompany submittals stating that these specifications and applicable standards have been adhered to.
 - c. All exposed threaded parts, including cap screws, case bolts, carriage bolts, cover screws, machine screws, set screws, bonnet bolts on the housing or any other exterior location on the actuator, its cover or housing shall be Type 316 stainless steel.
 - d. Traveling nut type gear actuators shall be able to rotate the valve element (disc, plug, or ball) from the fully "closed" position to the fully "open" position with a number of turns of the actuator nut or wheel. For 4-inch through 10-inch valves, the number of turns shall not be fewer than twenty nine (29) turns. For 12-inch through 20-inch valves, the number of turns shall not be fewer than twenty nine (29) turns and not more than three (3) times the number of diameter inches.
 - i. Where the number of turns may fall outside of the range for turn limits, the use of a factory attached spur gear reducer shall be used to provide the appropriate number of rotations from the fully "open" to the fully "closed" position. Spur gear assemblies shall be mounted integrally to the actuator by approved means and shall

meet all of the other component and torque requirements listed herein.

- e. Actuators shall be Dezurik M-Series, Crispin TNA, Mueller MDT, or Pratt MDT.
- f. Refer to the following table for actuator selection and characteristics for traveling nut gear operators for 150 and 250 psi:

Valve Actuator Selection – Traveling Nut				
Nominal Valve Diameter (inches)	IRWD Specified Range of Valve Turns (number)	Dezurik Actuator Model	Mueller Actuator Model	Pratt Actuator Model
4	29	MB-3	MDT-2S	MDT2S
6	29	MB-3	MDT-2S	MDT2S
8	29	MB-3	MDT-2S	MDT2S
10	29	MB-3	MDT-3S	MDT-3S
12	29 - 36	MB-3	MDT-3S	MDT-3S
14	29 - 42	MB-3	MDT-3S	MDT-3S
16	29 - 48	MB-7	MDT-4S	MDT-4S
18	29 - 54	MB-7	MDT-4S	MDT-4S
20	29 - 60	MB-7	MDT-5	MDT-5

9. Requirements for Worm Gear Actuators

- a. Worm gears shall be of the "self-locking" one-piece design of gear bronze material (ASTM B427), accurately machine cut.
- b. The worm shall be hardened alloy steel (ASTM A322, Grade G 41500; or ASTM A148, Grade 105-85), with threads ground and polished.
 - i. The reduction gearing shall run in a proper lubricant inside a ductile iron housing.
- c. All exposed (at the exterior of the actuator) threaded parts, including cap screws, case bolts, carriage bolts, cover screws, machine screws, set screws, bonnet bolts on the housing or any other exterior location on the actuator, its cover or housing shall be Type 316 stainless steel.
- d. Actuator components shall be designed to withstand a pull of 200 pounds for handwheel or chain wheel actuators between the input and stop limiting devices without damage, and an input torque of 300-foot-pounds for operating nuts when operating against the stops.
- e. Gear actuators shall be able to rotate the valve element (disc, plug, or ball) from the fully "closed" position to the fully "open" position with a number of turns of the actuator nut or wheel, not fewer than one-and-a-half (1.5) times the number of diameter inches and not more than three (3) times the number of diameter inches.

- i. Where the number of turns may fall outside of the range for turn limits, the use of a factory attached spur gear reducer shall be used to provide the appropriate number of rotations from the fully "open" to the fully "closed" position. Spur gear assemblies shall be mounted integrally to the actuator by approved means and shall meet all of the other component and torque requirements listed herein.
- f. Actuators shall be Auma GS Series, EIM Model WB Series, or Limitorque Model HBC or PT Series, no equals.
- g. Refer to the following tables for actuator selection and characteristics for worm gear actuators for 150 psi valves and for 250 psi valves:

150 psi Valve Actuator Selection – Worm Gear							
Nominal Valve Diameter (inches)	IRWD Specified Range of Turns (number)	AUMA Make & Model [model/gear]	Turns Open - Close (number)	EIM Actuator Make & Model	Turns Open - Close (number)	Limitorque Make & Model [model/gear]	Turns Open - Close (number)
24	36 - 72	GS125.3	* 13	EIM WB52	64	PTA30/3.5	60
30	45 - 90	GS 160.3/GZ 160.3 4:1	* 54.5	EIM WB52	64	PTA65/3.1	47
36	54 - 108	GS 160.3/GZ 160.3 4:1	* 54.5	EIM WB54	70	PTA120/6.3	95
42	63 - 126	GS 200.3/GZ 200.3 8:1	* 108.5	EIM WB54	70	PTA120/6.3	95
48	72 - 144	GS 250.3/GZ 250.3 8:1	* 103	EIM WB65	* 148	PTA250/6	96
54	81 - 162	GS 250.3/GZ 250.3 8:1	* 103	EIM WB65	148	PTA250/18	* 288
250 psi Valve Actuator Selection – Worm Gear							
Nominal valve diameter (inches)	IRWD Specified Range of Turns (number)	AUMA Make & Model [model/gear]	Turns open - close (number)	EIM Actuator Make & Model	Turns open - close (number)	Limitorque Make & Model [model/gear]	Turns open - close (number)
24	36 - 72	GS125.3	* 13	EIM WB52	64	PTA30/3.5	60
30	45 - 90	GS 160.3/GZ 160.3 4:1	* 54.5	EIM WB52	64	PTA65/3.1	47
36	54 - 108	GS 160.3/GZ 160.3 4:1	* 54.5	EIM WB54	70	PTA120/6.3	95
42	63 - 126	GS 200.3/GZ 200.3 8:1	* 108.5	EIM WB65	* 148	PTA120/6.3	95
48	72 - 144	GS 250.3/GZ 250.3 8:1	* 103	EIM WB65	* 148	PTA250/6	96
54	81 - 162	GS 250.3/GZ 250.3 8:1	* 103	EIM WB74	* 270	PTA250/18	* 288

* Indicates number of turns does not meet IRWD requirement and spur-gear reduction is required to correct. Spur-gear submittal is required. See paragraph 9.e.i above.

F. Valve Boxes, Risers, and Lids for Buried Valves

1. General

Valve riser shall be 8-inch SDR 35 PVC pipe.

2. Manufacturers

Valve boxes for potable water lines shall be round in shape and shall be Bingham & Taylor Mark V, Brooks 3-RT, Eisel Enterprises, Inc. No. 10 or National Casting Corporation NC 202.

Valve boxes for recycled and raw water lines shall be triangular in shape and shall be Bingham & Taylor Mark VTB, Brooks 4-TT or Eisel Enterprises, Inc. 4TT.

The Contractor shall use Bingham & Taylor or National Casting Corporation valve boxes, no equal, for projects on arterial roadways consisting of two or more lanes in each direction. Pavement restoration work that requires replacing existing valve boxes to grade shall use only Bingham & Taylor or National Casting Corporation valve boxes, no equal, unless said boxes are already installed, in which case, they shall be reused if the valve box is in acceptable condition as determined by the District Representative.

3. Valve Boxes

Valve box lids shall be cast-iron and shall be designed to rest with or without a frame on a cast-in-place concrete ring surrounding the valve extension pipe. The lids shall be in accordance with IRWD Standard Drawing W-22.

Brooks 3-RT and Eisel Enterprises: The lid skirt shall be 6 inches deep. The minimum weight of nominal 10-inch lid shall be a minimum of 28 pounds for circular valve covers and a minimum of 17 pounds for triangular valve covers. Lids shall be coated per Section 09900, Painting and Coating.

Bingham & Taylor and National Casting Corporation: The lid skirt shall be 4 3/8-inch inches deep. The minimum weight of nominal 10-inch lid shall be a minimum of 20 pounds for circular valve covers and a minimum of 20 pounds for triangular valve covers. Lids and frame shall be coated per Section 09900, Painting and Coating.

G. Extension Stems for Buried Valve Operators

Where the depth of the valve is such that its operating nut is more than 7 feet below finished grade, operating extension stems shall be provided to bring the operating nut to a point as shown on the IRWD Standard Drawing W-23.

Extension stems shall be solid steel bar stock, and shall be complete with 2-inch square operating nut.

No pinned couplings are permitted.

Extension stems shall conform to IRWD Standard Drawings.

H. Bolts, Nuts, and Washers for Flanged Valves

1. Bolts and nuts for flanged valves and flanges shall be Type 316 stainless steel conforming to ASTM A193, Grade B8M, for bolts and ASTM A194, Grade 8M, for nuts.
2. Washers shall be provided for each nut, shall be of the same material as the nut, and shall be installed adjacent to the nut, between the nut and the flange.
3. The length of each bolt or stud shall be such that between 1/4-inch and 1/2-inch will project through the nut when drawn tight.

I. Gaskets for Valves

Gaskets for flanged end valves shall be as described in the individual piping specifications.

J. Painting and Coating for Valves and Extensions

1. Exterior Coating

Metal valves (except bronze and stainless steel valves) shall be coated in accordance with Section 09900, Painting and Coating, and shall be holiday free.

- a. The specified prime coat shall be applied at the place of manufacture.
- b. Finish coat shall match the color of the adjacent piping.
- c. Exposed portions of the valve shaft shall not be coated.

2. Interior Coating

Metal valves shall be coated on the interior metal parts, excluding seating areas and bronze and stainless steel pieces, per Section 09900, Painting and Coating, System No. G-1 or System No. G-2.

- a. Coating shall be factory applied by the valve manufacturer.
- b. Valve coatings will be field spark tested and shall be holiday-free.

PART 3 - EXECUTION

A. Joints

1. Flanged Joints: Bolt holes of flanged valves shall straddle the horizontal and vertical centerlines of the pipe run to which the valves are attached. Flanges shall be cleaned by wire brushing before installing flanged valves. Flange bolts and nuts shall be cleaned by wire brushing, threads shall be lubricated with anti-seize compound, and nuts shall be tightened uniformly and progressively.

If flanges leak under pressure testing, nuts and bolts shall be loosened or removed, the gasket shall be reseated or replaced, the bolts and nuts shall be reinstalled or re-tightened, and the joint retested. Joints shall be watertight.

2. Threaded Joints: Threaded joints shall be cleaned by wire brushing or swabbing. Teflon joint compound or Teflon tape shall be applied to pipe threads before installing threaded valves. Joints shall be watertight.

B. Valve Installation

1. Valves in Vertical Piping: Valves on vertical runs of pipe that are next to walls shall be installed with their stems horizontal, away from the wall. Valves on vertical runs of pipe that are not located next to walls shall be installed with their stems horizontal, oriented to facilitate valve operation.
2. Buried Valves: Buried valves shall be wrapped with two layers of 8-mil polyethylene wrap per AWWA C105.
3. Valve Supports: Valves shall be anchored in concrete as shown on IRWD Standard Drawing W-16 or on the valve detail drawings. Supports are not required for buried valves bolted to flanged pipe or other fixed or supported fittings. Supports shall be installed prior to pressurizing the system.

C. Valve Boxes

Valve boxes shall be firmly supported and shall be kept centered and plumb over the operating nut of the valve.

Beveled sections of pipe shall not be allowed at the top of the valve riser pipe. The top cut shall be square and machine made.

In new tracts, and where pavement has not been placed, the valve extension risers for "key valves" shall extend well above the ground level to permit ease of location in the event of the need for emergency shut-off. The final valve box elevation shall be flush with the finished pavement surface, or at the level shown on IRWD Standard Drawing W-22.

D. Valve Leakage Testing

1. Field Hydrostatic Testing

Valves shall be tested for leakage at the same time that the connecting pipelines are hydrostatically tested. See Section 15042, Hydrostatic Testing of Pressure Pipelines, for pressure testing requirements.

2. Pressure Testing

All butterfly valves 8-inch in diameter and larger, shall be flanged to facilitate testing. Valves 8-inch through 30-inch in diameter shall be tested in a horizontal position. Valves 36-inch in diameter and larger shall be tested in the vertical position (valve flange face oriented 90 degrees from the horizontal ground surface plane; with the shaft axis parallel to the ground).

All valves shall be tested bi-directionally after the actuator is installed and the adjustment stops are set. Each side of the valve shall be tested for a duration of at least 5 minutes at the pressure class rating of the valve with zero loss or leakage. Valve bodies shall be tested at a pressure equal to twice the design working pressure.

The pressure test shall be witnessed by the District Representative. Final tests shall be performed at the project site. The Contractor shall provide a minimum of 72 hours' notice to the District in advance of the pressure test.

Factory hydrostatic testing shall be conducted in advance of the final leakage testing. The District shall be given an opportunity to send a representative to witness the factory test. The Contractor shall notify the District Representative in writing 28 days in advance of all factory leakage tests.

END OF SECTION

SECTION 15112: BACKFLOW PREVENTERS

PART 1 - GENERAL

A. Description

This section includes materials, installation, and testing of backflow prevention assemblies.

B. Submittals

1. Shop drawings shall be submitted in accordance with the General Provisions and as specified herein.
2. Submit certification showing that the backflow device is approved by the Foundation for Cross-Connection Control and Hydraulic Research, University of Southern California, School of Engineering.

PART 2 - MATERIALS

A. Backflow Prevention Assembly

Backflow prevention assemblies shall conform to the latest editions of AWWA C510 or C511 and the "Manual of Cross-Connection Control", Foundation for Cross-Connection Control and Hydraulic Research, University of Southern California, School of Engineering.

B. Double Check Backflow Assembly

Prior to placing the backflow prevention assembly into service, the Contractor shall submit a fire line meter application to the District for the by-pass meter.

PART 3 - EXECUTION

A. Installation

Installation shall comply with the requirements of the IRWD Standard Specifications and Standard Drawings and the latest edition of the Manual of Cross-Connection Control, and with the latest plumbing codes and applicable local agency requirements.

B. Testing

Prior to being placed in service, a test shall be performed and a certificate of adequacy and operational compliance shall be furnished to the District. The test shall be performed by an approved tester by the Orange County Health Care Agency.

END OF SECTION

SECTION 15120: HYDRAULICALLY CONTROLLED DIAPHRAGM-ACTUATED VALVES

PART 1 - GENERAL

A. Description

This section describes materials and installation of hydraulically controlled diaphragm-actuated valves acting as pressure reducing valves, pressure sustaining valves, solenoid control valves, booster pump control valves, and altitude valves.

B. Related Work Specified Elsewhere

1. Painting and Coating: 09900
2. Hydrostatic Testing of Pressure Pipelines: 15042

C. Submittals

1. Shop drawings shall be submitted in accordance with the General Provisions and as specified herein.
2. Submit dimensional drawings for each size and type of valve provided.
3. Provide listing of materials of construction, with ASTM reference and grade. Show valve lining and paint primer coating with coating manufacturer and coating system number or designation.
4. Submit electrical drawings, (including P&ID's) showing wire and terminal connections, for valves that are electrically controlled.
5. Submit manufacturer's recommended maximum operating pressure and minimum and maximum recommended flows.

PART 2 - MATERIALS

A. Valve Design

1. **General:** Valves shall be hydraulically actuated diaphragm type. The body shall contain a removable seat insert. A resilient rubber disc shall form a drip-tight seal with the valve seat when pressure is applied above the diaphragm. The diaphragm assembly shall form a sealed chamber in the upper portion of the valve, separating operating pressure from line pressure.
2. **Component Parts:** The pilot control system shall include a fixed or variable orifice, and all major components of this system, except solenoid pilots, shall be manufactured by the same company that manufactures the main valve.

Elastomers shall be EPDM rubber material. The diaphragm shall not be used as a seating surface.

The valve stem shall be center guided or top and bottom guided. The stem orientation is to be vertical. For top and bottom stem guides, bearings in the valve

cover and in the valve seat shall be provided. For center guided valve stems, a bearing in the valve cover shall be provided. Stem sleeves or bearings shall have an anti-scale treatment or other approved friction reducing surface.

A valve position limit switch shall be provided.

Repairs and modification other than the replacement of the main valve body shall be possible without removing the main valve from the line.

B. Valves

1. Class 125 (150 psi) or Class 250 (300 psi) Pressure-Reducing Valves: Pressure reducing valves shall automatically maintain a constant downstream pressure regardless of changing flow rates and/or varying inlet pressures. The pilot control shall be direct-acting, spring loaded, diaphragm valve, designed to permit flow when controlled pressure is less than the spring setting. The pilot control system shall be provided with a strainer, isolation valves, opening speed control, closing speed control, and, where required for low flow, a flow stabilizer or V-port throttling plug. Initial pressure settings shall be coordinated with the District prior to placing the valve into service. The valve shall be globe pattern Cla-Val 90-01 Series or Ames ACV 910 Series "Mustang Valve" and there is no equal.
2. Class 125 (150 psi) or Class 250 (300 psi) Pressure Sustaining or Pressure Relief Valves: Pressure sustaining/relief valves shall maintain a constant upstream pressure by relieving excess pressure without causing surges. The pilot control system shall operate such that as excess line pressure is dissipated, the valve shall slowly close. The pilot control shall be a direct acting, spring-loaded, diaphragm valve, designed to permit flow when controlling pressure exceeds a spring setting. The pilot control system shall be provided with a strainer, isolation valves, opening speed control (pressure sustaining valves only), and closing speed control. Initial pressure settings shall be coordinated with the District prior to placing the valve into service. The valve shall be globe pattern Cla-Val 50-01 Series or Ames ACV 920 Series "Mustang Valve" and there is no equal.
3. Class 125 (150 psi) or Class 250 (300 psi) Solenoid Control Valves: Solenoid control valves shall provide on or off service for controlling flow. The pilot control shall be a three-way solenoid valve as specified herein. The pilot control system shall be provided with strainers, isolation valves, opening speed control, and closing speed control. Initial pressure settings shall be coordinated with the District prior to placing the valve into service. The valve shall be globe pattern Cla-Val Series 136-03 or Ames ACV 300 Series, "Mustang Valve" and there is no equal.
4. Class 125 (150 psi) or Class 250 (300 psi) Booster Pump Control Valve: Booster pump control valves shall be designed for installation on the discharge of booster pumps to eliminate pipeline surges caused by starting and stopping of pumps. Control of valve operation shall be by means of an externally mounted solenoid pilot valve. The solenoid pilot valve shall be as specified herein. Self-cleaning strainers shall be used to protect the control system. Valves shall utilize line pressure for operation. A limit switch shall be provided to be adjustable over entire valve travel. Valve shall be equipped with a check feature to prevent reversal of flow. The valve shall be globe pattern Cla-Val 60-11 Series or ACV 980 Series "Mustang Valve" and there is no equal.

5. Class 125 (150 psi) or Class 250 (300 psi) Altitude Valve: Altitude valves shall be designed to control the high water level in reservoirs. The valve shall be a non-throttling type, remaining fully open until the set-point in the reservoir is reached. Unless noted otherwise, the valve shall provide one-way flow, opening when the water level in the reservoir lowers below the set-point level, and shall be equipped with a check feature to prevent reverse flow. The pilot control shall be a three-way diaphragm valve that operates on the differential force between the height of the water in the reservoir and an adjustable spring load. The valve shall be globe pattern Cla-Val 210 Series or Ames ACV 960 Series, "Mustang Valve" and there is no equal.

C. Materials of Construction

Materials of construction for Class 125 and Class 250 valves shall be as follows:

<u>Item</u>	<u>Material</u>
Main valve body and cover	Ductile Iron, ASTM A536 Grade 60-40-18
Main valve trim and seat	Type 303 Stainless Steel, ASTM A276, or A 351
Pilot control system	Type 303 Stainless Steel, ASTM A276, or A 351
Piping and tubing	Type 303 Stainless Steel, ASTM A276, or A 351
Bonnet studs	Type 304 Stainless Steel
Bonnet nuts & Body plugs	Type 316 Stainless Steel

D. Valve End Connections

1. Applications: 1-inch and 2-inch valves shall have threaded ends at the bottom of the body. 3-inch and 4-inch valves shall have flanged ends.
2. Threaded Connections: Threaded ends shall comply with ANSI B1.20.1.
3. Flanged Connections: Flanges for valves shall be ductile iron meeting the requirements of ASTM A536. Flanges shall be Class 125 flanges (for 150 psi) and Class 250 flanges (for 300 psi) conforming to ANSI B16.1.

E. Bolts, Nuts, and Washers for Flanged Valves

1. Bolts and nuts for flanged valves and flanges shall be Type 316 stainless steel conforming to ASTM A193, Grade B8M, for bolts and ASTM A194, Grade 8M, for nuts.
2. Washers shall be provided for each nut, shall be of the same material as the nut, and shall be installed adjacent to the nut, between the nut and the flange.

3. The length of each bolt or stud shall be such that between 1/4 inch and 1/2 inch will project through the nut when drawn tight.

F. Gaskets

Gaskets for flanged end valves shall be as described in the individual piping specifications.

G. Coating

Valves shall be coated on the exterior in accordance with Section 09900, Painting and Coating. Prime coat shall be shop-applied at the place of manufacture. Finish coat shall be applied in the field. Color of finish coat shall match the color of the adjacent piping.

H. Lining

Interior surfaces of the valve shall be coated in accordance with Section 09900, Painting and Coating, System No. G-1. Seating areas, stainless steel, or other high alloy parts shall not be coated.

PART 3 - EXECUTION

A. Installation

1. Threaded Connections: Threaded joints shall be cleaned by wire brushing or swabbing. Teflon joint compound or Teflon tape shall be applied to pipe threads before installing threaded valves. Joints shall be watertight.
2. Flanged Connections: Flanges shall be cleaned by wire brushing before installing flanged valves. Flange bolts and nuts shall be cleaned by wire brushing, and threads shall be coated with anti-seize compound. Nuts shall be tightened uniformly, and in the sequence pattern and torque setting recommended by the manufacturer. If flanges leak under pressure testing, nuts and bolts shall be loosened or removed, the gasket reseated or replaced, the bolts and nuts reinstalled or retightened, and joints retested. Joints shall be watertight.

B. Valve Pressure Testing

Valves shall be pressure tested at the same time that the connecting pipelines are pressure tested. See Section 15042, Hydrostatic Testing of Pressure Pipelines, for pressure testing requirements. Valves, operators, or control and instrumentation systems whose pressure rating is less than the test pressure shall be protected or isolated during pressure testing.

END OF SECTION

SECTION 15139: HYDRANTS

PART 1 - GENERAL

A. Description

This section includes materials, installation, and testing of wet-barrel type fire hydrants for potable water and wharf type hydrants for recycled water.

B. Related Work Specified Elsewhere

1. Trenching, Backfilling, and Compacting: 02223
2. Concrete: 03300
3. Painting and Coating: 09900
4. Hydrostatic Testing of Pressure Pipelines: 15042
5. Ductile Iron Pipe and Fittings: 15056
6. Copper Pipe and Fittings: 15057
7. Manual Valves: 15100

C. Submittals

Shop drawings shall be submitted in accordance with the General Provisions and as specified herein.

PART 2 - MATERIALS

A. Fire Hydrants for Potable Water System

1. Fire Hydrant Top Section
 - a. General: Fire hydrants shall be of the wet-barrel type, with individual valves for each outlet, and shall conform to the requirements of AWWA C503.
 - b. Outlets: Fire hydrants for residential shall have one 2 1/2-inch outlet and one 4-inch outlet. Fire hydrants for industrial or commercial shall have one 2 1/2-inch inch outlet and two 4-inch outlets. All outlets shall be removable and have National Standard Hose Threads.
 - c. Materials of Construction: The fire hydrant top section shall be manufactured of bronze conforming to ASTM B62 or type 304 stainless steel conforming to CF-8 ASTM A351. All interior working parts, including stems, shall be of bronze containing no more than 7% zinc or 2% aluminum.

- d. Operating Nuts: Fire hydrants shall be provided with 1 1/2-inch sized pentagon-shaped operating nut and 1 1/2-inch cap nuts.
 - e. Outlet Caps: Plastic outlet nozzle caps shall be provided for all outlets.
 - f. Flanges: Fire hydrant flanges shall be drilled with a 6-hole pattern. The flange shall be drilled with 3/4-inch diameter holes located on a 9 3/8-inch bolt circle.
 - g. Breakaway Check Valve: Hydrant breakaway check valve, as manufactured by Hydrant Guard, shall be installed where called for on the plans.
 - h. Manufacturer Identification: Fire hydrants shall have the name of the manufacturer cast or welded onto the fire hydrant body.
2. Bury Section
- a. Materials: The bury section shall be ductile iron and shall be cement lined in conformance with Section 15056, Ductile Iron Pipe and Fittings.
 - b. Inlet Connection: Inlet size shall be a 6-inch push-on joint for short-side hydrant installations and shall be 6-inch flanged for long-side hydrant installations, unless otherwise specified on the plans.
 - c. Bury Depth: Bury depth shall be 42-inches for distribution mains and 48-inches for transmission mains. Field conditions may require different depth fire hydrant buries to fit abnormal pipe, as approved by the District Representative.
 - d. Flanges: Bury flanges shall be drilled with a 6-hole pattern. The flange shall be drilled with 3/4-inch diameter holes located on a 9 3/8-inch bolt circle.
 - e. Break-Away Spools: Cast iron break-away spools shall be provided for each hydrant installation as shown on the IRWD Standard Drawings. Each spool shall have a scored groove placed circumferentially around the spool near the hydrant end of the spool. The score shall be placed above-grade. Only one score shall be made in the hydrant break-away spool piece. Spool flanges shall be a 6-hole pattern to match both the hydrant and the bury.
 - f. Approved Manufacturers: Bury and extension sections shall be as manufactured by Clow, Tyler, or South Bay Foundry.
3. Break-Away Bolts: Zinc-plated carbon steel alloy break-away bolts in accordance with ASTM A307 that are silicon filled shall be used to join the break-away spool section to the hydrant top section. Steel SAE washers shall be placed between the hydrant flange and the zinc-plated nuts.

4. Isolation Valve: The isolation valve on the fire hydrant assembly shall be a gate valve per Section 15100, Manual Valves.
5. Gaskets: Gaskets shall be full face 1/8-inch thick and of rubber composition. Full face type gaskets with pre-punched holes shall be used where both flanges are flat face. Ring gaskets extending to the inner edge of the bolts may be used where a raised face flange is present.
6. Manufacturers
 - a. Residential Use: For residential applications, fire hydrants shall be American AVK Company Series 24, Clow El Rancho Series Model 2050, or James Jones 3700R (Hydrant Head and Fluted Spool).
 - b. Commercial and Industrial Use: For commercial and industrial applications, fire hydrants shall be American AVK Company Series 24, Clow Model No. 2065, or James Jones 3775R (Hydrant Head and Fluted Spool).

B. Hydrants for Recycled Water System

1. Hydrant Top Section
 - a. General: The hydrant shall consist of a riser with a threaded wharf head angle plug valve.
 - b. Outlets: Hydrants shall have one 2 1/2-inch outlet. Outlet shall be removable and have National Standard Hose Threads.
 - c. Materials of Construction: The wharf head angle plug valve shall be bronze.
 - d. Operating Nuts: Hydrants shall be provided with 1 1/2-inch sized pentagon-shaped operating nut and 1 1/2-inch capnuts. The operating nut shall be affixed to the bonnet by means of an ASTM B584 bronze hold down nut. The hold down nut shall be threaded into the bonnet in such a manner as to prevent accidental disengagement during the opening cycle of the hydrant.
 - e. Operating Stem: The operating stem shall consist of one or two pieces and shall be made of an ASTM A107 or A576 type steel.
 - f. Outlet Caps: Plastic or bronze outlet nozzle caps shall be provided for outlet and shall include a nozzle cap chain.
 - g. Flanges: Hydrant flanges at the base of the hydrant shall be drilled with a 8-hole pattern. The flange shall be drilled with 3/4-inch diameter holes.
 - h. Manufacturer Identification: Hydrants shall have the name of the manufacturer cast or welded onto the hydrant head.

2. Piping Section
 - a. Materials: The piping and elbow shall be ductile iron ASTM A536.
 - b. Depth: The depth shall be as shown on the IRWD Standard Drawings. Field conditions may require different depths and shall be approved by the District Representative.
 - c. Flanges: The flanges on the spools shall be drilled with a 8-hole pattern and with 3/4-inch diameter hole.
3. Isolation Valve: The isolation valve on the hydrant assembly upstream of the shoe shall be a gate valve per Section 15100, Manual Valves.
4. Gaskets: Gaskets shall be full face 1/8-inch thick and of rubber composition. Ring gaskets extending to the inner edge of the bolts may be used where a raised face flange is present. O-ring gaskets shall be rubber composition.
5. Manufacturer: Hydrant heads shall be James Jones J-344HP.

PART 3 - EXECUTION

A. General

Hydrant assemblies shall be installed in accordance with IRWD Standard Drawings, detail drawings, and as specified herein.

B. Location

Hydrant assemblies shall be located as shown on IRWD Standard Drawings, or as approved by the District Representative.

C. Valve and Valve Box

The valve and valve box shall be installed in accordance with Section 15100, Manual Valves.

D. Break-Away Bolts

Break-away bolts shall be installed with the threads toward the top of the hydrant. Bolts shall be packed with clear silicon sealant.

E. Concrete

The concrete pad and thrust blocks shall be Class C concrete placed per Section 03300, Concrete.

F. Painting

All above ground portions of the hydrant, bury, and flanged spools shall be painted in accordance with Section 09900, Painting and Coating.

G. Testing

Hydrants shall be tested at the same time that the connecting pipeline is pressure tested. See Section 15042, Hydrostatic Testing of Pressure Pipelines, for pressure testing requirements.

END OF SECTION

SECTION 15150: METERS

PART 1 - GENERAL

A. Description

This section describes the materials, installation, and testing of meter assemblies.

B. Related Work Specified Elsewhere

1. Structure Earthwork: 02220
2. Concrete: 03300
3. Precast Concrete Vaults and Meter Boxes: 03462
4. Painting and Coating: 09900
5. Hydrostatic Testing of Pressure Pipelines: 15042
6. Installation of Pressure Pipelines: 15051
7. Ductile-Iron Pipe and Fittings: 15056
8. Copper Pipe and Fittings: 15057
9. Manual Valves: 15100

C. Submittals

Shop drawings shall be submitted in accordance with the General Provisions and as specified herein.

D. Measurement and Payment

1. For contracts between Contractor and District, payment for the work in this section shall be in accordance with the General Provisions.
2. For contracts between Contractor and an entity (Developers, other agencies, etc.) other than the District, meters shall be furnished in accordance with the requirements of the District's Procedural Guidelines and General Design Requirements.

PART 2 - MATERIALS

A. General

This specification covers Positive Displacement Meters, Single-Jet Meters, and Turbine Meters. Compound Meters shall not be allowed for any applications. Positive Displacement Meters shall be used for small diameter applications (5/8-inch through 2-inch) requiring very accurate low-flow ranges. For larger metered connections (2-inch through 10-inch), low-flow applications (non-irrigation) shall be metered with Single-Jet

Meters, high-flow and continuous average flow applications (such as irrigation) shall be metered with Turbine Meters.

All meters shall be new and of current design, and all parts of the meters of the same size and model shall be interchangeable. All meters shall be NSF 61 approved.

B. Register

1. Reading Dials: Register shall have straight reading dial with 360° test circle(s), sweep hand(s), and low flow (leak) detector.
2. Registration Units: Register shall be calibrated to read in cubic feet increments. 5/8-inch, 3/4-inch, and 1-inch meters shall measure at a minimum 1 cubic foot volume per sweep hand revolution. 1 1/2-inch through 6-inch, meters shall measure at a minimum 10 cubic feet volume per sweep hand revolution.
3. Totalizer Display: Register shall be direct read and shall measure volume in cubic-foot increments. 5/8-inch, 3/4 inch, and 1-inch meters shall totalize in 1 cubic-foot increments; 1 1/2-inch through 6-inch meters shall totalize in 100 cubic-foot increments. This may require the stamping of a zero or zeroes on the register dial face. The last two digits including the zero or zeroes stamped on the register dial face shall be easily distinguishable from the balance of the digits either by contrast of white numbers on black, red numbers on white, or silver numbers on black.
4. Registers: Registers for all meters shall be hermetically sealed, and shall not have replaceable change gears.
5. Gears: Register gears shall be self-lubricating molded plastic or brass unless stated otherwise.
6. Drives: Registers shall be driven by magnetic coupling or directly shaft driven.
7. Lenses: All register lenses shall be tempered glass.
8. Serial Number: The serial number of each meter shall be imprinted on both the register box cover and the main casing.

C. End Connections

Unless otherwise specified herein, all meters shall have standard flanged connections, with Type 316 stainless steel bolts, nuts, capscrews, studs, and washers.

D. Positive Displacement Meters (5/8-Inch through 2-Inch)

1. General: Meters shall conform to the material and performance requirements of AWWA C700 as applicable and the specifications herein.
2. Certification: The manufacturer shall furnish certified results for each meter showing that it has been tested for accuracy of registration according to the manufacturer specifications. Meter shall be $\pm 1.5\%$ for the normal flow range when tested in accordance with AWWA Manual M6.

3. Materials: Meter bodies shall be bronze. Casing bolts shall be stainless steel or bronze. All internal hardware shall be stainless steel.
4. End Connections: 5/8-inch through 1-inch meters shall have external straight threads. 1 1/2-inch through 2-inch meters shall have flanged ends.
5. Dimensions: The face to face length of the meter shall be as follows:

Meter Size (inches)	Face-to-Face Dimensions (inches)
5/8	7 1/2
5/8 by 3/4	7 1/2
3/4	9
1	10 3/4
1 1/2	13
2	17

6. Measuring Chamber: Measuring chambers shall be non-hydrolyzing synthetic polymer.
7. Pistons or Disks: Pistons or nutating disks shall be vulcanized rubber or plastic.
8. Strainers: If recommended by the manufacturer, meters shall have plastic or stainless steel strainers. If a strainer is not required, manufacturer must explicitly state this in the warranty certificate.
9. Register and Register Box Connection to Meter Case: Registers and register boxes shall be secured to the main case by acceptable tamper-proof means. Safety wiring of standard bolts and screws is not considered an acceptable method of tamper proofing. Register boxes and covers shall be either bronze or a suitable synthetic material.
10. Warranty: Positive Displacement Meters shall be supplied with the following guarantee:
 - a. Guaranteed new-meter accuracy ($\pm 1.5\%$) for 5 years.
 - b. Measuring chambers and disks or pistons guaranteed for 15 years.
 - c. Registers guaranteed for 25 years.
11. Acceptable Manufacturers: Positive Displacement meters shall be Sensus SR-II, Badger Recordall, or Neptune T-10, no equal.

E. Single-Jet Meters (2-Inch through 6-Inch)

1. General: Meters shall conform to the material and performance requirements of AWWA C712 as applicable and the specifications herein.
2. Certification: The manufacturer shall furnish certified test results for each meter showing that it has been tested for accuracy of registration according to manufacturer specifications. Meter shall be $\pm 1.5\%$ for the normal flow range when tested in accordance with AWWA Manual M6.

3. Materials: Meters shall have a low lead brass body, and a polypropylene impeller. Register boxes and covers shall be either bronze or a suitable synthetic material.
4. End Connections: End connections shall be per IRWD Standard Drawing W-5.
5. Dimensions: The maximum face to face length of the meter shall be as follows:

Meter Size (inches)	Maximum Face-to-Face Dimensions (inches)
2	17
3	24
4	29
6	36 1/2

6. Straightening Vanes: Not required.
7. Calibration Adjusting Vane: Not required.
8. Rotors and Shafts: Rotors shall be thermoplastic or stainless steel with graphite or tungsten carbide bearings rotating on a stainless steel shaft. Motion shall be transmitted from the rotor to the register through a magnetic coupling or directly driven shaft. Worm gears shall not be permitted.
9. Register and Register Box Connection to Meter Case: Registers and register boxes shall be secured to the main case by acceptable tamper-proof means. Safety wiring of standard bolts and screws is not considered an acceptable method of tamper proofing. Register boxes and covers shall be either bronze or a suitable synthetic material.
10. Strainers: Strainers are optional. When strainers are used they shall comply with Part 2, F.10 of this specification.
11. Measuring Chamber and Strainer Cover: Measuring chamber and strainer cover shall be Type 316 stainless steel.
12. Warranty: Single-Jet meters shall be supplied with the following guarantee:
 - a. Guaranteed new-meter accuracy ($\pm 2\%$) for 5 years.
 - b. Measuring chambers and meter body guaranteed for 20 years.
 - c. Registers guaranteed for 5 years (Encoded output registers).
13. Acceptable Manufacturers: Single-Jet meters shall be Metron-Farnier Spectrum or Enduro Series Single-Jets, no equal.
14. Application: Single-Jet meters shall be used where there are low or mixed flow conditions as determined by the District.

F. Turbine Meters (2-Inch through 10-Inch)

1. General: Meters shall conform to the material and performance requirements of AWWA C701 Class II as applicable and the specifications herein.
2. Certification: The manufacturer shall furnish certified test results for each meter showing that it has been tested for accuracy of registration according to manufactures specifications. Meter shall be $\pm 1.5\%$ for the normal flow range when tested in accordance with AWWA Manual M6.
3. Materials: Meters shall have bronze or ductile iron main cases.
4. End Connections: End connections shall be per IRWD Standard Drawing W-5.
5. Dimensions: The maximum face to face length of the meter and strainer shall be as follows:

Meter Size (inches)	Maximum Face-to-Face Dimensions (inches)
2	17
3	24
4	29
6	36 1/2
8	43 3/4
10	60

6. Straightening Vanes: Straightening vanes shall be provided in the main case.
7. Calibration Adjusting Vane: A calibration-adjusting vane located in the measuring chamber shall be provided.
8. Rotors and Shafts: Rotors shall be thermoplastic or stainless steel with graphite or tungsten carbide bearings rotating on a stainless steel shaft. Motion shall be transmitted from the rotor to the register through a magnetic coupling or directly driven shaft. Worm gears shall not be permitted.
9. Register and Register Box Connection to Meter Case: Registers and register boxes shall be secured to the main case by acceptable tamper-proof means. Safety wiring of standard bolts and screws is not considered an acceptable method of tamper proofing. Register boxes and covers shall be either bronze or a suitable synthetic material.
10. Strainers: Meters shall be equipped with strainers. The strainer body and cover shall be bronze, cast iron or ductile iron. Cast iron or ductile iron strainers shall be epoxy lined in accordance with Section 09900, Painting and Coating, System No. G-1. Strainers shall be furnished with stainless steel screens with an effective open area at least double the area of the meter.
11. Measuring Chamber and Strainer Cover: Measuring chamber and strainer cover shall be Type 316 stainless steel or epoxy coated ductile iron.
12. Warranty: Turbine Meters shall be supplied with the following guarantee:

- a. Guaranteed new-meter accuracy ($\pm 1.5\%$) for 5 years.
 - b. Measuring chambers and disks or pistons guaranteed for 15 years.
 - c. Registers guaranteed for 25 years.
13. Acceptable Manufacturer: Turbine Meters shall be Sensus Omni T2, no equal.
 14. Application: Turbine Meters shall be used only in constant high flow conditions as determined by the District.

G. Totalizer - Transmitter

1. General: Totalizer - transmitters shall be furnished with all necessary mounting hardware for operation from the meter.
2. Operation: The transmitter shall have integrally mounted electronic circuitry to convert to both a true 2-wire 4-20 mA DC output linear to flow rate and a true 2-wire scaled pulse.
 - a. The 4-20 mA DC output shall operate from an external regulated 18-30 volt DC power supply with load capacity of 575 ohms at 28 volts DC. The accuracy of the 4-20 mA output shall be better than $\pm 0.5\%$ of scale.
 - b. The pulse output shall operate from an external regulated 10-30 volts DC power supply which can be either the 4-20 mA DC power supply or a separate power supply. The pulse circuit voltage drop across the transmitter shall be 3 volt DC or less. Each pulse shall represent the volume of the least significant totalizer digit.

H. Manual Valves

Valves shall be per IRWD Standard Drawings and conform with Section 15100, Manual Valves. Valves on by-pass shall be lockable in the closed position.

PART 3 - EXECUTION

A. Meter Installations

1. Residential Meters: Residential meters shall be installed as shown on the plans, or per IRWD Standard Drawings W-1 and W-2.
2. 3-inch and Larger Meters: 3-inch and larger meters shall be installed as shown on the plans or per IRWD Standard Drawing W-5.

B. Service Piping

All piping for service lines and by-pass lines shall be installed in conformance with Section 15057, Copper Pipe and Fittings, and Section 15051, Installation of Pressure Pipelines.

C. Test Tap

On services 3-inch and larger, a 2-inch service saddle and corporation stop shall be installed on the spool downstream of the meter. The tap shall be located a minimum of two pipe diameters downstream of the meter. In lieu of a test tap, a tee with a tapped blind flange may be installed immediately downstream of the meter.

D. Painting and Coating

Exposed and buried piping, and meter lids on all potable and recycled water services shall be painted or coated in accordance with Section 09900, Painting and Coating.

E. Testing

Meter services shall be hydrostatically pressure tested during the testing of pipeline in accordance with Section 15042, Hydrostatic Testing of Pressure Pipelines. Meters 3-inch and larger will be tested by the District to verify accuracy prior to being placed into service.

END OF SECTION

SECTION 15151: FACILITIES IDENTIFICATION

PART 1 - GENERAL

A. Description

This section describes materials and installation of sewer, potable and recycled water facilities identification for pipe, valves, valve boxes, and other pipeline appurtenances.

B. Related Work Specified Elsewhere

1. Painting and Coating: 09900
2. Manual Valves: 15100
3. Cathodic Protection and Joint Bonding: 16640

C. Submittals

1. Shop drawings shall be submitted in accordance with the General Provisions and as specified herein.
2. Submit material samples of ID and locator tape.
3. Submit drawings showing location and size of labels and signs.

PART 2 - MATERIALS

A. Buried Piping ID Tape, Locator Tape, and Tracer Wire

1. ID Tape: Identification tape shall be an inert plastic film specifically formulated for prolonged underground use. The minimum thickness shall be 4 mils and the overall width of the tape and lettering size shall be in accordance with the following table.

Pipe Size (inches)	ID Tape Width (inches)	Locator Tape Width (inches)	Min. Lettering Size (inches)
2 and less	2	3	1 1/2
Less than 8 and greater than 2	6	3	2
8 and larger	12	3	2

- a. Potable Water Pipelines: Blue ID tape with black lettering identifying the potable waterline, shall be used on all pipelines 1-inch and larger. For copper services, ID tape shall be placed over the top of the pipe and shall be taped to the copper pipe at 2 foot intervals. The ID tape shall extend up into the air-vacuum release assembly or other appurtenances a minimum of 12-inches, so that it can be read clearly by opening the box or enclosure. ID tape wording shall read: "CAUTION: DOMESTIC WATERLINE BURIED BELOW".

- b. Recycled Water Pipelines: Purple ID tape with black lettering identifying the recycled waterline, shall be used on all pipelines 1-inch and larger. For copper services, ID tape shall be placed over the top of the pipe and shall be taped to the copper pipe at 2 foot intervals. The ID tape shall extend up into the air-vacuum release assembly or other appurtenances a minimum of 12-inches, so that it can be read clearly by opening the box or enclosure. ID tape wording shall read: "CAUTION: RECYCLED WATERLINE BURIED BELOW".
- c. Sewer Pipelines: Green ID tape with black lettering identifying the sewer line, shall be used on all pipelines 1-inch and larger. The ID tape wording shall read: "CAUTION: SEWER LINE BURIED BELOW".
- d. Untreated Water Pipelines: White ID tape with black lettering identifying the untreated waterline, shall be used on all pipelines 1-inch and larger. The ID tape wording shall read: "CAUTION: UNTREATED WATERLINE BURIED BELOW".
- e. Cathodic Protection Wiring: Red ID tape with black lettering shall be used for cathodic protection wiring. The ID tape shall be 3-inch wide. The tape shall have a minimum tensile strength of 60 pounds per 3-inch strip. The ink used to print the lettering on the tape shall be permanent and not be removable by normal handling or upon prolonged underground burial. Lettering shall be a minimum of 2-inch high letters with the wording: "CAUTION CATHODIC PROTECTION CABLE BURIED BELOW".
- f. Other Pipelines:
 - i. Identification of all exposed pipe shall be accomplished by color-coding with bands and by process descriptions. Color band stickers shall be adhered directly upon the pipe.
 - ii. Each pipe identification shall identify the name of the process liquid in the pipe and the direction of flow. All labels shall be preprinted on pressure-sensitive adhesive-backed vinyl cloth or plastic tape. Arrows shall be die-cut of the same type of material as the labels.
 - iii. Letter sizes and colors for lettering, arrows, and background shall conform to ANSI A13.1.
 - iv. Preprinted identification devices shall be manufactured by Brady or Seton.
 - v. Existing Identification Systems: In installations where existing piping identification systems have been established, the Contractor shall continue to use the existing system. Where existing identification systems are incomplete, the Contractor shall utilize the existing system as far as practical and supplement with the specified system. The objective is to fully identify all new piping, valves, and appurtenances to the level specified herein.

2. Locator Tape: Locator tape shall have a minimum thickness of 6 mils. Locator tape shall be installed over non-metallic pipe, shall be similar to ID tape, and shall include a metallic substance that can be registered by a magnetic field location device. ID tape and locator tape shall be as supplied by Christy's, Griffolyn Co., Inc., Hytech, Terra Tape, Division of Reef Industries.
3. Tracer Wire: Where shown on the plans, tracer wire shall be installed instead of locator tape on non-metallic pressurized pipes sizes 6-inches and greater. Tracer wire shall be installed in accordance with the IRWD Standard Drawings. The tracer wire shall consist of a #8 AWG Type UF (direct burial) stranded single conductor cable with high density polyethylene (HDPE) or high molecular weight polyethylene (HMWPE) insulation. The insulation shall be black in color. The tracer wire shall be taped to top of pipe every ten feet.

B. Warning Encasement for Underground Recycled Metallic Water Pipelines

Unless otherwise specified, pipe and fittings shall be polyethylene encased in accordance with AWWA/ANSI C105/A-21.5 and shall be "purple" in color and shall bear the water identification markings called for in Section D, Labels and Tags, sub-paragraph 2, Recycled Water Identification.

C. Purple PVC Pipe for Recycled Water Pipelines

1. General: PVC pipe used for recycled water use shall conform to the requirements of Section 15064, PVC Pressure Distribution Pipe and Fittings, and shall be colored purple.
2. PVC Pipe Coloring and Markings: PVC pipe shall be purple, and shall be marked on both sides of the pipe with the wording: "CAUTION: RECYCLED WATER - DO NOT DRINK." Lettering shall be a minimum of 1/2-inch high black letters, and shall be repeated every 12-inches. The purple pipe color shall be achieved by adding pigment to the PVC material as the pipe is being manufactured.

D. Labels and Tags

Labels shall be inert plastic film specifically formulated for prolonged exposure. The minimum thickness shall be 4 mils for adhesive backed labels and 10 mils for tag type labels. Tag type labels shall have reinforced tie holes and shall be attached with heavy-duty nylon fasteners. The size, type of label and location shall be dictated by each individual application and subject to acceptance by the District Representative.

1. Potable Water Identification: Labels shall be prepared on a blue field, and shall have the words: "POTABLE WATER" printed on the field in black letters, as directed by the District Representative. Minimum letter height shall be 1/2-inch.
2. Recycled Water Identification: Labels shall be prepared on a purple field, and shall have the words: "CAUTION: RECYCLED WATER - DO NOT DRINK" printed on the field in black letters, as directed by the District Representative. Minimum letter height shall be 1/2-inch.
3. Identification Tags: The water service meter identification tag shall identify the address or unit number served by the meter. The identification tag shall be rotary engraved with identifying letters and numbers. The circular plastic tag shall be 1/16-inch thick, 2-inch diameter, and the exterior shall be UV resistant 3 ply (color on both sides) lamicoic plastic by Rowmark, or Gravoply. Color shall be

Blue with a white core for potable, Purple with a white core for recycled, Light-Blue with white core for untreated, or Green with white core for sewer. IRWD shall provide the un-engraved plastic tags to the Contractor for engraving. The Contractor shall engrave the address and/or unit number into the plastic tag.

4. Other Tagging: When Process and Instrumentation Diagrams (P&ID's) are included in the drawings, tags shall be provided for all items including, but not limited to, valves, instruments, and equipment shown on the P&ID's. Tagging conventions shall be as shown on the drawings, unless otherwise specified by the District. The identification tag shall be rotary engraved with white identifying letters and numbers. The circular plastic tag shall be 1/16-inch thick, 2-inch diameter, and the exterior shall be UV resistant 3 ply (color on both sides) lamicoic plastic by Rowmark, or Gravoply. Tag color shall be black with white core. Contractor shall provide plastic tags with engraving.

PART 3 - EXECUTION

A. Installation of Pipe ID Tape, Locator Tape and Tracer Wire

1. ID Tape: ID tape shall be installed directly on the top of the pipe longitudinally and shall be centered. The ID tape shall be installed continuously for the entire length of the pipe and shall be fastened to each pipe length by plastic adhesive tape banded around the pipe and ID tape at no more than 2-foot intervals. Taping attached to the sections of pipe before laying in the trench shall have 5-foot minimum overlap for continuous coverage. All risers between the main line and control valves shall be installed with ID tape.
2. Locator Tape: Locator tape shall be installed directly on top of the pipe zone backfill layer, and shall be centered over non-metallic pipelines.
3. Tracer Wire: Tracer wire shall be installed on top of the pipe and over the ID tape. Wire shall be continuous strand. Crimpable copper butt splice kits are permitted in valve cans only. For main line valve cans, wire shall be routed up the outside of the valve riser, into the valve can at the top, 12-inch looped, and back down the outside of the valve riser.
 - a. Tracer Wire Continuity Tests: The Contractor shall notify the District Representative that the tracer wire is ready for testing. The Contractor shall retain a third party specialist to facilitate a continuity test on the tracer wire. The Contractor shall submit a certified report by the third party testing service stating that the tracer wire is performing satisfactorily. All tests made must be reviewed and approved by the District before the work is accepted. The District reserves the right to spot check any or all tests performed. All construction defects must be repaired and retested before the final acceptance is made. All unacceptable tests must be re-performed by the Contractor at no cost to the District.

B. Installation of Labels and Signs

1. Method of Attachment: Labels shall be firmly attached using heavy-duty nylon fasteners, and shall be sized and installed at locations as shown on the plans.

2. Equipment Requiring Labels or Tags: Labels shall be installed on all appurtenances in vaults, such as, but not limited to, air release valves, blowoffs, and meters, and on designated facilities, such as, but not limited to, controller panels and washdown or blowoff hydrants for water trucks and temporary construction services. Pumps and pipe shall be identified with a painted label. Within a fenced area, at least one sign shall be posted on the fence which can be readily seen.
3. Painted Labels: Painted labels may, at the District Representative's discretion, be acceptable in lieu of plastic labels.

C. Installation of Water Identification Tags

Identification tags shall be securely attached to water meters using UV rated zip ties rated to hold 50 pounds.

END OF SECTION

SECTION 15162: FLEXIBLE PIPE COUPLINGS AND EXPANSION JOINTS

PART 1 - GENERAL

A. Description

This section describes materials and installation of flexible gasket sleeve-type compression pipe couplings for steel, asbestos cement pipe and ductile iron pipe.

B. Related Work Specified Elsewhere

1. Painting and Coating: 09900
2. Hydrostatic Testing of Pressure Pipelines: 15042
3. Cathodic Protection and Joint Bonding: 16640

C. Submittals

1. Shop drawings shall be submitted in accordance with the General Provisions and as specified herein.
2. Submit manufacturer's catalog data on flexible pipe couplings. Show manufacturer's model or figure number for each type of coupling or joint for each type of pipe material for which couplings are used.
3. Submit manufacturer's recommended torques to which the coupling bolts shall be tightened for the flexible gasket sleeve-type compression pipe couplings.
4. Show materials of construction by ASTM reference and grade. Show dimensions.
5. Show number, size, and material of construction of the rods and lugs for each thrust harness.

PART 2 - MATERIALS

A. Flexible Pipe Couplings for Steel Pipe

1. General: Steel couplings shall have center sleeves made of steel conforming to ASTM A36, A53 (Type E or S), or A512 having a minimum yield strength of 30,000 psi. Follower rings shall be malleable iron (ASTM A47, Grade 32510), ductile iron (ASTM A536), or steel (ASTM A108, Grade 1018, or ASTM A510, Grades 1018 or 1021). Follower ring material shall match that of the pipe being joined. For example, steel follower rings shall be used on steel pipe and malleable iron rings shall be used on ductile iron pipe. Minimum center sleeve lengths shall be per the table below.

Minimum Center Sleeve Length (inches)	Pipe Sizes (inches)
5	1-3
7	4
10	6-24
Submit for Approval	Larger than 24

2. Sleeve Bolts: Sleeve bolts shall have a minimum yield strength of 40,000 psi, an ultimate strength of 60,000 psi, and shall be fabricated of Type 316 stainless steel conforming to ASTM A193 (Grade B8M) for bolts and ASTM A194 (Grade B8M) for nuts, and shall conform to AWWA C111.
3. Manufacturers: Flexible pipe couplings for steel pipe shall be steel, and shall be Baker Series 200, Dresser, Ford, Romac, or Smith-Blair Type 411.

B. Joint Harness

1. Tie Bolts or Studs: Tie bolts or studs shall be as shown in AWWA Manual M11, Table 7-3, 7-4, and 7-6. The minimum numbers and sizes of tie bolts or studs shall be as shown in the table below. Bolt or stud material shall conform to ASTM B193, Grade B8. Nuts shall conform to ASTM A194, Grade B8M. Lug material shall conform to ASTM A36, ASTM A283, Grade B, C, or D, or ASTM A285, Grade C. Lug dimensions, plate thickness, number of bolts, and weld dimensions shall be as shown in AWWA Manual M11, Figure 7-25.

Tie Bolts or Stud Requirements for Flexible Pipe Couplings				
	150 psi		250 psi	
Nominal Pipe Size (inches)	No. of Bolts or Studs	Size (inches)	No. of Bolts or Studs	Size (inches)
2	2	5/8	2	5/8
3	2	5/8	2	5/8
4	2	5/8	2	5/8
6	2	5/8	2	5/8
8	2	5/8	2	5/8
10	2	5/8	2	3/4
12	2	3/4	2	7/8
14	2	3/4	2	1
16	2	7/8	2	1 1/8
18	2	1	2	1 1/4
20	2	1	2	1 1/4
24	4	7/8	4	1 1/8
30	4	1 1/8	4	1 3/8
36	4	1 1/4	4	1 5/8
42	4	1 1/2	6	1 1/2
48	6	1 5/8	6	1 3/4
54	6	1 1/2	8	1 3/4
60	6	1 5/8	10	1 5/8
66	8	1 5/8	12	1 3/4
72	8	1 3/4	12	1 7/8
84	10	1 3/4	14	2
96	12	1 7/8	16	2 1/4

2. Criteria for Number and Size of Tie Bolts or Studs: The number and size of bolts shall be selected based on the test pressure shown in Section 15042, Hydrostatic Testing of Pressure Pipelines. For test pressures less than 150 psi, the 150 psi design in the table above shall be used. For test pressures between 150 and 250 psi, the 250 psi design in the table above shall be used.
3. Washers: Stainless steel, type 316 washers shall be provided for each lug. Washer material shall be the same as the nuts. Minimum washer thickness shall be 1/8-inch.
4. Wall Thickness Requirement for Welded Lugs: Pipe wall to which lugs are welded shall be adequate to resist stresses. If necessary, the pipe wall thickness shall be increased.

C. Flexible Pipe Couplings for Asbestos-Cement Pipe

1. General: Flexible pipe couplings for asbestos-cement pipe shall be ductile iron, with long-style center sleeves a minimum of 7-inches in length and shall have corrosion resistant Type 316 stainless steel nuts, bolts and washers. Center sleeve and follower rings shall be epoxy coated and holiday free.

2. Sleeve Bolts: Sleeve bolts shall be corrosion resistant type 316 stainless steel with a minimum yield strength of 45,000 psi and shall conform to ASTM A193 and AWWA C111.
3. Manufacturers: Flexible pipe couplings for asbestos-cement pipe shall be Baker Series 228, Dresser Style 40, Ford Style FRR, Romac Style 501, or Smith-Blair Type 442.

D. Flexible Couplings for Ductile Iron Pipe

1. General: Ductile iron pipe couplings shall have center sleeves of ASTM A126 Class B ductile iron with a minimum yield strength of 30,000 psi. Follower rings shall be malleable iron ASTM A47 Grade 32510 or ductile iron ASTM A536. Minimum center sleeve length shall be 7-inches for pipe sizes up to 6-inches and shall be a minimum of 12-inches for larger pipe diameters.
2. Sleeve Bolts: Sleeve bolts shall be corrosion resistant type 316 stainless steel with a minimum yield strength of 45,000 psi and shall conform to ASTM A193 and AWWA C111.
3. Manufacturers: Flexible couplings for ductile iron pipe shall be ductile iron: Baker Series 228, Dresser Style 153, Ford Style FC1, Romac Style 501, or Smith-Blair Type 442.

E. Transition Couplings

1. Steel Pipe and Concrete Cylinder Pipe: Transition couplings for connecting steel pipe and concrete cylinder pipe having different outside diameters shall be steel: Baker Series 212 or 240, Dresser Style 62 or 162, or Smith-Blair Type 413.
2. Ductile Iron Pipe, PVC Pipe, and Asbestos Cement Pipe: Transition couplings for connecting ductile iron pipe, PVC pipe, and asbestos cement pipe having different outside diameters shall be ductile iron, and shall be Baker Series 236, Dresser, Ford Style FC2A, Smith-Blair Type 441, or Romac.
3. Sleeve Bolts: Sleeve bolts shall have a minimum yield strength of 40,000 psi, an ultimate strength of 60,000 psi, shall be Type 316 stainless steel conforming to ASTM A193 (Grade B8M) for bolts and ASTM A194 (Grade B8M) for nuts, and shall conform to AWWA C111.

F. Wide Range Couplings

1. General: Couplings shall have ductile iron sleeves and follower flanges in conformance with ASTM A536. Gaskets shall be Buna-N.
2. Sleeve Bolts: Sleeve bolts shall be corrosion resistant type 316 stainless steel with a minimum yield strength of 45,000 psi and shall conform to ASTM A193 and AWWA C111.
3. Manufacturers: Wide range couplings shall be Ford Style FC2W, Romac Style XR501 or HP Extended Range, or Smith-Blair Quantum.

G. Flanged Coupling Adapters

Flanged coupling adapters may be used, where detailed on the approved plans, to install valves, meters, and other types of flanged fittings to plain end pipe of diameter 10-inches and smaller. Flanged coupling adapters shall be Baker Series 601 or 604, Dresser Style 127, Ford Style FFCA, or Smith-Blair Type 913 or 914.

H. Expansion Joints

1. General: Expansion joints shall have body, flanges, and slip pipe of carbon steel. Packing shall consist of a minimum of four rubber rings, each separated by jute packing. For installation on steel pipelines, expansion joint shall have plain ends and be beveled for welding. For installation in ductile iron pipelines, expansion joint shall have plain ends. Slip pipe shall have a machined surface, and body shall be equipped with pipe stops. Where called for on the plans, limit or stop rings and limit rods shall be provided to prevent the slip pipe from pulling out of the joint.
2. Limit Rods and Body Studs, Bolts and Nuts: Limit rods and body studs, bolts, and nuts shall be Type 316 stainless steel conforming to ASTM A193 (Grade B8M) for rods and bolts, and ASTM A194 (Grade B8M) for nuts.
3. Manufacturers: Expansion joints shall be Baker Series 403 or 404 or Smith-Blair Type 611 or 612.

I. Sleeve Bolts and Nuts for Flanges

1. Stainless Steel Bolts: Bolts and nuts for buried and submerged flanges, flanges in underground vaults and structures, and flanges located outdoors above ground shall be Type 316 stainless steel conforming to ASTM A193 (Grade B8M) for bolts and ASTM A194 (Grade B8M) for nuts.
2. Washers: Type 316 stainless steel washers shall be provided for each nut. Washers shall be of the same material as the nuts.

PART 3 - EXECUTION

A. Installation of Flexible Pipe Couplings and Expansion Joints

1. General: Oil, scale, rust, and dirt shall be cleaned from pipe ends. Gaskets in flexible pipe couplings shall be cleaned before installing. Expansion joints shall be installed per manufacturer's recommendations. Expansion joints shall be installed so that 50% of total travel is available for expansion and 50% is available for contraction.
2. Bolt Thread Lubrication: Bolt threads shall be lubricated with anti-seize compound prior to installation.

B. Painting and Coating

1. Couplings: Flexible and wide range pipe couplings (including joint harness assemblies), transition couplings, flanged coupling adapters, and expansion joints shall be coated per Section 09900, Painting and Coating; sleeves shall be coated

per System G-1. After installation, couplings shall be wrapped with 8-mil polyethylene wrap per AWWA C105.

2. Interior Surface Coating: Interior surfaces of flexible couplings, wide range couplings, transition coupling sleeves, and the body of expansion joints shall be coated per Section 09900, Painting and Coating, System G-1.

C. Bonding Flexible Pipe Couplings

Buried flexible pipe couplings that are connected to ductile-iron, cast-iron, or steel pipe shall be bonded to adjacent piping as described in Section 16640, Cathodic Protection and Joint Bonding.

D. Hydrostatic Testing

Flexible pipe couplings and expansion joints shall be hydrostatically tested in place with the pipe being tested. Test shall be performed in accordance with Section 15042, Hydrostatic Testing of Pressure Pipelines.

END OF SECTION

SECTION 16010: GENERAL ELECTRICAL REQUIREMENTS

PART 1 - GENERAL

A. Description

This section includes materials, installation, and testing of the electrical system.

B. Related Work Specified Elsewhere

1. The Contract Documents are complementary; what is called for by one is as binding as if called for by all.
2. It is the Contractor's responsibility for scheduling and coordinating the Work of subcontractors, suppliers, and other individuals or entities performing or furnishing any of the Contractor's work.
3. The following sections are related to the Work described in this Section. The list of Related Sections is provided for convenience only and is not intended to excuse or otherwise diminish the duty of the Contractor to see that the completed Work complies accurately with the Contact Documents.
 - a. Testing, Training, and Facility Start-up: 01510
 - b. Cabinets and Enclosures: 16135
 - c. Electrical Testing: 16950
 - d. Instrumentation and Control System Testing and Start-Up: 17332

C. Submittals

1. Shop drawings shall be submitted in accordance with the General Provisions and as specified herein.
2. Complete fabrication, assembly, and installation drawings, wiring and schematic diagrams; and details, specifications, and data covering the materials used and the parts, devices, and accessories forming a part of the equipment furnished.
3. Instrument tag numbers indicated on the contract drawings shall be referenced where applicable.
4. Submittal data for multifunctional instruments shall include complete descriptions of the intended functions and configurations of the instruments.
5. Product catalog cut sheets clearly marked to show the model number, optional features, and intended service of the device.
6. A detailed list of any exceptions, functional differences, or discrepancies between the supplier's proposed system and the contract requirements.
7. Complete panel fabrication drawings and details of panel interior layout, wiring, and panel coating. Panel and subpanel drawings shall include overall dimensions,

metal thickness, door swing, mounting details, and front of panel arrangement to show general appearance, with spacing and mounting height of instruments and control devices.

8. System wiring and installation drawings for all interconnection wiring between components of the systems furnished and for all interconnecting wiring between the related equipment and the equipment furnished under this section. Wiring diagrams shall show complete circuits and indicate all connections.
9. If panel terminal designations, device interconnections, device features and options, or other features are modified as a result of the fabrication process or factory testing, updated drawings reflecting the modifications shall be submitted.
10. The coordination and arc flash study shall be completed using the ETap program. Once the study is completed and the District's comments are incorporated, the contractor shall as-built the changes and submit the final copy in ETap format with all required supporting files to the District. The electronic ETap copy shall be compatible for ETap version 16.1.
11. The coordination study shall be in PDF format with bookmarks for each section. The study shall be provided in accordance with the submittal section. Final selection of all protective device settings or sizes shall be subject to review and acceptance by the District Representative.
12. Operation and Maintenance Manuals shall be submitted in accordance with the General Provisions.

D. Regulatory Agencies and Standards

1. Regulatory Agencies: Installations, materials, equipment, and workmanship shall conform to the applicable provisions of the following agencies and standards:
 - a. National Electrical Code (NEC), Latest Edition.
 - b. State Department of Industrial Safety (CAL/OSHA).
 - c. Local authorities having lawful jurisdiction pertaining to the work required.
2. Underwriters Laboratories, Inc. (UL): Materials, appliances, equipment, and devices shall conform to the applicable UL standards. The label of, or listing by, UL is required wherever applicable on new equipment and a UL recertification on existing equipment.
3. Standards: Where referenced in these specifications or on the drawings, the publications and standards of the following organizations apply:
 - a. American Society of Testing and Materials (ASTM)
 - b. National Electrical Manufacturers Association (NEMA)
 - c. National Fire Protection Association (NFPA)
 - d. American National Standards Institute (ANSI)

- e. Institute of Electrical and Electronic Engineers (IEEE)
- f. Insulated Power Cable Engineers Association (IPCEA)

E. Industry Regulations and Laws

In case of differences between the building codes, specifications, State law, local ordinances, industry standards, utility company regulations, fire insurance carrier's requirements, and the contract documents, the most stringent shall govern. The Contractor shall promptly notify the District in writing of such differences.

F. Utility Company Requirements and Fees

1. The District will make application for electric and communication service. The District will pay utility company fees, cable charges, and added facilities charges.
2. The Contractor shall make any service and installation agreements that the utility companies may require.
3. The Contractor shall obtain utility company approval of service entrance and metering equipment shop drawings prior to starting fabrication. Install electric service entrance equipment in accordance with the serving utility's requirements. Coordinate with the servicing utility to ensure timely connection by the utility.
4. Verify utility companies service point of connection prior to beginning installation.

G. Equipment Enclosures

1. Enclosures for heat sensitive equipment such as VFDs, soft-starters, PLCs, and workstations inside NEMA 4 or NEMA 4X enclosures shall have air conditioning units, unless the equipment is housed in an air-conditioned room/building.
2. Equipment enclosures shall be in accordance with Section 16135, Cabinets and Enclosures.

H. Coordination and Arc Flash Study (CAFS)

1. Provide a complete arc flash hazard study to protect individuals from electrical arc flash injuries. These individuals may include, but not be limited to, individuals who inspect, maintain, or operate energized electrical equipment. The study shall include all equipment at 480 volts and above and all panelboards at 240 volts. The study shall be based on approved equipment as well as existing field equipment, conductor lengths and sizes.
2. Provide arc flash hazard warning labels consistent with the findings of the CAFS. The warning labels are intended to assist individuals with the selection of proper personal protective equipment when working around energized equipment.

3. The arc flash study shall include new and existing equipment. For existing equipment, the Contractor shall be responsible for all onsite data collection and investigation to identify loads and power distribution equipment data.

PART 2 - MATERIALS

A. General

1. Similar materials, instruments and equipment shall be the product of a single manufacturer. The Contractor shall coordinate all instruments and equipment including vendor package systems with the entire project.
2. Provide only products which are new, undamaged, and in the original cartons or containers.
3. Materials and equipment shall be the standard products of manufacturers regularly engaged in the production of such material and shall be the manufacturer's current design.
4. Materials and equipment shall be suitable for storage, installation, and operation in an ambient temperature environment of 0° C to 50° C except where more stringent conditions are stated in individual equipment specifications.
5. Electrical equipment and panels, where called for in a material other than stainless steel, shall be factory finished with manufacturer's standard primer and enamel topcoats, unless stated otherwise in the individual equipment specifications.

B. Operation and Maintenance Manuals

1. The organization of the submittals as required by these Contract Documents shall be compatible to eventually include as one volume of the operation, maintenance, and repair manuals.
2. The complete operation and maintenance manual shall contain all the information included in the submittals, programming instructions, and the additional information required herein. The Contractor shall include all updates resulting from submittal review comments, RFIs and change orders throughout the project.
3. The operation and maintenance manuals shall contain:
 - a. Calibration and maintenance instructions;
 - b. Trouble-shooting instructions; and
 - c. Instructions for ordering replacement parts.

C. As-Built Drawings

1. As-built drawings shall be submitted at the completion of work, and shall depict the final configuration of all installed equipment.
2. All shop drawings shall be updated by the originator to "As-Built" status.

3. "As-Built" drawings shall be provided to the District in both hardcopy and digital formats. Digital files shall be AutoCAD, latest version.
4. All drawings shall become property of the District.
5. The Contractor shall clearly indicate on "As-Built" plans the following information:
 - a. All conduit runs exactly as installed, modified, or abandoned.
 - b. Location of all underground conduits with dimensions.
 - c. Forming, cabling, and identification of all power and control circuits within pull boxes, and terminal boxes.
 - d. All changes and/or deviations in locations, routing, or dimensions or additions to any part of the Electrical work.
 - e. Interior views of each pull box identifying each conduit entrance by conduit number.
 - f. Complete and accurate wiring, schematic, and interconnecting wiring diagrams for all equipment supplied and all work performed.
 - g. Include all updates resulting from submittal review comments, RFIs and change orders throughout the project.

D. Arc Flash Warning Labels

1. Install arc flash warning labels (orange <math><40\text{ cal/cm}^2</math>) or danger labels (red > 40 cal/cm²) in accordance with ANSI Z535.4-2011 (R2017). The labels must be readable in both indoor and outdoor environments and contain the following information. A sample warning label is provided at the end of this Section.
 - a. Arc hazard boundary (inches)
 - b. Working distance (inches)
 - c. Arc flash incident energy at the working distance (calories/cm²)
 - d. PPE category and description including the glove rating
 - e. Voltage rating of the equipment
 - f. Limited approach distance (inches)
 - g. Restricted approach distance (inches)
 - h. Prohibited approach distance (inches)
 - i. Equipment/bus name
 - j. Date prepared

- k. Arc flash hazard study preparer name and address.
- l. Utility power source and alternate power source, if any.

PART 3 - EXECUTION

A. Installation

1. The drawings indicate connections for typical equipment only. If the equipment furnished is different from what is shown, provide the modifications necessary for a safe and properly operating installation in accordance with the equipment manufacturer's recommendations.
2. The drawings indicate diagrammatically the desired location and arrangement of outlets, conduit runs, equipment, and other items. Field determine exact location based on physical size and arrangement of equipment, finished elevations, and obstructions.
3. Work or equipment not indicated or specified, which is necessary for the complete and proper operation of the electrical systems, shall be accomplished without additional cost to the District.

B. Foreign Power Isolation in Equipment Enclosures

1. Provide foreign power circuit isolation devices in equipment enclosures. PLC input/output circuits for example, are a source of foreign power when they exist in an equipment enclosure such as a local control panel which has a separate source of control power. Circuits which are a source of foreign power shall pass through an isolation device where the wiring enters the equipment enclosure. Isolation devices are required in control cabinets, MCC buckets, and the like, to provide an easily accessible isolation point, whenever the power source for the circuit would be considered foreign power in the enclosure. Isolation devices shall be clearly labeled.
2. Equipment manufacturers shall supply isolation devices integral with their equipment whenever possible (isolation switches integral with disconnect handles on MCC buckets for example).
3. Devices shall allow for the operation of equipment with doors open to allow for testing and/or maintenance.
4. The Contractor shall be responsible for supplying isolation devices as needed such that the complete system of power distribution installed at the facility complies with this specification.

C. Identifications and Signs

1. Mark each individual panelboard, motor controller, power panel, transformer, circuit breaker, disconnect switch, local control panel (LCP), vendor control panel (VCP), HVAC equipment, switchboard, timer, relay, and contactor to identify each item with its respective service or function and unique identification number as shown on the drawings. Each label shall contain the unique identification

number for the equipment and identification of the source of power to the equipment.

2. Provide polycarbonate nameplates with engraved lettering not less than 1/4-inch high. Use black-on-white laminated polycarbonate plastic, attached with sheet metal screws or self-adhesive backs. Nameplates shall be rotary engraved with white letters and numbers.

D. Performance Tests

1. After the electrical installation is complete, test it to demonstrate that the entire system is in proper working order and in accordance with the drawings and specifications.
2. Perform electrical testing per Section 16950, Electrical Testing. The testing shall demonstrate the proper installation and integrity of the electrical power distribution, electrical protection, and major equipment (MCC, transformers, motors, power monitoring equipment, and similar type equipment).
3. Perform equipment startup and performance testing per Section 01510, Testing, Training and Facility Start-Up and Section 17332, Instrumentation and Control System Testing and Start-Up. The tests specified in Sections 01510 and 17332 involve equipment performance tests and integrated testing of systems.

E. Coordination and Arc Flash Study

1. The Contractor shall provide a complete coordination study of relays, fuses, circuit breakers, and all other protective devices.
2. The coordination study shall include the entire distribution system starting with the smallest 480 volt, 3 phase, 60 Hz circuit protective device on the load end, to the nearest protective device on the power company's line side, or for work in the District's existing facilities, to the nearest protective device on the District's distribution system.
3. The study shall include, but not be limited to, the following:
 - a. A tabulation of all protective relay and circuit breaker trip settings and recommended fuse sizes and types.
 - b. Motor starting profiles for all 480V motors.
 - c. Starter in-rush current shall be provided for all motor starting types such as FVNR, reduced voltage soft-starter or VFD.
 - d. Transformer damage curves and protection evaluated in accordance with ANSI/IEEE C57.109.
 - e. The Contractor shall obtain utility company information such as available short circuit amperes, utility transformer rating and impedance, utility cable lengths, material and size, and coordination curves, if available.

4. The Contractor shall be responsible for obtaining all of the required relay, fuse, and circuit breaker coordination curves; transformer damage curves; motor data; and pertinent information, for all new and existing electrical equipment.
5. The Contractor shall be responsible for coordinating with the Utility Company to obtain the required protective device curves.
6. The Contractor shall be responsible for all field work required to obtain necessary data on existing relays, circuit breakers, fuses, and transformers to be included in the coordination study.
7. The Contractor shall incorporate all District comments and update the coordination study.
8. Coordination study shall reduce the available arc flash to the maximum extent possible while maintaining proper coordination.
9. The Reduced Energy Maintenance Switch (REMS) settings shall be defined and included in the coordination study.
10. The coordination study shall provide a full study for all power sources. Provide a short circuit and arc flash study for Utility power and for generator power when a permanent generator is available.
11. Provide a short circuit availability and arc flash table showing each circuit breaker rating when on Utility power and on generator.

F. Arc Flash Hazard Study

1. The arc flash hazard study shall utilize the coordination study as the basis for equipment information.
2. The Contractor shall adhere to the requirements of the latest version of NFPA 70E.
3. The Contractor shall provide labels for each 480 equipment, LCP, VCP, disconnect, PLC cabinet, 240V panel, and control cabinet as required by the District.
4. The labels shall be UV resistant, rated for outdoor use and shall strongly adhere to metal enclosures. Outdoor switchgear, switchboards, motor control centers, panelboards, and control cabinets shall have an arc flash label on the exterior and interior doors.
5. Personnel performing the arc flash analysis shall be trained and experienced in accordance with NETA training specifications concerning the apparatus and systems being evaluated.
6. Sample Arch Flash Warning Label:



DANGER

Arc Flash and Shock Risks Appropriate PPE Required

ARC FLASH RISK PROTECTION Incident Energy: 73.6 cal/cm ² Arc Flash Boundary: 198 in Working Distance: 18 in Shock Protection Boundaries: Glove Class: 00 Shock Hazard W/O Covers: 480 VAC Limited Approach: 42 in Restricted Approach: 12 in Fault Current (kA): 15.60 Upstream PD: MaxTripTime @2.0s	PPE: (NFPA 70E - 130.5(G)) No Safe PPE Available
Equipment ID: MSB UTILITY	09/22/2023

END OF SECTION

SECTION 16051: MISCELLANEOUS ELECTRICAL DEVICES

PART 1 - GENERAL

A. Description

This section describes materials and installation of miscellaneous electrical devices and equipment including disconnect switches, push buttons, thermostats, control relays, terminal blocks, intrusion switches, pilot lights, and equipment for PLC, vendor, and local control panels.

B. Related Work Specified Elsewhere

1. General Electrical Requirements: 16010
2. General Instrumentation Control Requirements: 17000

C. Submittals

1. Shop drawings shall be submitted in accordance with the General Provisions and as specified herein.
2. Submit ratings and characteristics including voltage ratings, continuous current ratings, conduit entry restrictions, and enclosure type and dimensions.

PART 2 - MATERIALS

A. Disconnect Switches

1. Provide non-fusible or fusible disconnect switches with ampere rating and number of poles as indicated on the drawings. Switches for use on circuits 480-volt and below shall be NEMA heavy-duty Type HD. Mechanisms shall have quick-make and quick-break operating handles and provisions for padlocking in the "OFF" position. The switch shall have an interlock to prevent unauthorized opening of the hinged cover when the switch is in the "ON" position and an interlock to prevent closing the switch mechanism with the hinged cover open. Fusible switches shall be equipped with rejection feature. On the front of the enclosure, attach a nameplate that identifies the load per Section 16010.
 - a. Indoor Dry Locations: NEMA Type 4/12
 - b. Outdoor/Indoor Wet Locations: NEMA Type 4X 316 Stainless Steel
2. Where approved by the District, provide motor rated toggle switches for motor loads less than 3/4 HP at 120V. Motor rated toggle switches shall be heavy-duty industrial grade with rugged thermoplastic top and bottom housing.

B. Pushbuttons

1. Pushbuttons shall be NEMA rated heavy duty, oil-tight type with synthetic rubber boots and any special gasketing required to make the completed station watertight. Provide NEMA Type 4X watertight, corrosion-resistant enclosures constructed of stainless steel or glass polyester.
2. Install provisions for locking pushbuttons in the OFF position wherever lockout provisions are indicated. Provide Allen-Bradley Bulletin 800H, no equal.

C. Emergency Stop Pushbuttons

1. Emergency stop pushbuttons shall be non-illuminated, mushroom head, push-pull/twist type with red color cap. Allen-Bradley Bulletin 800H, no equal.
2. For hazardous locations, provide hermetically sealed emergency stop buttons. Allen-Bradley Bulletin 800R, no equal.

D. Thermostats

1. Thermostats shall be line voltage, heavy-duty type. Thermostats shall have off-auto switch with thermometer, 50° F to 140° F set point range, and motor current rated contacts.
2. Thermostats shall be Honeywell T631C-1020.

E. Control Relays

1. Control relays shall have 120-volt AC or 24-volt DC coils, except as noted; contacts shall be rated for the various circuit applications as shown on the drawings. Control relays shall be 10-ampere, multiple-contact, 300-volt, plug-in type with dust cover and sockets. If additional contacts are required, they shall be ganged.
2. Control relays for 120-volt AC application shall be as follows, no equal.
 - a. DPDT: Allen Bradley 700-HA32A1
 - b. Relay Base: 700-HN125, 10 amp, 300 volt
 - c. TPDT: Allen Bradley 700-HA33A1
 - d. Relay Base: 700-HN126, 10 amp, 300 volt
3. Control relays for 24-volt DC application shall be as follows, no equal.
 - a. DPDT: Allen Bradley 700-HA32Z24
 - b. Relay Base: 700-HN125, 10A, 300V
 - c. TPDT: Allen Bradley 700-HA33Z24
 - d. Relay Base: 700-HN126, 10 amp, 300 volt

4. Timing Control relays for 120-volt AC application shall be as follows, no equal.
 - a. DPDT: Allen Bradley 700-HR52TA17
 - b. Relay Base: 700-HN101, 10 amp, 300 volt
 - c. Retainer Clip: 700-HN131
5. Timing Control relays for 24-volt DC application shall be as follows, no equal.
 - a. DPDT: Allen Bradley 700-HR52TZ24
 - b. Relay Base: 700-HN101, 10 amp, 300 volt
 - c. Retainer Clip: 700-HN131

F. Terminal Blocks, Control Circuits, 120 Volt

1. Terminal Blocks: Terminal blocks shall be molded plastic with barriers and box lug terminals and shall be rated 25 amperes at 300 volts. White marking strips, fastened securely to the molded sections shall be provided and wire numbers or circuit identifications shall be marked thereon with permanent marking fluid.
2. Terminal blocks shall be Phoenix Contact UT-4 with mounting rack, no equal.

G. Intrusion Switches for Doors and Hatch Covers

1. Switches shall be NEMA 4X, Normally Open switches, held closed by the door or hatch. Intrusion switches shall be Allen Bradley 802T-AP, with roller lever arm 802T-W2B, no equal.

H. Pilot Lights

1. Pilot lights shall be oiltight type, push to test, complete with color of lens indicated on drawings and legend plate.
2. 120V/24VDC lamps shall be LED, push-to-test Allen-Bradley 800T-PTH16, no equal. Provide color lens as indicated on the drawings.

I. Intrusion Override Switches

1. Switches shall be 2-Position Key Operator, key removal left and right positions, Cutler-Hammer part number 10250T15113, no equal.
2. Contact block, shall be 1 N.C., 1 N.O, Cutler-Hammer part number 10250T1, no equal.
3. Key for key operator shall be Cutler-Hammer part number 10250ED824, Key, # H661, no equal.

4. Name plates for intrusion alarm override switches shall be as follows:

10250TS36	Custom Engraved Legend Plate, "INTRUSION ALARM", Position A
10250TM36	Custom Engraved Legend Plate, "NORMAL", Position A4 "OVERRIDE", Position D4

J. Time-of-Use Override Switches

1. Switches shall be 2-Position Key Operator, key removal left position only, Cutler-Hammer part number 10250T15112, no equal.
2. Contact block, shall be 2 Normally Open, Cutler-Hammer part number 10250T2, no equal.
3. Key for key operator shall be Cutler-Hammer part number, 10250T15112H501, Key #501CH, no equal.
4. Name plates for Time-of-Use override switches shall be as follows:

10250TS36	Custom Engraved Legend Plate, "TOU OVERRIDE", Position A
10250TM36	Custom Engraved Legend Plate, "OFF", Position A4 (Left) "ON", Position D4 (Right)

K. Intrinsically Safe Relay and Barrier

1. Intrinsically safe barrier for 24-volt DC dry contacts/relays shall be Ingram Products Two Channel Relay with Intrinsically Safe Inputs, Model Number ISR2-24V-10K.
2. Intrinsically safe barrier for 120-volt AC dry contacts/relays shall be Warrick Series 27A1D0.

PART 3 - EXECUTION

A. Spares

1. Provide three spare fuses of each type and ampere rating installed.

B. Intrusion Switches for Doors and Hatch Covers

1. Intrusion switches shall have two conductors wired back to terminal blocks in the PLC cabinet. The terminal blocks shall be jumpered in series to provide a single PLC input, such that any switch opening causes an open circuit. When all doors are secure, the circuit shall be closed. Intrusion switches shall be Allen Bradley 802T-AP series, no equal.

2. Reservoirs/wet well intrusion switches shall be NEMA type 4 watertight to protect the internal components against seepage, splashing, falling water, or hose-directed water, and shall be Allen Bradley 802X series, no equal.

END OF SECTION

SECTION 16110: RACEWAYS, PULL BOXES, AND FITTINGS

PART 1 - GENERAL

A. Description

This section describes materials and installation of raceway systems, whether concealed or exposed, above or below grade.

B. Related Work Specified Elsewhere

1. Earthwork and Grading: 02201
2. Concrete: 03300
3. General Electrical Requirements: 16010

C. Submittals

1. Shop drawings shall be submitted in accordance with the General Provisions and as specified herein.
2. Submit material list for all conduits, fittings, boxes, conduit boxes, mounting hardware, and related accessories.
3. Submit installation drawing including individual conduit numbers, routing, conduit sizes, circuit numbers contained in each conduit, and number and size of wires in each conduit.

PART 2 - MATERIALS

A. Conduit Related Materials

1. Conduit Mounting Strut:
 - a. Type 316 stainless steel for mounting of PVC coated rigid steel conduit and PVC non-metallic conduit.
 - b. Hot dipped galvanized for other conduit types.
 - c. Anodized aluminum and fiber-reinforced plastic (FRP) are acceptable in areas approved by the District.
2. Conduit Thruwall Seals:
 - a. Hot-dip galvanized.
 - b. PVC oversize sleeve.
 - c. Manufacturers: O-Z/Gedney, Type "WSK".

3. Couplings Connectors and Fittings:
 - a. Threaded.
 - b. Manufactured with same materials and process as corresponding conduit.
4. Conduit Fittings:
 - a. With wedge nut covers (Form 7), weathertight when located outdoors or in wet or corrosive locations (indicated on the drawings), matching type for corresponding conduit systems.
 - b. Manufacturers: Crouse-Hinds or Appleton, no equal
5. Galvanized Rigid Steel conduit Expansion Fittings for Exposed Locations:
 - a. Manufacturers: O-Z/Gedney, Type AX with jumper.
6. Galvanized Rigid Steel Conduit Expansion Fittings at Structural Expansion Joints:
 - a. Manufacturers: Spring City, Type D.
7. PVC Clamps and Clamp Backs:
 - a. PVC coated steel fasteners with Type 316 stainless steel bolts, nuts and hardware.
8. Fasteners for Galvanized Steel Conduit:
 - a. Galvanized steel fasteners with Type 316 stainless steel bolts, nuts and hardware.

B. Rigid Nonmetallic (PVC) Conduit and Fittings

1. PVC conduit shall be heavy wall, Schedule 40 conduit, and UL labeled for above ground and underground uses. The PVC conduit shall conform to NEMA TC-2 and UL-651.
2. Manufacturers shall be Cantex, JM Eagle, or Prime Conduit.

C. PVC-Coated Steel Conduit and Fittings

1. PVC-coated steel conduit and fittings shall be UL listed and shall conform to ANSI C80.1 and to UL-6. The thickness of the PVC-coating shall be .040-inch minimum.
2. Supports, hangers, unistrut, and clamps shall be Type 316 stainless steel. Bolts and nuts shall be Type 316 stainless steel.
3. A two-part urethane chemically cured coating shall be applied at a nominal 2-mil thickness to the interior of all conduit and fittings. The coating shall be sufficiently flexible to permit field bending of the conduit without cracking or flaking of the coating.

4. Every female opening shall have a PVC sleeve extending one conduit diameter or 2-inches beyond the opening, whichever is less. The inside diameter of the sleeve shall be the same as the outside diameter of the conduit before coating. The wall thickness of the sleeve shall be at least 40 mils.
5. All fittings, FD boxes, condulets, mounting hardware, and accessories shall be PVC coated. All conduit fittings shall be coated with the same interior urethane coating as described above. The screw heads on condulets shall be encapsulated with corrosion – resistant material by the manufacturer.
6. Manufacturers shall be Ocal, Inc. or Robroy Industries, no equal.

D. Galvanized Rigid Steel Conduit

1. Galvanized rigid steel conduit shall be domestic raw steel, made smooth, clean, and free of burrs and rough spots to enhance wire pulling.
2. Interior and exterior surfaces shall be coated with solid, unbroken layer of zinc.
3. Entire surface finish shall be coated with secondary chromate treatment applied over galvanizing able to extend surface protection and prevent oxidation.
4. Threads shall be protected by color coded end caps to provide quick trade size identification.
5. Manufacturers shall be LTV Steel Tubular Products Company, Galvite, Triangle PWC, Inc., Allied Tube and Conduit Corp., or Ocal, Inc.

E. Liquid-Tight Flexible Conduit and Connectors

1. Single strip steel, hot-dipped galvanized on all four sides prior to conduit fabrication. Overall PVC plastic jacket. Conduit sizes 1 1/4-inches and smaller shall include an integral copper bonding conductor wound spirally in the space between each convolution on the inside of the conduit. Conform to UL-360.
2. Compression-type bushing, manufactured with same material and process as corresponding conduit, and insulated throat and sealing O-ring.
3. Manufacturers shall be Anamet Anaconda Sealtite or Atkore Liquid-Tuff.

F. Outlet and Pull Boxes

1. Provide boxes for installation of electrical work, in compliance with codes and regulations. Use only deep boxes Type FD.
2. Use PVC-coated steel boxes for surface-mounted or exposed locations.
3. Provide pull boxes constructed of code-gage sheet steel finished with one coat of metal primer and one coat of primer sealer for pull boxes in dry locations. Box material shall match the conduit material.

G. Junction Boxes

1. Junction boxes shall be aluminum or stainless steel. Fiberglass junction boxes per District approval.

H. Explosion Proof Conduit Sealing Fittings

1. Manufacturers: Appleton, Crouse-Hinds 'EYS' and 'EYD'.

I. Identification Tags

1. The identification tag shall be rotary engraved with identifying letters and numbers. The circular plastic tag shall be 1/16-inch thick, 2-inch diameter, and the exterior shall be UV resistant 3 ply (color on both sides) lamicoid plastic by Rowmark, or Gravoply. Color shall be red for power, purple for control, and orange for signal.

PART 3 - EXECUTION

A. Installation

1. Conduit runs are shown schematically. Supports, pull boxes, junction boxes, and other ancillary equipment are not usually shown. Provide pull boxes and junction boxes where shown. In addition, provide pull boxes and junction boxes to permit pulling of wires without damage to the conductors or insulation.
2. Install conduit runs for lighting and receptacle circuits, whether or not indicated on the drawings, for circuit numbers indicated on the drawings.
3. Install conduit system to provide firm mechanical assemblies with electrical conductivity throughout.
4. Install ground bushings on all conduit not installed in to threaded hubs.
5. Install exposed conduits parallel to or at right angles to the lines of the building. Make right-angle bends in exposed conduit runs with standard elbows, threaded conduit fittings, or conduit bent to radii not less than those of standard elbows.
6. Route exposed conduit to preserve headroom, access space, and work space. Install conduit runs so they do not interfere with proper and safe operation of equipment and not block or interfere with ingress or egress, including equipment removal hatches.
7. Treat threaded joints of rigid steel conduit before installation of fittings. Coating material shall be T&B "Kor-Shield" or Crouse Hinds "STL", or equal.
8. Treat exposed threads of threaded joints of rigid steel conduit, after installation of fittings, with Enterprise Galvanizing "Galvabra".
9. Terminate rigid steel conduits with Myers type hubs with bushings. Install conduit squarely.

10. When terminating in threaded hubs, screw the conduit or fitting tight into the hub so that the end bears against the fire protection shoulder. When chase nipples are used, install the raceway and coupling square to the box and tighten the chase nipple with no exposed threads.
11. Label conduits with a label designating the destination of the conduit.
12. Conduits shall be capped during construction to prevent entrance of dirt, trash, and water.
13. Concealed conduit for future use shall be terminated in equipment or by galvanized couplings plugged flush with structural surfaces.
14. All conduits that enter enclosures shall be terminated by fittings that ensure that the NEMA rating of the enclosure is not affected or changed.
15. Unless otherwise indicated on the drawings, no exposed conduit shall be less than 3/4-inch.
16. After completing installation of 2-inch and larger conduit runs, snake conduits with conduit cleaner equipped with a cylindrical mandrel of diameter not less than 85% of nominal diameter of conduit. Remove and replace conduits through which the mandrel will not pass.
17. Clean and ensure that conduit runs are not crushed or creased. Verify that no foreign objects or obstructions are present in conduit prior to installing conductors.
18. Install runs between pull boxes or junction boxes with total bends equaling a maximum of 270 degrees. Install NEC required pull boxes at locations acceptable to the District Representative. Plug conduits brought into pull boxes, manholes, handholes, and other openings until used to prevent entrance of dirt, moisture and rodents.
19. Install duct bank raceway to external conduit size transitions at pull boxes and manholes.
20. For any existing conduits indicated to be reused, the Contractor shall snake conduits with conduit cleaner equipped with a cylindrical mandrel of diameter not less than 85% of the nominal diameter of the existing conduit. The Contractor shall remove and replace the existing conduits through which the mandrel will not pass.

B. Conduit Usage

Install the following types of raceway in the locations listed, unless otherwise indicated on the drawings.

Location	Conduit Type
Exposed outdoor, underground vaults, corrosive/chemical indoor locations and all exposed locations at Michelson Water Recycling Plant or Los Alisos Water Recycling Plant	PVC-coated rigid steel conduit.
Exposed dry indoor locations (except at Michelson Water Recycling Plant and Los Alisos Water Recycling Plant)	Rigid galvanized steel conduit.
Underground conduits	PVC-coated rigid steel conduit, or Schedule 40 PVC pipe with red colored reinforced concrete encasement. Use PVC-coated rigid steel conduit for stub-outs.
Final connections to motors or vibrating equipment	Liquid tight flexible conduit, limited to less than 3 feet in length for conduits less than 3 inches in diameter, and limited to less than 5 feet for conduit 3 inches and larger.
Final connections to lighting fixtures	Liquid tight flexible conduit limited to less than 4 feet in length.
All stub-outs entering or exiting concrete, masonry, earth, underground vaults, pull boxes, hand holes, etc.	PVC-coated rigid steel conduit shall extend a minimum of 6-inches above grade or finished floor. Stub-outs shall be connected to PVC-coated rigid steel 90-degree elbows before emergence.
Underground duct banks	PVC-coated rigid steel or Schedule 40 PVC conduit with red colored reinforced concrete encasement. Stub-outs entering switchboards, MCCs, PLCs, LCPs, VCPs, and cabinets shall be 3-inches maximum.
Conduit from VFD to motor	PVC-coated rigid steel conduit.

C. Underground Conduit

1. No underground conduit shall be smaller than 1-inch.
2. All concrete encasement shall be rebar reinforced. Concrete encased conduits shall have a minimum separation of 2-inches between conduits, 1-inch between conduit and rebar, and 3-inches from edge of rebar to edge of concrete encasement. The Contractor shall size all duct banks using these requirements.
3. Provide 30-inch minimum cover to top of conduit for underground conduits, including conduits that are encased or in duct banks. Provide 6-inch minimum sand above and below direct buried PVC-coated rigid steel conduit.
4. Provide burial depth, bedding, and backfill per utility company requirements for high voltage and service entrance conduits.
5. Where other utility piping systems are encountered or being installed along a raceway route, maintain a 12-inch minimum vertical separation between raceways and other systems at crossings. Maintain a 12-inch minimum separation between raceways and systems in parallel runs. Do not place raceways over valves or couplings in other piping systems. Refer conflicts with these requirements to the District for instructions before further work is done.

6. A minimum of 12-inch separation is required between power conduits and instrumentation/communication conduits.
7. Underground conduits shall be sloped to drain from buildings to the manholes.
8. Intercommunication, fiber optic, control, and instrumentation cables shall be separated from all power wiring in raceways, boxes, manholes, and handholes.

D. Conduit Supports

1. Support conduit at intervals and at locations as required by the NEC. Do not use perforated strap or plumbers tape for conduit supports.
2. Conduit on Concrete or Masonry: Use one-hole malleable iron straps with metallic expansion anchors and screws or from preset inserts. Use preset inserts in concrete when possible. Use pipe spacers (clamp backs) in wet locations. On plaster or stucco, use one-hole malleable iron straps with toggle bolts. Supports shall match the conduit being used.
3. Suspended Conduit:
 - a. Use factory-made, split-hinged pipe rings with threaded suspension rods sized for the weight to be carried (minimum 3/8-inch diameter).
 - b. For grouped conduits, construct racks with threaded rods and preformed unistrut channel cross members. Clamp each conduit individually to a cross member. Where rods are more than 2 feet long provide rigid sway bracing. Coat all ends of PVC-coated unistrut channel with sealer where cuts are made.
4. Supports at Structural Steel Members: Use beam clamps. Drilling or welding may be used only where indicated on the drawings.
5. Wherever conduit may be affected by dissimilar movements of the supporting structures or medium, provide flexible or expansion devices.

E. Damaged Conduit

1. Replace conduit damaged during or after installation. Replace crushed or clogged conduit or any conduit whose inner surface is damaged or not smooth.
2. Repair cuts, nicks, or abrasions in the zinc coating of galvanized conduit with galvanizing repair stick, Enterprise Galvanizing "Galvabra".
3. Repair PVC-coated rigid steel conduits per PVC-coating manufacturer's repair requirements.
4. For any damaged existing conduit, notify the District immediately for repair direction.

F. Empty Conduit

1. Cap spare conduits and provide pull string below threaded cap.
2. Provide bonding bushing and bond wire.

G. Sealing of Conduits

1. After cable has been installed and connected, conduit ends shall be sealed by non-hardening duct sealing compound forced into conduits to a minimum depth equal to the conduit diameter. This shall apply for all conduits at handholes, manholes, and building entrance junction boxes, and for 1-inch and larger conduit connections to equipment.
2. Conduits entering hazardous (classified) areas and submersible or explosion proof enclosures shall have sealing fittings with sealing compound.

H. Conduit Identification

1. Conduits shall be provided with identification tags in manholes, handholes, building entrances, junction boxes, and equipment. Identification tags shall be attached to conduits with nylon tie wraps and shall be positioned to be readily visible for inspection.
2. The identification tag shall be rotary engraved with identifying letters and numbers. The circular plastic tag shall be 1/16-inch thick, 2-inch diameter, and the exterior shall be UV resistant 3-ply (color on both sides) lamicoïd plastic by Rowmark or Gravoply. The color of the plastic tags shall be as shown in the table below.

Color	Conduit
Red with white core	Power
Purple with white core	Control
Orange with white core	Signal/Communication

The conduit tag ID shall be as indicated on the drawings.

3. Identification tags shall be attached to conduits with nylon tie wraps and shall be positioned to be readily visible for inspection.

I. Schedules

1. Conduit Sizes: In accordance with NEC, unless otherwise indicated on the drawings or specified as follows:
 - a. Exposed Conduit: Minimum 3/4 inches.
 - b. Schedule 40 PVC encased in concrete: Minimum 1 inch.
 - c. Buried Conduit: Minimum 1 inch.
 - d. Buried Conduit for Fiber Optic or Telemetry Cable: Minimum 2 inches.
 - e. Duct Banks: Minimum 2 inches.

END OF SECTION

SECTION 16120: CONDUCTORS AND CABLES

PART 1 - GENERAL

A. Description

1. This section describes materials and installation of conductors and cables for 600 volts and lower.

B. Related Work Specified Elsewhere

1. General Electrical Requirements: 16010
2. General Instrumentation and Control Requirements: 17000

C. Submittals

1. Shop drawings shall be submitted in accordance with the General Provisions, Section 16010 and as specified herein.
2. Submit material list for each conductor type. Indicate insulation material, conductor material, voltage rating, manufacturer, and other data pertinent to the specific cable, such as type shielding, number of pairs, and applicable standards.

PART 2 - MATERIALS

A. General

1. Material for conductor and cable shall be copper.

B. Low-Voltage Building Conductor

1. Low-voltage building conductors for use at 600V or less shall be stranded, 600-volt insulated, Type XHHW-2. Conductors No. 1/0 and larger shall be rated for continuous operation at 60-deg C. Conductors #1 and smaller shall be rated for continuous operations at 75-deg C.
2. Ground conductors shall be stranded and have 600-volt insulation and match the wire type of the power or control conductors for that circuit.
3. Power and lighting circuits shall use a minimum conductor size of No. 10 AWG. Power to instruments shall be No. 12 AWG.
4. Control Circuits shall use minimum conductor size of No. 14 AWG type THHN/THWN and rated for 600 volts.

C. Light Fixtures Conductor

1. Conductors in light fixtures shall be a minimum of No. 14 and rated for 600 volts.

D. Instrument Cable

1. Instrument cable shall be two or three 16 AWG stranded tinned-copper conductors, as shown on the drawings, and individually insulated with fully color-coded PVC rated at 300 volts. Instrument cable shall be insulated conductors twisted together and shielded with a spiral-wound metal foil tape overlapped for 100% shielding. The outer jacket shall be PVC.

E. Conductor Color Requirements

1. Conductors No. 8 AWG and smaller shall have factory color coding with solid color insulation. The Contractor shall not use onsite coloring of ends of conductors or apply colored plastic adhesives in lieu of factory color-coding.
2. Conductors No. 6 AWG and larger shall have factory color coding with solid color insulation.
3. PLC input/output circuit wiring shall be purple. PLC input/output circuit neutral wiring shall be colored as shown in the tables below.
4. Conductor color coding throughout the entire network of feeders and circuits (600 volts and below) shall be as follows:

480 / 277 Volt Circuits	
Circuit Designation	Color
Phase A	Brown
Phase B	Orange
Phase C	Yellow
Neutral	Gray
Ground	Green

120 / 240 Volt Circuits	
Circuit Designation	Color
Phase A	Black
Phase B	Red
Phase C	Blue
Neutral	White
Ground	Green
Control	Red
PLC Input / Output	Purple
PLC Output (neutral)	Purple w / White stripe
+ 24 VDC	Blue
- 24 VDC	Yellow

24 Volt DC Circuits	
Circuit Designation	Color
+ 24 VDC	Blue
- 24 VDC	Yellow
PLC Input / Output	Purple
PLC Input / Output (neutral)	Purple
Ground	Green

PART 3 - EXECUTION

A. Installation

1. Conductor and cable shall be installed in conduit unless otherwise noted.
2. To reduce pulling tension in long runs, cables shall be coated with pulling compound recommended by the cable manufacturer before being pulled into conduits.
3. Debris and moisture shall be removed from conduits, boxes, and cabinets prior to cable installation.
4. Conductors and cables shall be installed un-spliced. Splicing shall only be allowed with District approval.

B. Conductor Identification: General

1. Tagging of Conductors: Control conductors and instrument cables in motor control centers, panels, pull boxes, wireways, and at control device shall be tagged with heat shrink type markers: Brady, or Thomas and Betts. Control conductors and instrument cables shall be tagged with the same conductor numbers used in the approved PLC and loop drawing submittals. Self-laminating write on type or wrap around self-adhesive type will not be accepted.
2. Color coded conductors shall be provided throughout the entire network of feeders and circuits as required by this Specification.
3. Power conductors 120V shall be labeled with the panel and circuit number.

C. Conductor Identification: PLC Input/Output Circuits

1. The wire tagging of the PLC input/output conductors shall include the ISA tag number and PLC register number with bus, drop, rack, slot, and point. For example, wires to HS-100 terminating at bus 0, drop 0, rack 0, slot 2, point 1 shall be "HS-100/0.0.0.2.1".
2. Purple colored conductor for 120 Volt AC PLC input/output circuits is used as a worker safety precaution to identify foreign power sources in equipment. This requirement applies to internal wiring in the PLC enclosure cabinet, interconnecting wiring to individual devices and equipment, and the internal wiring at the equipment.

D. Low-Voltage Conductor Splices

1. Conductor splicing is not allowed unless specifically called out on the drawings or approved by the District. If splicing has been called out on the drawings, provide splices as described herein.
2. Solid Conductors: Solid conductor splices shall be manufactured by 3M "Scotchlok", Ideal "Super Nut," or Buchanan B-Cap.

3. Stranded Conductors No. 8 and Larger: Stranded conductor splices shall be T & B "Lock-Tie" connectors, Burndy Versitaps and heavy-duty connectors, or O.Z. solderless connectors.
4. Control Conductors: Use crimp connectors with tools by same manufacturer and/or UL listed for connectors of all stranded conductors.
5. Bolt-type connectors shall be retightened 24 to 48 hours after initial installation and before taping. Connections made with non-insulated type connectors shall be taped with rubber-type tape, one and one-half times the thickness of the conductor insulation, then covered with Scotch 33 tape.

END OF SECTION

SECTION 16135: CABINETS AND ENCLOSURES

PART 1 - GENERAL

A. Description

This section includes requirements for enclosures for electrical controls, instruments, terminal blocks, and similar equipment including, but not limited to, PLC, vendor-provided, and local control panels.

B. Related Work Specified Elsewhere

1. Painting and Coating: 09900
2. General Electrical Requirements: 16010
3. Miscellaneous Electrical Devices: 16051

C. Submittals

1. Shop drawings shall be submitted in accordance with the General Provisions, Section 16010 and as specified herein.
2. Heat calculations for PLC, HMI, VFD, and UPS enclosures shall be provided.

PART 2 - MATERIALS

A. General Enclosure Design Requirements

1. Unless approved by the District, enclosures for electrical controls, instruments, terminal blocks, and similar equipment shall be NEMA 4X 316 stainless steel and shall be compatible with the conduit system being used. Enclosures shall be dead front with 3-point pad-lockable handles. Additional latches needed to close the door shall not be acceptable. Control devices such as lights, pushbuttons, switches, relays shall be mounted on an interior swing out panel.
2. NEMA 4X Steel Enclosures:
 - a. Make enclosures from 12-gauge 316 stainless steel with seams that are continuously welded. Doors shall have full-length piano hinges with the door removable by pulling the stainless-steel hinge pin.
 - b. Provide a rolled lip around 3 sides of the door and around all sides of the enclosure opening.
 - c. Attach gasket with oil-resistant adhesive and hold it in place with steel retaining strips.
 - d. Hardware, such as clamps, screws, and hinge pins, hasp and staple shall be provided for padlocking.
 - e. Provide a print pocket for each enclosure.

- f. Do not paint NEMA 4X steel enclosures. Door fronts shall be ground smooth. Print pockets and interior panels shall be unfinished brushed stainless steel.
 - g. NEMA 4X steel enclosures shall be Hoffman Products.
3. NEMA 4X Fiberglass Enclosures:
- a. Provide enclosures that consist of base and cover that shall be heavy-duty hot compression molded from fiberglass reinforced polyester compound containing not less than 25 percent fiberglass by weight. Transparent covers, when required, shall be polycarbonate. The enclosures shall be provided with cover hinges manufactured from nonmetallic materials. The cover latch system shall be nonmetallic.
 - b. Provide the enclosures with gasket system of neoprene material cemented into a molded labyrinth on the cover.
 - c. Fiberglass enclosures shall be provided only when specifically called out as fiberglass on the drawings or with approval from the District.
 - d. NEMA 4X fiberglass enclosures shall be Carlon Products.

B. PLC, Vendor, or Local Control Panels

- 1. Panels shall be floor-mounted NEMA 12 (for indoor applications) or NEMA 4X 316 stainless steel gasketed enclosure with air conditioning units (for outdoor applications) and shall be constructed from 12-gage formed steel throughout. Access doors shall have continuous hinges with sealing clamps. All exposed edges and welds on the enclosure shall be ground smooth.
- 2. The interior shall be provided with a formed 12-gage subpanel for attaching surface-mounted components. The interior shall be painted with two coats of epoxy white paint.
- 3. PLC enclosures shall be Hoffman Products.

C. Cabinet Temperature

- 1. All cabinets containing heat sensitive equipment such as PLC, HMI, VFD, or UPS, that are not located in an air-conditioned room or air-conditioned building shall utilize a side mounted air conditioning unit to maintain an internal temperature range of 75 degrees to 95 degrees Fahrenheit.
- 2. The Contractor shall submit the heat calculations for approval.

PART 3 - EXECUTION

A. Installation

Install panels and enclosures in accessible locations and provide working clearances that meet NEC requirements for electrical equipment.

B. Enclosure Air Conditioning Installation

Side mounted air conditioning units installed on enclosures shall be installed in a manner that prevents condensation from damaging the electrical equipment and the enclosure. Top mounted air conditioning units are not allowed.

C. Panel Device and Component Mounting

1. General: All components, except those on the front panels, shall be mounted behind on fixed or swing-out panels; terminal blocks for field connections shall be mounted on fixed channels located near the bottom of the sections but clear of the conduit entry area. Fixed panels shall be located so as not to prevent access within the cabinets to other components, wiring, and terminal blocks on fixed panels or front panels.
2. All components shall be attached with screws and the subpanel shall be threaded. Rivets or back of panel nuts shall not be allowed.

D. PLC Enclosures

1. The Contractor shall provide at least two separate 120V circuits to each PLC cabinet. One circuit shall be for ancillary equipment such as lights, receptacles, fans or HVAC, and a second circuit shall be dedicated only for the UPS to power the PLC and selected instruments.
2. Each PLC interior shall be equipped with a 120-volt, 15-ampere duplex output and a single-pole, 15-ampere, 120-volt circuit breaker.
3. Provide a LED lamp and switch in the panel.
4. Provide a minimum of five (5) spare 120V/5A circuit breakers and five (5) spare 24VDC/5A circuit breakers.

E. Terminal Requirements for Field Wires

Terminal Blocks: Provide terminal blocks in the panel for interconnecting panel mounted devices to field wires. Do not terminate field wires directly on panel mounted devices.

F. Terminal to Wireway Clearance Requirement

Provide a minimum of 2 inches of space between terminal blocks and any wireway.

END OF SECTION

SECTION 16140: SWITCHES AND RECEPTACLES

PART 1 - GENERAL

A. Description

This section describes materials and installation of light switches and receptacles.

B. Related Work Specified Elsewhere

1. General Electrical Requirements: 16010

C. Submittals

1. Shop drawings shall be submitted in accordance with the General Provisions, Section 16010, and as specified herein.
2. Submit material list for each type of switch, receptacle, and cover plate. Indicate type, ratings, material, color, and manufacturer.

PART 2 - MATERIALS

A. Receptacles

1. Duplex Receptacles: Provide molded composition, ivory, specification grade receptacles. Duplex receptacles for 120-volt, single-phase, 3-wire service shall be rated 20 amperes, 125 volts, back or side wired, NEMA Type 5-20R.
2. 480 Volt Receptacles: Provide 480-volt, 30-ampere twist-lock receptacle and a spare plug, NEMA L16-30R and NEMA 16-30P.
3. Ground-Fault Circuit Interrupters (GFCI) rated receptacles shall be provided in outdoor locations with weatherproof while-in-use cover, process and mechanical area, electrical rooms, and as required in the National Electric Code (NEC), latest edition.

B. Switches

Switches shall be molded composition, ivory, specification grade, single pole, three way, and four way as shown on the drawings. For 120- or 277-Volt Lighting, provide switches rated for 20 amperes, 120-277-volt AC.

C. Cover Plates

1. Provide weather tight gasketed 316 stainless steel cover plates for exterior and underground receptacles with hinged covers. Provide Type 430 stainless steel plates in all other locations.
2. Provide 316 stainless steel cover plates for switches.

PART 3 - EXECUTION

A. Grounding

Provide a bonding jumper between the grounded outlet box and the receptacle ground terminal. Feed power to 120 volt AC receptacles a GFCI Type Circuit Breaker.

END OF SECTION

SECTION 16160: PANELBOARDS

PART 1 - GENERAL

A. Description

This section describes materials, testing, and installation of panelboards.

B. Related Work Specified Elsewhere

1. General Electrical Requirements: 16010
2. Cabinets and Enclosures: 16135
3. Low-Voltage Motor Control: 16155

C. Submittals

1. Shop drawings shall be submitted in accordance with the General Provisions, Section 16010 and as specified herein.
2. Provide ratings and characteristics including voltage ratings, bussing arrangement, continuous current ratings, fault current withstand ratings, neutral bus rating, enclosure type, ratings and arrangement of overcurrent protective devices, and mounting provisions.

PART 2 - MATERIALS

A. General

Dead front, safety type, with 120/208v, 277/480v, or 480v ratings as scheduled. Panelboards shall be circuit breaker type and suitable for the short circuit and duty ratings specified or at a minimum have the same short circuit rating as the upstream feeder circuit breaker, whichever rating is higher. Panelboards shall be three-phase 4-wire unless otherwise noted. Refer to Section 16010, Table 3.H for panelboard NEMA ratings. Panelboards shall be manufactured by Allen-Bradley, Square D, or Cutler Hammer.

B. Breakers

1. All breakers shall be molded-case type. Provide quick-make and quick-break toggle mechanism, inverse-time trip characteristics, and trip-free operation on overload or short circuit. Automatic tripping shall be indicated by a handle position between the manual OFF and ON position. Provide trip ratings as indicated in the panelboard schedules. Provide lock-on or lock-off devices as indicated on the drawings.
2. Single-pole breakers shall be full module size; two poles shall not be installed in a single module. Multiple circuit breakers shall be of the common-trip type having a single operating handle.

3. Furnish ground-fault circuit interrupter (GFCI), 5-mA trip, 10,000-ampere interrupting capacity circuit breakers as indicated and for all 120 volt AC receptacles circuits.

C. Circuit Breaker Connections

Circuit breaker current-carrying connections to the bus shall be of the bolted type, factory assembled.

D. Bus Bars

Bus bars shall be tinned copper. Provide a copper ground bus bar installed on the panelboard frame, bonded to the box, and containing at least 10 terminal screws.

E. Space Only

Where "space only" is noted on the drawings, provide connectors, mounting brackets and any other hardware necessary for the future insertion of an overcurrent device of the size indicated.

F. Nameplates

Provide nameplates as specified in Section 16010, General Electrical Devices. Designate the identifying nomenclature, voltage, and phase of the panel as shown on the drawings. For example, "PANEL A, 120/208-volt, three-phase, 4-wire, 100-ampere bus".

G. Enclosures

Refer to Section 16135, Cabinets and Enclosures for enclosure requirements.

PART 3 - EXECUTION

A. General

Install panelboards in accordance with manufacturer's recommendations.

B. Circuit Schedule

Provide typed circuit schedule listing permanently attached to the inside surface of the panelboard access door. Handwritten directories are unacceptable.

END OF SECTION

SECTION 16400: SERVICE AND DISTRIBUTION

PART 1 - GENERAL

A. Description

This Section outlines the electrical work for underground power service, power distribution and grounding, and forms a part of all other Sections of Division 16 unless otherwise specified.

B. Related Work Specified Elsewhere

1. General Electrical Requirements: 16010
2. Structure Earthwork: 02220
3. Concrete: 03300
4. Painting and Coating: 09900
5. Low Voltage Switchboards: 16443

C. Power Service

1. The power company shall supply alternating current at 60 Hertz and at the indicated voltage for the power service as shown on the drawings.
2. Underground service shall be complete and as shown on the drawings. The service installation shall conform to the power company service requirements.
3. Distribution: The power distribution system shall include equipment installations and underground wiring installations as shown on the drawings.
4. Grounding: System, structural, and equipment grounding installations shall be complete as indicated and required per governing codes.
 - a. Equipment grounding includes all non-current carrying metal parts of electrical equipment and wiring systems that shall be effectively grounded with a minimum of #4/0 cu. A.W.G. or as noted on the drawings.
 - b. Structural grounding includes all structural steel that shall be effectively grounded with #4/0 cu. A.W.G. or as noted on the drawings.
 - c. System grounding includes a solid ground connection to the neutral point of a system, transformer and rotating machine as indicated on the drawings and required by N.E.C.

D. Submittals

Shop drawings shall be submitted in accordance with the General Provisions and specified herein.

Submit material lists, shop drawings, reports, and technical data to the extent required in this Section and Section 16010 for District approval.

1. **Material Lists:** The material lists shall be complete and include all products specified in this Section, including the equipment that shall have shop drawings. The list shall include only one manufacturer for each product.
2. **Shop Drawings:** The equipment shop drawings shall be complete and include the following for the primary service, transformers, switchboards, and panelboards:
 - a. Plans shall show the equipment location, space requirements, clearances, conduit and anchor bolt locations.
 - b. Elevations shall show the vertical positions and arrangements of equipment and nameplates.
 - c. Details shall show the requirement enlarged small parts.
 - d. Dimensions shall be included on the shop drawings.
 - e. Weights for equipment and seismic anchoring requirement shall be included on the shop drawings.
 - f. Nameplate data shall include the nameplate material, heights of letters, and inscriptions.
3. **Technical Data:** Complete equipment descriptive, operation, and installation data shall be submitted with the shop drawings.
4. **Test Reports:** Copies of the Factory Test Reports shall be certified by the manufacturer and submitted to the District as specified in Section 16010.

PART 2 - PRODUCTS

A. General

Provide all equipment and materials, including proper space, and complete all of the power service, power distribution, and grounding installations as indicated, specified, and required. Refer to Sections 16010, 16110, 16120, and 16433 for conduits, conductors, switchboards, circuit breakers, and nameplates.

B. Handholes and Pull Boxes

Below Ground: Precast concrete handholes and pull boxes shall be provided as shown on the drawings, designed for H-20 bridge loading, and shall be Jensen Precast or Oldcastle. Knockouts shall be provided for connection to underground conduits. Covers shall be steel, bolt down traffic type. Sump shall be provided in the bottom section. Inside dimensions shall not be less than 24" W x 48" L x 36" D. Bottomless pull boxes are acceptable as approved by the District.

C. Service Equipment

Provide the metal enclosed, service equipment as shown on the drawings, specified and in accordance with the Power Company service requirements. The low voltage service equipment shall be supplied with 100 percent rated copper bus and shall be Square D, GE, Cutler Hammer, or IEM.

1. Provisions for Power Company metering, consisting of current transformers, demand meter, kilowatt-hour meter, and associated protective devices shall be made in switchboard as indicated on the drawings and as required by the Power Company.
2. Pull section shall be totally metal enclosed, full height, free standing and equipped with copper busses and connectors for the underground service conductors.
3. Main service switch shall be included in the service equipment as shown on the drawings, and specified in Section 16443. Provide a shunt trip as indicated. Interrupting rating shall be as indicated on the drawings.
4. Ground fault protection shall be provided. The system shall provide low-level ground fault protection, and shall be manufactured by Westinghouse, Square D, or Allen Bradley. The ground fault protection system shall be complete and consist of an adjustable relay, monitor panel, current sensor, and a disconnect device that actuates a shunt trip on the circuit breaker. The ground fault relay shall be solid state with an adjustable pickup setting. The sensor shall be a specially constructed current transformer, which encompasses the phase and neutral conductors. A monitor panel shall include visual indication when the circuit interrupter has opened on a ground fault, and a push-to-test button. The circuit disconnecting device shall be actuated when the current output of the sensor exceeds the pickup setting of the static relay, which trips the shunt mechanism on the circuit breaker.
5. Nameplates shall be provided for the service equipment in accordance with Section 16010, General Electrical Requirements.
6. Power Company approval of the proposed service equipment shall be obtained before shop drawings are submitted to the District for review and prior to fabrication.

PART 3 - EXECUTION

Not used.

END OF SECTION

SECTION 16450: GROUNDING

PART 1 - GENERAL

A. Description

This section includes materials, testing, and installation of electrical grounding.

B. Related Work Specified Elsewhere

1. General Electrical Requirements: 16010
2. Electrical testing: 16950

C. References

1. National Electrical Code Article 250

D. Submittals

1. Shop drawings shall be submitted in accordance with the General Provisions, Section 16010, and as specified herein.
2. Submit material list for all grounding materials and equipment. Indicate size, material, and manufacturer.

PART 2 - MATERIALS

A. Ground Conductors

All ground conductors shall be at least 12 AWG soft drawn copper cable or bar, bare or green-insulated in accordance with the NEC Table 250-94 and Table 250-95.

B. Ground Rods

Ground rods shall be copper-clad steel, minimum 3/4-inch diameter, and minimum 10 feet long, with hardened steel points.

C. Ground Clamps

Ground clamps for connection of ground wire to ground rod shall be bronze.

D. Ground Resistance Tester

The ground resistance tester shall be an instrument specifically designed for ground resistance testing.

E. Ground Well

Provide a ground rod well as shown on the drawings.

F. Ground Box

Unless otherwise specified on the plans, the ground box shall be in accordance with the following.

1. Ground box and frame shall be in accordance with IRWD Standard Drawing W-22.
2. Ground box cover shall be in accordance with IRWD Standard Drawing W-22 and shall be iron with letters "IRWD" and "GROUND" cast thereon. The cover shall be black and coated in accordance with Section 09900, Painting and Coating.

PART 3 - EXECUTION

A. Ground Electrode

1. Install a bare copper ground loop in the concrete footing for new buildings. Bring both ends of the loop to the ground bus within the switchboard. Provide ground conductors to all electrical equipment, motors, and tanks.
2. At well pump sites, install a bare copper ground conductor from the switchboard ground bus to the well casing.
3. Install concrete encased bare ground conductor in each duct bank.
4. Run grounding electrode system conductors continuously in duct banks, through manholes, handholes, through raceway boxes, and cable tray exteriors. Connect conductors to structure ground ring or grounding system to provide a continuous grounding electrode system.
5. Bond electrical enclosures, including metallic raceways, cable tray, panels, switchboards and other similar metallic panels, cases and devices associated with power, instrumentation, and control systems to the grounding electrode system.
6. Drive ground rods and install grounding conductors prior to construction of concrete slabs and duct banks. Extend grounding conductors through concrete to accessible points for grounding equipment and electrical enclosures. Install grounding system at each structure where switchgear, motor control centers, switchboards, panelboards, panels or other electrical equipment are installed.
7. Buried or concealed joints or terminations are not permitted.
8. Protect wires with a rigid steel conduit where wires stub up through slab at motor control center.
9. Provide either exothermic welded or mechanical connections for grounding cable to rods or cable.

B. Equipment Grounding

1. Connect the ground bus of the lighting panel to the ground bus within the motor control center.

2. Ground raceways and noncurrent carrying parts of electrical equipment in accordance with NEC Article 250. Use the rigid steel conduit system for equipment and enclosure grounding. Grounding through the conduit system shall be in excess of any ground conductors shown on the drawings. Circuits in nonmetallic conduit shall carry one ground conductor for equipment grounding.
3. Ground antenna mast to ground well (bus).
4. Install ground bushings at both ends of rigid conduit runs and bond ground bushings to the grounding system.

C. Ground Test Well

Provide a handhole and ground rod as detailed on the drawings to aid in performing ground testing and connecting additional ground rods if required by the test results. Connect ground wire from ground rod to motor control center ground bus as detailed on the drawings.

D. Tests

1. The Contractor shall notify the District a minimum of 48 hours prior to ground testing to allow for witness of all ground resistance testing.
2. Before making connections to the ground electrode, measure the resistance of the electrode to ground using a ground resistance tester. Perform the test not less than 14 days after the most recent rainfall and in the afternoon after any ground condensation (dew) has evaporated. A representative of the District shall witness test. If a resistance of 5 ohms or less is not obtained, provide a ground rod driven 6 inches below grade and connect to ground test well with No. 4 AWG bare copper wire and repeat the test. If the resistance is still above 5 ohms, inform the District.

END OF SECTION

SECTION 16460: TRANSFORMERS

PART 1 - GENERAL

A. Description

This section includes materials and installation of transformers.

B. Related Work Specified Elsewhere

1. General Electrical Requirements: 16010
2. Low-Voltage Motor Control: 16155

C. Submittals

1. Shop drawings shall be submitted in accordance with the General Provisions, Section 16010, and as specified herein.
2. Submit ratings and characteristics including voltage, phases, connection, enclosure type and dimensions, and conduit entry restrictions.

PART 2 - MATERIALS

A. General

1. Size (kVA), voltage, and phase of the transformers are indicated on the drawings.
2. Transformers to be UL listed and labeled where listing applies.
3. Transformers shall have copper windings.

B. Dry-Type Transformers (300 kVA and Below)

1. Construct transformers in accordance with ANSI C898.2, NEMA ST-20, and UL listed under the requirements of Standard 506.
2. Transformers rated 2 kVA and below shall have Class B, 80 C rise insulation system.
3. Transformers rated 3 through 25 kVA shall have Class F, 115 C rise insulation system.
4. Transformers 5 kVA and larger shall have two 2-1/2% FCBN and two 2-1/2% FCAN taps on the primary side.
5. Transformers 25 kVA through 300 kVA shall have Class F, 155 C rise insulation system or higher.

6. Core and coil shall be encapsulated in an insulating resin of the class equal to the temperature rise and shall be embedded in a resin and filler system to attenuate the sound level.
7. Transformers shall be Square D Company electro-magnetically shielded type.

PART 3 - EXECUTION

A. General

1. Set taps under load conditions for correct voltage.

END OF SECTION

SECTION 16640: CATHODIC PROTECTION AND JOINT BONDING

PART 1 - GENERAL

A. Description

This section describes materials and installation of cathodic protection and testing equipment including wiring, zinc anodes, joint bonding, test stations, reference cells, alumino-thermic welds, and flange insulation kits.

B. Related Work Specified Elsewhere

1. Trenching, Backfilling, & Compacting: 02223
2. Concrete: 03300
3. Painting & Coating: 09900
4. Facilities Identification: 15151

C. Submittals

1. Shop drawings shall be submitted in accordance with the General Provisions and as specified herein.
2. Submit manufacturer's catalog data on wire and cables, test stations, reference cells, thermic welds, insulation kits, dielectric coatings, and anodes.
3. Submit qualifications of company performing required testing and record keeping. The testing shall be performed under the direction and oversight of a registered corrosion engineer or certified NACE Cathodic Protection (CP) specialist.

PART 2 - MATERIALS

A. Alumino-Thermic Weld Materials

Cartridges and sleeves for welding test lead wires, joint bonding wires and anode lead wires to the pipe, shall be "Cadweld," or "Thermoweld." Based on the type of pipe (steel, ductile iron, or cast iron) to which the wire is to be welded, the cartridge type, size and weight shall be as recommended by the manufacturer.

B. Alumino-Thermic Weld Caps

Alumino-thermic weld caps shall incorporate a high-density polyethylene plastic sheet that has minimum thickness of 10 mils with a 165 mils thick protective adhesive as manufactured by Farwest Corrosion Control Company or Chase Corporation's Royston Products.

Design shall incorporate an elastomeric or a mastic-filled dome and a tunnel portion to contain lead wire from the alumino-thermic weld connection. The mastic coating shall be Carboline Bitumastic 50, Royston Products, Tnemec 46-465, or Tnemec 46H-413. Prior

to application of the mastic coating, the manufacturer's recommended primer shall be applied to exposed metal.

C. Coating Selection

Alumino-thermic connection coating shall be in accordance with the following.

<u>Pipe Material</u>	<u>Connection Coating</u>
Cement-mortar coated steel	Carboline Carboguard 890 VOC and mortar. A plastic weld cap shall not be used.
Carbon steel, Ductile iron	Thermic weld cap with mastic, Royston Handy Cap XL IP or Royston Handy Cap IP.

D. Test Station Boxes

Test station boxes shall be a minimum 10-inch diameter, 12-inch deep, precast concrete with a cast iron lid designed for H-20 traffic loading. "CPTS" shall be cast on the lid. Test boxes shall be Brooks Products 3-RT, Christy G05T, or Eisel Enterprises. Test boxes with terminal boards for anodes shall be rectangular in accordance with Section 03462, Precast Concrete Vaults and Meter Boxes. Test box lids shall be painted in accordance with Section 09900, Painting and Coating.

E. Pipe Leads

Unless noted otherwise, pipe leads shall be stranded copper wire with high molecular weight polyethylene (HMW/PE) insulation specifically designed for cathodic protection service and suitable for direct burial in corrosive soil or water. Wire gauge shall be as shown on IRWD Standard Drawings CP-1, CP-2, and CP-3. Polyethylene insulation shall conform to ASTM D1248, Type I, Class C, Grades E-4 and E-5. Each pipe lead shall be of sufficient length to extend from the attachment to the pipe to the test box or anode test box without a splice. Wires with cut or damaged insulation shall be rejected. Insulation color shall be as shown on the plans or IRWD Standard Drawings.

F. Joint Bonding Wires

Pipe joint bonding wires shall be AWG No. 4 stranded copper wire with minimum 7/64-inch thick high molecular weight polyethylene (HMW/PE) insulation rated for 600 volts. The number of conductors shall be as shown on the plans and/or IRWD Standard Drawings. Polyethylene insulation shall conform to ASTM D1248, Type I, Class C, Grade 5. Each bond wire shall be 18 inches in length for 18-inch pipes or less and 24 inches for pipes larger than 18-inch.

G. Flange Insulation Kits

Insulating material shall be of the type designated by the manufacturer as suitable for the operating temperature and pressure of the service. Flange insulation kits shall consist of:

1. Insulating Gaskets: Gaskets shall be Type E full-faced, 1/8-inch minimum thickness, dielectric neoprene faced phenolic. Gaskets shall be Advance Products & Systems, Inc. (APS), George Fischer Central Plastics, or Pipeline Seal & Insulator, Inc. (PSI).

2. Insulating Sleeves and Washers: Insulating stud sleeves and washers shall be one-piece and full-length, made of Minlon or Mylar. One 1/8-inch thick gasket shall be attached to the sleeve, while the other shall be loose. Single insulating washers and sleeves shall be used on buried insulating flanges. Double insulating washers and sleeves shall be used on insulating flanges above ground, in structures, or in vaults.
3. Insulating Washers for Bolts: Insulating washers shall be 1/8-inch thick glass-clad phenolic. Single insulating washers shall be used on buried insulating flanges. Double insulating washers and full length sleeves shall be used on insulating flanges above ground, in structures, or in vaults.
4. Steel Washers Over Insulating Washer: Steel backing washers shall be 1/8-inch thick Type 316 stainless steel.
5. Compatibility with Valves: Insulating flange kits are not compatible with most valve flanges. Where cathodic isolation is required near a valve, a flanged spool shall be installed adjacent to the valve; and the required insulating joint shall be installed at the opposite end of the spool from the valve. Refer to the project plans for specific details.
6. Manufacturers: Flange insulation kits shall be as manufactured by Advance Products & Systems, Inc. (APS), George Fischer Central Plastics, or Pipeline Seal & Insulator, Inc. (PSI).

H. Buried Insulating Flange External Coating

1. Primer: Primer shall be a blend of microcrystalline waxes, plasticizers and corrosion inhibitors having a paste-like consistency. The material shall have the following properties:

Pour Point	100°F -115°F
Flash Point	350°F min
Coverage (approx.)	1 gallon/100 sq. ft.
Color	Brown

The primer shall be Trenton Wax-Tape Primer.

2. Wax-Tape: Flange covering material shall be a plastic-fiber felt tape, saturated with a blend of microcrystalline waxes, plasticizers and corrosion inhibitors that is easily formable over irregular surfaces. The tape shall have the following properties:

Tape Width	6-inches
Saturant Pour Point	115°F - 125°F
Thickness	70 - 90 mils
Dielectric Strength	170 Volts/mil
Weight	4 lbs/sq yd
Color	Brown

The Wax-Tape shall be Trenton #1 Wax-Tape.

3. **Outer Covering:** The primed and wax-tape wrapped flange shall be covered with a plastic wrapper consisting of three each of 50 gauge, clear, polyvinylidene chloride, high cling membranes wound together as a single sheet. The material shall have the following properties:

Width	6-inches
Thickness	1 1/2 mils
Dielectric Strength	2000 Volts/mil
Water Absorption	negligible
Color	Clear

The outer covering shall be Trenton Poly-Ply.

I. Internal Insulating Flange Coating

Coating for the interior lining of the pipeline at the insulating flange shall be a two-part smooth white, thixotropic liquid epoxy consisting of 100 percent solids. Coating shall be Aquatapoxy Paint as manufactured by American Chemical Corporation.

J. Zinc Anodes

1. **Zinc Anode:** Anode shall conform to ASTM B418, Type II and shall be a prepackaged zinc alloy ingot having a chemical composition not exceeding the following limits:

Lead	0.003% Max.
Aluminum	0.005% Max.
Cadmium	0.003% Max.
Iron	0.0014% Max.
Copper	0.002% Max.
Zinc	Remainder

2. **Anode Weight and Dimensions:** Ingot weight and dimensions of the prepackaged zinc anode shall be as listed in the table below. Weights are minimum.

<u>ZINC ANODE SIZES FOR 1-INCH & 2-INCH BARE COPPER PIPE SERVICES</u>			
Copper Pipe Size (inches)	Copper Pipe Length (feet)	Zinc (Bare) Anode Size (inches)	Zinc (Bare) Anode Weight (lbs.)
1	0 to 45	1.4x1.4x30	15
1	45 to 90	2.0x2.0x30	30
2	0 to 22	1.4x1.4x30	15
2	22 to 45	2.0x2.0x30	30
2	45 to 70	2.0x2.0x48	45
2	70 to 90	2.0x2.0x60	60

Note: For copper pipe length greater than that listed above, additional Zinc Anodes of appropriate size shall be added as approved by the District.

3. **Anode Backfill:** Each zinc anode shall either be prepackaged in a permeable cloth bag with backfill of the following composition or installed bare and backfilled with material having the following composition:

Gypsum	75%
Powdered Bentonite	20%
Anhydrous Sodium Sulfate	5%

Backfill grains shall be capable of 100% passing through a 20 mesh screen and 50% passing through a 100 mesh screen.

The backfill shall be firmly packed around the anode by mechanical vibration, which will maintain the zinc ingot in the center of the cloth bag and surrounded by at least 1-inch of backfill. The packaged weight of the zinc anode and backfill shall be approximately twice the weight of the zinc anode ingot weight.

4. Steel Core: Anode shall be cast full length with an electro-galvanized 1/4-inch diameter steel core, which shall be exposed at one end for connection of the anode lead wire.
5. Anode Lead Wire: Anode lead wire shall be AWG No. 8 stranded copper wire with high-molecular weight polyethylene (HMW/PE) insulation suitable for direct burial use. HMW/PE insulation shall conform to ASTM D1248, Type 1, Class "C", Category 5, Grades E4 and E5 with tensile strengths J1, J3.

Wire shall be attached to the steel core with silver solder by the anode manufacturer. The connection shall be encapsulated in a heat-shrinkable sleeve. Anode lead wire shall be a minimum of 15 feet long and shall be of sufficient length to extend from the anode to the designated termination point without a splice and 3-feet of coiled wire shall be provided in the test box. Wires with cut or damaged insulation shall be rejected and replacement of the entire lead shall be required at the Contractor's expense.

6. Anode Manufacturers: Pre-packaged anodes with lead wire and bagged backfill shall be supplied by Northtown Company, Far West Corrosion Control Company, or Galvotech Alloys, Inc.

K. Identification Tags

The identification tag shall be rotary engraved with identifying letters and numbers. The circular plastic tag shall be 1/16-inch thick, 2-inch diameter, and the exterior shall be UV resistant 3 ply (color on both sides) lamicoic plastic by Rowmark or Gravoply. Color shall be Blue with a white core for potable, Purple with a white core for recycled, Light-Blue with white core for untreated, or Green with white core for sewer. IRWD shall provide the un-engraved plastic tags to the Contractor for engraving. See IRWD Standard Drawing CP-6 for details.

L. ID Tape

ID tape shall comply with Section 15151, Facilities Identification and per the IRWD Standard Drawings.

M. Mortar

Mortar used to repair concrete coated pipe after attachment of the various bond or test wires shall be fast drying, non-shrinkable type. Refer to Section 03300, Concrete.

N. Marker Paddles – Utility Marker

Brown colored polycarbonate marker paddles shall be installed adjacent to the location of each test station, anode bed, shunt box, and reference cell location. Marker paddles shall be as manufactured by Carsonite Composites, a Phillips Group Brand. Marker paddles shall have an IRWD logo and 1-inch high yellow letters affixed, indicating the particular cathodic appurtenance. Both logos and decal letters are available from the District upon request. Refer to the IRWD Standard Drawing G-2.

O. Pipe Clamps

Pipe clamps used to attach the zinc anode lead wire to the above ground copper riser portion of the copper water tubing shall be brass or copper and of a size to fit the tubing. The pipe clamp shall have a screw terminal suitable for an AWG No. 8 copper stranded wire.

P. Insulating Blanket

The insulating blanket shall be a 1/8-inch thick neoprene or butyl insulating material. The width and length of the blanket will vary due to diameter of the pipelines to be insulated. The width and length shall be 12-inches larger than the diameter of the largest pipeline to be insulated.

Q. Casing Seal

The casing seal shall be composed of an irradiated, semi-rigid polyolefin sleeve which when exposed to temperatures in excess of 250°F will shrink from its original diameter to a predetermined recovered diameter. Casing seal shall be as manufactured by Advance Products & Systems, Inc. (APS) or Pipeline Seal & Insulator, Inc. (PSI).

R. Reference Electrodes

Reference electrodes shall be copper-copper sulfate type, suitable for direct burial, and shall remain stable for at least ten years. The reference cell shall be capable of maintaining a potential within 15 millivolts of a freshly made cell while drawing 2 microamperes. Reference cells shall contain a barrier to inhibit migration of chloride ions from the soil into the reference cell.

Reference cell lead wires shall be AWG No. 8, stranded copper wire with high-molecular weight polyethylene (HMW/PE) insulation suitable for direct burial use. HMW/PE insulation shall conform to ASTM D1248, Type 1, Class "C", Category 5, Grades E4 and E5 with tensile strengths J1, J3.

The lead wire shall be silver soldered to the copper core of the reference cell with the connection epoxy sealed according to the manufacturer's recommendations. Copper-copper sulfate reference cells shall be located next to the pipe in "native soil" near the "spring line" of the pipe.

The reference cells shall be EDI Model UI-CUG manufactured by Electrochemical Devices, Inc., IonX40 Catalogue No. 14669 by M. C. Miller Company, Model CU1-UG by GMC Electrical, Inc., or Stelth Model SRE-002-CFY by Borin Manufacturing, Inc.

PART 3 - EXECUTION

A. General

Cathodic protection installation shall conform to NACE Publication RP0169 (Latest Revision) – *"Recommended Practice, Control of External Corrosion on Underground and Submerged Metallic Piping Systems"* and to NACE Publication RP0286 (Latest Revision) – *"Recommended Practice, Electrical Insulation of Cathodically Protected Pipelines"*.

B. Wire Attachments

Wire leads shall be attached to the pipe and shall terminate at the test box without a splice. A minimum of 3-feet of slack wire from each lead shall be coiled and remain in each test box.

C. Attachment of Wire to Pipe

1. Surface Preparation for Alumino-Thermic Welding: Any existing coating on the pipe shall be removed by making a 3-inch square window in the coating. The exposed metal surface shall be cleaned to produce a bright metal finish, equivalent to SSPC SP-10, "near-white".
2. Alumino-Thermic Weld: The attachment of copper wire shall be made using an alumino-thermic weld as shown on IRWD Standard Drawing CP-9. Remove only enough insulation from the wire to allow the weld connection to be made. The wire shall be held at a 30°- 45° angle to the surface when welding. One wire only shall be attached to each weld.
3. Weld Test: As soon as the weld is cool, the weld shall be tested by striking a sharp blow with a 3-pound hammer while pulling firmly on the wire. All unsound welds shall be rewelded and retested.
4. Wire Locations: Wires shall be attached to the top (horizontal) surface of the pipe. Where two or more wires are required, welds shall be at least 6-inches apart.
5. Alternative Attachment Methods: The weld mold may not fit between the pretension bars of concrete cylinder pipe, depending on the diameter and pressure class of the pipe. Alternate methods of attachment may include:
 - a. thermite welding the test wire to the bell ring at a joint; or
 - b. arc welding a 1/4-inch diameter steel bar, with test wire pre-attached, to the steel cylinder between pretension bars.

D. Dielectric Coating Over Thermic Weld Connection

After completing the thermic weld connection between the wire and the pipe, the connection shall be coated. Repairs to the cement mortar coating shall be of the same material and thickness as specified for the pipe.

E. Backfill Over Wire

Buried wires shall be installed at a minimum depth of cover of 36-inches below the street section, or 36-inches below finished grade for un-paved areas. The trench bottom shall be level and free of exposed rocks. The first 12-inches of backfill above and the first 12-inches below the cable shall be sand per District bedding requirements. The remainder of the trench zone shall be backfilled in accordance with Section 02223, Trenching, Backfilling and Compaction. Plastic ID tape shall be installed 12-inches above the wire.

F. Test Stations

1. Test Station Boxes: Test boxes shall be located as shown on the plans or IRWD Standard Drawings, and shall be positioned in the parkway or raised median, as close to above the pipeline as practical. Boxes shall be installed in accordance with the IRWD Standard Drawings.
2. Two-Wire Test Station Spacing: Two-wire test stations with boxes shall be placed at intervals not to exceed 500 feet and at the end-points of all metallic pipelines and casings.

G. Joint Bonding Wires

Joint bonding wires shall be installed on ferrous metal pipelines at all unwelded joints, fittings, valves, and flanges (excluding insulated flanges) as shown on the Cathodic Protection IRWD Standard Drawings. Two bond wires shall be welded across each joint for pipe diameters less than 18-inches. Three bond wires shall be welded across joint for pipe diameters 18-inches and larger. Bond wires shall be attached using the aluminothermic weld process. Bond wires shall not be attached to valve bodies, but instead to the valve flanges.

H. Flange Insulation Kits

Flange insulation kits shall be installed as follows:

1. Cleaning: Faces of flange pairs shall be cleaned of all dirt, rust or fouling materials which would interfere with a watertight joint and insulating properties of the flange kit.
2. Alignment: Alignment pins shall be used to properly align the flange and gasket. The manufacturer's recommended bolt tightening sequence shall be followed. Bolt insulation sleeves shall be centered within the insulation washers so that the insulating sleeve is not compressed and damaged.
3. Locations: A bonding test station shall be installed at each buried flange insulation. Two test wires shall be installed on each side of the buried insulator according to the details of the plans, these specifications, and IRWD Standard Drawings.
4. Insulation Kits at Valves: Flange insulation kits shall not be installed directly against valve flanges. A 24-inch long spool shall be installed adjacent to the valve so that the insulating flange kit may be installed on a standard pair of flanges.

I. External Insulating Flange Coating

1. Buried Insulating Flange Coating:
 - a. **Primer:** Surface shall be cleaned of all dirt, dust, and loose rust or mill scale by wire brush and by wiping with a clean cloth. The surface shall be dry. Apply primer by hand or brush. A thick coating of primer shall be worked into all crevices, around bolts and in threads, and shall completely cover all exposed metal surfaces. The primer should overlap the pipe coating by 3-inches minimum.
 - b. **Wax-Tape:** The wax-tape can be applied immediately after primer application. Short lengths of tape shall be cut and formed completely around each individual bolt and stud-end. After all bolts are covered, the tape shall be applied circumferentially and formed by hand into all voids and spaces. There shall be no gaps or air spaces under the tape. The tape shall be applied with at least 55% overlap.
 - c. **Outer Covering:** The clear plastic outer covering shall be applied by hand such that the material conforms and adheres to the wax-tape surface. Two layers of plastic outer wrapping shall be applied.
2. Above Ground Insulating Flange Tape Coating: All flange and pipe surfaces shall be clean and free of all dirt, grease, water, and other foreign material prior to installation of tape coating. The two separate tapes shall be half-lapped twice over the outer surface of the flange.

J. Internal Coating at Insulating Flange

The interior of the pipeline shall be coated for a distance of two pipe diameters in each direction away from the insulating flange. At an insulated valve flange, interior of pipeline shall be coated away from the valve for a distance of two pipe diameters. Coating shall be in accordance with Section 09900, Painting and Coating, System No. B-1 or B-2 as appropriate.

1. Surface Preparation: The surface preparation of the mortar lining shall consist of wire brushing to remove all loose mortar to provide a suitable surface for adhesion of the coating.
2. Application: Coating shall be applied by brushing until a minimum coating thickness of 20 mils is achieved. Each ensuing coat shall be applied before subsequent coat cures, usually within 3 to 6 hours after subsequent coat has been applied.

K. Zinc Anodes

Where called for on the drawings, prepackaged zinc anodes shall be installed in excavated, drilled, or punched holes a minimum of 3-inches larger in diameter than the prepackaged anode diameter. Anodes shall be installed below the level of the service main, with a minimum separation of 2-feet between the copper water tubing and the zinc anode maintained at all times. Anodes shall not be lowered, transported, handled, or lifted by the lead wire.

1. **Backfilling:** After the prepackaged anode is placed in the hole, water shall be poured into the hole so that the anode is completely covered with water. Stone-free native soil shall then be used to backfill the anode hole in accordance with Section 02223, Trenching, Backfilling and Compacting. Imported sand shall not be used for backfilling. The anode hole shall be backfilled in stages and carefully compacted to ensure that no voids exist around the bag and that the bag and anode wire are not damaged. After backfill is level with the top of the anode, a minimum of 15 gallons of water shall be poured into the hole to completely saturate the soil backfill. More water shall be added if it is suspected that the backfill is not completely saturated. Care shall be taken to avoid damage to the anode and anode lead wires.
2. **Anode Lead Wire:** The anode lead wire shall run to the point of connection at the end of the pipe run in the meter box. The anode lead wire shall be clamped to the copper-tubing riser. Sufficient slack shall be provided in the wire, and it shall be coiled in the meter box for attachment to a future point of connection at the water meter. At combination air release and vacuum relief valves the anode lead wire shall run through the concrete pad and shall be clamped to the riser as shown in the IRWD Standard Drawings. At blow-offs and manual air releases, anode lead wire shall be coiled in the valve box and clamped to the riser.

L. Identification Tags

Identification tags shall be securely attached to each of the wires in the test box using UV rated zip ties rated to hold 50 pounds.

M. Marker Paddles – Utility Markers

Utility markers shall be installed per IRWD Standard Drawing G-2 at locations shown on IRWD Standard Drawing CP-7 or as directed by the District Representative.

N. Insulating Blanket

Install an insulating blanket as shown in the Project Plans between any metallic pipelines that cross or parallel each other when the distance between the two pipelines is less than 18-inches.

O. Earthwork

Trenching, backfilling, and compacting shall be in accordance with Section 02223, Trenching, Backfilling, & Compacting.

P. Required Test and Record Keeping

The Contractor shall furnish all necessary equipment, material and qualified personnel required to perform all tests described herein.

1. **Continuity Tests:** The Contractor shall notify the District Representative when continuity bonding has been completed and all test boxes have been completed. A registered corrosion engineer or certified NACE CP specialist retained by the Contractor shall oversee and certify the testing and measuring of the electrical continuity of metallic pipelines. The pipeline shall be considered electrically continuous when the measured longitudinal resistance of the pipeline between

each pair of adjacent test stations is no greater than 20 percent higher than the theoretical resistance of that section of pipeline.

If tests indicate that adequate electrical continuity has not been achieved, the Contractor shall excavate to investigate and locate improperly bonded joints and shall make repairs until electrical continuity is achieved to the satisfaction of the District.

2. **Test Stations:** The Contractor shall notify the District Representative when test station wires are ready for testing. The wires shall remain disconnected to facilitate testing. A registered corrosion engineer or certified NACE CP specialist retained by the Contractor shall oversee and certify the tests to certify that none of the wires were damaged during the installation. If the test indicates damage, the entire wire shall be replaced and retested at the Contractor's expense.

Records shall be made of all test stations and reference electrodes tested and submitted to the District.

3. **Insulation Joints:** The Contractor shall test each insulated joint with the insulator tester in accordance with the manufacturer's written instructions. All damaged or defective insulation parts shall be replaced and retested. Records shall be kept of all insulated joint tests and shall be submitted to the District.
4. **Anode and Pipe Lead Wire Integrity Tests:** After the pipe and anodes are buried, the pipe lead wire and anode lead wire trenches are backfilled, and the test boxes are installed, the Contractor shall notify the District Representative that the anode and pipe lead wires are ready for testing. The wires shall remain disconnected to facilitate testing. A registered corrosion engineer or certified NACE CP specialist retained by the Contractor shall oversee and certify the tests to confirm that none of the anode wires or pipe lead wires were damaged during the installation. Each anode lead wire will be tested for electrical continuity to the anode by measuring the anode's potential with respect to a copper copper-sulfate reference electrode. The measured open circuit potential of the anode shall be as specified in the table below or as specified by the manufacturer and approved by the District Representative.

Measured Open Circuit Potential for Anodes	
Anode Type	Minimum Measured Open Circuit Potential (Volts)
High Potential Magnesium Anode	1.7
Standard Magnesium Anode	1.4
Zinc Anodes	1.0

5. **Acceptance:** The Contractor shall submit a certified report by the corrosion engineer stating that the facilities are performing satisfactorily. All tests made must be reviewed and approved by the District before the corrosion control work is accepted. The District reserves the right to spot check any or all tests performed by the Contractor. All construction defects must be repaired and retested before the final acceptance is made. All unacceptable tests must be re-performed by the Contractor at no additional cost to the District. Contractor shall hook up all lead wires after testing is completed.

END OF SECTION

SECTION 16950: ELECTRICAL TESTING

PART 1 - GENERAL

A. Description

1. The Contractor shall retain an independent InterNational Electrical Testing Association (NETA) member Engineering and Testing Firm (Testing Firm) to perform specified on site acceptance testing of the project electrical power distribution system and utilized equipment covered by this contract.
2. The Testing Firm shall verify the protective device settings and appropriate arc flash labels are provided and installed in accordance with Section 16010, General Electrical Requirements.

B. Related Work Specified Elsewhere

1. Testing, Training, and Facility Startup: 01510
2. General Electrical Requirements: 16010
3. Grounding: 16450

C. References

1. InterNational Electrical Testing Association (NETA):
 - a. ATS-2017 – Standard for Acceptance Testing Specifications for Electrical Power Distribution Equipment and Systems.

D. Submittals

1. Pre-Test Submittals:
 - a. Testing service qualifications.
 - b. Test personnel qualifications, including resumes.
 - c. Equipment testing schedule.
 - d. Test data forms.
2. Post-Test Submittals:
 - a. Summary of testing for the project.
 - b. Description of the equipment tested.
 - c. Description of the test and detailed test procedures.
 - d. Test results.

- e. Conclusions and recommendations.
- f. Completed test forms, including witness' signatures.
- g. List of test equipment and calibration documents.
- h. Date and time of testing.
- i. Include the following data, in tabular format, for each piece of equipment:
 - i. Circuit number.
 - ii. Equipment or motor name and tag number, where applicable.
 - iii. Nameplate full-load-ampere rating.
 - iv. Motor service factor.
 - v. Motor ambient temperature rating.
 - vi. Overload relay rating.
 - vii. Measured full load current.
 - viii. Measured discharge pressures, where applicable.
- 3. Submit equipment test schedule no later than fourteen (14) days prior to the scheduled date of testing.
- 4. All wiring corrections or changes shall be updated in the O&M manual, and shall be submitted to and approved by the District.

E. Quality Assurance

- 1. The Contractor shall retain a qualified engineering appraisal and testing organization to provide inspections, testing, and evaluation of test results to determine that the equipment designated herein is furnished in accordance with the specifications and is installed and adjusted for successful energization and operation.
- 2. Testing Firm:
 - a. Obtain services of an independent testing service firm that meets the Federal OSHA criteria for accreditation of testing laboratories, Title 29, Part 1910.7 and has a work history and qualifications acceptable to the District Representative.
 - b. The appraisal and testing organization shall have two or more years of experience related to the appraisal and testing of equipment designated herein.
 - c. The managing or supervising representatives of the appraisal and testing organization shall have extensive knowledge of the products involved and at least two years experience conducting appraisals and tests. All testing shall be conducted under the supervision of the managing or supervising representatives.
 - d. Testing technicians shall be trained and experienced in the testing they perform.

- e. The engineering appraisal and testing organization shall utilize comprehensive report forms to document engineering appraisal and test results on all equipment and products. Upon completion of the work, the report forms shall be signed by the managing or supervising engineering representative and included in the final report.
- f. Testing shall be done in accordance with the manufacturer's instructions, these specifications, and applicable ANSI, ASTM and NEMA standards. Applicable product instructions shall be furnished to the District for review.
- g. The testing services and manufacturing firms shall be the following.
 - i. Power Systems Testing Company
 - ii. Electrical Reliability Services - Vertiv
 - iii. Hampton Tedder Technical Services
- h. Testing service or testing personnel may be accepted or rejected based upon, but not limited to, the testing equipment intended to be used and the qualifications of the firm and/or proposed personnel.

PART 2 - MATERIALS

Not applicable.

PART 3 - EXECUTION

A. Examination

Prior to performing the electrical testing, the Contractor shall perform the following at a minimum.

1. Verify that electrical work is free from improper grounds, short circuits, and overloads.
2. Verify correctness of wiring first by visual comparison of the conductor connections with connection diagrams.
3. Make individual circuit continuity checks by using electrical circuit testers.
4. Verify that the equipment has received a certificate of proper installation signed by the manufacturer.

B. Acceptance Testing

1. Perform testing and allow the District Representative to witness testing. Notify the District Representative a minimum of seven (7) days in advance of any scheduled test.
2. Perform electrical acceptance testing in accordance with NETA Standards.

3. Perform tests to assure that electrical equipment specified to be tested will operate within industry and manufacturer's published tolerances and will perform safely. Record test result data, which will be used as the baseline for future tests.
4. Testing of installed equipment shall result in acceptable test data. Equipment for which acceptable test data has not been submitted, or has been submitted but rejected, shall be deemed as not meeting the contract requirements.
5. Conduct 3-point fall of potential ground test by using equipment provided by one of the following manufacturers.
 - a. Biddle Company
 - b. Associated Research
6. Test insulation resistance of circuits. Test each complete circuit prior to energizing. Insulation resistance between conductors and between each conductor and ground shall not be less than 25 megohms. Repair or replace wires or cables in circuits that do not pass this test, and repeat the test until the criteria are met.
7. Test project electrical equipment, including 4 kV and 600 volt electrical distribution equipment, motor control centers, and grounding. Prepare test reports for each individual piece of equipment. The following types of electrical equipment shall be tested according to the requirements specified herein. Refer to the Contract Documents to identify the electrical components that require electrical testing including, but not limited to, the following.
 - a. Insulated case circuit breaker
 - b. Molded case circuit breaker
 - c. Motor circuit protector, 100 HP and above
 - d. Motors, 50 HP and above
 - e. Grounding electrode systems and equipment grounding system (refer to Section 16450, Grounding, for additional requirements)
 - f. Protective relays (relay settings shall be as documented in the project coordination study)
 - g. Three phase power transformers
8. Ground Fault Protective Equipment: The ground-fault protection system shall be performance tested after installation in accordance with NEC 230-95C. Submit a written record of the test to the District Representative. Label on panel above the device with certification and values. Record current pickup level and time delay settings to which the equipment was finally adjusted. Measure and record relay pickup current and the relay time delay at two values above pickup. Test for correct system operation at 57% rated voltage. If relay pickup current is not within 5% of the manufacturer's calibration marks or fixed setting or relay timing does not conform with manufacturer's published time-current characteristic curves, repair or replace equipment and repeat test.

9. Motor Operating Test: Run each motor as nearly as possible to rated operating conditions. Record current in each phase of each motor 1/2 hp and larger and submit to the District Representative. Repair or replace motor or driven equipment if current exceeds motor nameplate current.
10. Power Company Voltage Test: When the installation is essentially complete and the facility is in operation, check the voltage at the point of termination of the power company supply system to the project. Check voltage amplitude and balance between phases for loaded and unloaded conditions. If the unbalance (as defined by NEMA) exceeds 1%, or if the voltage varies throughout the day and from loaded to unloaded conditions more than $\pm 5\%$ of nominal, make a written request to the power company that the condition be corrected. If corrections are not made, request that the power company official provide a written statement that the voltage variations and/or unbalance are within their normal standards.
11. Reduced Energy Maintenance Switch (REMS) Test: REMS settings shall be enabled and tested in accordance with manufacturer recommendations. At a minimum, the Contractor shall perform a continuity test to ensure correct installation. REMS settings shall be per the coordination study required in Section 16010, General Electrical Requirements. The Contractor shall record REMS trip settings and return REMS to the disabled position after testing is complete.

C. Summary Test Report

Upon completion of testing, submit summary test report for all required tests.

END OF SECTION

SECTION 17000: GENERAL INSTRUMENTATION CONTROL REQUIREMENTS

PART 1 - GENERAL

A. Description

1. This section includes materials, testing, and installation of instrumentation and programmable logic control systems as specified herein and indicated on the drawings.
2. These specifications shall not be interpreted as permission or direction to violate any governing code or ordinance. Equipment, materials, and workmanship shall comply with the latest revisions of the following codes and standards:
 - a. Instrumentation: Instrument Society of America (ISA).
 - b. Wiring: National Electrical Code (NEC), ISA S5.3 and S5.4, 1976.
 - c. Control Panels and Equipment: NEMA, UL, and ANSI.
 - d. Control Logic: Joint Industrial Council (JIC).
 - e. Piping: ANSI B-31.3 (instrumentation piping).

B. Related Work Specified Elsewhere

1. One-year Guarantee: General Provisions
2. Permits and Licenses: General Provisions
3. Testing, Training, and Facility Start-up: General Requirements 01510
4. Division 16
5. Instrumentation and Control System Testing and Start-Up: 17332

C. Submittals

1. Detailed Systems Drawings and Data: The submittal shall consist of detailed drawings and data prepared and organized by the Contractor. These drawings and data shall be submitted as a complete package at one time. At a minimum, the complete package shall include the following.
 - a. Submittals shall be in PDF format and arranged for convenient use including tabs, all indexed, and cross-referenced. The final O&M manuals shall be in a three-ring binder including all tabs.
 - b. Detailed JIC-style schematic diagrams of each discrete input/output (I/O) point.
 - c. Detailed instrumentation diagrams of each analog I/O instrumentation and control loop, per ISA S5.3 and S5.4 standards.

- d. Detailed programmable logic controller (PLC) loop diagrams.
- e. Data sheets for each component, together with a technical product brochure or bulletin. The data sheets shall show:
 - i. Component name.
 - ii. Manufacturer's model number.
 - iii. Project tag number.
 - iv. Project location.
 - v. Input and output characteristics.
 - vi. Scale range and units (if any) and multiplier (if any).
 - vii. Requirements for electric supply (if any).
2. The data sheets shall be grouped together in the submittal by systems or loops as a separate group for each system or loop. If within a single system or loop, a single component is employed more than once, one data sheet with one brochure or bulletin may cover all identical uses of that component in that system.
3. Component interconnect drawings showing the interconnecting wiring between each component including equipment supplied under other sections requiring interfacing with the control system.
4. Arrangement and construction drawings for consoles, control panels, and for other special enclosed assemblies for field installation. These drawings shall include dimensions, identification of all components, preparation and finish data, nameplates, and the like. These drawings shall also include enough details to define the style and overall appearance of the assembly.
5. Installation, mounting, and anchoring detail for all components or entry details.
6. Electronic files of shop drawings: The electronic version of the final approved shop drawings in the latest AutoCAD format.
7. Complete detailed bill of materials.

D. Qualifications of Contractor

1. The Contractor shall select a prequalified Instrumentation Systems and Control Panel Supplier from the table below. All instrumentation systems and control panels shall be supplied, installed, calibrated, and tested by the following prequalified Instrumentation Systems and Control Panel Suppliers.

<p>Mr. Jeff Sanders George T. Hall Company GTH-Anaheim 1605 East Gene Autry Way Anaheim, CA 92805 Phone: 619-623-4579 FAX: 619-297-2917 jsanders@georgethall.com</p>	<p>Mr. Kris Turk KDC Systems, a Division of KDC Inc. 4462 Corporate Center Drive Los Alamitos, CA 90720 Phone : 714-484-2374 kturk@kdc-systems.com</p>	<p>Mr. Ray Winstead Morrow-Meadows Corp. 620 Reyes Drive Walnut, CA 91789 Phone: 909-869-7104 rwinstead@morrow-meadows.com</p>
<p>Mr. Salib Mansour Soffa Electric, Inc. 5901 Corvette Street Commerce, CA 90040 Phone: 323-728-0230 FAX: 323-887-8076 salib.mansour@soffaelectric.com sales@soffaelectric.com</p>	<p>Mrs. Yvette Quattrocchi Sulzer EMS Inc. 620 South Rancho Avenue Colton, CA 92324 Phone: 714-907-7098 yvette.quattrocchi@sulzer.com</p>	<p>Mr. Scott Ashton Technical Systems Inc. 36-B Mauchly Irvine, CA 92618 Phone: 949-590-8201 FAX: 425-775-9074 scotta@tsicontrols.com</p>
<p>Mr. Tom Smith Mr. John Wright TESCO Controls, Inc. 8440 Florin Road Sacramento, CA 95828 Phone: 916-395-8800 tsmith@tescocontrols.com jwright@tescocontrols.com sales@tescocontrols.com</p>	<p>Mr. Titus Crabb Mr. Kevin Smith Vertech 16 Technology Dr. #118 Irvine, CA 92618 Phone: 949-301-5874 Phoenix Office: 480-756-2300 tcraab@verttech.com ksmith@verttech.com</p>	

E. Responsibilities of Contractor and Instrumentation Systems and Control Panel Supplier

1. The Contractor and Instrumentation Systems and Control Panel Supplier shall furnish and install all proposed hardware as shown on the drawings and as specified herein. The Contractor and Instrumentation Systems and Control Panel Supplier, including its vendors, shall have unit responsibility for all the system hardware.
2. The Contractor and Instrumentation Systems and Control Panel Supplier shall furnish the following:
 - a. Instrumentation equipment, programmable logic control systems, and control panels, including:
 - i. Spare parts.
 - ii. Special tools and test equipment required by the supplier.
 - iii. Installation, integration, and testing.
 - iv. Documentation.
 - v. Operator training.
 - vi. Warranty.

- vii. Shipping and receiving.
3. All calibration and final checkout of the instrumentation and programmable logic control system shall be witnessed by the District to determine if the system complies with the contract documents. The Contractor shall notify the District a minimum of seven days prior to the start of witness testing.
 4. The Contractor and Instrumentation Systems and Control Panel Supplier shall be responsible for coordinating and interfacing with equipment supplied under these contract documents which are an integral part of the system. Interfacing shall be incorporated in the detailed systems drawings and data section of the contract documents.
 5. The District will perform the system integration and serve as the System Integrator (SI). As part of the system integration, the District will provide programs for PLC hardware, Human Machine Interface (HMI) and Supervisory Control and Data Acquisition (SCADA) as described in the contract documents, unless otherwise noted.
 6. The District will provide Local HMI programs for HMI hardware shown on the contract documents, unless otherwise noted in the contract documents.
 7. All equipment vendor package systems shall be provided complete with all PLC and HMI programming. Coordinate the equipment vendor package programming with the District to ensure all hard I/O and data exchange requirements are acceptable. The equipment vendor for each vendor package system shall submit system control strategies and I/O lists to the District for approval.
 8. Control descriptions of the system operation and PLC functions are provided in the contract documents to assist the Contractor and Instrumentation Systems and Control Panel Supplier to understand the complete system and its operation. The following requirements shall apply to the contract:
 - a. The Contractor and Instrumentation Systems and Control Panel Supplier shall be responsible for all aspects of the hardware installation.
 - b. The Contractor and Instrumentation Systems and Control Panel Supplier, in cooperation with the SI, shall be responsible for all aspects of testing in accordance with General Provision Section 01510, Testing, Training, and Facility Start-up and Section 17332, Instrumentation and Control Systems Testing and Start-up.
 - i. The SI, Contractor, and Instrumentation Systems and Control Panel Supplier shall be jointly responsible for troubleshooting system operational failures to resolve cause of malfunctions or deficiencies which (a) cause shutdown or partial operation of the facility or (b) result in performance that is less than specified.
 9. The Contractor and Instrumentation Systems and Control Panel Supplier shall provide a PLC system whose input and output configuration complies with the requirements of the contract documents, including specific I/O register assignments when applicable. The Contractor and Instrumentation Systems and Control Panel Supplier shall provide a hardware configuration that properly interfaces with the

PLC program provided by the SI. The Contractor and Instrumentation Systems and Control Panel Supplier shall notify the District of any changes to the input/output configurations described by the contract documents at the time of the submittal of shop drawings. After submittal review, the Contractor shall continue to be responsible for notifying the District and SI immediately of any changes that impact the PLC input/output configuration as defined in the contract documents and from all submittal, RFI, or change order responses.

F. Guarantee

The Contractor and Instrumentation Systems and Control Panel Supplier shall repair or replace defective components, rectify malfunctions, correct software problems (for any software supplied by the Contractor or Instrumentation Systems and Control Panel Supplier), and correct faulty workmanship, at no additional cost to the District during the guarantee period. To fulfill this obligation, technical service personnel designated by the Contractor and Instrumentation Systems and Control Panel Supplier who was originally assigned project responsibility. The Contractor and Instrumentation Systems and Control Panel Supplier shall make corrections within five calendar days after notification by the District.

PART 2 - MATERIALS

A. Designation of Components

In these specifications and on the plans, all systems, and other elements are represented schematically and are designated by numbers, as derived from criteria in Instrument Society of America Standards. The nomenclature and numbers designated herein and on the plans shall be employed exclusively throughout shop drawings, data sheets, and the like. Any other symbols, designations, and nomenclature unique to a manufacturer's standard methods shall not replace those prescribed above, as used herein, and on the plans.

B. Instrument Tagging

1. The Contractor shall attach a stainless steel tag to the instrument at the factory or in the field and shall permanently mark the stainless steel tag with the instrument tag number.
2. The manufacturer's standard metal nameplate shall denote, as a minimum, the model number, serial number, operating electrical voltage and amperage (when applicable), and date of manufacturer.

C. Instrument System Power

1. Power provided for the instrument system shall be 120-volt AC, single phase from a single source. This system shall supply 100% of the control power for the PLC and instruments. Provide battery backup and/or UPS systems as required by the contract documents.
2. Where DC power supplies are not furnished integral with any one instrument system loop, the Contractor and Instrumentation Systems and Control Panel Supplier shall provide separate solid-state power supplies, breakers, fuses, terminal blocks and din rail as needed.

D. Matching Style, Appearance and Type

1. All display instruments of each type shall represent the same outward appearance, having the same physical size and shape and the same size and style of numbers and pointers.

PART 3 - EXECUTION

A. Installation

1. The drawings indicate connections for typical equipment only. If the equipment furnished is different from what is shown, provide the modifications necessary for a safe and properly operating installation in accordance with the equipment manufacturer's recommendations.
2. The drawings indicate diagrammatically the desired location and arrangement of equipment. Field determine exact location based on physical size and arrangement of equipment, finished elevations, and obstructions.
3. Work or equipment not indicated or specified, which is necessary for the complete and proper operation of the instrumentation and control systems, shall be provided without additional cost to the District.

B. Uniformity of Components

1. Components that perform the same or similar functions shall, to the greatest degree possible, be of the same or similar type, the same manufacturer, the same grade of construction, the same size, and the same appearance. This includes coordination with vendor package systems.

C. Mounting of Equipment and Accessories

1. Mount equipment in accordance with the installation detail drawings as prepared by the Contractor and reviewed by the District. Mount equipment so that it is rigidly supported, level and plumb, and in such a manner as to provide accessibility; protection from damage; isolation from heat, shock, and vibration; and free from interference with other equipment, piping, and electrical work. Do not install consoles, cabinets, and panels until heavy construction work adjacent to computer and telemetry equipment has been completed to the extent that there shall be no damage or dust intrusion to the equipment.
2. Locate devices, including accessories, where they shall be accessible from grade, except as shown otherwise.
3. Mount local equipment in cabinets or existing panels as specified. Mount associated I/O terminals on a common panel or rack. Mounting panels and rack shall be baked enamel.
4. Coordinate the installation of the electrical service to components related to the system to ensure a compatible and functionally correct system. All accessories shall be coordinated and installation supervised by the Contractor.

5. Test the complete system after installation to ensure that all components are operating with the specified range and all interlocks are functioning properly.

D. Testing

1. The Contractor and Instrumentation Systems and Control Panel Supplier shall perform testing and start-up of the instrumentation and control equipment in accordance with General Provisions Section 01510, Testing, Training, and Facility Start-up and 17332, Instrumentation and Control System Testing and Start-up.

E. Maintenance and Repair Manuals

1. Maintenance manuals shall be prepared and submitted to the District for preliminary review in six copies. When the District is satisfied that these are complete and properly prepared, six final copies shall be submitted to the District.
2. The complete maintenance manual shall contain all the information included in the preliminary equipment submittal, the detailed installation submittal, programming instructions, and the additional information required herein, all bound in hard-cover binders and arranged for convenient use including tab sheets, all indexed and cross referenced, and all final as-built drawings.
3. Maintenance manuals shall contain:
 - a. calibration and maintenance instructions,
 - b. trouble-shooting instructions, and
 - c. instructions for ordering replacement parts.
4. At the time of submittal of the maintenance manuals, the Contractor shall provide as-built versions of all submittal drawings and equipment manufacturer shop drawings. The Contractor and Instrumentation Systems and Control Panel Supplier shall also provide electronic files for all "As-Built" shop drawings in AutoCAD format (latest version) with the maintenance manuals.

END OF SECTION

SECTION 17110: IDENTIFICATION TAGS

PART 1 - GENERAL

A. Description

This section includes requirements for materials and installation of identification tags for instrumentation and control systems.

B. Related Work Specified Elsewhere

1. General Electrical requirements: 16010
2. General Instrumentation Control Requirements: 17000

C. Submittals

Submit shop drawing in accordance with the General Provisions and Sections 16010 and 17000.

PART 2 - MATERIALS

A. Designations of Components

1. Metal Tags and Backplates

Style S1

Material: Stainless steel, type 316

Thickness: 0.040"

Size: 2³/₈" x 3/4" (± 0.1")

Holes: 2 each, diameter = 0.12" . See Figure 1 below, for location.



Figure 1 (not to scale)

Letter size: 3/16" high, 1/8" wide (no more than 12 characters in one line)

Characters shall be engraved in the center of the tag with a minimum depth of 0.009" or more and filled with Black enamel paint.

Manufacturer for S1: McMaster-Carr or equal

2. Backplate

Material: Stainless steel, type 316

Thickness: 0.040"

Size: **Style B1:** 8¹/₂" x 5¹/₂" (± 0.1")

Style B2: 8½" x 11" (± 0.1")

Style B3: To be cut to fit.

Holes: 2 each, diameter = 0.12" . See Figure 2, below, for location.



Figure 2 (not to scale)

3. Plastic Tags

a. Style L1

Material: Laminated Plastic with UV inhibitor
Thickness: 1/16"
Color: White plastic behind and Black on front.
Size: 2³/₈" x 3/4" (± 0.1")
Letter size: 3/16" high, 1/8" wide and 0.010" deep
(one line with 12 characters maximum)

b. Style L2

Material: Laminated Plastic with UV inhibitor
Thickness: 1/16"
Color: White plastic behind and Black on front.
Size: 2" x 3/8" (± 0.1")
Letter size: 5/32" high, 1/8" wide and 0.010" deep
(one line with 12 characters maximum)

c. Style L3 Plastic

Material: Laminated Plastic with UV inhibitor
Thickness: 1/16"
Color: White plastic behind and Black on front.
Size: 3" x 3/4" (± 0.1")
Holes: one each, diameter = 3/16" . See Figure 3, below, for location.

Manufacturer for L1, L2 & L3: Nu-Way (La Mirada, CA) or Dreiling Manufacturing (Pacoima, CA) or equal.



Figure 3 (not to scale)

4. Plastic Backplate

Material: Laminated Plastic with UV inhibitor

Thickness: 1/16"

Color: White plastic behind and Black on front.

Size: **Style B1:** 8½" x 5½" (± .0.1")

Style B2: 8½" x 11" (± .0.1")

Style B3: To be cut to fit.

Holes: 2 each, diameter = 3/16" . See Figure 4 below, for location.

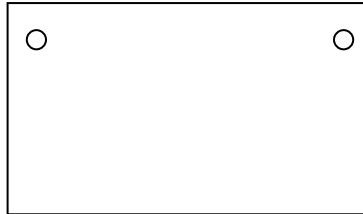

Figure 4 (not to scale)

5. Aluminum Foil Tags

Material: Aluminum

Thickness: 0.003"

Size: 1.375" x 0.437". Corners = 3/32" 1/8" serialization.

Color: #31 Dark Green Background with # 10 Aluminum Text.

Characters: 1/8". Variable number printed on each label.

Adhesive: 3M 467

Manufacturer: Lustre-Cal (Lodi, CA) or Express (La Jolla, CA) or equal.

PART 3 - EXECUTION

A. Adhesive

Use Silicone II from GE (General Electric)

B. SST Wire

Lead seal and 12" Monel wire from BRADY Signmark Division. Catalog number 23302.
Use the hand sealing press Catalog number 23300 for this wire.

Nylon Coated stranded stainless steel wire alloy 316 from BRADY Signmark Division.
Catalog number: 23310. Use Brass wire clamp – double ferrule design Catalog number
23312. Use clamping tool Catalog number 23311 for this wire.

END OF SECTION